

Made for Motion

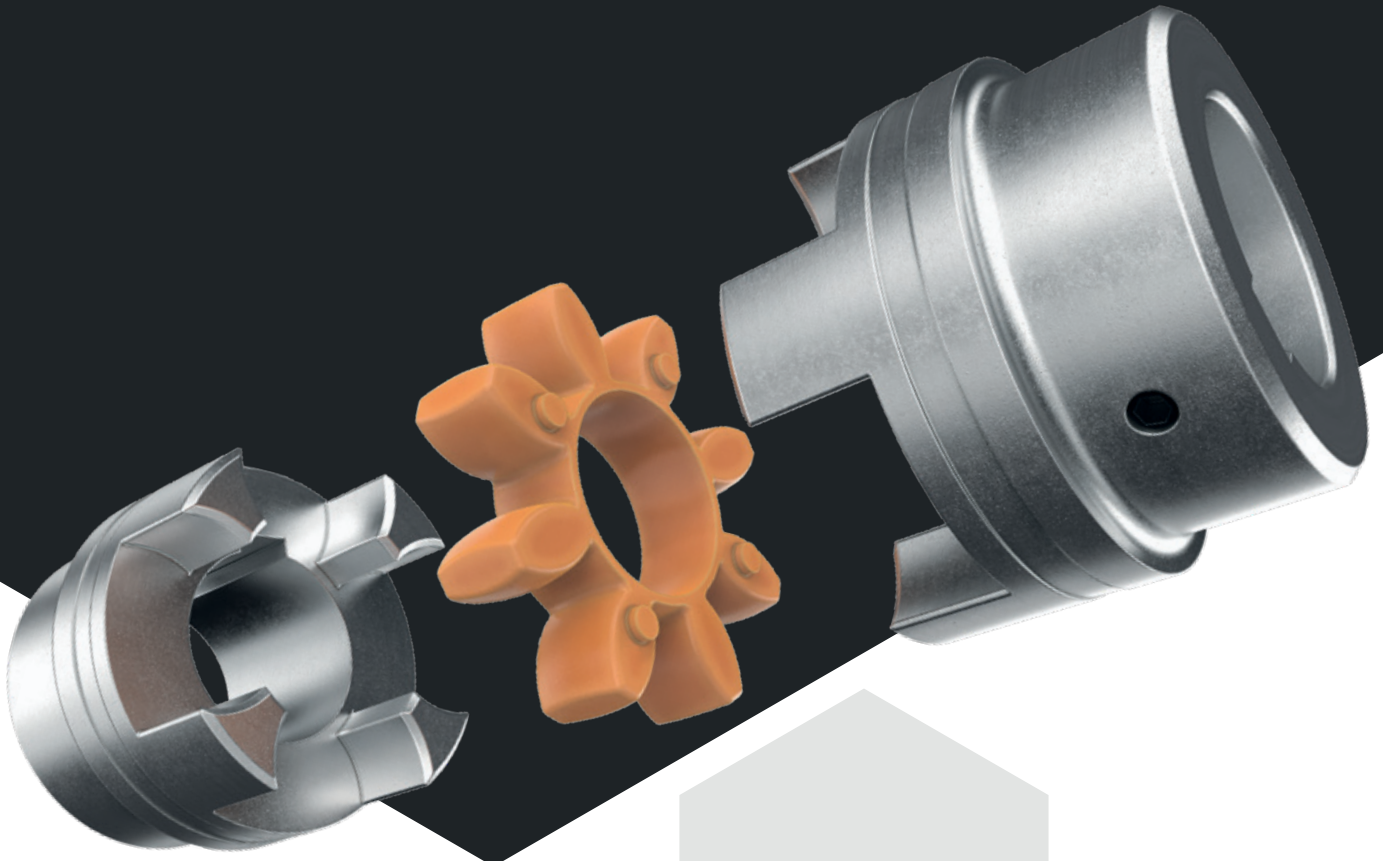

## Drive Technology

Couplings

Torque limiters

Clamping elements

Torque measuring systems

2025/26

[www.ktr.com](http://www.ktr.com)

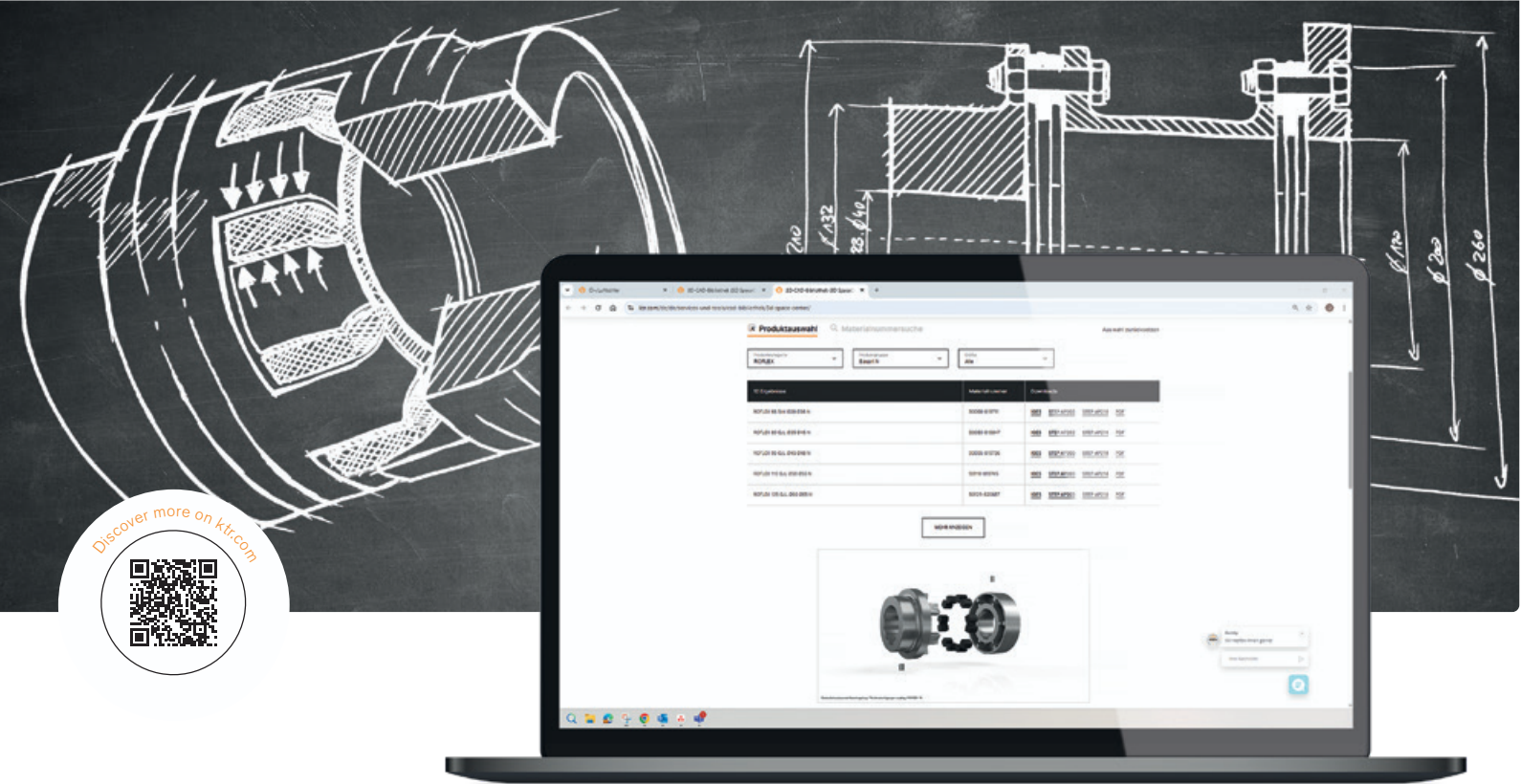

## Quickly to your goal: The new 3D-CAD library is live

With the new 3D-CAD library, KTR makes access to technical drawings easier than ever before. Access is directly via the KTR website - without external platforms or additional registration. The state-of-the-art user interface is intuitive to use allowing to find the requested CAD data with just a few clicks.

Thanks to the integrated material numbers retrieval and high-performance filter functions, products can be found even more specifically. The selection is additionally facilitated by relevant supplemental information that is directly displayed in the CAD selection.

The CAD data is available in the common 3D formats STEP AP203, STEP AP214 and IGES. Besides, for selected data records 2D-PDF files are available - ideal for fast processing in designing.



## Responsibility needs transparency

### Together for sustainable transformation:

With our first sustainability report we provide insight into our strategic orientation and specific measures in three central fields of action:

In environmental and climate protection we are systematically working on reducing emissions, using resources efficiently and making our products more environmentally friendly. We live our social responsibility by a safe, fair and supportive working environment, long-term training initiatives and local commitment. In responsible corporate management we create clear structures, review our supply chains while consistently focusing our processes on transparency and integrity.

Scan the QR code to learn more about how we not only document sustainability, but anchor in our daily actions.

Please contact our Corporate Responsibility team at: [responsibility@ktr.com](mailto:responsibility@ktr.com)



# Our product innovations

Discover more on [ktr.com](http://ktr.com)



## Highly flexible flange coupling with progressive torsion spring stiffness



### VAROLASTIC®

- Progressive torsion spring stiffness
- Highly flexible elastomers (rollers) for up to +120 °C
- Short and solid design
- Versatile applications (construction and agricultural machinery, gensets, ...)
- Version with and without failure protection
- Numerous adaptations to SAE possible

(see page 234)

Stiffness characteristic (progressive)

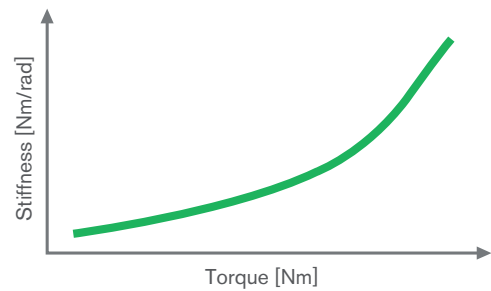

Discover more on [ktr.com](http://ktr.com)



## Steel laminae coupling for wind turbines



**EXCLUSIVE  
ON KTR.COM**

### RADEX®-N Multi Disc

- Further development of the proven RADEX®-N wind power coupling
- Newly developed slipping system
- Significantly more and longer slipping processing possible
- Higher efficiency and durability with sophisticated wind power applications

## Those who value KTR as a manufacturer will love us as a partner.

KTR provides the mechanical and plant engineering with an extensive portfolio of high-quality drive and hydraulic components as well as braking and cooling systems. We are pleased to be at your service during the designing stage and develop tailor-made solutions for you. Perfectly organized logistics, global presence via 24 subsidiary companies and more than 90 distribution partners along with an international network consisting of 7 production sites are the prerequisite for quick delivery. When it comes to service we ensure short distances along with competent personal support.





**„Innovation and tradition  
are the key components of  
our product portfolio and  
KTR's corporate culture.“**

Nicola Warning, CEO of KTR

# Wherever motion is essential, we have the right answer.

## Drive technology and shaft connections



Mechanical components are and will remain essential in drive technology. The industry's demands on components grow continuously: energy efficiency, power density, ease of servicing and electrification. Our portfolio includes couplings and torque limiters, clamping sets and universal joints as well as torque measuring shafts.

## Brake Systems



Our hydraulic and electromechanical brake systems are globally used in various industries. Customer preference and parameters of the application decide upon the selection of the right brake.

## Hydraulic components



For almost 50 years we have provided the industry with a continuously growing range of hydraulic components from our in-house development and manufacturing: accurate selection, high-quality processing, quick availability.

## Cooling systems



As a customised product or standard solution, multimedum or oil-air cooler, for mobile machines or stationary hydraulics, optionally available as a marine or ATEX version, powerful and efficient.

# PART OF EXCELLENCE



**Wind power**



**Construction machinery**



**Agricultural engineering**



**Pumps and compressors**



**Automation**



**Machine tools**



**Hydraulics**



**General drive technology**



**Marine**



**Gensets**

# SUMMARY OF PRODUCTS/INDUSTRIES

WIND POWER	Gearless wind turbines	Wind turbines	Local power grids	CONSTRUCTION AND AGRICULTURAL MACHINERY	Excavators	Road rollers	Crushers	Combine harvesters	Tank spreaders	PUMPS AND COMPRESSORS	Compressors	Pumps	Cooling towers	INDOOR MATERIALS HANDLING	Conveying and storage	Food processing machinery	Packaging machinery

## COUPLINGS

### Flexible jaw and pin & bush couplings

ROTEX®		■			■	■	■	■	■		■	■	■		■	■	■	■
ROFLEX®											■	■	■					
POLY-NORM®											■	■	■					
POLY-NORM®-M								■										
REVOLEX® KX-D								■				■						

### Gear couplings

BoWex®							■					■				■	■	■
GEARex®															■	■	■	■

### Backlash-free servo couplings

ROTEX® GS	■	■	■				■								■	■	■	■
ROTEX® GS P / HP																		
TOOLFLEX®		■													■	■	■	■
RADEX®-NC															■	■	■	■

### Steel laminae couplings

RADEX®-N		■									■	■	■		■	■	■	■
RIGIFLEX®-N											■	■						

### Highly flexible shaft couplings

EVOLASTIC®					■	■	■	■	■		■	■	■					
BoWex® HEW Compact											■	■						

### Flange couplings for I. C.-engines

Pump mounting flanges					■	■	■	■							■			
BoWex® FLE-PA / FLE-PAC					■	■	■	■							■			
MONOLASTIC®					■	■	■	■							■			
BoWex-ELASTIC®					■	■	■	■			■	■						
SINULASTIC®					■	■	■	■			■	■						
VAROLASTIC®					■	■	■	■			■	■						

### Magnetic couplings

MINEX®-S											■	■			■	■	■	■
----------	--	--	--	--	--	--	--	--	--	--	---	---	--	--	---	---	---	---

### TORQUE LIMITERS

RUFLEX®						■	■	■							■	■	■	■
KTR SI/KTR SI Compact								■							■	■	■	■
SYNTEX®/SYNTEX®-NC															■	■	■	■

### CLAMPING SETS

CLAMPEX®		■			■	■	■	■	■		■	■	■		■	■	■	■
----------	--	---	--	--	---	---	---	---	---	--	---	---	---	--	---	---	---	---

### TORQUE MEASURING TECHNOLOGY

DATAFLEX®		■	■		■	■	■	■			■	■			■	■	■	■
MONITEX® BT		■			■	■	■	■	■		■	■			■	■	■	■

Automation	MACHINE TOOLS	Positioning axes	Main spindle drives	Robotic drives	HYDRAULICS	Power pack production	Plastics processing industry	GENERAL DRIVE TECHNOLOGY	Industrial gears	Planetary gears	Extruders	Metering machines	Steel mills	Linear technology	SHIPBUILDING / MARINE	Cargo ships	Cruises	Yachts	Workboats	GENSETS	Emergency power generators	Product pages from page
																						30
																						61
																						65
																						72
																						73
																						86
																						102
																						120
																						136
																						148
																						162
																						174
																						184
																						194
																						206
																						211
																						212
																						218
																						220
																						228
																						234
																						242
																						258
																						264
																						276
																						294
																						344
																						354

# SUMMARY OF PRODUCTS / SPECIFICATIONS

Max. torque [Nm]	Max. circumferential speed [m/s]	Max. bore diameter [mm]	Torsionally stiff	Flexible	Highly torsionally flexible	Backlash-free	Maintenance-free	Fail-safe	Shear type	Compact dimensions	Double-cardanic	Single-cardanic	High
------------------	----------------------------------	-------------------------	-------------------	----------	-----------------------------	---------------	------------------	-----------	------------	--------------------	-----------------	-----------------	------

COUPLINGS													
Flexible jaw and pin & bush couplings													
ROTEX®	35,000	60	200		■			■	■		■	■	■
ROFLEX®	5,000	35	120		■			■	■		■	■	■
POLY-NORM®	67,000	35	280		■			■	■		■	■	■
POLY-NORM®-M	5,500,000	35	900		■			■	■		■	■	■
REVOLEX® KX-D	1,350,000	60	650		■		■	■	■		■	■	■
Gear couplings													
BoWex®	2,500	30	125	■				■	■		■	■	■
GEARex®	2,750,000	-	520	■				■	■		■	■	■
Backlash-free servo couplings													
ROTEX® GS	5,850	80	110		■		■	■	■		■	■	■
TOOLFLEX®	600	40	65	■			■	■	■		■	■	■
RADEX®-NC	300	35	55	■			■	■	■		■	■	■
Steel laminae couplings													
RADEX®-N	280,000	65	330	■			■	■	■		■	■	■
RIGIFLEX®-N	280,000	100	400	■			■	■	■		■	■	■
Highly flexible shaft couplings													
EVOLASTIC®	5,600	60	140			■	■	■	■		■	■	■
BoWex® HEW Compact	8,400		125			■	■	■	■		■	■	■
Flange couplings for I. C.-engines													
BoWex® FLE-PA / FLE-PAC	6,600	50	125	■				■	■		■	■	■
MONOLASTIC®	1,850	50	60		■			■	■		■	■	■
BoWex-ELASTIC®	70,000		275			■	■	■	■		■	■	■
SINULASTIC®	25,000		240			■	■	■	■		■	■	■
VAROLASTIC®	6,000		110			■	■	■	■		■	■	■
Magnetic couplings													
MINEX®-S	1,000		90		■			■	■		■	■	■
TORQUE LIMITERS													
RUFLEX®	12,000		140								■	■	■
KTR-SI	8,200		100								■	■	■
KTR-SI FRE	60,000		200								■	■	■
KTR-SI FRA	2,600		80								■	■	■
SYNTEX®	400		50				■	■	■		■	■	■
SYNTEX®-NC	550		60				■	■	■		■	■	■
KTR-SI Compact	3,100		80				■	■	■		■	■	■
CLAMPING SETS													
CLAMPEX®	7,394,000		1,000				■	■	■		■	■	■
TORQUE MEASURING TECHNOLOGY													
DATAFLEX®	500,000	-	-	■	■		■	■	■		■	■	■
MONITEX® BT	800			■	■		■	■	■		■	■	■

For legend of certificate refer to flapper on the cover



High power density	Axial plug-in	All-steel	Contactless	Friction coupling	Ratchet coupling	Self-centering	Not self-centering	<b>MARINE</b>						Coupling selection acc. to DIN 740 part II (page 14 et seqq.)	Coupling selection based on operating factors (page 18 et seqq.)	Coupling selection acc. to DIN 740 part II with spec. factors (page 22 et seqq.)	Product pages from page
								ATEX	GOST R/GOST TR	Bureau Veritas	American Bureau of Shipping	DNV/GL	ClassNK				

■								■	■	■	■	■	■				30
■								■	■					■			61
■								■	■					■			65
■															■		72
■								■	■	■	■	■			■		73
■								■	■	■	■	■	■				86
	■							■		■	■	■	■		■		102
■								■								■	120
■	■															■	148
								■								■	162
		■						■	■	■	■	■			■		174
		■						■	■	■	■	■			■		184
■															■		194
■								■	■	■		■			■		206
■									■	■					■		212
■									■	■					■		218
■								■	■	■		■			■		220
■															■		228
■															■		234
			■					■									242
		■		■													258
		■			■												264
		■				■											265
		■															266
																	276
																	286
		■															289
							■	■				■					294
■			■														344
■			■														354

# INDEX OF SUBJECTS

<b>A</b>		<b>L</b>	
Mounting flanges	P.215	Stock programme of finish bores	P.88, 127
Drop-out center design couplings	P.71, 78, 140, 160, 288	Laminae couplings	P.164 et seqq., 172 et seqq.
External clamping sets	P.78, 326 et seqq.	<b>M</b>	
<b>B</b>		Magnetic couplings	P.246 et seqq.,
Basic programme	P.64, 69, 75, 78	Metal bellow-type couplings	P.150 et seqq.
Coatings	P.74	Miniature couplings	P.128, 152 et seqq.
Curved-tooth gear couplings®	P.82-115	Miniature clamping sets	P.310 et seqq., 312 et seqq., 314 et seqq.,
Shear pin couplings	P.79, 115	322 et seqq.	
<b>D</b>		Modularly structured coupling	P.26-81
Permanent-magnetic couplings	P.246 et seqq.	<b>N</b>	
Distance couplings	P.71, 79, 108, 144 et seqq., 162, 170	Flexible couplings	P.26-81
Double-cardanic shaft couplings	P.79, 102 et seqq., 142 et seqq., 162, 166 et seqq., 172 et seqq.	Cam couplings	P.120 et seqq.
Torsionally flexible couplings	P.26-81, 120 et seqq.	<b>P</b>	
Torque limiters	P.58, 260 et seqq., 264-298	Precision couplings	P.134 et seqq.
Torque measuring shafts	P.352-361	Precision joints	P.338 et seqq.
Torsionally stiff couplings	P.150 et seqq., 164 et seqq., 172 et seqq.	<b>R</b>	
Speed measuring shafts	P.348-364	Ratchet couplings	P.272-298
Torque measuring technology	P.348-364	Torque limiters	P.266-271
Fail-safe shaft couplings/ellenkupplungen	P.26-81	<b>S</b>	
<b>E</b>		Shifting hubs	P.79, 94
Stainless steel couplings	P.172 et seqq., 183, 250 et seqq.,	Servo couplings	P.120 et seqq., 150 et seqq., 164 et seqq.
Flexible couplings	P.26-81	Servo laminae couplings	P.164 et seqq.
Flexible elements	P.32-34	Safety couplings	P.79
Elastomer couplings	P.26-81, 120 et seqq.	Spacer couplings	P.71, 79, 108, 144 et seqq., 162 et seqq., 170 et seqq.
Use in potentially explosive atmospheres	P.38-49, 63, 64, 95, 120 et seqq., 164 et seqq., 246 et seqq.,	Clamping ring hubs	P.78, 132 et seqq., 168
<b>F</b>		Clamping sets	P.57, 78-79, 300 et seqq.
Flange couplings	P.212-244	Safety couplings with retaining elements	P.272-298
Flexible couplings	P.26-81	Backlash-free couplings	P.120 et seqq., 150 et seqq., 164 et seqq., 172 et seqq.
Idle rotation couplings	P.264-298	Steel laminae couplings	P.164 et seqq., 172 et seqq.
<b>G</b>		Steel shaft couplings	P.78, 172 et seqq.
All-steel gear couplings	P.102 et seqq.	Rigid shaft couplings	P.334 et seqq.
Rubber elements	P.26-81	Stars	P.26-81
<b>H</b>		<b>T</b>	
Hermetic sealing	P.246 et seqq.	Taper clamping sleeves	P.68
Highly flexible couplings	P.140, 144, 160, 170, 210, 224	<b>U</b>	
<b>I</b>		Overload couplings/Overload systems	P.79, 260 et seqq.,
Internal clamping sets	P.308 et seqq.	Universal clamping sets	P.300 et seqq.
<b>K</b>		<b>W</b>	
Jaw couplings	P.26-71, 120 et seqq.	Shaft-hub-connections	P.57, 78, 79, 300 et seqq.
Clamping hubs	P.129 et seqq., 154 et seqq., 166 et seqq.	Precision joints	P.338 et seqq.
Taper clamping ring hubs	P.78, 132 et seqq.	Shaft couplings	P.26-79, 102 et seqq., 120 et seqq., 150 et seqq., 164 et seqq., 172 et seqq., 334 et seqq.
Corrosion protection	P.74	<b>Z</b>	
Ball ratcheting couplings	P.272-298	Spiders	P.32-34, 121 et seqq.
Coupling starts	P.32-34	Spider hardness	P.32-34, 121 et seqq.
Nylon stars	P.32-34	Gear couplings	P.82 et seqq.
		Intermediate shafts	P.79, 144 et seqq., 162 et seqq., 170 et seqq.

# Product Overview

## Couplings

Flexible jaw and pin & bush couplings	26
Gear couplings	82
Backlash-free servo couplings	116
Steel laminae couplings	170
Highly flexible shaft couplings	190
Flange couplings	208
Magnetic couplings	238

## Torque limiters

Torque limiters	258
Overload systems	264
Backlash-free overload systems	276

## Clamping elements and precision joints

Clamping sets	294
Clamping nut	328
Precision joints	330

## Torque measuring technology

Torque measuring shafts	344
-------------------------	-----



# COUPLING SELECTION ACCORDING TO DIN 740 PART II

## Coupling types

### Flexible jaw couplings

ROTEX® Flexible coupling (see page 30)



- flexible
- maintenance-free
- fail-safe
- compact dimensions
- axial plug-in

ROFLEX® Flexible coupling (see page 61)



- flexible
- maintenance-free
- fail-safe
- axial plug-in

POLY-NORM® Flexible coupling (see page 65)



- flexible
- maintenance-free
- fail-safe
- compact dimensions
- axial plug-in

### Gear couplings

BoWex® Torsionally stiff curved-tooth gear coupling\* (see page 86)



- torsionally stiff
- maintenance-free
- non fail-safe type
- compact dimensions
- single-cardanic or double-cardanic
- axial plug-in

### Highly flexible shaft couplings

EVOLASTIC® Highly flexible coupling (see page 194)



- highly flexible
- maintenance-free
- fail-safe
- axial plug-in
- backlash-free

BoWex® HEW Compact Highly flexible shaft coupling (see page 206)



- highly flexible
- maintenance-free
- fail-safe
- compact dimensions
- Single- and double-cardanic
- axial plug-in
- backlash-free

### Flange couplings for I. C.-engines

BoWex® FLE-PA/-PAC Torsionally stiff flange coupling (see page 212/214)



- torsionally stiff
- maintenance-free
- non fail-safe type
- compact dimensions
- single-cardanic
- axial plug-in

MONOLASTIC® One-piece, flexible flange coupling (see page 218)



- flexible
- maintenance-free
- non fail-safe type
- compact dimensions
- single-cardanic
- axial plug-in

BoWex-ELASTIC® Highly flexible flange coupling (see page 220)



- flexible to highly flexible
- maintenance-free
- non fail-safe type
- compact dimensions
- single-cardanic
- axial plug-in

SINULASTIC® Highly flexible flange coupling (see page 228)

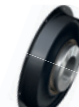

- highly flexible
- maintenance-free
- non fail-safe type
- compact dimensions
- axial plug-in

VAROLASTIC® Highly flexible flange coupling (see page 234)



- highly flexible
- progressive torsion spring stiffness
- maintenance-free
- non fail-safe / fail-safe
- compact dimensions
- axial plug-in

# COUPLING SELECTION ACCORDING TO DIN 740 PART II

## Terminology of coupling selection

Description	Symbol	Definition resp. explanation
Rated torque of coupling [Nm]	$T_{KN}$	Torque that can be continuously transmitted over the entire permissible speed range
Maximum torque of coupling [Nm]	$T_{Kmax}$	Torque that can be transmitted as dynamic load $\geq 10^5$ times respectively $5 \cdot 10^4$ as vibratory load over the entire service life of the coupling
Vibratory torque of coupling [Nm]	$T_{KW}$	Torque amplitude of the permissible periodical torque fluctuation with a frequency of 10 Hz and a basic load of $T_{KN}$ respectively dynamic load up to $T_{KN}$ .
Damping power of coupling [W]	$P_{KW}$	Permissible damping power with an ambient temperature of +30 °C
Rated torque of machine [Nm]	$T_N$	Stationary rated torque on the coupling
Rated torque of driving side [Nm]	$T_{AN}$	Rated torque of machine, calculated on the basis of rated power and rated speed
Rated torque of load side [Nm]	$T_{LN}$	Maximum figure of the load torque calculated on the basis of power and speed
Peak torque of machine [Nm]	$T_S$	Peak torque on the coupling
Peak torque of driving side [Nm]	$T_{AS}$	Peak torque with torque shock on driving side, e. g. tilting moment of the electric motor
Peak torque of load side [Nm]	$T_{LS}$	Peak torque with torque shock on load side, e. g. braking
Vibratory torque of machine [Nm]	$T_W$	Amplitude of the vibratory torque effective on the coupling

Description	Symbol	Definition resp. explanation
Damping power of machine [W]	$P_W$	Damping power which is effective on the coupling due to the load generated by the vibratory torque
Engine power [kW]	$P$	Rated power of drive
Speed [rpm]	$n$	Rated speed of the motor
Rotational inertia coefficient of driving side	$M_A$	Factor considering the mass distribution with shocks and vibrations generated on the driving or load side
Rotational inertia coefficient of load side	$M_L$	
Mass moment of inertia of driving side [kgm <sup>2</sup> ]	$J_A$	Total of moments of inertia existing on the driving or load side referring to the coupling speed
Mass moment of inertia of load side [kgm <sup>2</sup> ]	$J_L$	
Mass moment of inertia of coupling [kgm <sup>2</sup> ]	$J_{KA}$	Mass mom. of inertia of the coupl. half on drive side
	$J_{KL}$	Mass mom. of inertia of the coupl. half on load side
Start-up factor	$S_Z$	Factor considering the additional load caused by the starting frequency per hour
Shock factor on driving side	$S_A$	Factor considering the shocks arising depending on the application (e. g. starting shocks)
Shock factor on load side	$S_L$	
Temperature factor	$S_t$	Factor considering the lower loading capacity resp. larger deformation of an elastomer part under load particularly in case of increased temperatures
Operating factor	$S_B$	Factor considering the different demands on the coupling dependent on the application
Screw tightening torque [Nm]	$T_A$	Tightening torque of screw

Temperature factor $S_t$										
	-40 °C/+30 °C	≤ +40 °C	≤ +50 °C	≤ +60 °C	≤ +70 °C	≤ +80 °C	≤ +90 °C	≤ +100 °C	≤ +110 °C	≤ +120 °C
<b>ROTEX®</b>										
T-PUR®	1.00	1.00	1.20	1.30	1.45	1.60	1.80	2.10	2.50	3.00
PUR	1.00	1.00	1.30	1.40	1.55	1.80	2.20	-	-	-
PA	1.00	1.00	1.00	1.00	1.2	1.40	1.60	-	-	-
<b>POLY-NORM®/ROFLEX®</b>										
NBR 78 Shore A	1.00	1.20	1.30	1.40	1.60	1.80	-	-	-	-
<b>POLY</b>										
NBR (cuboid)	1.00	1.20	1.30	1.40	1.60	1.80	-	-	-	-
<b>EVOLASTIC®</b>										
NR	1.00	1.00	1.00	1.25	1.40	1.60	-	-	-	-
<b>BoWex®</b>										
PA 6.6	1.00	1.00	1.00	1.00	1.20	1.40	1.60	1.80	-	-
PA-CF	1.00	1.00	1.00	1.00	1.10	1.20	1.40	1.60	1.90	2.20
BoWex® HEW Compact	1.00	1.00	1.00	1.00	1.10	1.40	1.70	-	-	-
<b>BoWex® FLE-PA/-PAC</b>										
PA 6 GF	1.00	1.00	1.00	1.00	1.00	1.00	1.20	1.40	1.60	1.80
PA-CF	1.00	1.00	1.00	1.00	1.10	1.20	1.40	1.60	1.90	2.20
<b>MONOLASTIC®</b>										
NR	1.00	1.00	1.00	1.00	1.10	1.40	1.70	-	-	-
<b>BoWex-ELASTIC®</b>										
NR	1.00	1.00	1.00	1.00	1.10	1.40	1.70	-	-	-
<b>SINULASTIC®</b>										
NR	1.00	1.00	1.00	1.25	1.40	1.60	-	-	-	-
EPDM <sup>1)</sup>	1.00	1.00	1.00	1.20	1.20	1.20	1.40	1.60	1.60	2.00
SI	1.00	1.00	1.00	1.30	1.30	1.30	1.30	1.30	1.40	1.60
<b>VAROLASTIC®</b>										
EPDM <sup>1)</sup>	1.00	1.00	1.00	1.20	1.20	1.20	1.40	1.60	1.60	2.00

For the selection with PEEK spider a temperature factor is not necessary. For temperature factors for PA spiders see page 32.  
With temperatures below -40 °C consult with KTR.

<sup>1)</sup> For -30°C/+30°C

Start-up factor $S_Z$				
<b>ROTEX®, POLY-NORM®, BoWex®, BoWex® HEW Compact, EVOLASTIC®</b>				
Start-up frequency per hour	< 100	< 200	< 400	< 800
$S_Z$	1.0	1.2	1.4	1.6
<b>BoWex-ELASTIC®, SINULASTIC®, VAROLASTIC®</b>				
Start-up frequency per hour	< 10	< 60	< 120	> 120
$S_Z$	1.0	1.5	2.0	On request

Shock factor $S_A/S_L$	
<b>ROTEX®, POLY-NORM®, BoWex®, BoWex® HEW Compact, BoWex-ELASTIC®, EVOLASTIC®, SINULASTIC®, VAROLASTIC®</b>	$S_A/S_L$
Moderate shocks	1.5
Medium shocks	1.8
Heavy shocks	2.5

Operating factor $S_B$	
<b>Hydrostatic drives for BoWex® FLE-PA, FLE-PAC, MONOLASTIC®</b>	
Applications	$S_B$
Wheel loaders	1.6
Compact loaders	1.6
Hydraulic excavators	1.4
Mobile cranes	1.6
Graders	1.5
Vibration rollers	1.4
Forklift trucks	1.6
Concrete mixer trucks	1.3
Concrete pumps	1.4
Asphalt finishers	1.4
Concrete cutters	1.4
Road milling machines	1.4

## Permissible load on feather keyway of the coupling hubs

The shaft-hub-connection needs to be verified by the customer.

Permissible surface pressure according to DIN 6892 (method C)			
Cast iron (GJL)	225 N/mm <sup>2</sup>	Sintered steel	180 N/mm <sup>2</sup>
Nodular iron (GJS)	225 N/mm <sup>2</sup>	Aluminium diecast (Al-D)	110 N/mm <sup>2</sup>
steel	250 N/mm <sup>2</sup>	Aluminium wrought products (Al-H)	200 N/mm <sup>2</sup>
Polyamide	30 N/mm <sup>2</sup> (up to +40 °C)	For other steel materials pperm.	$0.9 \cdot R_e (R_{p0.2})$

# COUPLING SELECTION ACCORDING TO DIN 740 PART II

## Coupling selection

The coupling selection is based on DIN 740 part 2. The coupling has to be dimensioned in that the permissible coupling load is not exceeded during any operating condition. For this purpose the actual loads must be compared to the permissible coupling parameters. The specified torques  $T_{KN}/T_{K\ max}$  refer to the couplings. The shaft-hub-connection needs to be verified by the customer.

### 1. Drives without periodical torsional vibrations

For example centrifugal pumps, fans, screw compressors, etc. The coupling selection is based on reviewing the rated torque  $T_{KN}$  and the maximum torque  $T_{K\ max}$ .

#### 1.1 Loading generated by rated torque

Considering the ambient temperature the permissible rated torque  $T_{KN}$  of the coupling must at least equal the rated torque of the machine  $T_N$ .

$$T_N [Nm] = 9550 \cdot \frac{P [kW]}{n [rpm]}$$

$$T_{KN} \geq T_N \cdot S_t$$

#### 1.2 Loading generated by torque shocks

The permissible maximum torque of the coupling  $T_{K\ max}$  must at least equal the total of the peak torque  $T_S$  and rated torque of the machine  $T_N$  taking into account the shock frequency  $S_Z$  and the ambient temperature  $S_t$ . This applies in case if the rated torque of the machine  $T_N$  is superimposed by a shock process. Knowing the mass distribution, direction and kind of shock it is possible to calculate the peak torque  $T_S$ . For drives with A. C. motors and big masses on the load side we recommend to run a calculation of the peak starting torque by our simulation program.

$$T_{K\ max} \geq T_S \cdot S_Z \cdot S_t + T_N \cdot S_t$$

$$\text{Shock on drive side} \\ T_S = T_{AS} \cdot M_A \cdot S_A$$

$$\text{Shock on load side} \\ T_S = T_{LS} \cdot M_L \cdot S_L$$

$$M_A = \frac{J_L}{(J_A + J_L)}$$

$$M_L = \frac{J_A}{(J_A + J_L)}$$

### 2. Drives with periodical torsional vibrations

For drives subject to torsional vibrations, e. g. diesel engines, piston compressors, piston pumps, generators etc. it is necessary to perform a torsional vibration calculation for a selection ensuring safe operation. If requested, we will perform the torsional vibration calculation and the coupling selection in our company. For the necessary details refer to KTR standard 20004.

#### 2.1 Loading generated by rated torque

Considering the ambient temperature the permissible rated torque  $T_{KN}$  of the coupling must at least equal the rated torque of the machine  $T_N$ .

$$T_{KN} \geq T_N \cdot S_t$$

#### 2.2 Passing through the resonance range

Considering the temperature the peak torque  $T_S$  arising when passing through the resonance range must not exceed the maximum torque  $T_{K\ max}$  of the coupling.

$$T_{K\ max} \geq T_S \cdot S_t$$

#### 2.3 Loading generated by vibratory torque shocks

Considering the ambient temperature the permissible vibratory torque  $T_{KW}$  of the coupling must not be exceeded by the biggest periodical vibratory torque  $T_W$  with operating speed. With higher operating frequencies  $f > 10$  Hz the heat generated by damping in the elastomer is considered as damping power  $P_W$ . The permissible damping power  $P_{KW}$  of the coupling depends on the ambient temperature and must not be exceeded by the damping power generated.

$$T_{KW} \geq T_W \cdot S_t$$

$$P_{KW} \geq P_W$$

With torsionally stiff couplings the damping power can be ignored.

## Coupling selection of BoWex® FLE-PA, MONOLASTIC® and EVOLASTIC®

### 1. Loading generated by rated torque

For drives with small mass moments of inertia on the load side (hydrostatic drives) the selection can be simplified using operating factors.

$$T_{KN} \geq T_N \cdot S_B \cdot S_t$$

#### Please note:

For drives subject to torsional vibrations, e. g. diesel engines, piston compressors, piston pumps, generators etc. it is necessary to perform a torsional vibration calculation for a selection ensuring a safe operation. This applies in particular with large mass moments of inertia on the load side. If requested, we will perform the torsional vibration calculation and the coupling selection in our company.

# COUPLING SELECTION ACCORDING TO DIN 740 PART II

## Example of calculation

Requested: Axial plug-in coupling damping vibrations → ROTEX®  
 Applications: Connection of IEC standard motor and screw compressor  
 → Coupling selection following page 16, item 1: Drives without periodical torsional vibrations

### Given: Details of driving side

A. C. motor: Size 315 L →  $S_A = 1.8$  (see page 15)  
 Motor power:  $P = 160$  kW  
 Speed:  $n = 1485$  rpm  
 Moment of inertia of driving side:  $J_{Motor} = 2.9$  kgm<sup>2</sup>  
 Starting frequency: 6 times per hour →  $S_Z = 1.0$  (see page 15)  
 Ambient temperature: +70 °C →  $S_t = 1.45$  using T-PUR® (see page 15)  
 Peak torque (starting torque)  $T_{AS} = 2 \cdot T_{AN}$

### Given: Details of load side

Screw compressor:  
 Rated torque of load side:  $T_{LN} = 930$  Nm  
 Moment of inertia of load side:  $J_{Compressor} = 6.8$  kgm<sup>2</sup>

### Calculation

#### 1.1 Loading generated by rated torque

- Rated torque of drive  $T_{AN}$ 

$$T_{AN} = 9550 \cdot \frac{P [\text{kW}]}{n [\text{rpm}]} \rightarrow 9550 \cdot \frac{160 \text{ kW}}{1485 \text{ rpm}} = \underline{1029 \text{ Nm}}$$
- Rated torque of load side  $T_{LN}$ 

$$T_{KN} \geq T_{LN} \cdot S_t \rightarrow 930 \text{ Nm} \cdot 1.45 = 1348.5 \text{ Nm} \rightarrow T_{KN} \geq \underline{1348.5 \text{ Nm}}$$
- Coupling selection
 

ROTEX® size 90 - spider 92 Shore A with:	Mass moments of inertia of page 59
$T_{KN} = 2400$ Nm	$J_{KA} = 0.0673$ kgm <sup>2</sup>
$T_{K \max} = 4800$ Nm	$J_{KL} = 0.0673$ kgm <sup>2</sup>

#### 1.2 Loading generated by torque shocks

- Shock on driving side without load torque being superimposed

$$T_{K \max} \geq T_S \cdot S_Z \cdot S_t + T_N \cdot S_t \rightarrow T_N = 0$$

Shock on drive side  $T_S = T_{AS} \cdot M_A \cdot S_A$

$$M_A = \frac{J_L}{(J_A + J_L)} \rightarrow \frac{6.8673 \text{ kgm}^2}{2.9673 \text{ kgm}^2 + 6.8673 \text{ kgm}^2} \rightarrow M_A = \underline{0.7}$$

$$J_A = J_{Motor} + J_{KA} \rightarrow 2.9 \text{ kgm}^2 + 0.0673 \text{ kgm}^2 \rightarrow J_A = \underline{2.9673 \text{ kgm}^2}$$

$$J_L = J_{Compressor} + J_{KL} \rightarrow 6.8 \text{ kgm}^2 + 0.0673 \text{ kgm}^2 \rightarrow J_L = \underline{6.8673 \text{ kgm}^2}$$

Start-up torque  $T_{AS} = 2 \cdot T_{AN} \rightarrow 2 \cdot 1029 \text{ Nm} = \underline{2058 \text{ Nm}}$

$$\rightarrow \text{Shock on drive side } T_S = 2058 \cdot 0.7 \cdot 1.8 = \underline{2593.1 \text{ Nm}}$$

$$\rightarrow T_{K \max} \geq 2593.1 \text{ Nm} \cdot 1 \cdot 1.45 = \underline{3760 \text{ Nm}}$$

$T_{K \max}$  with 4800 Nm  $\geq$  3760 Nm ✓

### Result

The coupling is sufficiently dimensioned.

### Please note:

The shaft-hub-connection must be separately verified by the customer!

# COUPLING SELECTION BASED ON OPERATING FACTORS

## Coupling types

### Laminae couplings

RADEX®-N



Steel laminae coupling (see page 176)

- Torsionally stiff
- Backlash-free
- Maintenance-free
- Compact dimensions
- Single-cardanic or double-cardanic
- All-steel

RIGIFLEX®-N



Steel laminae coupling (see page 185)

- Torsionally stiff
- Backlash-free
- Maintenance-free
- Double-cardanic
- All-steel
- Coupling in accordance with API 610, API 671 optionally

### Pin & bush couplings

REVOLEX® KX-D



Flexible pin & bush coupling (see page 73)

- Flexible
- Maintenance-free
- Fail-safe
- Compact dimensions
- Axial plug-in

### Gear couplings

GEARex®



All-steel gear coupling (see page 102)

- Torsionally stiff
- Fail-safe
- Compact dimensions
- Double-cardanic
- High power density
- All-steel

### Flexible couplings

POLY-NORM®-M



Flexible coupling (see page 72)

- Flexible
- Maintenance-free
- Fail-safe
- Compact dimensions
- Axial plug-in

## Terminology of coupling selection

Description	Symbol	Definition resp. explanation
Rated torque of coupling [Nm]	$T_{KN}$	Torque that can be continuously transmitted over the entire permissible speed range
Maximum torque of coupling [Nm]	$T_{Kmax}$	Torque that can be transmitted as dynamic load $\geq 10^5$ times respectively $5 \cdot 10^4$ as vibratory load over the entire service life of the coupling
Vibratory torque of coupling [Nm]	$T_{KW}$	Torque amplitude of the permissible periodical torque fluctuation with a frequency of 10 Hz and a basic load of $T_{KN}$ respectively dynamic load up to $T_{KN}$ .
Rated torque of machine [Nm]	$T_N$	Stationary rated torque on the coupling
Peak torque of machine [Nm]	$T_S$	Peak torque on the coupling

Description	Symbol	Definition resp. explanation
Engine power [kW]	P	Rated power of drive
Speed [rpm]	n	Rated speed of the motor
Start-up factor	$S_Z$	Factor considering the additional load caused by the starting frequency per hour
Direction factor	$S_R$	Considers the torsional direction
Temperature factor	$S_t$	Factor considering the lower loading capacity particularly in case of increased temperatures
Operating factor	$S_B$	Factor considering the different demands on the coupling dependent on the application

# COUPLING SELECTION BASED ON OPERATING FACTORS

## Factors

Temperature factor $S_t$								
	-30 °C/ +30 °C	≤ +40 °C	≤ +60 °C	≤ +80 °C	≤ +150 °C	≤ +200 °C	≤ +230 °C	≤ +270 °C
REVOLEX® KX-D / POLY-NORM®-M	1.0	1.2	1.4	1.8	–	–	–	–
GEARex®	1.0	1.0	1.0	1.0	–	–	–	–
RADEX®-N, RIGIFLEX®-N, RIGIFLEX®-HP	1.0	1.0	1.0	1.0	1.0	1.10	1.25	1.43

Start-up factor $S_z$				Direction factor $S_R$	
Start-up frequency per hour	< 10	< 25	< 50	Same torsional direction	1.0
$S_z$	1.0	1.2	1.4	Alternating torsional direction	1.7

Operating factor $S_B$			
Application		Application	
<b>Construction machinery</b>		<b>Mixers</b>	
Manoeuvre hoists	1.50 - 2.00	Constant density	1.75 - 2.25
Swing gears	1.50 - 2.00	Variable density	2.00 - 2.50
Miscellaneous winches	1.50 - 2.00	<b>Grinders</b>	
Filters, cable winches	1.75 - 2.25	Centrifugal mills	1.75 - 2.00
Multi-bucket excavators	1.75 - 2.25	Beater mills	1.75 - 2.00
Running gears (caterpillar)	1.75 - 2.25	Autogenous mills	1.75 - 2.00
Impellers	1.75 - 2.25	Hammer and ball mills	2.00 - 2.50
Cutter drives	2.00 - 2.50	<b>Food industry</b>	
Elevators	1.50 - 2.00	Sugarcane harvesters	1.25 - 1.50
<b>Conveyor systems</b>		Sugar-beet harvesters	1.25 - 1.50
Bucket elevators	1.50 - 2.00	Sugar-beet washing	1.25 - 1.50
Elevators	1.75 - 2.25	Kneading machines	1.75 - 2.00
Hauling winches	1.50 - 2.00	Sugarcane breakers	1.75 - 2.00
Apron conveyors	1.25 - 1.75	Sugarcane mills	1.75 - 2.00
Rubber belt conveyors (bulk)	1.25 - 1.75	<b>Oil industry</b>	
Boom plate bucket conveyors	1.25 - 1.75	Filter presses for paraffin	1.50 - 2.00
Rotary conveyors	1.50 - 1.75	Rotary furnaces	1.75 - 2.00
Steel plate conveyors	1.50 - 1.75	<b>Paper machines</b>	
Worm conveyors	1.25 - 1.50	Couch rolls	1.75 - 2.25
Steel belt conveyors	1.75 - 2.00	Calanders	1.75 - 2.25
Conveyors	1.75 - 2.00	Wet presses	1.75 - 2.25
Rubber belt conveyors (bulk)	1.75 - 2.00	<b>Pumps</b>	
Inclined lifts	1.75 - 2.00	Radial pumps	1.25 - 1.75
Shaking slides	2.00 - 2.25	Centrifugal pumps (light liquid)	1.50 - 2.00
<b>Generators</b>		Centrifugal pumps (viscous liquid)	2.25 - 2.50
Frequency converters	1.75 - 2.00	Gear and vane pumps	1.50 - 1.75
Generators	1.50 - 2.00	Piston pumps, plunger pumps and press pumps	2.00 - 2.50
<b>Rubber &amp; nylon industry</b>		<b>Agitators</b>	
Rubber calanders and rolling mills	1.25 - 2.00	Light liquid	1.25 - 1.50
Mixers	1.25 - 2.00	Viscous liquid	1.50 - 1.75
Extruders	1.25 - 2.00	Liquid with constant density	1.25 - 1.50
<b>Lifters/cranes</b>		Liquid with variable density	1.50 - 2.00
Bridge cranes for steel industry	2.00 - 2.25	<b>Textile industry</b>	
Cranes (heavy load operation)	2.00 - 2.25	Winders	1.25 - 1.75
Running gears	1.75 - 2.25	Printing and dyeing machines	1.25 - 1.75
Lifting gears	1.75 - 2.25	Shredders	1.50 - 2.00
<b>Woodworking machinery</b>		<b>Fans, ventilators and blowers</b>	
Planing machines	1.50 - 1.75	Light-weight fans	1.25 - 1.75
Barking machines	1.75 - 2.00	Large fans	1.75 - 2.50
Saw frames	1.75 - 2.00	Centrifugal fans	1.25 - 1.50
<b>Compressors</b>		Industrial fans	1.25 - 1.50
Centrifugal compressors	1.50 - 2.00	Rotary blowers	1.25 - 1.75
Rotary compressors	1.50 - 2.00	Fans (axial/radial)	1.25 - 1.75
Turbo compressors	2.00 - 2.50	Fans for cooling towers	1.50 - 2.00
Piston compressors	2.50 - 3.00	<b>Wastewater treatment plants</b>	
<b>Metal industry</b>		Rakes	1.25 - 1.50
Wire pulls	1.25 - 1.50	Worm pumps	1.25 - 1.50
Winders	1.25 - 1.50	Concentrators	1.25 - 1.50
Winding drums	1.50 - 2.00	Mixers	1.25 - 1.75
Wire drawing machines	2.00 - 2.50	Aerators	1.75 - 2.00
Plate shears	2.00 - 2.50	<b>Machine tools</b>	
Block pushers	2.00 - 2.50	Scissors	1.50 - 2.00
Blooming and slabbing	2.00 - 2.50	Dressing rollers	1.50 - 2.00
De-scalers	2.00 - 2.50	Bending machines	1.50 - 2.00
Hot-rolling mills	2.00 - 2.50	Hole punching machines	1.75 - 2.50
Cold-rolling mills	2.00 - 2.50	Levelling machines	1.75 - 2.50
Billet shears	2.00 - 2.50	Hammers	1.75 - 2.50
Plugging machines	2.00 - 2.50	Presses	1.75 - 2.50
Continuous casting machines	2.00 - 2.50	Forging presses	1.75 - 2.50
Shifting devices	2.00 - 2.50	<b>Other</b>	
Application	2.00 - 2.50	Equipment for transport of persons	2.00 - 2.50
Roller tables (heavy-weight)	2.00 - 2.50	Rock crushers	2.50 - 3.00
		Rolling mill drives	2.00 - 2.50

# COUPLING SELECTION BASED ON OPERATING FACTORS

## Coupling selection

The coupling selection is based on operating factors. The coupling must be dimensioned in that the permissible coupling load is not exceeded during any operating condition. For this purpose the actual loads must be compared to the permissible coupling parameters. The shaft-hub-connection needs to be verified by the customer.

### 1. Drives without periodical torsional vibrations

For example centrifugal pumps, fans, screw compressors, etc. The coupling selection is based on reviewing the rated torque  $T_{KN}$  and the maximum torque  $T_{K\ max}$ .

#### 1.1 Loading generated by rated torque

Considering the operating factor, the ambient temperature and the torsional direction, the permissible rated torque  $T_{KN}$  of the coupling must at least equal the rated torque of the machine  $T_N$ .

$$T_N [Nm] = 9550 \cdot \frac{P [kW]}{n [rpm]}$$

$$T_{KN} \geq T_N \cdot S_B \cdot S_t \cdot S_R$$

#### 1.2 Loading generated by torque shocks

Taking into account all relevant factors, the permissible maximum torque of the coupling  $T_{K\ max}$  must at least equal the total of the peak torque  $T_S$  and rated torque of the machine  $T_N$ . This applies if the rated torque of the machine  $T_N$  is superimposed by a shock process. For drives with A. C. motors and big masses on the load side we recommend to run a calculation of the peak starting torque by our simulation program.

$$T_{K\ max} \geq (T_N + T_S) \cdot S_Z \cdot S_t \cdot S_R$$

### 2. Drives with periodical torsional vibrations

For drives subject to torsional vibrations, e. g. diesel engines, piston compressors, piston pumps, generators etc. it is necessary to perform a torsional vibration calculation for a selection ensuring a safe operation. If requested, we will perform the torsional vibration calculation and the coupling selection in our company. For the necessary details refer to KTR standard 20004.

# COUPLING SELECTION BASED ON OPERATING FACTORS

## Example of calculation

Requested: Double-cardanic steel laminae coupling for bridging a shaft distance dimension → RADEX®-N

Applications: Connection of IEC standard motor and radial pump

→ Coupling selection following page 20, item 1: Drives without periodical torsional vibrations

### Given: Details of driving side

A. C. motor: Size 315 L  
 Motor power:  $P = 200 \text{ kW}$   
 Speed:  $n = 1500 \text{ rpm}$   
 Starting frequency: 6 times per hour →  $S_Z = 1.0$  (see page 19)  
 Ambient temperature:  $+65 \text{ °C}$  →  $S_t = 1.0$  (see page 19)  
 Peak torque (starting torque)  $T_{AS} = 2 \cdot T_{AN}$   
 Diameter of motor shaft: 80 mm

### Given: Details of load side

Radial pump →  $S_B = 1.5$  (see page 19)  
 Rated torque of load side:  $T_{LN} = 930 \text{ Nm}$   
 Diameter of pump shaft: 75 mm  
 Distance dimension of motor shaft - pump shaft (DBSE) = 250 mm  
 Direction of torque: same →  $S_R = 1.0$  (see page 19)

## Calculation

### 1.1 Loading generated by rated torque

- Rated torque of drive  $T_{AN}$

$$T_{AN} = 9550 \cdot \frac{P [\text{kW}]}{n [\text{rpm}]} \rightarrow 9550 \cdot \frac{200 \text{ kW}}{1500 \text{ rpm}} = \underline{1273 \text{ Nm}}$$

- Loading generated by rated torque

$$T_{KN} \geq T_{AN} \cdot S_B \cdot S_t \cdot S_R \rightarrow 1273 \text{ Nm} \cdot 1.5 \cdot 1 \cdot 1 = 1909.5 \text{ Nm} \rightarrow T_{KN} \geq \underline{1909.5 \text{ Nm}}$$

### 1.2 Loading generated by torque shocks

- Shock on driving side without load torque being superimposed

$$T_{K \max} \geq (T_N + T_S) \cdot S_Z \cdot S_t \cdot S_R \rightarrow T_N = 0$$

$$\rightarrow \text{Start-up torque } T_{AS} = 2 \cdot T_{AN} \rightarrow 2 \cdot 930 \text{ Nm} = \underline{1860 \text{ Nm}}$$

$$\rightarrow T_{K \max} \geq 1860 \text{ Nm} \cdot 1 \cdot 1 \cdot 1 = \underline{1860 \text{ Nm}}$$

- Coupling selection

$$T_{KN} = 2400 \text{ Nm}$$

$$T_{K \max} = 4800 \text{ Nm}$$

## Result

The coupling is sufficiently dimensioned.

### Please note:

The shaft-hub-connection must be separately verified by the customer!

# COUPLING SELECTION ACCORDING TO DIN 740 PART II WITH SPECIFIC FACTORS

## Coupling types

### Backlash-free servo couplings

#### ROTEX® GS



Backlash-free, flexible jaw coupling (see page 120)

- Backlash-free and flexible
- Maintenance-free
- Fail-safe
- Compact dimensions, high power density
- Single-cardanic or double-cardanic
- Axial plug-in
- High speeds

#### TOOLFLEX®



Backlash-free, torsionally stiff metal bellow-type coupling (see page 148)

- Backlash-free and torsionally stiff
- Maintenance-free
- Shear type
- Compact dimensions
- Double-cardanic
- Axial plug-in (as an option)
- All-metal coupling

#### RADEX®-NC



Backlash-free, torsionally stiff servo laminae coupling (see page 162)

- Backlash-free and torsionally stiff
- Maintenance-free
- Compact dimensions
- Single-cardanic or double-cardanic
- All-metal coupling

#### ROTEX® GS HP



Backlash-free high-speed coupling (see page 136)

- Backlash-free and flexible
- Maintenance-free
- Compact dimensions
- Axial plug-in
- Severely high speeds

## Terminology of coupling selection

Description	Symbol	Definition resp. explanation
Rated torque of coupling [Nm]	$T_{KN}$	Torque which can be continuously transmitted over the entire permissible speed range, taking into account the factors
Maximum torque of coupling [Nm]	$T_{K \max}$	Torque which can be transmitted over the entire service life of the coupling as dynamic load $\geq 10^5$ or vibratory load $5 \cdot 10^4$ taking into account the factors
Rated torque of machine [Nm]	$T_N$	Stationary rated torque on the coupling
Rated torque of driving side [Nm]	$T_{AN}$	Constantly occurring driving torque as per the data indicated by the motor manufacturer
Peak torque [Nm]	$T_S$	Peak torque on the coupling
Peak torque of driving side [Nm]	$T_{AS}$	Peak torque with torque shock on driving side, e. g. starting torque of the servo motor as per the data specified by the motor manufacturer
Peak torque of load side [Nm]	$T_{LS}$	Peak torque with torque shock on load side, e. g. braking
Screw tightening torque [Nm]	$T_A$	Tightening torque of screw
Friction torque [Nm]	$T_R$	Torque that can be transmitted through the frictionally engaged shaft-hub-connection

Description	Symbol	Definition resp. explanation
Rotational inertia coefficient of driving side	$M_A$	Factor considering the mass distribution with shocks and vibrations generated on the driving or load side
Rotational inertia coefficient of load side	$M_L$	
Mass moment of inertia of driving side [kgm <sup>2</sup> ]	$J_A$	Total of moments of inertia existing on the driving or load side referring to the coupling speed
Mass moment of inertia of load side [kgm <sup>2</sup> ]	$J_L$	
Mass moment of inertia of coupling [kgm <sup>2</sup> ]	$J_{KA}$	Mass mom. of inertia of the coupl. half on drive side
	$J_{KL}$	Mass mom. of inertia of the coupl. half on load side
Mass moment of inertia [kgm <sup>2</sup> ]	$J_{Mot}/J_{Sp}/J_{HS}$	Mass moment of inertia of the motor/mass moment of inertia of the spindle/mass moment of inertia of the main spindle
Temperature factor	$S_t$	Factor considering the lower loading capacity or larger deformation of an elastomer part under load particularly with increased temperatures
Operating factor	$S_B$	Factor considering the different demands on the coupling dependent on the application

# COUPLING SELECTION ACCORDING TO DIN 740 PART II WITH SPECIFIC FACTORS

## Factors

Temperature factor $S_t$														
	-50 °C	-40 °C	-30 °C	-20 °C/ +30 °C	≤ +40 °C	≤ +50 °C	≤ +60 °C	≤ +70 °C	≤ +80 °C	≤ +90 °C	≤ +100 °C	≤ +110 °C	≤ +120 °C	≤ +200 °C
<b>ROTEX® GS</b>														
Polyurethane 80 ShA-GS	1.0	1.0	1.0	1.0	1.2	1.3	1.4	1.55	1.8	-	-	-	-	-
Polyurethane 92 ShA-GS	-	1.0	1.0	1.0	1.2	1.3	1.4	1.55	1.8	2.2	-	-	-	-
Polyurethane 98 ShA-GS	-	-	1.0	1.0	1.2	1.3	1.4	1.55	1.8	2.2	-	-	-	-
Polyurethane 57 ShD-GS	-	-	1.0	1.0	1.2	1.3	1.4	1.55	1.8	2.2	-	-	-	-
Polyurethane 64 ShD-GS	-	-	-	1.0	1.2	1.3	1.4	1.55	1.8	2.2	3.0	3.0	-	-
Polyurethane 72 ShD-GS	-	-	-	1.0	1.2	1.3	1.4	1.55	1.8	2.2	3.0	3.0	-	-
PUR 52 ShD-S-GS	1.0	1.0	1.0	1.0	1.0	1.0	1.0	1.2	1.3	1.4	1.55	1.8	2.2	-
Hytrel 64 ShD-H-GS	1.0	1.0	1.0	1.0	1.2	1.3	1.4	1.5	1.6	1.8	2.0	2.3	2.8	-
Hytrel 72 ShD-H-GS	1.0	1.0	1.0	1.0	1.2	1.3	1.4	1.5	1.6	1.8	2.0	2.3	2.8	-
<b>TOOLFLEX®</b>														
Size 5 to 12	-	-	1.0	1.0	1.0	1.0	1.0	1.0	1.0	1.0	1.0	-	-	-
Size 16 to 65	-	-	1.0	1.0	1.0	1.0	1.0	1.0	1.0	1.0	1.0	1.0	1.0	1.1
<b>RADEX-NC®</b>														
EK and DK	-	-	1.0	1.0	1.0	1.0	1.0	1.0	1.0	1.0	1.0	1.0	1.0	1.1
<b>ROTEX® GS HP</b>														
Polyurethane 98 ShA-GS	-	-	1.0	1.0	1.2	1.3	1.4	1.55	1.8	2.2	-	-	-	-

Operating factor $S_B$	
<b>ROTEX® GS*</b>	
<b>Backlash-free drives</b>	
Main spindle drive of machine tools	
Moderate shocks	Grinders, small milling machines/drills
Medium shocks	Milling machines/drills with interrupted cut
Heavy shocks	Milling machines etc.
Positioning drives	
<b>Ball screw drive/toothed belt drive</b>	
Gearbox	$i \leq 5$
	$i > 5 - \leq 7$
	$i > 7$
<b>Servo-hydraulic drives</b>	
With pulsating load <sup>1)</sup>	
With vibratory load <sup>2)</sup>	
<b>TOOLFLEX®, RADEX-NC</b>	
Uniform motion	
Irregular motion	
Shock motion	
For drives on machine tools (servo motors) values from 1.5 - 2.0 must be applied.	
<b>ROTEX® GS HP</b>	
Main spindle drive	
<b>Start-up factor <math>S_Z</math></b>	
Starting frequency per minute	
< 20	1.0
< 60	1.2
< 120	1.4
< 180	1.6
< 240	1.8
> 240	2.0

\* When using the spider 64 ShD-GS or 72 ShD-GS a minimum factor of 4 or steel hubs have to be used.

<sup>1)</sup> With pulsating load the use of aluminium is permissible.

<sup>2)</sup> With vibratory load make use of steel hubs.

Shaft encoder drives: Subject to the low torques to be transmitted the coupling size for shaft encoder drives is selected according to the shaft diameters to be connected.

## Coupling selection

The coupling selection of the backlash-free servo couplings is based on DIN 740 part 2, but with specific factors. The coupling has to be dimensioned in that the permissible coupling load is not exceeded during any operating condition. For this purpose the actual loads must be compared to the permissible coupling parameters. The shaft-hub-connection needs to be verified by the customer.

The size of the coupling must be selected such that the following conditions are met.

### 1. Backlash-free drives

$$T_{KN} \geq T_N \cdot S_t \cdot S_B$$

and

$$T_{KN} \geq T_S \cdot S_t \cdot S_B$$

$$\text{In case of load torque: } T_{KN} \geq T_S \cdot S_t \cdot S_B + T_N \cdot S_t$$

Considering the ambient temperature and the operating factor, the permissible rated torque  $T_{KN}$  of the coupling must at least equal the rated torque of the machine  $T_N$ .

Considering the ambient temperature and the operating factor, the permissible rated torque  $T_{KN}$  of the coupling must at least equal the peak torque arising.

The following applies for the peak torque  $T_S$ :

$$T_S = T_{AS} \cdot M_A \cdot S_Z \quad \longrightarrow \quad M_A = \frac{J_L}{(J_A + J_L)}$$

### 2. Servo-hydraulic drives

$$T_{KN} \geq T_{AS} \cdot S_t \cdot S_B$$

Considering the ambient temperature and the operating factor, the permissible rated torque  $T_{KN}$  of the coupling must at least equal the peak torque of the driving side  $T_{AS}$ .

$S_t \cdot S_B$  with use of aluminium at least 1.5.

### Please note:

For general applications (not backlash-free applications) observe coupling selection according to DIN 740 part 2 (page 14 et seqq.).

# COUPLING SELECTION ACCORDING TO DIN 740 PART II WITH SPECIFIC FACTORS

## Example of calculation for positioning drives

Requested: Backlash-free coupling damping vibrations

→ ROTEX® GS

Applications: Connecting servo motor and ball screw drive for backlash-free positioning

→ Coupling selection following page 23, item 1: Backlash-free drives

### Given: Details of driving side

Servo motor

Rated torque  $T_{AN}$ : 43 Nm  
 Max. driving torque  $T_{AS}$ : 144 Nm  
 Moment of inertia  $J_{Mot}$ : 0.0108 kgm<sup>2</sup>  
 Diameter of motor shaft: 32 k6 without feather keyway

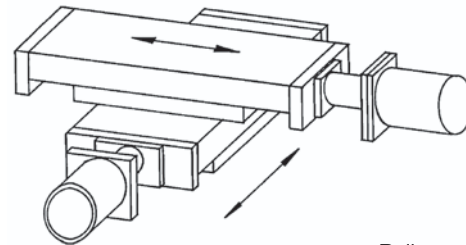

Ball screw

Ambient temperature: +40 °C

→  $S_t = 1.2$  (see page 23)

Starts per minute: 15

→  $S_z = 1.0$  (see page 23)

### Given: Details of machine on driven side

Ball spindle  $J_{Sp}$ : 0.0038 kgm<sup>2</sup>  
 Spindle pitch  $s$ : 10 mm  
 Diameter of spindle shaft: 30 k6 without feather keyway  
 Mass of slide + workpiece  $m_{Sl}$ : 1030 kg  
 No load torque available

Required: High torsional stiffness

→  $S_B = 4$  (see page 23)

### Calculation

#### 1. Backlash-free drives

- Loading by rated torque (pre-selection)

$$T_{KN} \geq T_{AN} \cdot S_t \cdot S_B \quad \rightarrow 43 \text{ Nm} \cdot 1.2 \cdot 4 \quad \rightarrow T_{KN} \geq 206.4 \text{ Nm}$$

- Coupling selection (pre-selection)

ROTEX® GS 38

Spider 98 Shore A with clamping ring hubs 6.0 light:

Mass moments of inertia of page 138

$T_{KN} = 325 \text{ Nm}$

$J_{KA} = 0.000517 \text{ kgm}^2$

$T_{K \max} = 650 \text{ Nm}$

$J_{KL} = 0.000517 \text{ kgm}^2$

- Load by maximum driving torque, not including load torque

$$T_{KN} \geq T_S \cdot S_t \cdot S_B$$

$$\text{Shock on drive side} \quad T_S = T_{AS} \cdot M_A \cdot S_z \quad \rightarrow = 144 \text{ Nm} \cdot 0.379 \cdot 1.0 \quad \rightarrow T_S = 54.58 \text{ Nm}$$

$$M_A = \frac{J_L}{(J_A + J_L)} \quad \rightarrow = \frac{0.006917 \text{ kgm}^2}{(0.011317 \text{ kgm}^2 + 0.006917 \text{ kgm}^2)} \quad \rightarrow M_A = 0.379$$

$$J_L = J_{Sp} + J_{Sl} + J_{KL} \quad \rightarrow 0.0038 \text{ kgm}^2 + 0.0026 \text{ kgm}^2 + 0.000517 \text{ kgm}^2 \quad \rightarrow J_L = 0.006917 \text{ kgm}^2$$

$$J_{Sl} = m_{Sl} \cdot \left( \frac{s}{2 \cdot \pi} \right)^2 \quad \rightarrow 1030 \text{ kg} \cdot \left( \frac{0.01}{2 \cdot \pi} \right)^2 \quad \rightarrow J_{Sl} = 0.0026 \text{ kgm}^2$$

$$J_A = J_{Mot} + J_{KA} \quad \rightarrow 0.0108 \text{ kgm}^2 + 0.000517 \text{ kgm}^2 \quad \rightarrow J_A = 0.011317 \text{ kgm}^2$$

$$\rightarrow T_{KN} \geq 54.58 \text{ Nm} \cdot 1.2 \cdot 4 \quad \rightarrow T_{KN} \geq 261.9 \text{ Nm}$$

$T_{KN}$  with 325 Nm  $\geq 261.9 \text{ Nm}$

- Review of shaft-hub-connection: Friction torque for clamping ring hubs type 6.0 light

The coupling has to be dimensioned in that the permissible friction torque is not exceeded during any operating condition.

$$T_R \geq T_{AS} \quad \text{values } T_R \text{ see page 132}$$

Friction torque of ROTEX® GS 38 clamping ring hub 6.0 light Ø30 H7/k6  $T_R = 656 \text{ Nm} > 144 \text{ Nm}$

### Result

The coupling is sufficiently dimensioned.

# COUPLING SELECTION ACCORDING TO DIN 740 PART II WITH SPECIFIC FACTORS

## Example of calculation for main spindle drives

Requested: Backlash-free, axial plug-in coupling for high speeds → ROTEX® GS  
 Applications: Connecting servo motor and main spindle in grinding machine  
 → Coupling selection following page 23, item 1: Backlash-free drives

### Given: Details of driving side

Servo motor

Max. continuous torque with machining  $T_{AN}$ : 130 Nm  
 Max. driving torque  $T_{AS}$ : 190 Nm  
 Max. speed: 6000 rpm  
 Moment of inertia  $J_{Mot}$ : 0.316 kgm<sup>2</sup>  
 Diameter of motor shaft: 38 k6 without feather keyway

Ambient temperature: +60 °C →  $S_t = 1.4$  (see page 23)  
 Starting factor  $S_Z$ : < 20 rpm →  $S_Z = 1.0$  (see page 23)

### Given: Details of machine on driven side

Moment of inertia of load side  $J_{HS}$ : 0.1094 kgm<sup>2</sup>  
 Diameter of main spindle shaft: 30 k6 without feather keyway  
 No load torque available

Required: Medium shocks →  $S_B = 2.4$  (see page 23)

### Calculation

#### 1. Backlash-free drives

● Loading by rated torque (machining torque)  $T_{KN} \geq T_{AN} \cdot S_t \cdot S_B \rightarrow 130 \text{ Nm} \cdot 1.4 \cdot 2.4 \rightarrow T_{KN} \geq 436.8 \text{ Nm}$

#### ● Coupling selection

ROTEX® GS 42

Spider 98 Shore A with clamping ring hubs 6.0 light:

Mass moments of inertia of page 138

$T_{KN} = 450 \text{ Nm}$

$J_{KA} = 0.001117 \text{ kgm}^2$

$T_{K \max} = 900 \text{ Nm}$

$J_{KL} = 0.001117 \text{ kgm}^2$

#### ● Loading by maximum driving torque, without load torque (acceleration of spindle)

$T_{KN} \geq T_S \cdot S_t \cdot S_B$

Shock on drive side  $T_S = T_{AS} \cdot M_A \cdot S_Z \rightarrow 190 \text{ Nm} \cdot 0.258 \cdot 1.0 \rightarrow T_S = 49.02 \text{ Nm}$

$M_A = \frac{J_L}{(J_A + J_L)} \rightarrow = \frac{0.110517 \text{ kgm}^2}{(0.317117 \text{ kgm}^2 + 0.110517 \text{ kgm}^2)} \rightarrow M_A = 0.258$

$J_L = J_{HS} + J_{KL} \rightarrow 0.1094 \text{ kgm}^2 + 0.001117 \text{ kgm}^2 \rightarrow J_L = 0.110517 \text{ kgm}^2$

$J_A = J_{Mot} + J_{KL} \rightarrow 0.316 \text{ kgm}^2 + 0.001117 \text{ kgm}^2 \rightarrow J_A = 0.317117 \text{ kgm}^2$

$T_{KN} \geq 49.02 \text{ Nm} \cdot 1.4 \cdot 2.4 \rightarrow T_{KN} \geq 164.7 \text{ Nm}$

$T_{KN}$  with 450 Nm  $\geq 164.7 \text{ Nm}$

#### ● Review of shaft-hub-connection: Friction torque for clamping ring hubs type 6.0 light

The coupling has to be dimensioned in that the permissible friction torque is not exceeded during any operating condition.

$T_R \geq T_{AS}$  values  $T_R$  see page 132

Friction torque of ROTEX® GS 42 clamping ring hub 6.0 light Ø30 H7/k6  $T_R = 752 \text{ Nm} > 190 \text{ Nm}$

### Result

The coupling is sufficiently dimensioned.

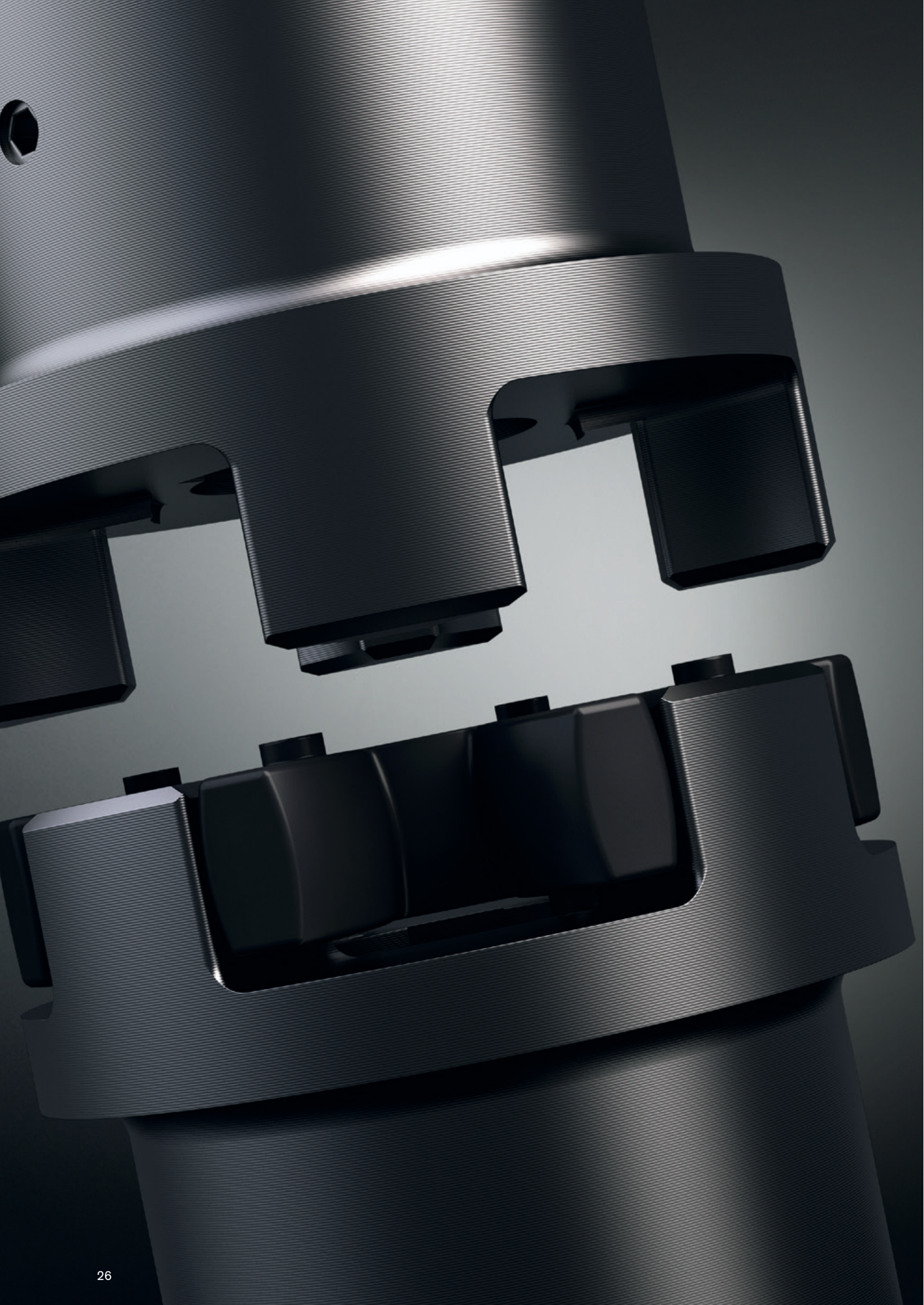

# Flexible jaw and pin & bush couplings

Types and operating description 28

<b>ROTEX®</b>	
Types of hubs	30
Speeds and displacements	31
Standard spiders	32
Special spiders	34
Selection of standard IEC motors	35
Cylindrical bores and inch bores	36
Spline bores and taper bores	37
Standard type, material aluminium + cast + sinter material	38
Standard type, material steel / stainless steel / DIN EN 10204 / marine / UL	40
Type with taper clamping sleeve	42
Type with clamping ring hubs	43
Type with clamping hubs	44
Type AFN, BFN flange programme	45
Type AH drop-out center design coupling	46
Type SH drop-out center design coupling with SPLIT hubs	47
Type CF, CFN, DF, DFN flange programme	48
Type ZS-DKM-SH double-cardanic shaft coupling	49
Type ZRS intermediate shaft programme	50
Type ZR intermediate shaft programme	51
Type BTAN, SBAN with brake drum, brake disk	52
Type AFN-SB drop-out center design coupling with brake disk	54
Type SD shifttable coupling shifttable at standstill	55
Type FNN for mounting of fan	56
Other types with clamping sets	57
Other types with torque limiters	58
Weights and mass moments of inertia	59

<b>ROFLEX®</b>	
Technical data	61
Selection of standard IEC motors	62
Type N	63
Type SH	64

<b>POLY-NORM®</b>	
Technical data	65
Selection of standard IEC motors	66
Type AR, two-part	67
Type AR for taper clamping sleeve	68
Type ADR, three-part	69
Type BTA, SBA with brake drum, brake disk	70
Type ADR-SB with brake disk for holding brake	
Type AZR, standard drop-out center design coupling	71

<b>POLY-NORM®-M</b>	
Type AFN, three-part	72

<b>REVOLEX®</b>	
Technical data	73
Type KX-D, material cast	74
Type KX-D, material steel	75
Type KX-D SB with brake disk	76
Type KX-D with KTR 650 clamping set	78
Technical data of pins	80
Assembly / disassembly / other types	81

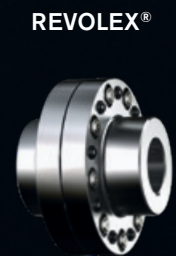
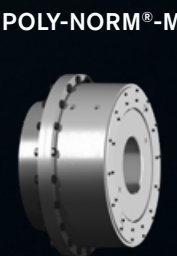
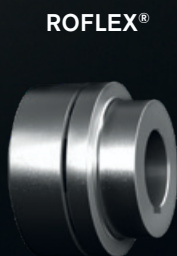

# FLEXIBLE JAW AND PIN & BUSH COUPLINGS

## TYPES AND OPERATING DESCRIPTION

### Properties of flexible jaw and pin & bush couplings

					
Product	ROTEX®	ROFLEX®	POLY-NORM®	POLY-NORM®-M	REVOLEX®
Type	Torsionally flexible jaw coupling				Torsionally flexible pin & bush coupling
<b>Features</b>					
Torsionally flexible	●	●	●	●	●
Damping vibrations	●	●	●	●	●
Maintenance-free	●	●	●	●	●
Axial plug-in	●	●	●		●
Shear type				●	
Fail-safe	●	●	●	●	●
Compensating for misalignment	●	●	●	●	●
<b>Types</b>					
Variant diversity	very high	medium	medium	medium	high
Special features	extensive basic programme available from stock while customised solutions can be realized	basic programme available from stock	basic programme available from stock	Basic programme available from stock, ideal for customised solutions, for applications with high performances	extensive programme, ideal for customised solutions, for applications with high performance ranges
Applications / core industries	manifold applications, applicable in all industries	pump industry, industrial gearboxes	pump industry, industrial gearboxes	heavy mechanical engineering, mills, conveyors, crushers, industrial gearboxes	industrial gearboxes, conveyor systems, industrial fans, cableways, agitators, generators, ...
surface	allover machining, very good dynamic properties	shell surface machined	shell surface machined	shell surface machined	allover machining, good dynamic properties
<b>Torque range <math>T_{KN}</math> [Nm]</b>					
Min.	1	65	40	100,000	4300
Max.	35,000	5,000	67,000	5,500,000	1,350,000
<b>Max. circumferential speed <math>v</math> [m/s]</b>					
Cast EN-GJL (dynamic balancing)	35	35	35		35
Steel + cast EN-GJS (dynamic balancing)	60			35	60
<b>Hub materials available</b>					
Steel (semi-finished product) » customised solutions available	●			●	●
Cast iron (GJL) » subject to mould	●	● <sup>1)</sup>	●		●
Nodular iron (GJS) » subject to mould	●		○	●	○
Aluminium wrought products (Al-H) » customised solutions available	●				
Aluminium diecast (Al-D)	●				
Stainless steel	●				
Corrosion-protected types	●		○	●	●
<b>Spiders / elastomers</b>					
Material	T-PUR®, PA, PEEK, Hytrel, ...	T-PUR® (size 68) NBR (from size 80)	NBR (up to size 180) T-PUR® (from size 200)	NBR, NBR electrically insulating	NR, NBR, NBR electrically insulating
Degree of hardness	flexible to torsionally stiff	flexible	flexible	flexible	flexible
Temperature range in °C, min. / max. (standard)	-40 / +120	-30 / +80	-30 / +80	-30 / +80	-30 / +80
Temperature range in °C, min. / max. (special)	-40 / +250	-30 / +80	-30 / +80	-30 / +80	-50 / +80

● ≈ Standard

○ ≈ On request

<sup>1)</sup> Size 68 made of sintered steel

# FLEXIBLE JAW AND PIN & BUSH COUPLINGS

## TYPES AND OPERATING DESCRIPTION

### Product finder of jaw and pin & bush couplings

					
Product	ROTEX®	ROFLEX®	POLY-NORM®	POLY-NORM®-M	REVOLEX®
Type	Torsionally flexible jaw coupling				Torsionally flexible pin & bush coupling
<b>Geometries</b>					
Design	compact	short	short	short	short
Mass moment of inertia	low	medium	medium	high	medium
Shaft distance dimension	low / average	low	low	low	low
<b>Types (extract)</b>					
Elastomers can be radially disassembled » without displacing driving/driven side	AFN, AH, SH, ZR, DF, DFN, CF-H	SH	ADR, ADR-SB	AFN, A	Standard
Intermediate shaft types » bridging larger shaft distances	ZR, ZWN	-	-	-	customised
Standard spacers 100 mm to 250 mm	ZS-DKM-SH	-	AZR	-	customised
shaft-to-shaft connection	Standard	N	Standard	Standard	Standard
flange-to-shaft connection	CF, CFN	-	-	A	customised
Flange-to-flange connection » particularly short mounting length	DF, DNF	-	-	-	customised
Double-cardanic » compensating for big displacements, lower restoring forces	ZS-DKM-H, ZR, ZWN	-	-	-	-
<b>Certifications / type examinations</b>					
ATEX 	●	●	●	○	●
UL-listed 	●				
DNV/GL 	●			○	●
ABS 	●			○	○
Bureau Veritas 	●			○	○
LR 	●				○
RS CLASS 	○				○
CCS 	○				○
ClassNK 	●				○
Korean Register 	●				○

● ≈ Standard  
○ ≈ On request

### Types of hubs

Since ROTEX® is used on many different applications and mounting conditions, this coupling system is available with various hub types. These types mainly differ in that they provide either positive or frictionally engaged (backlash-free) connections, but mounting situations like, for example, gear shafts with integrated transmission cams or similar applications are covered, too. Applications are considered.

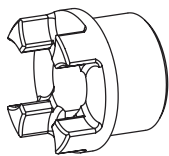

#### Type 1.0 hub with feather keyway and setscrew

Positive-locking power transmission, permissible torque depending on the permissible surface pressure. Not suitable for backlash-free power transmission with heavily reversing operation.

Type 1.1 hub without feather keyway, with setscrew

Non-positive torque transmission for crimping connections and adhesive bonds. (No ATEX approval)

Type 1.3 hub with spline bore (see page 37)

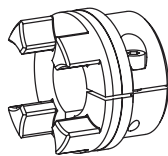

#### Type 2.3 clamping hub with spline bore

For splines see page 37. Positive-locking power transmission. The friction fit avoids resp. reduces reverse backlash.

Type 2.0 clamping hub single slot without feather keyway

Frictionally engaged, backlash-free shaft-hub-connection. Transmittable torques depending on bore diameter (see page 44). (For ATEX category 3 only)

Type 2.1 clamping hub single slot with feather keyway

Positive-locking power transmission with additional friction fit. The friction fit avoids resp. reduces reverse backlash. Surface pressure of the keyway connection is reduced.

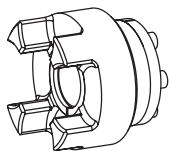

#### Type 4.2 hub for CLAMPEX® clamping set KTR 250

Frictionally engaged, backlash-free shaft-hub-connection for transmitting average torques.

Type 4.1 for CLAMPEX® clamping set KTR 200  
Type 4.3 for CLAMPEX® clamping set KTR 400

Frictionally engaged, backlash-free shaft-hub-connection for the transmission of high torques.

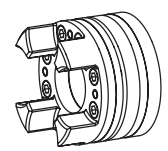

#### Type 6.0 clamping ring hub (see ROTEX® GS series)

Integrated frictionally engaged shaft-hub-connection for the transmission of higher torques. Screwing on elastomer side. For details about torque and dimensions see page 43. Suitable for high speeds.

Type 6.5 clamping ring hub (see ROTEX® GS series)

Design like 6.0, except for clamping screws externally. For instance for radial disassembly of intermediate pipe (special design).

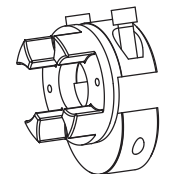

#### Type 7.6 clamping hub type DH with feather keyway for double-cardanic connection

Positive-locking power transmission with additional friction fit for radial assembly of coupling. The friction fit avoids resp. reduces reverse backlash. Surface pressure of the keyway connection is reduced.

Type 7.5 clamping hub type DH without feather keyway for double-cardanic connection

Frictionally engaged, backlash-free shaft-hub-connection for radial assembly of coupling. Transmittable torques depending on bore diameter. (For ATEX category 3 only)

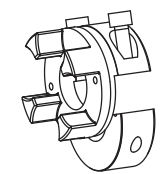

#### Type 7.9 clamping hub type H with feather keyway

Positive-locking power transmission with additional friction fit for radial assembly of coupling. The friction fit avoids resp. reduces reverse backlash. Surface pressure of the keyway connection is reduced.

Type 7.8 clamping hub type H without feather keyway

Frictionally engaged, backlash-free shaft-hub-connection for radial assembly of coupling. Transmittable torques depending on bore diameter. (For ATEX category 3 only)

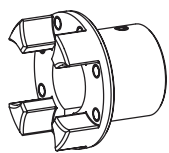

#### FNN hub

Coupling hub to be connected to an attachment such as brake drum, brake disk and fan.

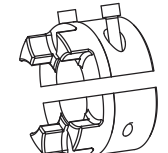

#### Type 7.1 SPLIT hub with feather keyway

Split hub made of cast iron. Positive-locking power transmission with additional friction fit. The friction fit avoids resp. reduces reverse backlash. Surface pressure of the keyway connection is reduced.

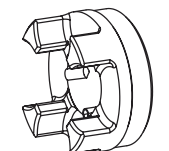

#### TB1 hub/TB2 hub

Coupling hub for taper clamping sleeves TB1 screwed on cam side. TB2 screwed externally.

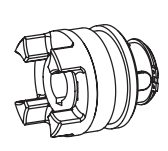

#### SD hub shifting hub

Coupling hub for separating resp. switching on the driving/driven machine with downtime of the machine. Can be combined with slip ring and shiftable linkage.

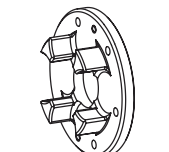

#### Driving flange type 3b

Driving flange to connect to customer's component. For dimensions see page 48.

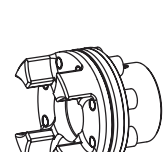

#### Type 3Na and 4N Driving flange with flange type K

For type AFN and BFN. With type AFN the spider can be replaced when installed without having to disassemble the driving and driven side.

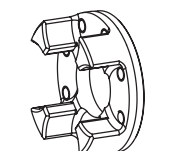

#### Driving flange type 3Na

Driving flange to connect to customer's component. For dimensions see page 48.

## Speeds

Maximum speeds of hub versions/types																		
ROTEX® size	Maximum speed [rpm]													Maximum speed [rpm] depending on outside Ø of brake drum/disk				
	1.0 / 1.1 / 1.3			2.0 / 2.1 / 2.3 / 7.5 / 7.6 / 7.8 / 7.9	6.0	7.1	TB1 / TB2	FNN 1)	FNN with fan	SD (with shiftable linkage)	3b / 3Na / 4N	DKM / ZS-DKM	ZR	ZRS	Brake drum (steel)		Brake disk (steel)	
	Steel, GJS, Al-H	GJL, sinter metal	Al-D												Outside Ø [mm]	[rpm]	Outside Ø [mm]	[rpm]
14	10000	10000	3600	-											160	6000	200	8600
19	10000	10000	3600	10000											200	4800	250	6850
24	10000	10000	3600	8600											250	3800	315	5500
28	10000	10000	3600	7300											315	3000	355	4850
38	9500	8300	3600	6000											400	2400	400	4300
42	8000	7000	3600	5000											500	1900	450	3800
48	7200	6300	3600	4500											630	1500	500	3500
55	6300	5500	-	4000											630	1500	560	3050
65	5600	4900	-	3600											710	1350	630	2700
75	4700	4200	-	3000											710	1350	710	2400
90	3800	3600	-	2400											800	1200	800	2150
100	3600	-	-	2100													900	1900
110	3000	-	-	1900													1000	1700
125	2600	-	-	1800														
140	2400	-	-	1500														
160	2000	-	-	1300														
180	1800	-	-	1150														
Balancing necessary from a circumferential speed of	v = 30 m/s	v = 30 m/s	On request	v = 20 m/s											v = 30 m/s		v = 30 m/s	

Depending on the application, balancing may also be required with lower circumferential speeds.  
Higher speeds possible on request.

<sup>1)</sup> Please note that the attachments may have a lower permissible maximum speed.

## Displacements

Axial displacement  $\Delta K_a$

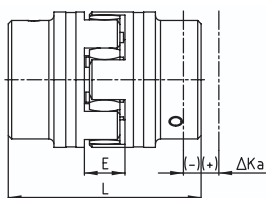

$$L_{max} = L + \Delta K_a$$

Radial displacement  $\Delta K_r$

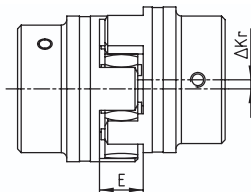

Angular displacement  $\Delta K_w$  [degree]

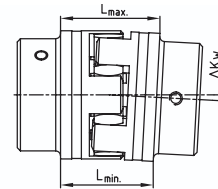

$$\Delta K_w [mm] = L_{max} - L_{min}$$

### Displacements for spider 92 and 98 Shore A

ROTEX® size	14	19	24	28	38	42	48	55	65	75	90	100	110	125	140	160	180
Max. axial displacement $\Delta K_a$ [mm]	-0.5 +1.0	-0.5 +1.2	-0.5 +1.4	-0.7 +1.5	-0.7 +1.8	-1.0 +2.0	-1.0 +2.1	-1.0 +2.2	-1.0 +2.6	-1.5 +3.0	-1.5 3.4	-1.5 +3.8	-2.0 +4.2	-2.0 +4.6	-2.0 +5.0	-2.5 +5.7	-3.0 +6.4
Max. radial displacement with n=1500 rpm $\Delta K_r$ [mm]	0.17	0.20	0.22	0.25	0.28	0.32	0.36	0.38	0.42	0.48	0.50	0.52	0.55	0.60	0.62	0.64	0.68
Max. angular displacement with n=1500 rpm $\Delta K_w$ [degree]	1.2	1.2	0.9	0.9	1.0	1.0	1.1	1.1	1.2	1.2	1.2	1.2	1.3	1.3	1.2	1.2	1.2
$\Delta K_w$ [mm]	0.67	0.82	0.85	1.05	1.35	1.70	2.00	2.30	2.70	3.30	4.30	4.80	5.60	6.50	6.60	7.60	9.00

### Displacements for spider 64 Shore D

ROTEX® size	14	19	24	28	38	42	48	55	65	75	90	100	110	125	140	160	180
Max. axial displacement $\Delta K_a$ [mm]	-0.5 +1.0	-0.5 +1.2	-0.5 +1.4	-0.7 +1.5	-0.7 +1.8	-1.0 +2.0	-1.0 +2.1	-1.0 +2.2	-1.0 +2.6	-1.5 +3.0	-1.5 +3.4	-1.5 +3.8	-2.0 +4.2	-2.0 +4.6	-2.0 +5.0	-2.5 +5.7	-3.0 +6.4
Max. radial displacement with n=1500 rpm $\Delta K_r$ [mm]	0.11	0.13	0.15	0.18	0.21	0.23	0.25	0.27	0.30	0.34	0.36	0.37	0.40	0.43	0.45	0.46	0.49
Max. angular displacement with n=1500 rpm $\Delta K_w$ [degree]	1.1	1.1	0.8	0.8	0.9	0.9	1.0	1.0	1.1	1.1	1.1	1.1	1.2	1.2	1.1	1.1	1.1
$\Delta K_w$ [mm]	0.57	0.76	0.76	0.90	1.25	1.40	1.80	2.00	2.50	3.00	3.80	4.30	5.30	6.00	6.10	7.10	8.00

### Displacements for spider PA, PEEK

ROTEX® size	14	19	24	28	38	42	48	55	65	75	90	100	110	125	140
Max. axial displacement $\Delta K_a$ [mm]	-0.5 +1.0	-0.5 +1.2	-0.5 +1.4	-0.7 +1.5	-0.7 +1.8	-1.0 +2.0	-1.0 +2.1	-1.0 +2.2	-1.0 +2.6	-1.5 +3.0	-1.5 +3.4	-1.5 +3.8	-2.0 +4.2	-2.0 +4.6	-2.0 +5.0
Max. radial displacement with n=1500 rpm $\Delta K_r$ [mm]	0.08	0.10	0.11	0.12	0.14	0.16	0.18	0.19	0.21	0.24	0.25	0.26	0.27	0.30	0.31
Max. angular displacement with n=1500 rpm $\Delta K_w$ [degree]	0.60	0.45	0.45	0.50	0.50	0.55	0.55	0.55	0.60	0.60	0.60	0.60	0.65	0.65	0.60
$\Delta K_w$ [mm]	0.33	0.41	0.42	0.52	0.67	0.85	1.00	1.15	1.35	1.65	2.15	2.40	2.80	3.25	3.30

The specified permissible displacement figures of the flexible ROTEX® couplings are standard values taking into account the load of the coupling up to the rated torque  $T_{KN}$  and an operating speed  $n = 1500$  rpm along with an ambient temperature of +30 °C.

The displacement figures may only be used one by one, if they appear simultaneously, they must be limited in proportion. Care should be taken to maintain the distance dimension E accurately in order to allow for axial clearance of the coupling while in operation. Detailed mounting instructions are shown on our homepage [www.ktr.com](http://www.ktr.com).

# ROTEX® Flexible jaw couplings

## Properties of standard spiders

ROTEX® 14



ROTEX® 19

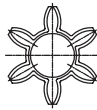

ROTEX® 24 - 65

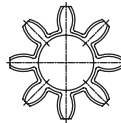

ROTEX® 75 - 160

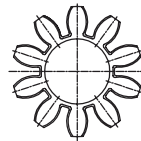



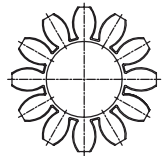



ROTEX® 180



### Degree of hardness



Spider type (Shore hardness)	92 Shore A (T-PUR®)	98 Shore A (T-PUR®)
	 T-PUR®	 T-PUR®
Size	14 to 180	14 to 180
Material	T-PUR®	T-PUR®
Permissible temperature range		
Permanent temperature	-40 °C to +120 °C	-40 °C to +120 °C
Short-term temperature	-40 °C to +150 °C	-40 °C to +150 °C
Features	<ul style="list-style-type: none"> <li>– significantly higher service life expectancy</li> <li>– very good temperature resistance</li> <li>– improved damping of vibrations</li> <li>– good damping, medium flexibility</li> <li>– suitable for all hub materials</li> </ul>	<ul style="list-style-type: none"> <li>– significantly higher service life expectancy</li> <li>– very good temperature resistance</li> <li>– improved damping of vibrations</li> <li>– transmission of high torques with medium damping</li> <li>– recommended hub material: steel, GJL and GJS</li> </ul>
Spider type (Shore hardness)	64 Shore D (T-PUR®)	52 Shore D-S-GS
	 T-PUR®	
Size	14 to 180	19 to 42
Material	T-PUR®	Polyurethane (PUR)
Permissible temperature range		
Permanent temperature	-40 °C to +120 °C	-40 °C to +120 °C
Short-term temperature	-40 °C to +150 °C	-50 °C to +150 °C
Features	<ul style="list-style-type: none"> <li>– significantly higher service life expectancy</li> <li>– very good temperature resistance</li> <li>– improved damping of vibrations</li> <li>– transmission of very high torques with low damping</li> <li>– recommended hub material: steel and GJS</li> </ul>	<ul style="list-style-type: none"> <li>– significantly higher service life expectancy</li> <li>– very good temperature resistance</li> <li>– improved damping of vibrations</li> <li>– transmission of high torques with medium damping</li> <li>– recommended hub material: steel, GJL and GJS</li> </ul>
Spider type (Shore hardness)	PA	PEEK
		
Size	14 to 125	14 to 125
Material	Polyamide	Polyetheretherketone
Permissible temperature range		
Permanent temperature	-40 °C to +100 °C <sup>1)</sup>	up to +180 °C
Short-term temperature	-40 °C to +120 °C <sup>1)</sup>	up to +250 °C
Features	<ul style="list-style-type: none"> <li>– small twisting angle and high torsion spring stiffness</li> <li>– transmission of very high torques with very low damping</li> <li>– good resistance to chemicals <sup>1)</sup></li> <li>– recommended hub material: steel</li> <li>– high restoring forces with displacements</li> </ul>	<ul style="list-style-type: none"> <li>– small twisting angle and high torsion spring stiffness</li> <li>– transmission of very high torques with very low damping</li> <li>– highly temperature-resistant, resistant to hydrolysis</li> <li>– good resistance to chemicals</li> <li>– recommended hub material: steel</li> <li>– high restoring forces with displacements</li> </ul>

<sup>1)</sup> different properties depending on compound

## Technical data of standard spiders

92 Shore A spider made of T-PUR® and PUR														
ROTEX® size	Torsion angle $\phi$ with		Torque [Nm]					Damping power P <sub>KW</sub> [W] <sup>3)</sup>	Relative damping $\psi$	Resonance factor V <sub>R</sub>	Torsion spring stiffness C dyn. [Nm/rad]			
			DIN 740 <sup>1)</sup>			T <sub>K max</sub> <sup>2)</sup>	1.0 T <sub>KN</sub>				0.75 T <sub>KN</sub>	0.5 T <sub>KN</sub>	0.25 T <sub>KN</sub>	
	T <sub>KN</sub>	T <sub>K max</sub>	Rated T <sub>KN</sub>	Max. T <sub>K max</sub>	Vibratory T <sub>KW</sub>									
14	6.4°	10°	7.5	15	2.0	22.5	—			0.38x10 <sup>3</sup>	0.31x10 <sup>3</sup>	0.24x10 <sup>3</sup>	0.14x10 <sup>3</sup>	
19			10	20	2.6	30	4.8			1.28x10 <sup>3</sup>	1.05x10 <sup>3</sup>	0.8x10 <sup>3</sup>	0.47x10 <sup>3</sup>	
24			35	70	9.1	105	6.6			4.86x10 <sup>3</sup>	3.98x10 <sup>3</sup>	3.01x10 <sup>3</sup>	1.79x10 <sup>3</sup>	
28			95	190	25	285	8.4			10.9x10 <sup>3</sup>	8.94x10 <sup>3</sup>	6.76x10 <sup>3</sup>	4.01x10 <sup>3</sup>	
38			190	380	49	570	10.2			21.05x10 <sup>3</sup>	17.26x10 <sup>3</sup>	13.05x10 <sup>3</sup>	7.74x10 <sup>3</sup>	
42			265	530	69	795	12.0			23.74x10 <sup>3</sup>	19.47x10 <sup>3</sup>	14.72x10 <sup>3</sup>	8.73x10 <sup>3</sup>	
48			310	620	81	930	13.8			36.7x10 <sup>3</sup>	30.09x10 <sup>3</sup>	22.75x10 <sup>3</sup>	13.49x10 <sup>3</sup>	
55			410	820	107	1230	15.6			50.7x10 <sup>3</sup>	41.59x10 <sup>3</sup>	31.45x10 <sup>3</sup>	18.64x10 <sup>3</sup>	
65	3.2°	5°	625	1250	163	1875	18.0	0.80	7.90	97.1x10 <sup>3</sup>	79.65x10 <sup>3</sup>	60.2x10 <sup>3</sup>	35.7x10 <sup>3</sup>	
75			1280	2560	333	3840	21.6			113.3x10 <sup>3</sup>	92.9x10 <sup>3</sup>	70.3x10 <sup>3</sup>	41.65x10 <sup>3</sup>	
90			2400	4800	624	7200	30.0			190.1x10 <sup>3</sup>	155.9x10 <sup>3</sup>	117.9x10 <sup>3</sup>	69.9x10 <sup>3</sup>	
100			3300	6600	858	9900	36.0			253.1x10 <sup>3</sup>	207.5x10 <sup>3</sup>	156.9x10 <sup>3</sup>	93x10 <sup>3</sup>	
110			4800	9600	1248	14400	42.0			415.5x10 <sup>3</sup>	336.9x10 <sup>3</sup>	257.6x10 <sup>3</sup>	177.4x10 <sup>3</sup>	
125			6650	13300	1729	19950	48.0			647.7x10 <sup>3</sup>	537.3x10 <sup>3</sup>	412.2x10 <sup>3</sup>	277.5x10 <sup>3</sup>	
140			8550	17100	2223	25650	54.6			813.4x10 <sup>3</sup>	670.2x10 <sup>3</sup>	519.7x10 <sup>3</sup>	351.7x10 <sup>3</sup>	
160			12800	25600	3328	38400	75.0			1298x10 <sup>3</sup>	1104x10 <sup>3</sup>	901.9x10 <sup>3</sup>	655.7x10 <sup>3</sup>	
180			18650	37300	4849	55950	78.0			2327x10 <sup>3</sup>	1981x10 <sup>3</sup>	1618x10 <sup>3</sup>	1176x10 <sup>3</sup>	

98 Shore A spider made of T-PUR® and PUR														
ROTEX® size	Torsion angle $\phi$ with		Torque [Nm]					Damping power P <sub>KW</sub> [W] <sup>3)</sup>	Relative damping $\psi$	Resonance factor V <sub>R</sub>	Torsion spring stiffness C dyn. [Nm/rad]			
			DIN 740 <sup>1)</sup>			T <sub>K max</sub> <sup>2)</sup>	1.0 T <sub>KN</sub>				0.75 T <sub>KN</sub>	0.5 T <sub>KN</sub>	0.25 T <sub>KN</sub>	
	T <sub>KN</sub>	T <sub>K max</sub>	Rated T <sub>KN</sub>	Max. T <sub>K max</sub>	Vibratory T <sub>KW</sub>									
14	6.4°	10°	12.5	25	3.3	37.5	—			0.56x10 <sup>3</sup>	0.46x10 <sup>3</sup>	0.35x10 <sup>3</sup>	0.21x10 <sup>3</sup>	
19			17	34	4.4	51	4.8			2.92x10 <sup>3</sup>	2.39x10 <sup>3</sup>	1.81x10 <sup>3</sup>	1.07x10 <sup>3</sup>	
24			60	120	16	180	6.6			9.93x10 <sup>3</sup>	8.14x10 <sup>3</sup>	6.16x10 <sup>3</sup>	3.65x10 <sup>3</sup>	
28			160	320	42	480	8.4			26.77x10 <sup>3</sup>	21.95x10 <sup>3</sup>	16.6x10 <sup>3</sup>	9.84x10 <sup>3</sup>	
38			325	650	85	975	10.2			48.57x10 <sup>3</sup>	39.83x10 <sup>3</sup>	30.11x10 <sup>3</sup>	17.85x10 <sup>3</sup>	
42			450	900	117	1350	12.0			54.5x10 <sup>3</sup>	44.69x10 <sup>3</sup>	33.79x10 <sup>3</sup>	20.03x10 <sup>3</sup>	
48			525	1050	137	1575	13.8			65.3x10 <sup>3</sup>	53.54x10 <sup>3</sup>	40.48x10 <sup>3</sup>	24x10 <sup>3</sup>	
55			685	1370	178	2055	15.6			95x10 <sup>3</sup>	77.9x10 <sup>3</sup>	58.88x10 <sup>3</sup>	34.9x10 <sup>3</sup>	
65	3.2°	5°	940	1880	244	2820	18.0	0.80	7.90	129.5x10 <sup>3</sup>	106.2x10 <sup>3</sup>	80.3x10 <sup>3</sup>	47.6x10 <sup>3</sup>	
75			1920	3840	499	5760	21.6			197.5x10 <sup>3</sup>	162x10 <sup>3</sup>	122.5x10 <sup>3</sup>	72.6x10 <sup>3</sup>	
90			3600	7200	936	10800	30.0			312.2x10 <sup>3</sup>	256x10 <sup>3</sup>	193.6x10 <sup>3</sup>	114.7x10 <sup>3</sup>	
100			4950	9900	1287	14850	36.0			383.3x10 <sup>3</sup>	314.3x10 <sup>3</sup>	237.6x10 <sup>3</sup>	140.9x10 <sup>3</sup>	
110			7200	14400	1872	21600	42.0			805.9x10 <sup>3</sup>	663.1x10 <sup>3</sup>	515.3x10 <sup>3</sup>	360.5x10 <sup>3</sup>	
125			10000	20000	2600	30000	48.0			1207x10 <sup>3</sup>	1003x10 <sup>3</sup>	787.6x10 <sup>3</sup>	552.5x10 <sup>3</sup>	
140			12800	25600	3328	38400	54.6			1549x10 <sup>3</sup>	1283x10 <sup>3</sup>	979.8x10 <sup>3</sup>	674.1x10 <sup>3</sup>	
160			19200	38400	4992	57600	75.0			2481x10 <sup>3</sup>	2137x10 <sup>3</sup>	1781x10 <sup>3</sup>	1275x10 <sup>3</sup>	
180			28000	56000	7280	84000	78.0			4220x10 <sup>3</sup>	3635x10 <sup>3</sup>	3031x10 <sup>3</sup>	2170x10 <sup>3</sup>	

64 Shore D spider made of T-PUR®														
ROTEX® size	Torsion angle $\phi$ with		Torque [Nm]					Damping power P <sub>KW</sub> [W] <sup>3)</sup>	Relative damping $\psi$	Resonance factor V <sub>R</sub>	Torsion spring stiffness C dyn. [Nm/rad]			
			DIN 740 <sup>1)</sup>			T <sub>K max</sub> <sup>2)</sup>	1.0 T <sub>KN</sub>				0.75 T <sub>KN</sub>	0.5 T <sub>KN</sub>	0.25 T <sub>KN</sub>	
	T <sub>KN</sub>	T <sub>K max</sub>	Rated T <sub>KN</sub>	Max. T <sub>K max</sub>	Vibratory T <sub>KW</sub>									
14	4.5°	7.0°	16	32	4.2	48	9.0			0.76x10 <sup>3</sup>	0.62x10 <sup>3</sup>	0.47x10 <sup>3</sup>	0.28x10 <sup>3</sup>	
19			21	42	5.5	63	7.2			5.35x10 <sup>3</sup>	4.39x10 <sup>3</sup>	3.32x10 <sup>3</sup>	1.97x10 <sup>3</sup>	
24			75	150	19.5	225	9.9			15.11x10 <sup>3</sup>	12.39x10 <sup>3</sup>	9.37x10 <sup>3</sup>	5.55x10 <sup>3</sup>	
28			200	400	52	600	12.6			27.52x10 <sup>3</sup>	22.57x10 <sup>3</sup>	17.06x10 <sup>3</sup>	10.12x10 <sup>3</sup>	
38			405	810	105	1215	15.3			70.15x10 <sup>3</sup>	57.52x10 <sup>3</sup>	43.49x10 <sup>3</sup>	25.78x10 <sup>3</sup>	
42			560	1120	146	1680	18.0			79.9x10 <sup>3</sup>	65.5x10 <sup>3</sup>	49.52x10 <sup>3</sup>	29.35x10 <sup>3</sup>	
48			655	1310	170	1965	20.7			95.5x10 <sup>3</sup>	78.3x10 <sup>3</sup>	59.22x10 <sup>3</sup>	35.1x10 <sup>3</sup>	
55			825	1650	215	2475	23.4			107.9x10 <sup>3</sup>	88.5x10 <sup>3</sup>	66.9x10 <sup>3</sup>	39.66x10 <sup>3</sup>	
65	2.5°	3.6°	1175	2350	306	3525	27.0	0.75	8.50	151.1x10 <sup>3</sup>	123.9x10 <sup>3</sup>	93.7x10 <sup>3</sup>	55.53x10 <sup>3</sup>	
75			2400	4800	624	7200	32.4			248.2x10 <sup>3</sup>	203.5x10 <sup>3</sup>	153.9x10 <sup>3</sup>	91.2x10 <sup>3</sup>	
90			4500	9000	1170	13500	45.0			674.5x10 <sup>3</sup>	553.1x10 <sup>3</sup>	418.2x10 <sup>3</sup>	247.9x10 <sup>3</sup>	
100			6185	12370	1608	18555	54.0			861.2x10 <sup>3</sup>	706.2x10 <sup>3</sup>	533.9x10 <sup>3</sup>	316.5x10 <sup>3</sup>	
110			9000	18000	2340	27000	63.0			1230x10 <sup>3</sup>	1001x10 <sup>3</sup>	773.1x10 <sup>3</sup>	531.4x10 <sup>3</sup>	
125			12500	25000	3250	37500	72.0			1749x10 <sup>3</sup>	1436x10 <sup>3</sup>	1149x10 <sup>3</sup>	832.1x10 <sup>3</sup>	
140			16000	32000	4160	48000	81.9			2312x10 <sup>3</sup>	1929x10 <sup>3</sup>	1521x10 <sup>3</sup>	1082x10 <sup>3</sup>	
160			24000	48000	6240	72000	112.5			3415x10 <sup>3</sup>	2961x10 <sup>3</sup>	2471x10 <sup>3</sup>	1830x10 <sup>3</sup>	
180			35000	70000	9100	105000	117.0			5670x10 <sup>3</sup>	4917x10 <sup>3</sup>	4103x10 <sup>3</sup>	3038x10 <sup>3</sup>	

<sup>1)</sup> see catalogue page 15

<sup>2)</sup> ≤ 1000 load cycles

<sup>3)</sup> with +30 °C

Temperature factor S <sub>t</sub>										
	-40 °C +30 °C	+40 °C	+50 °C	+60 °C	+70 °C	+80 °C	+90 °C	+100 °C	+110 °C	+120 °C
T-PUR®	1.0	1.0	1.2	1.3	1.45	1.6	1.8	2.1	2.5	3.0
PUR	1.0	1.0	1.3	1.4	1.55	1.8	2.2	—	—	—

With temperatures below -40 °C consult with KTR.

Unless the Shore hardness of spider is explicitly specified in your order, we will supply spiders with Shore hardness 92 Shore A T-PUR®.

For circumferential speeds exceeding v = 30 m/s dynamic balancing is required. For circumferential speeds exceeding v = 35 m/s only steel or nodular iron.

### Technical data and properties of special spiders

Torques				
ROTEX® size	Material	T <sub>KN</sub> [Nm]	T <sub>K max</sub> [Nm]	T <sub>KW</sub> [Nm]
14	PA	22	44	5.5
	PEEK			
19	PA	30	60	8.0
	PEEK			
	52 ShD-S-GS			
24	PA	105	210	27.5
	PEEK			
	52 ShD-S-GS			
28	PA	280	560	73
	PEEK			
	52 ShD-S-GS			
38	PA	565	1130	147
	PEEK			
	52 ShD-S-GS			
42	PA	785	1570	204
	PEEK			
	52 ShD-S-GS			
48	PA	915	1830	238
	PEEK			
55	PA	1200	2400	312
	PEEK			
65	PA	1645	3290	427
	PEEK			
75	PA	2560	5130	667
	PEEK			
90	PA	6300	12600	1640
	PEEK			
100	PA	8650	17300	2250
	PEEK			
110	PA	10500	21000	2730
	PEEK			
125	PA	13000	26000	3380
	PEEK			

Temperature factor S <sub>t</sub>										
	-40 °C +30 °C	+40 °C	+50 °C	+60 °C	+70 °C	+80 °C	+90 °C	+100 °C	+110 °C	+120 °C
PA	1.0	1.0	1.0	1.0	1.2	1.4	1.6	—	—	—
PEEK	1.0	1.0	1.0	1.0	1.0	1.0	1.0	1.0	1.0	1.0
52 ShD-S-GS	1.0	1.0	1.0	1.0	1.2	1.3	1.4	1.55	1.8	2.2

With temperatures below -40 °C consult with KTR.

### Installation of spider

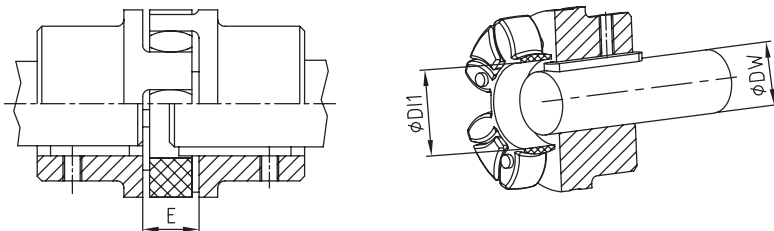

Shaft ØDW with feather key (acc. to DIN 6885 sheet 1) protruding into the spider ØD1

Mounting dimensions																	
ROTEX® size	14	19	24	28	38	42	48	55	65	75	90	100	110	125	140	160	180
Distance dimension E [mm]	13	16	18	20	24	26	28	30	35	40	45	50	55	60	65	75	85
Dimension D1 [mm] <sup>1)</sup>	10	18	27	30	38	46	51	60	68	80	100	113	127	147	165	190	220
Dimension DW [mm] <sup>2)</sup>	7	12	20	22	28	36	40	48	55	65	80	95	100	120	135	160	185

<sup>1)</sup> Spider 52 ShD-S-GS D1=0

<sup>2)</sup> If the shaft diameter is smaller than or equal to dimension D1, one shaft end or both shaft ends may protrude with the feather keyway into the spider.

## Selection of standard IEC motors

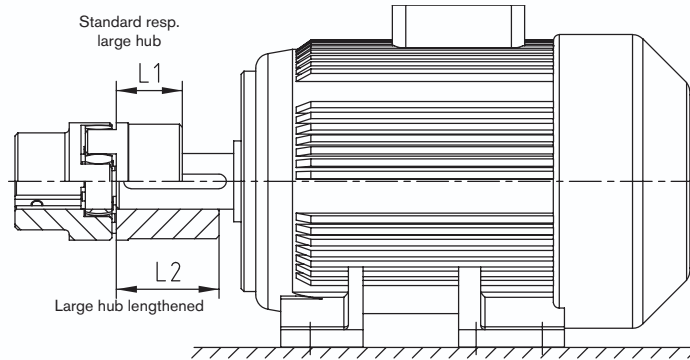

ROTEX® couplings for standard IEC motors, protection class IP 54/IP 55 (spider 98 Shore A)													
A. C. motor 50 Hz		Motor 2 poles n= 3000 rpm		ROTEX® coupling size	Motor 4 poles n= 1500 rpm		ROTEX® coupling size	Motor 6 poles n= 1000 rpm		ROTEX® coupling size	Motor 8 poles n= 750 rpm		ROTEX® coupling size
Size	Shaft end DxL [mm]	Power P [kW]	Torque T <sub>AN</sub> [Nm]		Power P [kW]	Torque T <sub>AN</sub> [Nm]		Power P [kW]	Torque T <sub>AN</sub> [Nm]		Power P [kW]	Torque T <sub>AN</sub> [Nm]	
63	11 x 23	0.18	0.62	14	0.12	0.88	14	0.06	0.7	14			
		0.25	0.86		0.18	1.3		0.09	1.1		0.04	0.6	
71	14 x 30	0.37	1.3	19	0.25	1.8	19	0.18	2	19	0.09	1.4	14
		0.55	1.9		0.37	2.5		0.25	2.8		0.12	1.8	
80	19 x 40	0.75	2.5	24	0.55	3.7	24	0.37	3.9	24	0.18	2.5	19
		1.1	3.7		0.75	5.1		0.55	5.8		0.25	3.5	
90S	24 x 50	1.5	5	28	1.1	7.5	28	0.75	8	28	0.37	5.3	19
90L		2.2	7.4		1.5	10		1.1	12		0.55	7.9	
100L	28 x 60	3	9.8	38	2.2	15	38	1.5	15	38	0.75	11	24
112M		4	13		3	20		2.2	22		1.5	16	
132S	38 x 80	5.5	18	42	5.5	36	42	3	30	42	2.2	30	28
		7.5	25		7.5	49		4	40		3	40	
132M								5.5	55				
160M	42 x 110	11	36	48	11	72	48	7.5	75	48	4	54	
		15	49		15	98		11	109		5.5	74	
160L	48 x 110	18.5	60	55	18.5	121	55	15	148	55	7.5	100	38
180M		22	71		22	144		15	181		11	145	
180L								18.5	181		15	198	42
200L	55 x 110	30	97	65	30	196	65	22	215	65			
		37	120		37	240		30	293		18.5	244	
225S	55 x 110	45	145	75	45	292	75	30	293	75	22	290	48
225M		55	177		55	356		37	361		30	392	
250M	60 x 140	65 x 140	75	241	55	581	65	45	438	55	37	483	65
280S	75 x 140	90	289	75	90	581	75	55	535	75	45	587	65
280M		110	353		110	707		75	727		55	712	
315S	65 x 140	132	423	90	132	849	90	90	873	90	75	971	75
315M		160	513		160	1030		110	1070		90	1170	
315L	80 x 170	200	641	100	200	1290	100	132	1280	100	110	1420	90
315		85 x 170	250		802	250		1600	200		1930	160	
	315		315	1010	315	2020	250	2410	200	2580	200	2580	200
355	75 x 140	355	1140	110	355	2280	110			110			100
		400	1280		400	2570		315	3040		250	3220	
400	80 x 170	500	1600	125	500	3210	125	400	3850	125	315	4060	110
		560	1790		560	3580		450	4330		355	4570	
450	90 x 170	630	2020	140	630	4030	140	500	4810	140	400	5150	125
		710	2270		710	4540		560	5390		450	5790	
450	120 x 210	800	2560	140	800	5120	140	630	6060	140	500	6420	140
		900	2880		900	5760		710	6830		560	7190	
		1000	3200		1000	6400		800	7690		630	8090	

The coupling selection is based on an ambient temperature of up to +40 °C. The selection is based on a minimum safety factor of 2 to the max. coupling torque (T<sub>K max</sub>). A detailed selection is possible according to catalogue page 14 et seqq. Drives with periodical torque curves must be selected according to DIN 740 part 2. If requested, KTR will perform the selection. Torque T = rated torque according to Siemens-catalogue DB1.1 04/2024

# ROTEX® Flexible jaw couplings

## Cylindrical bores and inch bores

Bore ØD		Width of keyway B		Keyway depth T2	KTR code Inch bore	ROTEX® basic bores, available from stock Hub material aluminium ●; hub material steel ●; hub material EN-GJL ●										
ØD [mm]	ØD [inch]	B [mm]	B [inch]	T2 [mm]		ROTEX® sizes										
						14	19	24	28	38	42	48	55	65	75	90
Ø6 H7 +0.012		2 JS9 ±0.0125		7 +0.1		●										
Ø8 H7 +0.015		2 JS9 ±0.0125		9 +0.1		●●	●●									
Ø9 H7 +0.015		3 JS9 ±0.0125		10.4 +0.1		●●	●									
Ø9.525 +0.0254	3/8	3.175 +0.051	1/8	10.972 +0.381	Tb											
Ø10 H7 +0.015		3 JS9 ±0.0125		11.4 +0.1		●●	●●	●●								
Ø11 H7 +0.018		4 JS9 ±0.015		12.8 +0.1		●●	●●	●								
Ø11.112 +0.0254	7/16	2.382 +0.051	3/32	12.293 +0.381	DNB											
Ø12 H7 +0.018		4 JS9 ±0.015		13.8 +0.1		●●	●●	●●								
Ø12.7 +0.0254	1/2	3.175 +0.051	1/8	14.224 +0.381	Ta		●	●								
Ø12.7 +0.0254	1/2	4.762 +0.051	3/16	14.757 +0.381	T											
Ø13.495 +0.0254	17/32	3.175 +0.051	1/8	15.011 +0.381	DNC											
Ø14 H7 +0.018		5 JS9 ±0.015		16.3 +0.1		●●	●●	●●	●●							
Ø14.287 +0.0254	9/16	3.175 +0.051	1/8	15.824 +0.381	Do											
Ø15 H7 +0.018		5 JS9 ±0.015		17.3 +0.1		●●	●●	●●	●							
Ø15.875 +0.0254	5/8	3.175 +0.051	1/8	17.424 +0.381	E											
Ø15.875 +0.0254	5/8	3.968 +0.051	5/32	17.729 +0.381	Es											
Ø15.875 +0.0254	5/8	4.762 +0.051	3/16	18.008 +0.381	Ed		●	●								
Ø16 H7 +0.018		5 JS9 ±0.015		18.3 +0.1		●●	●●	●●	●●							
Ø17 H7 +0.018		5 JS9 ±0.015		19.3 +0.1			●●	●●	●							
Ø17.462 +0.0254	11/16	4.762 +0.051	3/16	19.634 +0.381	DNH											
Ø18 H7 +0.018		6 JS9 ±0.015		20.8 +0.1		●●	●●	●●	●●	●						
Ø19 H7 +0.021		6 JS9 ±0.015		21.8 +0.1		●●	●●	●●	●●	●						
Ø19.05 +0.0254	3/4	3.175 +0.051	1/8	20.624 +0.381	Ad											
Ø19.05 +0.0254	3/4	4.762 +0.051	3/16	21.259 +0.381	A		●	●	●	●						
Ø20 H7 +0.021		6 JS9 ±0.015		22.8 +0.1		●●	●●	●●	●●	●●						
Ø22 H7 +0.021		6 JS9 ±0.015		24.8 +0.1		●	●	●	●	●	●					
Ø22.225 +0.0254	7/8	4.762 +0.051	3/16	24.485 +0.381	G											
Ø22.225 +0.0254	7/8	6.35 +0.051	1/4	25.069 +0.381	F											
Ø23.812 +0.0254	15/16	6.35 +0.051	1/4	26.695 +0.381	Gf											
Ø24 H7 +0.021		8 JS9 ±0.018		27.3 +0.2		●●	●●	●●	●●	●●	●					
Ø25 H7 +0.021		8 JS9 ±0.018		28.3 +0.2		●	●	●	●	●	●	●				
Ø25.4 +0.0254	1	4.762 +0.051	3/16	27.686 +0.381	H											
Ø25.4 +0.0254	1	6.35 +0.051	1/4	28.295 +0.381	Hs											
Ø26.987 +0.0254	1 1/16	4.762 +0.051	3/16	29.286 +0.381	R											
Ø28 H7 +0.021		8 JS9 ±0.018		31.3 +0.2			●●	●●	●●	●●	●●	●				
Ø28.575 +0.0254	1 1/8	6.35 +0.051	1/4	31.521 +0.381	Sb		●	●								
Ø28.575 +0.0254	1 1/8	7.937 +0.051	5/16	32.105 +0.381	Sd											
Ø30 H7 +0.021		8 JS9 ±0.018		33.3 +0.2			●	●	●	●	●	●	●			
Ø31.75 +0.0254	1 1/4	6.35 +0.051	1/4	34.721 +0.381	Js											
Ø31.75 +0.0254	1 1/4	7.937 +0.051	5/16	35.331 +0.381	K											
Ø32 H7 +0.025		10 JS9 ±0.018		35.3 +0.2			●●	●●	●●	●●	●●	●●	●			
Ø34.925 +0.0254	1 3/8	7.937 +0.051	5/16	38.557 +0.381	Ma											
Ø34.925 +0.0254	1 3/8	9.525 +0.0635	3/8	39.141 +0.381	RH1											
Ø35 H7 +0.025		10 JS9 ±0.018		38.3 +0.2					●●	●●	●●	●●	●●	●		
Ø36.512 +0.0254	1 7/16	9.525 +0.0635	3/8	40.767 +0.381	Cb											
Ø38 H7 +0.025		10 JS9 ±0.018		41.3 +0.2					●●	●●	●●	●●	●●	●		
Ø38.1 +0.0254	1 1/2	7.937 +0.051	5/16	41.783 +0.381	Ca											
Ø38.1 +0.0254	1 1/2	9.525 +0.0635	3/8	42.392 +0.381	C											
Ø40 H7 +0.025		12 JS9 ±0.0215		43.3 +0.2					●	●	●	●	●	●	●	
Ø41.275 +0.0254	1 5/8	9.525 +0.0635	3/8	45.618 +0.381	Nb											
Ø42 H7 +0.025		12 JS9 ±0.0215		45.3 +0.2						●●	●●	●●	●●	●●	●	
Ø44.45 +0.0254	1 3/4	9.525 +0.0635	3/8	48.818 +0.381	Ls											
Ø44.45 +0.0254	1 3/4	11.112 +0.0635	7/16	49.428 +0.381	L											
Ø45 H7 +0.025		14 JS9 ±0.0215		48.8 +0.2						●●	●●	●●	●●	●●	●●	
Ø47.625 +0.0254	1 7/8	12.7 +0.0635	1/2	53.238 +0.381	Lu											
Ø48 H7 +0.025		14 JS9 ±0.0215		51.8 +0.2						●●	●●	●●	●●	●●	●●	
Ø49.212 +0.0254	1 15/16	12.7 +0.0635	1/2	54.864 +0.381	Da											
Ø50 H7 +0.025		14 JS9 ±0.0215		53.8 +0.2							●●	●●	●●	●●	●●	●
Ø50.8 +0.0254	2	12.7 +0.0635	1/2	56.464 +0.381	Ds											
Ø53.975 +0.0381	2 1/8	12.7 +0.0635	1/2	59.69 +0.381	Pa											
Ø55 H7 +0.03		16 JS9 ±0.0215		59.3 +0.2							●●	●●	●●	●●	●●	●
Ø57.15 +0.0381	2 1/4	12.7 +0.0635	1/2	62.915 +0.381	U											
Ø60 H7 +0.03		18 JS9 ±0.0215		64.4 +0.2												
Ø60.325 +0.0381	2 3/8	15.875 +0.076	5/8	67.335 +0.381	Ub											
Ø65 H7 +0.03		18 JS9 ±0.0215		69.4 +0.2												
Ø70 H7 +0.03		20 JS9 ±0.026		74.9 +0.2												
Ø75 H7 +0.03		20 JS9 ±0.026		79.9 +0.2												
Ø80 H7 +0.03		22 JS9 ±0.026		85.4 +0.2												
Ø85 H7 +0.035		22 JS9 ±0.026		90.4 +0.2												
Ø85.725 +0.0381	3 3/8	22.225 +0.076	7/8	95.504 +0.381	Wd											
Ø90 H7 +0.035		25 JS9 ±0.026		95.4 +0.2												
Ø92.075 +0.0381	3 5/8	22.225 +0.076	7/8	101.955 +0.381	Wf											
Ø100 H7 +0.035		28 JS9 ±0.026		106.4 +0.2												●

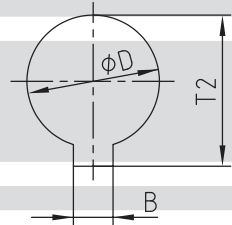

For manufacturing reasons KTR reserves the right to insert a recess on the cam side.

### Spline bores

#### Basic range ANSI B92.1-involute spline

Spline code	Size	Pitch circle	pitch	No. of teeth	Angle	Spline code	Size	Pitch circle	pitch	No. of teeth	Angle
PH-S	$\frac{5}{8}$ "	14.28	16/32	9	30°	PS-S	$1\frac{1}{2}$ "	35.98	12/24	17	30°
PI-S	$\frac{3}{4}$ "	17.46	16/32	11	30°	PD-S	$1\frac{1}{2}$ "	36.51	16/32	23	30°
PB-S	$\frac{7}{8}$ "	20.63	16/32	13	30°	PE-S	$1\frac{3}{4}$ "	42.86	16/32	27	30°
PB-BS	1"	23.81	16/32	15	30°	PK-S	$1\frac{3}{4}$ "	41.275	8/16	13	30°
PJ	$1\frac{1}{8}$ "	26.98	16/32	17	30°	PT-C <sup>1)</sup>	2"	47.625	8/16	15	30°
PC-S	$1\frac{1}{4}$ "	29.63	12/24	14	30°	PQ-C <sup>1)</sup>	$2\frac{1}{4}$ "	53.975	8/16	17	30°
PA-S	$1\frac{3}{8}$ "	33.33	16/32	21	30°						

#### Basic programme of spline bores acc. to DIN 5482

Size	Pitch circle	Module	No. of teeth	Profile correction	Size	Pitch circle	Module	No. of teeth	Profile correction
A 17 x 14	14.40	1.6	9	+0.600 <sup>2)</sup>	A 35 x 31	31.50	1.75	18	+0.676
A 20 x 17	19.20	1.6	12	-0.200	A 40 x 36	38.00	1.9	20	+0.049
A 25 x 22	22.40	1.6	14	+0.550	A 45 x 41	44.00	2	22	+0.181
A 28 x 25	26.25	1.75	15	+0.302	A 50 x 45	48.00	2	24	+0.181
A 30 x 27	28.00	1.75	16	+0.327					

#### Basic programme of spline bores acc. to DIN 5480

Spline code	Pitch circle	Module	No. of teeth	Spline code	Pitch circle	Module	No. of teeth
20 x 1 x 18 x 8H	18.0	1	18	40 x 2 x 18 x 8H	36.0	2	18
20 x 1.25 x 14 x 8H	17.5	1.25	14	45 x 2 x 21 x 8H	41.0	2	21
25 x 1.25 x 18 x 8H	22.5	1.25	18	48 x 2 x 22 x 9H	44.0	2	22
28 x 1.25 x 21 x 8H	26.25	1.25	21	50 x 2 x 24 x 8H	48.0	2	24
30 x 2 x 14 x 8H	26.0	2	14	60 x 2 x 28 x 8H	56.0	2	28
32 x 2 x 14 x 8H	28.0	2	14	75 x 3 x 24 x 8H	72.0	3	24
35 x 2 x 16 x 8H	32.0	2	16	80 x 3 x 25 x 8H	75.0	3	25

#### Basic programme of spline bores acc. to DIN 9611 - ISO 500 (p.t.o. shaft connection)

Size	Width of keyway	No. of teeth	Tip circle	Root circle
$1\frac{3}{8}$ "	8.69	6	34.93	29.65
$1\frac{3}{8}$ "	—	21	34.95	34.80 <sup>3)</sup>
$1\frac{3}{4}$ "	11.07	6	44.45	37.74
$1\frac{3}{4}$ "	—	20	45.20	40.20

1 3/8", 6 teeth

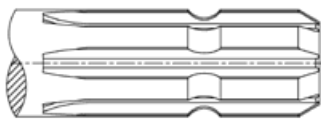

1 3/4", 6 teeth

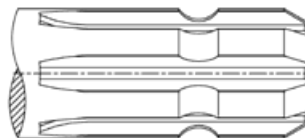

1 3/4", 20 teeth

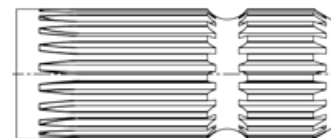

Spline clamping hubs are often adapted to the shafts of hydraulic pump/hydraulic motor shafts. Please contact us for the respective hub length of the spline code!

<sup>1)</sup> For clamping hubs only, with plug-in hubs use code PT or PQ.

<sup>2)</sup> Profile correction different from DIN

<sup>3)</sup> Similar to code PA-S

### Taper bores

#### Basic programme taper 1:8

Code	D <sup>+0.05</sup>	(D2)	B <sup>JS9</sup>	T2 <sup>+0.1</sup>	LK
N/1	9.7	7.575	2.4 <sup>+0.05</sup>	10.85	17.0
N/1c	11.6	9.5375	3 <sup>JS9</sup>	12.90	16.5
N/1e	13.0	10.375	2.4 <sup>+0.05</sup>	13.80	21.0
N/1d	14.0	11.813	3 <sup>JS9</sup>	15.50	17.5
N/1b	14.3	11.8625	3.2 <sup>+0.05</sup>	15.65	19.5
N/2	17.287	14.287	3.2 <sup>+0.05</sup>	18.24	24.0
N/2a	17.287	14.287	4 <sup>JS9</sup>	18.94	24.0
N/2b	17.287	14.287	3 <sup>JS9</sup>	18.34	24.0
N/3	22.002	18.502	4 <sup>JS9</sup>	23.40	28.0
N/4	25.463	20.963	4.78 <sup>+0.05</sup>	27.83	36.0
N/4b	25.463	20.963	5 <sup>JS9</sup>	28.23	36.0
N/4a	27.0	22.9375	4.78 <sup>+0.05</sup>	28.80	32.5
N/4g	28.45	23.6375	6 <sup>JS9</sup>	29.32	38.5
N/5	33.176	27.676	6.38 <sup>+0.05</sup>	35.39	44.0
N/5a	33.176	27.676	7 <sup>JS9</sup>	35.39	44.0

With code N/6 and N/6a keyway in parallel with taper.

#### Basic programme of taper 1:10

Code	D <sup>+0.05</sup>	(D2)	B <sup>JS9</sup>	T2 <sup>+0.1</sup>	LK
CX	19.95	16.75	5 <sup>JS9</sup>	22.08	32
DX	24.95	20.45	6 <sup>JS9</sup>	26.68	45
EX	29.75	24.75	8 <sup>JS9</sup>	31.88	50

#### Basic programme taper 1:5

Code	D <sup>+0.05</sup>	(D2)	B <sup>JS9</sup>	T2 <sup>+0.1</sup>	LK
A-10	9.85	7.55	2 <sup>JS9</sup>	1.0	11.5
B-17	16.85	13.15	3 <sup>JS9</sup>	1.8	18.5
C-20	19.85	15.55	4 <sup>JS9</sup>	2.2	21.5
Cs-22	21.95	17.65	3 <sup>JS9</sup>	1.8	21.5
D-25	24.85	19.55	5 <sup>JS9</sup>	2.9	26.5
E-30	29.85	23.55	6 <sup>JS9</sup>	2.6	31.5
F-35	34.85	27.55	6 <sup>JS9</sup>	2.6	36.5
G-40	39.85	32.85	6 <sup>JS9</sup>	2.6	35.0

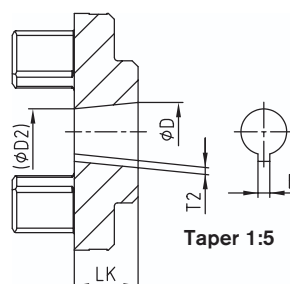

Taper 1:5

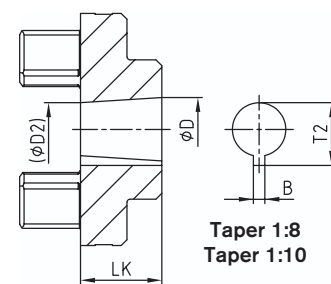

 Taper 1:8  
Taper 1:10

# ROTEX® Standard Flexible jaw couplings

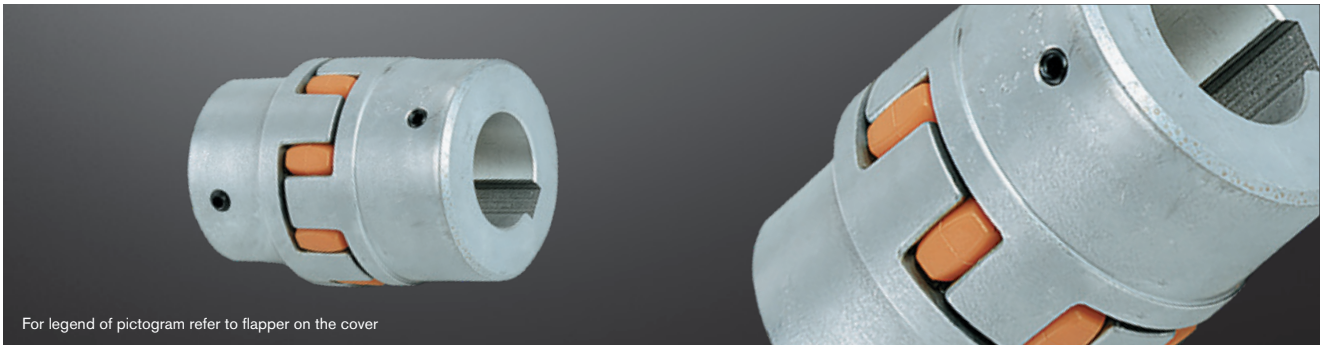
Materials: aluminium + cast + sinter material

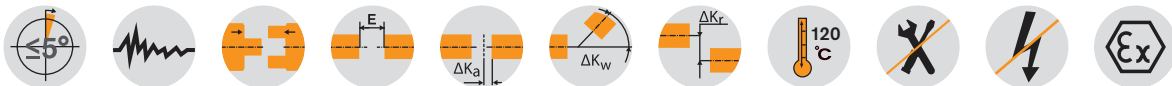

For legend of pictogram refer to flapper on the cover



## ROTEX® Sintered steel (Sint)

Size	Component	Spider <sup>1)</sup> (component 2) Rated torque [Nm]			Finish bore D (min. - max.)	Dimensions [mm]											
		92 ShA	98 ShA	64 ShD		General											
					DH	L	L1, L2	E	S	B1	DI1	DN	N	G	T	TA [Nm]	
14	1a	7.5	12.5	—	0-16	30	35	11	13	1.5	10	10	30	—	M 4	5	1.5
19	1a	10	17	—	0-25	40	66	25	16	2.0	12	18	40	—	M 5	10	2
24	1a	35	60	—	0-35	56	78	30	18	2.0	14	27	56	—	M 5	10	2

## ROTEX® Aluminium diecast (Al-D)

19	1	10	17	—	0-19	41	66	25	16	2	12	18	32	20	M 5	10	2
1a	—	—	—	19-24	41												
24	1	35	60	—	0-24	56	78	30	18	2	14	27	40	24	M 5	10	2
1a	—				22-28								40				
28	1	95	160	—	0-24	66	90	35	20	2.5	15	30	48	28	M 8	15	10
1a	—				24-38								48				
38	1	190	325	—	0-38	114	45	24	18	3.0	80	38	66	36	M 8	15	10
1a	—				25-45								66				

## ROTEX® Aluminium (Al-H)

14	1a	7.5	12.5	16	0-16	30	35	11	13	1.5	10	10.5	—	—	M 4	5	1.5
19	1a	10	17	26	0-24	40	66	25	16	2.0	12	18	—	—	M 5	10	2
24	1a	35	60	75	0-28	55	78	30	18	2.0	14	27	—	—	M 5	10	2
28	1a	95	160	200	0-38	65	90	35	20	2.5	15	30	—	—	M 8	15	10
38	1a	190	325	405	0-45	80	114	45	24	3.0	18	38	—	—	M 8	15	10
42	1a	265	450	560	0-55	95	126	50	26	3.0	20	46	—	—	M 8	20	10
48	1a	310	525	655	0-62	105	140	56	28	3.5	21	51	—	—	M 8	20	10

The coupling is provided with a ROTEX® GS spider as a standard (ROTEX® standard spider available, if requested).

## ROTEX® Cast iron (GJL)

38	1	190	325	405	12-40	80	114	45	24	3	18	38	66	37	M 8	15	10
1a	—				38-48								78				
1b	—				12-48								78				
42	1	265	450	560	14-45	95	126	50	26	3	20	46	75	40	M 8	20	10
1a	—				42-55								94				
1b	—				14-55								94				
48	1	310	525	655	15-52	105	140	56	28	3.5	21	51	85	45	M 8	20	10
1a	—				48-62								104				
1b	—				15-62								104				
55	1	410	685	825	20-60	120	160	65	30	4	22	60	98	52	M 10	20	17
1a	—				55-74								118				
65	1	625	940	1175	22-70	135	185	75	35	4.5	26	68	115	61	M 10	20	17
75	1	1280	1920	2400	30-80	160	210	85	40	5	30	80	135	69	M 10	25	17
90	1	2400	3600	4500	40-100	200	245	100	45	5.5	34	100	160	81	M 12	30	40

## ROTEX® Nodular iron (GJS)

100	1	3300	4950	6185	50-115	225	270	110	50	6	38	113	180	89	M 12	30	40
110	1	4800	7200	9000	60-125	255	295	120	55	6.5	42	127	200	96	M 16	35	80
125	1	6650	10000	12500	60-145	290	340	140	60	7	46	147	230	112	M 16	40	80
140	1	8550	12800	16000	60-160	320	375	155	65	7.5	50	165	255	124	M 20	45	140
160	1	12800	19200	24000	80-185	370	425	175	75	9	57	190	290	140	M 20	50	140
180	1	18650	28000	35000	85-200	420	475	195	85	10.5	64	220	325	156	M 20	50	140

■ = Unless any material is specified in the order, it is defined with the calculation/order.

<sup>1)</sup> Maximum torque of the coupling  $T_{K \max}$  = rated torque of the coupling  $T_{KN} \times 2$ . For selection see page 14 et seqq.

Ordering example:	ROTEX® 38	GJL	92 ShA	1a	Ø45	1	Ø25
		Coupling size	Material	Spider hardness	Component	Finish bore	Component

Components

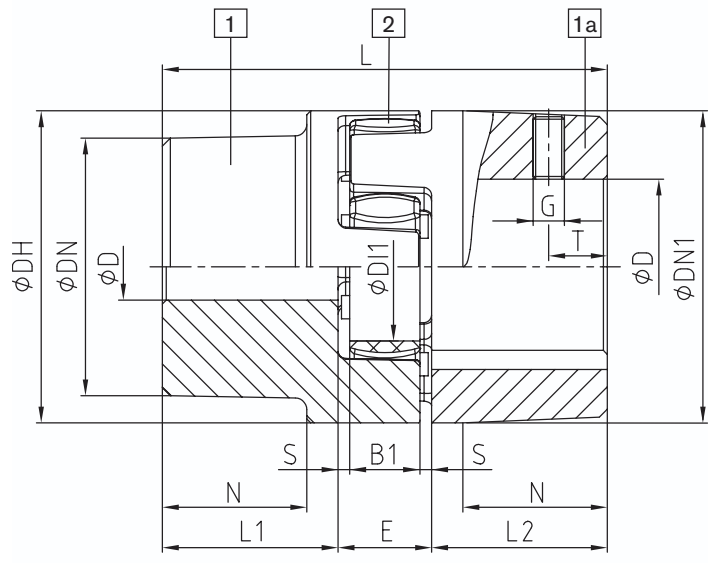

AI-D (thread opposite the keyway)

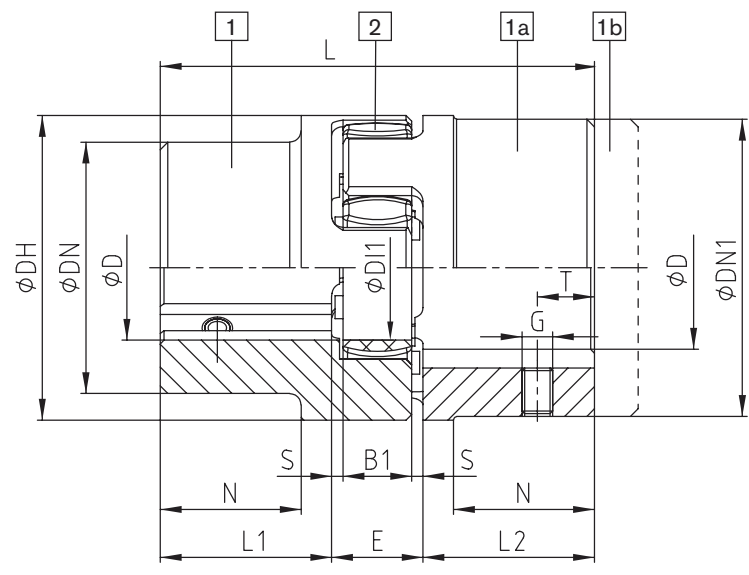

GJL / GJS (thread on the keyway)

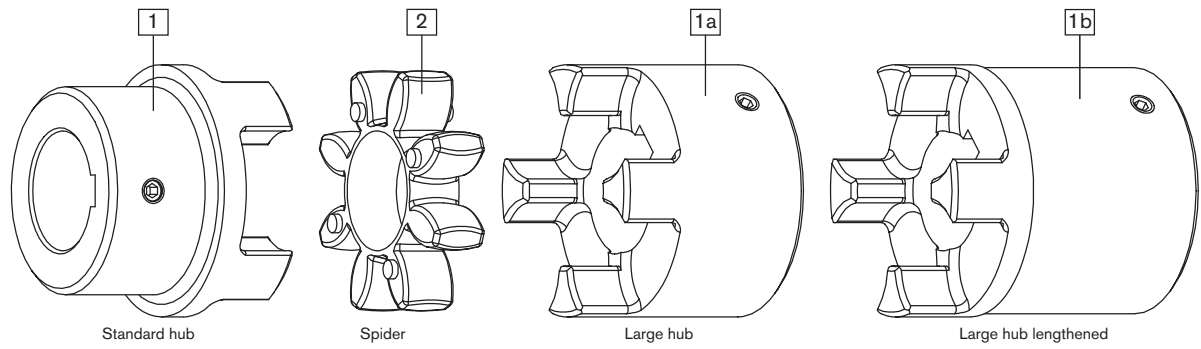

# ROTEX® Standard Flexible jaw couplings

## Material steel/stainless steel

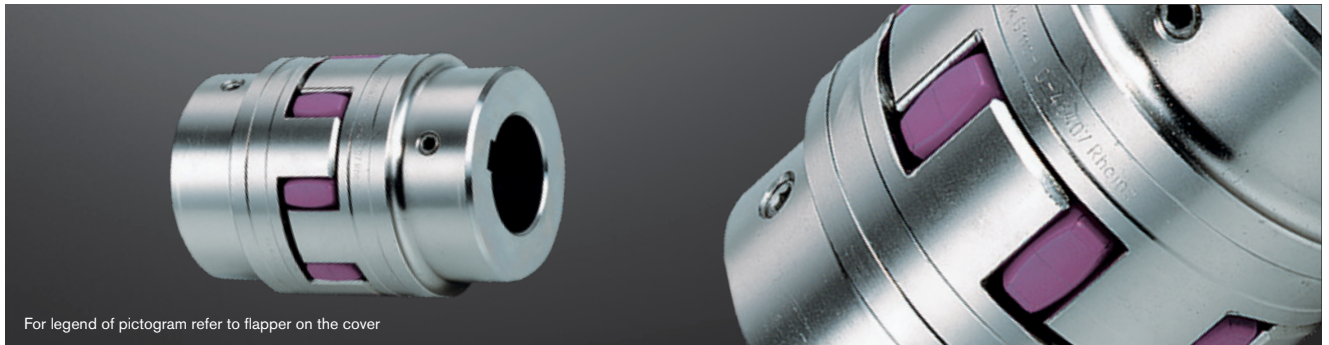

For legend of pictogram refer to flapper on the cover



### ROTEX<sup>®</sup> Steel (St)

Size	Component	Spider <sup>1)</sup> (component 2) Rated torque [Nm]			Finish bore D (min. - max.)	Dimensions [mm]												
		92 ShA	98 ShA	64 ShD		General										Setscrew		
						DH	L	L1, L2	E	S	B1	DI1	DN	N	G	T	TA [Nm]	
14	1a	7.5	12.5	16	0-16	30	35	11	13	1.5	10	10	30	-	M 4	5	1.5	
	1b						50	18.5										
19	1a	10	17	21	0-25	40	66	25	16	2	12	18	40	-	M 5	10	2	
	1b						90	37										
24	1a	35	60	75	0-35	55	78	30	18	2	14	27	55	-	M 5	10	2	
	1b						118	50										
28	1a	95	160	200	0-40	65	90	35	20	2.5	15	30	65	-	M 8	15	10	
	1b						140	60										
38	1	190	325	405	0-48	80	114	45	24	3	18	38	70	27	M 8	15	10	
	1b						164	70					80	-				
42	1	265	450	560	0-55	95	126	50	26	3	20	46	85	28	M 8	20	10	
	1b						176	75					95	-				
48	1	310	525	655	0-62	105	140	56	28	3.5	21	51	95	32	M 8	20	10	
	1b						188	80					105	-				
55	1	410	685	825	0-75	120	160	65	30	4	22	60	110	37	M 10	20	17	
	1b						210	90					120	-				
65	1	625	940	1175	0-80	135	185	75	35	4.5	26	68	115	47	M 10	20	17	
	1b						235	100					135	-				
75	1	1280	1920	2400	0-95	160	210	85	40	5	30	80	135	53	M 10	25	17	
	1b						260	110					160	-				
90	1	2400	3600	4500	0-110	200	245	100	45	5.5	34	100	160	62	M 12	30	40	
	1b						295	125					200	-				
100	1	3300	4950	6185	0-115	225	270	110	50	6	38	113	180	89	M 12	30	40	
110	1	4800	7200	9000	0-130	255	295	120	55	6.5	42	127	200	96	M 16	35	80	
125	1	6650	10000	12500	60-145	290	340	140	60	7	46	147	230	112	M 16	40	80	
140	1	8550	12800	16000	60-160	320	375	155	65	7.5	50	165	255	124	M 20	45	140	
160	1	12800	19200	24000	80-185	370	425	175	75	9	57	190	290	140	M 20	50	140	
180	1	18650	28000	35000	85-200	420	475	195	85	10.5	64	220	325	156	M 20	50	140	

■ = Unless any material is specified in the order, it is defined with the calculation/order.

<sup>1)</sup> Maximum torque of the coupling  $T_{K \max}$  = rated torque of the coupling  $T_{KN} \times 2$ . For selection see page 14 et seqq.

### ROTEX® Stainless steel

Size	Material	Spider (component 2) Rated torque [Nm]			Finish bore D (min. - max.)	Dimensions [mm]												
		92 ShA	98 ShA	64 ShD		General										Setscrew		
						DH	L	L1, L2	E	S	B1	DI1	DN	N	G	T	TA [Nm]	
19	1.4305	10	17	21	0-25	40	66	25	16	2	12	18	40	-	M 5	10	2	
24	1.4305	35	60	75	0-35	55	78	30	18	2	14	27	55	-	M 5	10	2	
28	1.4305	95	160	200	0-40	65	90	35	20	2.5	15	30	65	-	M 8	15	10	
38	1.4305	190	325	405	0-48	80	114	45	24	3	18	38	70	27	M 8	15	10	
42	1.4305	265	450	560	0-55	95	126	50	26	3	20	46	85	28	M 8	20	10	
48	1.4305	310	525	655	0-62	105	140	56	28	3.5	21	51	95	32	M 8	20	10	

Material 1.4571 on request.

Ordering example:	ROTEX® 38	1.4305	92 ShA	1 - Ø45	1 - Ø25
	Coupling size	Material	Spider hardness	Component Finish bore	Component Finish bore

# ROTEX® Flexible jaw couplings

## DIN EN 10204 - 3.1 and 3.2 material test certificate

### Components

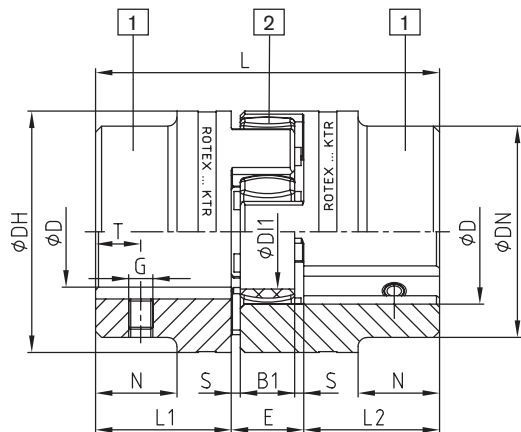

Steel (thread on the keyway)

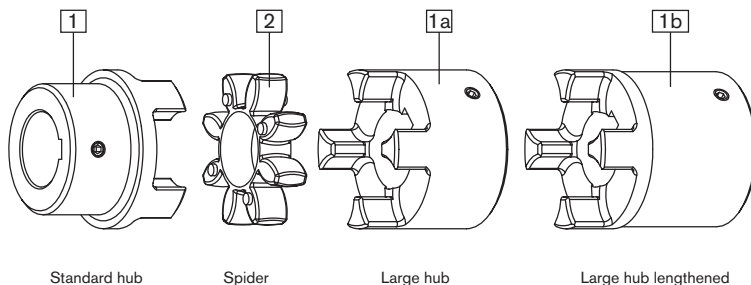

ROTEX® Coupling hubs with test certificate <sup>1)</sup>					
Size	Component	Material <sup>2)</sup>	Inspection certificate acc. to DIN EN 10204		Notch impact strength
19	1a	S355 <sup>2)</sup>	3.1		>=27 J
24	1a	S355 <sup>2)</sup>	3.1		>=27 J
28	1a	S355 <sup>2)</sup>	3.1		>=27 J
38	1a	S355 <sup>2)</sup>	3.1		>=27 J
42	1	S355 <sup>2)</sup>	3.1		>=27 J
48	1	S355 <sup>2)</sup>	3.1		>=27 J
55	1	S355 <sup>2)</sup>	3.1		>=27 J
65	1	S355 <sup>2)</sup>	3.1		>=27 J
75	1	S355 <sup>2)</sup>	3.1/3.2		>=27 J
		42CrMoS4+QT <sup>3)</sup>			
90	1	S355 <sup>2)</sup>	3.1/3.2		>=27 J
		42CrMoS4+QT <sup>3)</sup>			
100	1	S355 <sup>2)</sup>	3.1/3.2		>=27 J
		42CrMoS4+QT <sup>3)</sup>			
110	1	S355 <sup>2)</sup>	3.1/3.2		>=27 J
		42CrMoS4+QT <sup>3)</sup>			
120	1	S355 <sup>2)</sup>	3.1/3.2		>=27 J
		42CrMoS4+QT <sup>3)</sup>			
140	1	S355 <sup>2)</sup>	3.1/3.2		>=27 J
		42CrMoS4+QT <sup>3)</sup>			
160	1	S355 <sup>2)</sup>	3.1/3.2		>=27 J
		42CrMoS4+QT <sup>3)</sup>			
180	1	S355 <sup>2)</sup>	3.1/3.2		>=27 J
		42CrMoS4+QT <sup>3)</sup>			

<sup>1)</sup> S355 suitable for feather key connections, 42CrMoS4+QT for oil press-fits

<sup>2)</sup> Notch impact strength with -40 °C

<sup>3)</sup> Notch impact strength with -20 °C

### Marine programme:

Hub materials S355J2+N and 42CrMo4+QT acc. to DIN EN 10204 - 3.1+3.2, size 75 - 180 available from stock.



## UL



### Use in fire pumps

ROTEX® couplings comply with the specifications of NFPA 20 standards for the installation of stationary pumps for fire protection and due to completion of the endurance tests required they also comply with the specifications of UL 448A, flexible couplings and connection shafts for stationary fire pumps.

Sizes available:



ROTEX® UL Listed									
Size	Component	Material	Spider (component 2) Rated torque [Nm] 92 ShA	Dimensions [mm]					
				Finish bore D (min. - max.)	DH	L	L1; L2	E	
42	1	St	265	18-55	95	126	50	26	
55	1	St	410	24-74	120	160	65	30	
65	1	St	625	24-80	135	185	75	35	
75	1	St	1280	24-95	160	210	85	40	
90	1	St	2400	30-110	200	245	100	45	

\* for complete dimensions see table on page 40

# ROTEX® Flexible jaw couplings

## Taper clamping sleeve

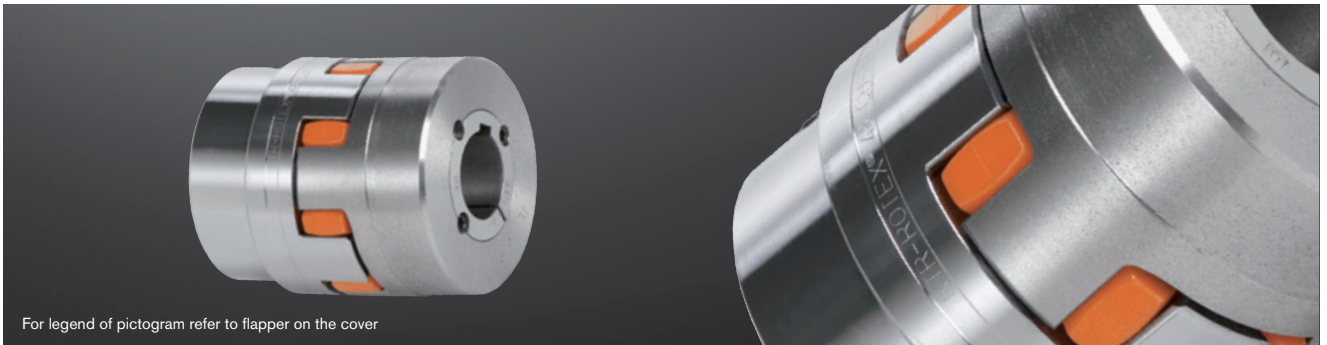

For legend of pictogram refer to flapper on the cover



### Components

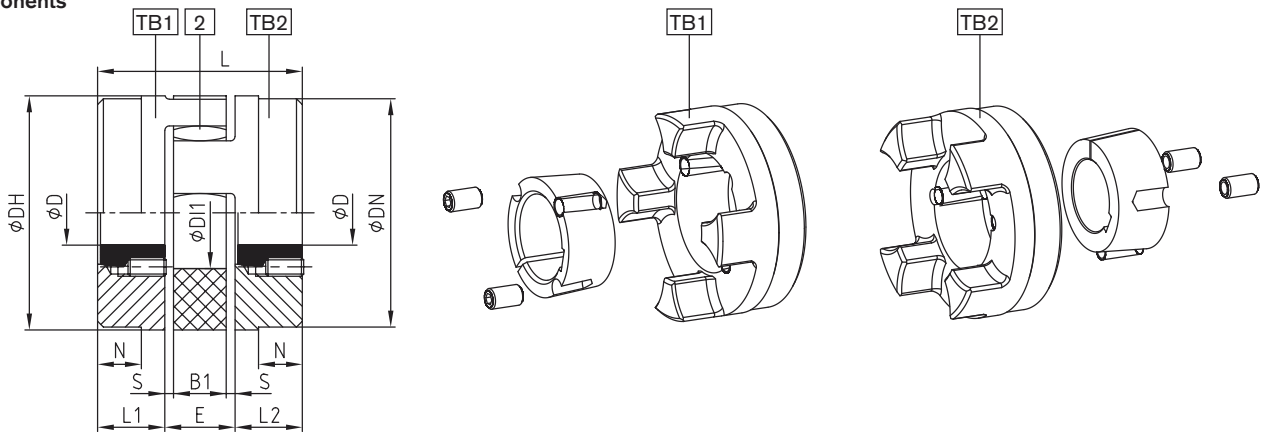

### ROTEX® shaft coupling for taper clamping sleeve

Size	Taper clamping sleeve	Spider <sup>1)</sup> (component 2) Rated torque [Nm]			Dimensions [mm]						Fastening screws for taper clamping sleeve			
		92 ShA	98 ShA	64 ShD	DH	L	L1, L2	E	S	Size [inch] <sup>2)</sup>	Length [mm]	Number	T <sub>A</sub> [Nm]	
24	1008	35	60	75	55	62	22	18	2.0	1/4"	13	2	5.7	
28	1108	95	160	200	65	66	23	20	2.5	1/4"	13	2	5.7	
38	1108	190	325	405	80	70	23	24	3.0	1/4"	13	2	5.7	
42	1610	265	450	560	95	78	26	26	3.0	3/8"	16	2	20	
48	1615	310	525	655	105	106	39	28	3.5	3/8"	16	2	20	
55	2012	410	685	825	120	96	33	30	4.0	7/16"	22	2	31	
65	2012	625	940	1175	135	101	33	35	4.5	7/16"	22	2	31	
75	2517	1280	1920	2400	160	144	52	40	5.0	1/2"	25	2	49	
	5/8"									32	92			
90	3020	2400	3600	4500	200	149	52	45	5.5	5/8"	32	2	92	
100	3535	3300	4950	6185	225	230	90	50	6.0	1/2"	49	3	113	
125	4545	6650	10000	12500	290	288	114	60	7.0	3/4"	49	3	192	

### Taper clamping sleeve

Size	Summary of bore dimensions D [mm], H7 fit - feather keyway acc. to DIN 6885 sheet 1																		
1008	Ø10	Ø11	Ø12	Ø14	Ø16	Ø18	Ø19	Ø20	Ø22	Ø24	Ø25								
1108	Ø10	Ø11	Ø12	Ø14	Ø16	Ø18	Ø19	Ø20	Ø22	Ø24	Ø25	Ø28 <sup>3)</sup>							
1610	Ø14	Ø16	Ø18	Ø19	Ø20	Ø22	Ø24	Ø25	Ø28	Ø30	Ø32	Ø35	Ø38	Ø40	Ø42 <sup>3)</sup>				
1615	Ø14	Ø16	Ø18	Ø19	Ø20	Ø22	Ø24	Ø25	Ø28	Ø30	Ø32	Ø35	Ø38	Ø40	Ø42 <sup>3)</sup>				
2012	Ø14	Ø16	Ø18	Ø19	Ø20	Ø22	Ø24	Ø25	Ø28	Ø30	Ø32	Ø35	Ø38	Ø40	Ø42	Ø45	Ø48	Ø50	
2517	Ø16	Ø18	Ø19	Ø20	Ø22	Ø24	Ø25	Ø28	Ø30	Ø32	Ø35	Ø38	Ø40	Ø42	Ø45	Ø48	Ø50	Ø55	Ø60
3020	Ø25	Ø28	Ø30	Ø35	Ø38	Ø40	Ø42	Ø45	Ø48	Ø50	Ø55	Ø60	Ø65	Ø70	Ø75				
3535	Ø35	Ø38	Ø40	Ø42	Ø45	Ø48	Ø50	Ø55	Ø60	Ø65	Ø70	Ø75	Ø80	Ø85	Ø90				
4545	Ø55	Ø60	Ø65	Ø70	Ø75	Ø80	Ø85	Ø90	Ø95	Ø100	Ø105	Ø110							

• Available for type TB2 only

<sup>1)</sup> Maximum torque of the coupling T<sub>K max</sub> = rated torque of the coupling T<sub>KN</sub> x 2. For selection see page 14 et seqq.

<sup>2)</sup> 1. BSW thread

**Coupling type TB1/TB2, TB1/TB1 and TB2/TB2 possible.**

Please order our separate dimension sheet (M373054).

<sup>3)</sup> Bores with feather keyway (flat design) acc. to DIN 6885 sheet 3

Ordering example:	ROTEX® 38	92 ShA	1108	TB1 - Ø24		TB2 - Ø22	
	Coupling size	Spider hardness	Taper clamping sleeve	Hub type	Finish bore	Hub type	Finish bore

## Clamping ring hubs



For legend of pictogram refer to flapper on the cover

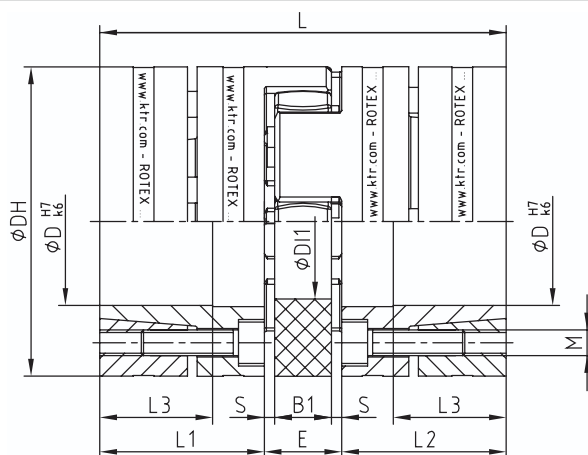

Extraction thread M1 between clamping screws.

### Clamping ring hubs steel

Size	Spider <sup>1)</sup> Rated torque [Nm]			Dimensions [mm]							Clamping screws				Weight per hub with max. bore [kg]	Mass moment of inertia per hub with max. bore [kgm <sup>2</sup> ]		
	92 ShA	98 ShA	64 ShD	TKN	TK max	TKN	DH <sup>2)</sup>	L	L1, L2	E	S	E	M	Z = number			T <sub>A</sub> [Nm]	M 1
	TKN	TK max	TKN															
19	10.0	17	21	40	18	66	25	18	16	M 4	6	4.1	M 4	0.179	0.44 x 10 <sup>-4</sup>			
24	35.0	60	75	55	27	78	30	22	18	M 5	4	8.5	M 5	0.399	1.91 x 10 <sup>-4</sup>			
28	95.0	160	200	65	30	90	35	27	20	M 5	8	8.5	M 5	0.592	4.18 x 10 <sup>-4</sup>			
38	190.0	325	405	80	38	114	45	35	24	M 6	8	14	M 6	1.225	12.9 x 10 <sup>-4</sup>			
42	265	450	560	95	46	126	50	35	26	M 8	4	41	M 8	2.30	31.7 x 10 <sup>-4</sup>			
48	310	525	655	105	51	140	56	41	28	M 10	4	69	M 10	3.08	52.0 x 10 <sup>-4</sup>			
55	375	685	825	120	60	160	65	45	30	M 10	4	69	M 10	4.67	103.0 x 10 <sup>-4</sup>			
65	—	940	1175	135	68	185	75	55	35	M 12	4	120	M 12	6.70	191.0 x 10 <sup>-4</sup>			
75	—	1920	2400	160	80	210	85	63	40	M 12	5	120	M 12	9.90	396.8 x 10 <sup>-4</sup>			
90	—	3600	4500	200	104	245	100	75	45	M 16	5	295	M 16	17.70	1136 x 10 <sup>-4</sup>			

### Bore D and the respective transmittable friction torques T<sub>R</sub> of clamping ring hub in [Nm] <sup>1)</sup>

Size	Ø10	Ø11	Ø14	Ø15	Ø16	Ø19	Ø20	Ø24	Ø25	Ø28	Ø30	Ø32	Ø35	Ø38	Ø40	Ø42	Ø45	Ø48	Ø50	Ø55*	Ø60*	Ø65*	Ø70*	Ø80*	Ø90*	Ø95*	Ø100*	Ø105*	
19	27	32	69	84	57	94	110																						
24			70	87	56	97	114	116	133	192																			
28				108	131	207	148	253	285	315	382	330	433	503															
38							208	353	395	439	531	463	603	593	689	793	776												
42									445	495	595	526	678	671	775	718	872	1043	1061										
48										616	704	899	896	1030	962	1160	1379	1222	1543										
55													863	856	991	918	1119	1110	1247	1277	1665	1605	2008						
65															1446	1355	1637	1635	1827	1887	2429	2368	2930						
75																1710	2053	2059	2294	2384	3040	2983	3664	4293					
90																				3845	4249	4794	5858	5900	7036	8047	9247	9575	10845

<sup>1)</sup> For selection see page 14 et seqq.

<sup>2)</sup> ØDH + 2 mm with high speeds for expansion of spider The transmittable torques of the clamping connection consider the max. clearance with shaft clearance k6/bore H7, from Ø55 G7/m6. The torque is reduced with bigger clearance. For the strength calculation of shaft/hollow shaft see KTR standard 45510 on our homepage www.ktr.com.

Ordering example:	ROTEX® GS 24	98 ShA	6.0 steel	Ø24	6.0 steel	Ø20
	Coupling size	Spider hardness	Hub type	Finish bore	Hub type	Finish bore

# ROTEX® Flexible jaw couplings

## Clamping hubs



For legend of pictogram refer to flapper on the cover

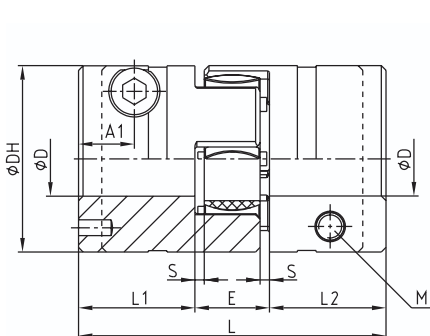

ROTEX® 19 - 28

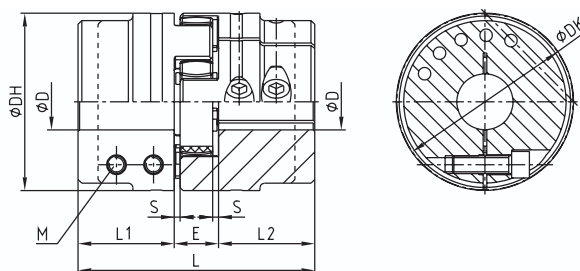

ROTEX® 38 - 90

### ROTEX® as clamping hubs

Size	Spider <sup>1)</sup> Rated torque [Nm]			Dimensions [mm]							Screw DIN EN ISO 4762	
	92 ShA	98 ShA	64 ShD	Max. finish bore D	DH	DK	L	L1; L2	E	S	M	T <sub>A</sub> [Nm]
19	10	17	21	20 <sup>2)</sup>	40	46.0	66	25	16	2.0	M 6	14
24	35	60	75	28	55	57.5	78	30	18	2.0	M 6	14
28	95	160	200	38	65	73.0	90	35	20	2.5	M 8	35
38	190	325	405	42	80	77.5	114	45	24	3.0	M 8	35
42	265	450	560	50	95	93.5	126	50	26	3.0	M 10	69
48	310	525	655	55	105	105.0	140	56	28	3.5	M 12	120
55	410	685	825	68	120	119.5	160	65	30	4.0	M 12	120
65	625	940	1175	70	135	132.5	185	75	35	4.5	M 12	120
75	1280	1920	2400	80	160	158.0	210	85	40	5.0	M 16	295
90	2400	3600	4500	90	200	197.0	245	100	45	5.5	M 20	580

### Bore D and the respective transmittable friction torques T<sub>R</sub> [Nm] of ROTEX® clamping hubs type 2.0

Size	Ø8	Ø10	Ø11	Ø14	Ø15	Ø16	Ø18	Ø19	Ø20	Ø22	Ø24	Ø25	Ø28	Ø30	Ø32	Ø35	Ø38	Ø40	Ø42	Ø45	Ø48	Ø50	Ø55	Ø60	Ø65	Ø70	Ø75	Ø80	Ø85	Ø90	
19	44	46	47	51	52	53	55	57	58																						
24		59	60	64	65	66	68	70	71	73	76	77	80																		
28				139	141	144	148	150	152	157	161	163	170	174	178	185	191														
38					163	165	170	172	174	178	183	185	192	196	200	207	213	217	222												
42									291	297	304	308	318	325	332	342	353	360	367	377	387	394									
48									466	476	486	491	506	516	526	542	557	567	577	592	607	618	643								
55															1185	1215	1245	1266	1286	1316	1347	1367	1417	1468	1519						
65																1316	1347	1367	1387	1417	1448	1468	1519	1569	1620	1671					
75																		2869	2926	2983	3022	3117	3213	3309	3404	3500	3595				
90																				5220	5310	5400	5460	5610	5760	5910	6060	6210	6360	6510	6660

<sup>1)</sup> Maximum torque of the coupling T<sub>K max</sub> = rated torque of the coupling T<sub>KN</sub> x 2. For selection see page 14 et seqq.

<sup>2)</sup> With type 2.1 D<sub>max</sub>. Ø17 mm



**Type 2.0**  
Clamping hub single slot  
without feather keyway



**Type 2.1**  
Clamping hub single slot with  
feather keyway



**Type 2.3**  
Clamping hub with spline  
bore (For a selection of our  
programme of spline bores see  
page 37)

Ordering  
example:

ROTEX® 24	98 ShA	2.1	Ø24	2.0	Ø20
Coupling size	Spider hardness	Hub type	Finish bore	Hub type	Finish bore

# ROTEX® AFN and BFN Flexible jaw couplings

## Flange programme

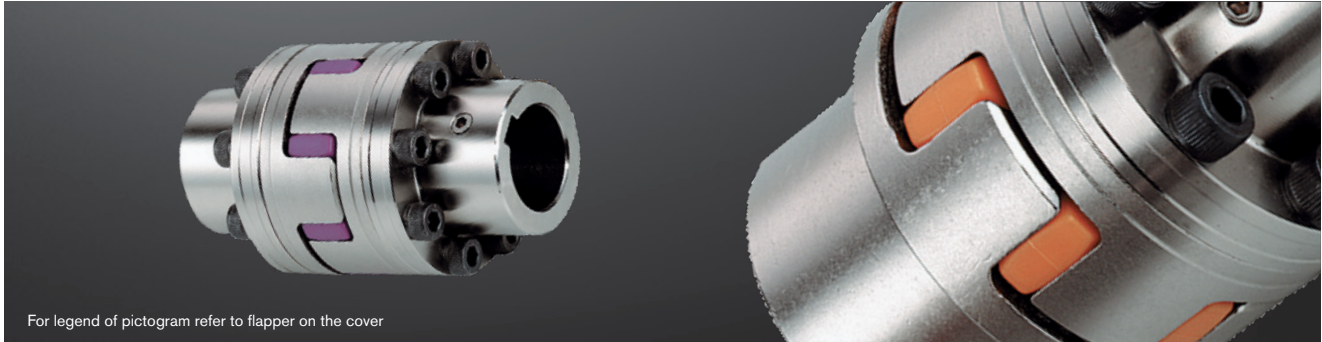

For legend of pictogram refer to flapper on the cover

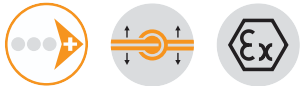

### Components

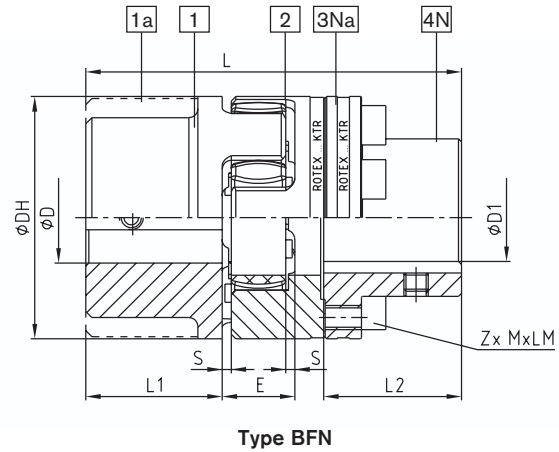
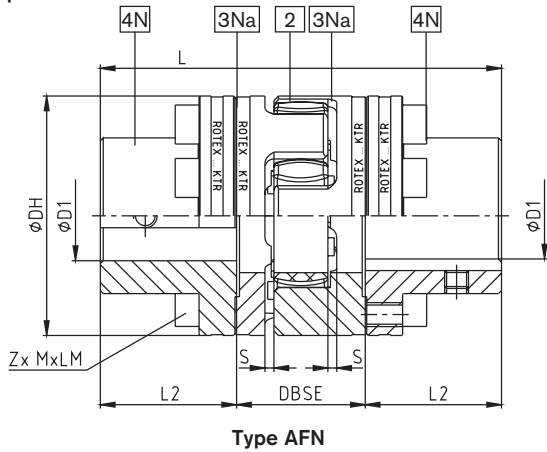

ROTEX® Type AFN and BFN																
Size	Spider <sup>1)</sup> Rated torque [Nm]			Finish bore		Dimensions in mm							Cap screws <sup>3)</sup> DIN EN ISO 4762 - 12.9			
	92 ShA	98 ShA	64 ShD	D (max.)	D1 (max.)	DH	DBSE	L1, L2	E	S	L		MxLM	Z	T <sub>A</sub> <sup>2)</sup> [Nm]	
											AFN	BFN				
24	35.0	60	75	35	24	55	33	30.5	18	2.0	94	86	M5x16	8	10	
28	95.0	160	200	40	28	65	39	35.5	20	2.5	110	100	M6x20	8	17	
38	190.0	325	405	48	38	80	43	45.5	24	3.0	134	124	M8x22	8	41	
42	265	450	560	55	44	95	48	51.0	26	3.0	150	138	M8x25	12	41	
48	310	525	655	62	50	105	50	57.0	28	3.5	164	152	M8x25	12	41	
55	375	685	825	75	60	120	60	66.0	30	4.0	192	176	M10x30	8	83	
65	410	940	1175	80	70	135	65	76.0	35	4.5	217	201	M10x30	12	83	
75	625	1920	2400	95	80	160	75	86.5	40	5.0	248	229	M12x40	15	120	
90	1280	3600	4500	110	105	200	82	101.5	45	5.5	285	265	M16x40	15	295	
100	2400	3600	4500	115	115	225	97	111.5	50	6.0	320	295	M16x50	15	295	
110	3300	4950	6185	125	130	255	103	122.0	55	6.5	347	321	M20x50	15	580	
125	6650	10000	12500	145	150	290	116	142.0	60	7.0	400	370	M20x60	15	580	
140	8550	12800	16000	160	170	320	128	157.5	65	7.5	443	409	M20x60	15	580	
160	12800	19200	24000	185	200	370	146	177.5	75	9.0	501	463	M24x70	15	1000	
180	18650	28000	35000	200	230	420	159	198.0	85	10.5	555	515	M24x80	18	1000	

<sup>1)</sup> Maximum torque of the coupling  $T_{K \max}$  = rated torque of the coupling  $T_{KN} \times 2$ . For selection see page 14 et seqq.

<sup>2)</sup> Screw tightening torque  $T_A$  [Nm].

<sup>3)</sup> Coupling is delivered not assembled.

Ordering example:	ROTEX® 24	AFN	92 ShA	4N	Ø38	4N	Ø35
	Coupling size	Type	Spider hardness	Component	Finish bore	Component	Finish bore

ROTEX® Flexible jaw and pin & bush couplings  
 ROFLEX®  
 POLY-NORM®  
 POLY-NORM®-M  
 REVOLEX®

# ROTEX® AH

## Flexible jaw couplings

### Drop-out center design coupling

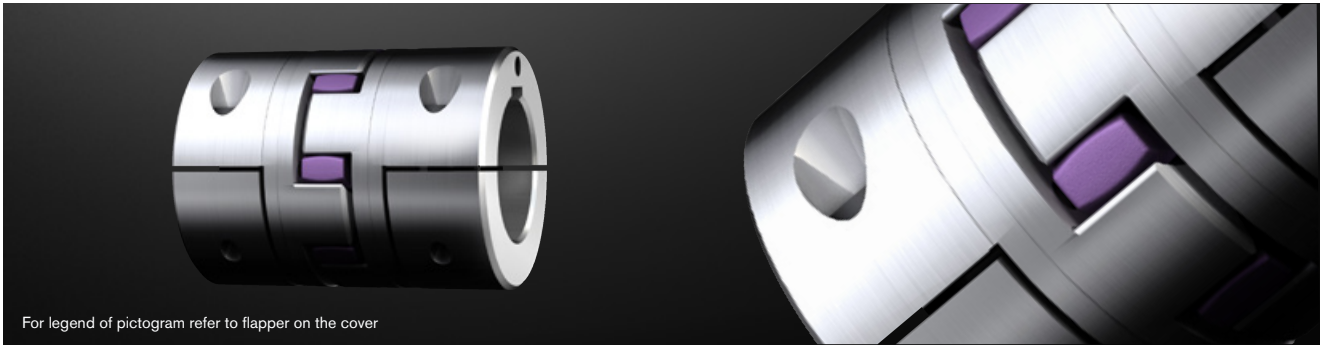

For legend of pictogram refer to flapper on the cover

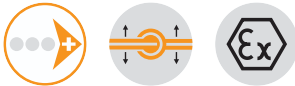

#### Components

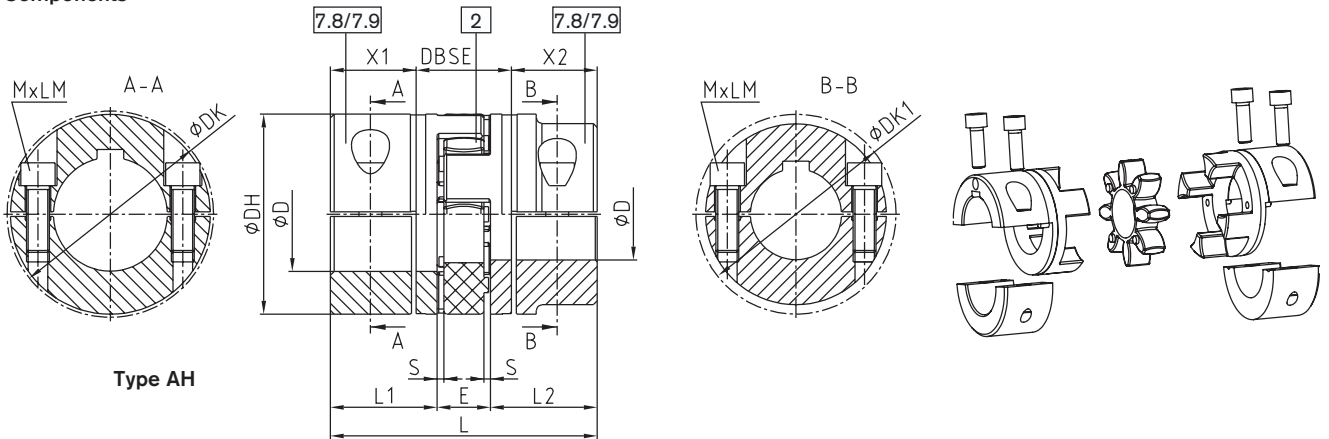

ROTEX® Type AH																
Size	Spider <sup>1)</sup>			Dimensions [mm]										Cap screws DIN EN ISO 4762		
	92 ShA	98 ShA	64 ShD	Finish bore D (max.)	DH	L	L1, L2	E	S	DK	DK1	X1, X2	DBSE	MxLM	Tightening torque T <sub>A</sub> [Nm]	
19	10	17	21	20	40	66	25	16	2.0	46.0	—	17.5	31	M6x16	14	
24	35	60	75	28	55	78	30	18	2.0	57.5	—	22.5	33	M6x20	14	
28	95	160	200	38	65	90	35	20	2.5	73.0	—	25.5	39	M8x25	35	
38	190	325	405	45	80	114	45	24	3.0	83.5	—	35.5	43	M8x30	35	
42	265	450	560	50	95	126	50	26	3.0	—	93.5	39.0	48	M10x30	69	
				55						—	105.0			M10x35		
48	310	525	655	55	105	140	56	28	3.5	—	108.5	45.0	50	M12x35	120	
				60						—	119.5			M12x40		
55	410	685	825	65	120	160	65	30	4.0	—	122.0	50.0	60	M12x45	120	
				70						—	123.5			M12x40		
65	625	940	1175	70	135	185	75	35	4.5	—	132.5	60.0	65	M12x45	120	
				80						—	147.5			M16x50		
75	1280	1920	2400	80	160	210	85	40	5.0	—	158.0	67.5	75	M16x50	295	
				90						—	176.0			M20x60		
90	2400	3600	4500	90	200	245	100	45	5.5	—	197.0	81.5	82	M20x60	580	
				110						—	185.5			M16x50		
100 <sup>2)</sup>	3300	4950	6185	110	225	270	110	50	6.0	—	208.0	84.0	102	M16x50	295	
110 <sup>2)</sup>	4800	7200	9000	120	255	295	120	55	6.5	—	208.0	90.0	115	M20x60	580	
125 <sup>2)</sup>	6650	10000	12500	140	290	340	140	60	7.0	—	242.5	105.0	130	M24x70	1000	

#### CAUTION:

With maximum bore the feather keyways are offset to each other by approx. 5°  
Hub material up to size 90: steel, from size 100: GJS

7.8 = Half shell clamping hub without feather keyway max. circumferential speed of  $v = 35$  m/s.

From a circumferential speed of  $v = 25$  m/s dynamic balancing is necessary; from a circumferential speed of  $v = 25$  m/s the frictional torque of shaft/hub has to be reviewed. Please consult with KTR.

7.9 = Half shell clamping hub with feather keyway max. circumferential speed of  $v = 35$  m/s. From a circumferential speed of  $v = 25$  m/s dynamic balancing is required.

Speed: max. circumferential speed of 25 m/s on the outside diameter DH of the coupling

<sup>1)</sup> Maximum torque of the coupling  $T_{K \max} =$  rated torque of the coupling  $T_{KN} \times 2$ . For selection see page 14 et seqq.

<sup>2)</sup> from size 100: 4-off clamping screws per clamping hub

Ordering example:	ROTEX® 38	AH	98 ShA	7.9	Ø38	7.9	Ø30
	Coupling size	Type	Spider hardness	Hub type	Finish bore	Hub type	Finish bore



### Drop-out center design coupling with SPLIT hubs

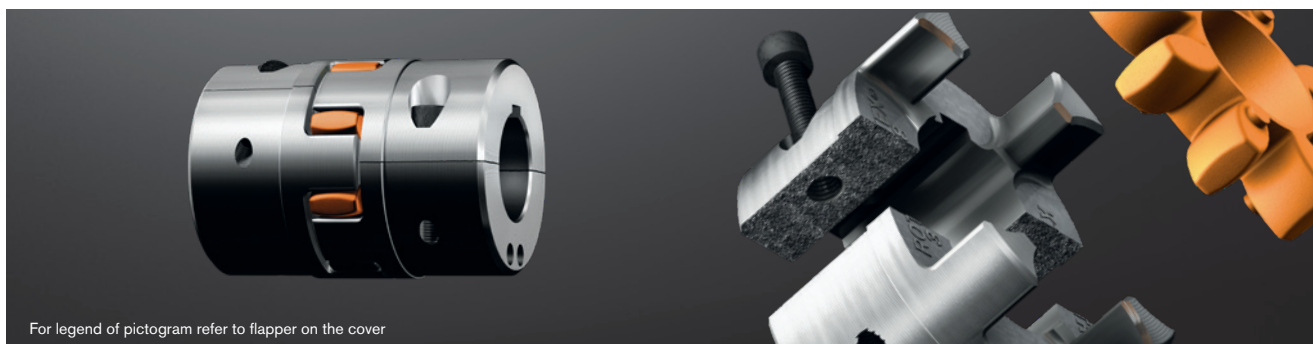

For legend of pictogram refer to flapper on the cover



#### Components

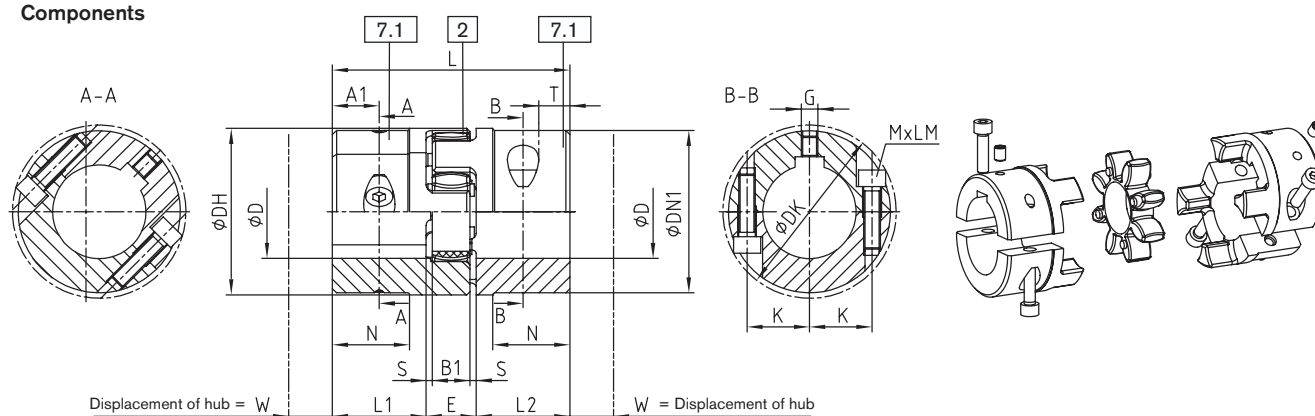

Type SH

ROTEX® Type SH Sintered steel (Sinter)												
Size	Spider <sup>1)</sup> Rated torque [Nm]		Dimensions [mm]								Cap screws DIN EN ISO 4762	
	92 ShA	98 ShA	Finish bore D (min. - max.)	DH	L	L1, L2	E	S	DK	W	MxLM	Tightening torque T <sub>A</sub> [Nm]
19	10	17	0-24	40	66	25	16	2.0	44	-	M4x14	4.1
24	35	60	0-28	55	78	30	18	2.0	57.5	12	M6x20	14
28	95	160	0-38	65	90	35	20	2.5	73	12	M8x25	34

ROTEX® Type SH Cast iron (GJL)												
Size	Spider <sup>1)</sup> Rated torque [Nm]		Dimensions [mm]								Cap screws DIN EN ISO 4762	
	92 ShA	98 ShA	Finish bore D (min. - max.)	DH	L	L1, L2	E	S	DK	W	MxLM	Tightening torque T <sub>A</sub> [Nm]
38	190	325	24-48	80	114	45	24	3.0	83.5	15	M8x30	34
42	265	450	24-55	95	126	50	26	3.0	97	15	M10x35	67
48	310	525	24-60	105	140	56	28	3.5	108.5	15	M12x40	115
55	410	685	24-70	120	160	65	30	4.0	122	15	M12x45	115
65	625	940	28-70	135	185	75	35	4.5	123.5	15	M12x40	115
			70-80						132.5			
75	1280	1920	40-80	160	210	85	40	5.0	147	20	M16x50	290
			80-90						158			
90	2400	3800	40-90	200	245	100	45	5.5	176	30	M20x60	560
			90-110						197			
100	3300	4950	50 - 100	225	270	110	50	6	199.5	44	M20x70	580
110	4800	7200	50 - 120	255	295	120	55	6.5	224	48.5	M24x80	1000

ROTEX® type SH steel (St) - on request -													
Size	Spider <sup>1)</sup> Rated torque [Nm]			Dimensions [mm]								Cap screws DIN EN ISO 4762	
	92 ShA	98 ShA	64 ShD	Finish bore D (min. - max.)	DH	L	L1, L2	E	S	DK	W	MxLM	Tightening torque T <sub>A</sub> [Nm]
125	6650	10000	12500	60 - 145	230	340	140	60	7	249	53	M24x90	1000
140	8550	12800	16000	60 - 160	255	375	155	65	7.5	276	57.5	M24x110	1000
160	12800	19200	24000	80 - 180	290	425	175	75	9	313	66	M27x120	1500
180	18650	28000	35000	85 - 200	420	475	195	85	10.5	349	74.5	M27x140	1500

7.1 = SPLIT hub with feather keyway

<sup>1)</sup> Maximum torque of the coupling T<sub>K max</sub> = rated torque of the coupling T<sub>KN</sub> x 2. For selection see catalogue Drive Technology.

Available from stock

Ordering example:	ROTEX® 38	SH	98 ShA	7.1	Ø38	7.1	Ø30
	Coupling size	Type	Spider hardness	Hub type	Finish bore	Hub type	Finish bore

# ROTEX® CF, CFN, DF and DFN Flexible jaw couplings

## Flange programme

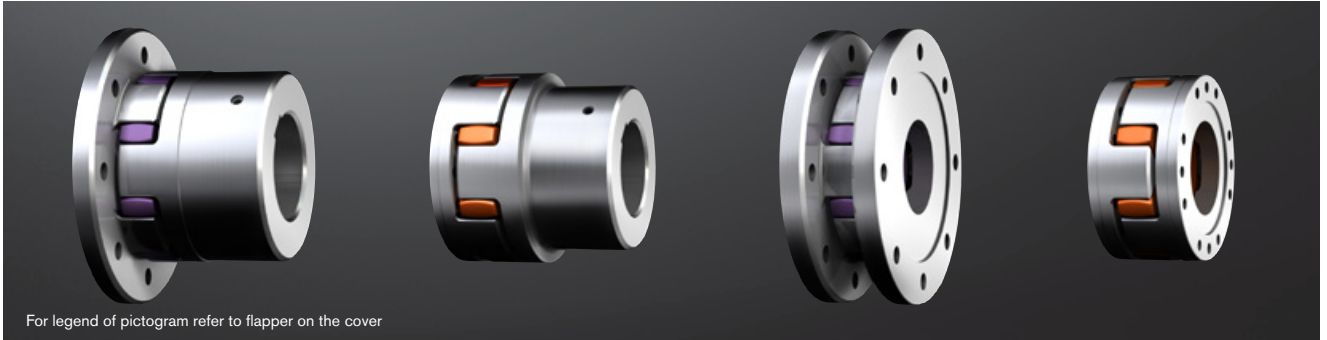

For legend of pictogram refer to flapper on the cover



### Components

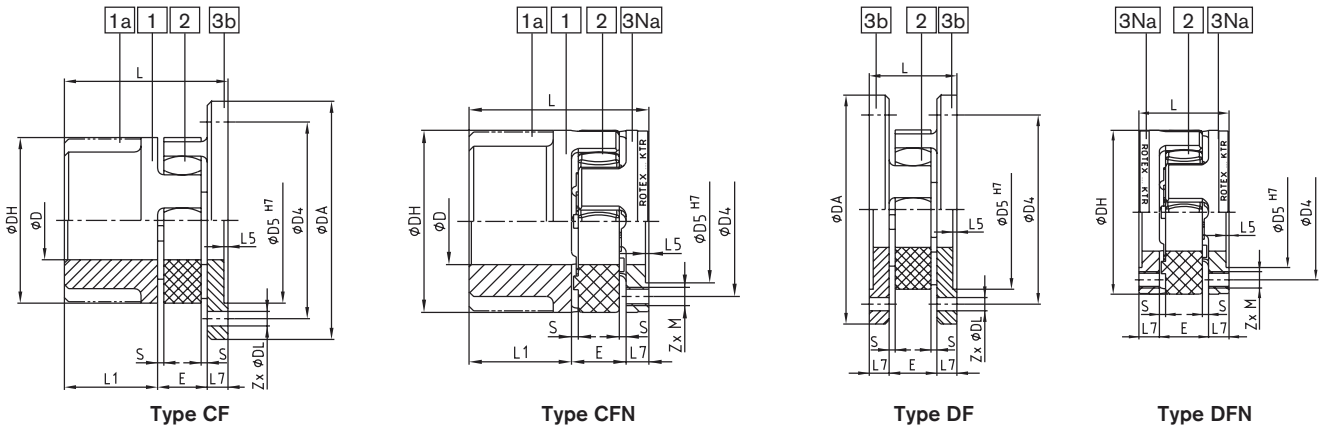

ROTEX® Type CF, CFN and DF, DFN																							
Size	Spider <sup>1)</sup> Rated torque [Nm]			Dimensions [mm]																			
	92 ShA	98 ShA	64 ShD	DH	L1	E	S	L5	L7	CF and DF						CFN and DFN							
	DA	D4	D5							Z	DL	LCF	LDF	D4	D5	M	Z	pitch	LCFN	LDFN			
24	35	60	75	55	30	18	2.0	1.5	8	80	65	55	5	4.5	56	34	45	36	M 5	8		56	34
28	95	160	200	65	35	20	2.5	1.5	10	100	80	65	6	6.6	65	40	54	44	M 6	8	8x45°	65	40
38	190	325	405	80	45	24	3.0	1.5	10	115	95	80	6	6.6	79	44	66	54	M 8	8		79	44
42	265	450	560	95	50	26	3.0	2.0	12	140	115	95	6	9.0	88	50	80	65	M 8	12	16x22.5°	88	50
48	310	525	655	105	56	28	3.5	2.0	12	150	125	105	8	9.0	96	52	90	75	M 8	12		96	52
55	410	685	825	120	65	30	4.0	2.0	16	175	145	120	8	11.0	111	62	102	84	M 10	8	8x45°	111	62
65	625	940	1175	135	75	35	4.5	2.0	16	190	160	135	10	11.0	126	67	116	96	M 10	12	16x22.5°	126	67
75	1280	1920	2400	160	85	40	5.0	2.5	19	215	185	160	10	13.5	144	78	136	112	M 12	15		144	78
90	2400	3600	4500	200	100	45	5.5	3.0	20	260	225	200	12	13.5	165	85	172	145	M 16	15		165	85
100	3300	4950	6185	225	110	50	6.0	4.0	25	285	250	225	12	13.5	185	100	195	165	M 16	15		185	100
110	4800	7200	9000	255	120	55	6.5	4.0	26	330	290	255	12	17.5	201	107	218	180	M 20	15	20x18°	201	107
125	6650	10000	12500	290	140	60	7.0	5.0	30	370	325	290	16	17.5	230	120	252	215	M 20	15		230	120
140	8550	12800	16000	320	155	65	7.5	5.0	34	410	360	320	16	22.0	254	133	282	245	M 20	15		254	133
160	12800	19200	24000	370	175	75	9.0	5.0	38	460	410	370	16	22.0	288	151	325	280	M 24	15		288	151
180	18650	28000	35000	420	195	85	10.5	5.5	40	520	465	420	16	26.0	320	165	375	330	M 24	18	24x15°	320	165

<sup>1)</sup> Maximum torque of the coupling  $T_{K \max}$  = rated torque of the coupling  $T_{KN} \times 2$ . For selection see page 14 et seqq.  
For other flange programmes see page 45.

Other types: ROTEX® CF-H  
Flange drop-out center design coupling  
Please order our separate dimension sheet  
(M412069).

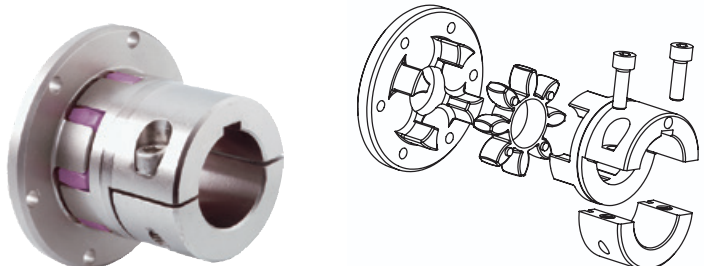

Ordering example:	ROTEX® 38	CF	92 ShA	1	GJL	Ø20
	Coupling size	Type	Spider hardness	Hub side, component	Material	Finish bore

# ROTEX® ZS-DKM-SH

## Flexible jaw couplings

### Double-cardanic shaft coupling with SPLIT hubs

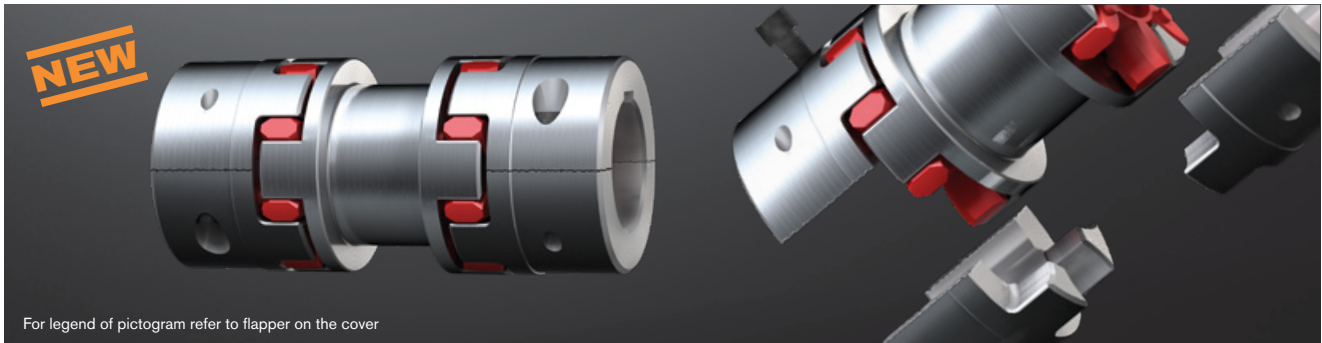

For legend of pictogram refer to flapper on the cover

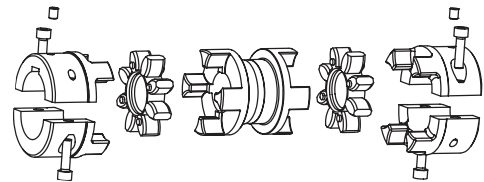
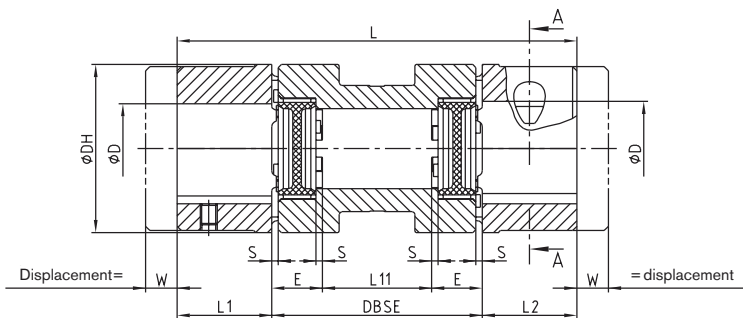

ROTEX® type ZS-DKM-SH																				
Size <sup>3)</sup>	Spider ROTEX GS T <sub>KN</sub> [Nm] <sup>1) 2)</sup>	Drop-out center design length DBSE	Dimensions [mm]										Screws DIN EN ISO 4762		Max. displacements					
			Finish bore D		DH	L1, L2	L11	E	S	L	W	DK	M	T <sub>A</sub> [Nm]	Axial [mm]	with n = 1500 rpm			with n = 3000 rpm	
			min.	max.												Radial [mm]	Angular [°]	Radial [mm]	Angular [°]	
19	12	42 <sup>5)</sup>	0	24	40	25	16	16	2.0	92	-	-	-	-	1.2	0.45	-	-	-	-
		52 <sup>5)</sup>					112			0.59						-	-			
24	35	100	0	28	55	30	64	18	2.0	160	12	57.5	M 6	14	1.4	1.43	-	1.07	-	-
		140					200			2.13						-	1.60			
		58 <sup>5)</sup>					128			0.66						-	-			
28	95	100	0	38	65	35	60	20	2.5	170	12	73	M 8	34	1.5	1.40	-	1.05	-	-
		140					210			2.10						-	1.57			
		68 <sup>5)</sup>					158			0.77						-	-			
38	190	100	24	45	80	45	52	24	3.0	190	15	83.5	M 8	34	1.8	1.33	-	0.99	-	-
		140					230			2.02						-	1.52			
		74 <sup>5)</sup>					174			0.84						-	-			
42	265	100	24	55	95	50	48	26	3.0	200	15	97	M 10	67	2.0	1.29	-	0.97	-	-
		140					240			2.00						-	1.49			
		80 <sup>5)</sup>					192			0.91						-	-			
48	310	100	24	60	105	56	44	28	3.5	212	15	108.5	M 12	115	2.1	1.26	-	0.94	-	-
		140					252			1.95						1	1.47			
		88 <sup>5)</sup>					218			1.01						-	0.75			
55	410	100	24	70	120	65	40	30	4.0	230	15	122	M 12	115	2.2	1.22	-	0.92	-	-
		140					270			1.92						-	1.44			
		180					310			2.62						-	1.96			
65	625	100	24	80	135	75	32	35	4.5	252	15	132.5 <sup>6)</sup>	M 12	115	2.6	1.17	-	2.22	-	-
		140					290			1.83						-	1.37			
		180					330			2.53						-	1.90			
75	1280	116 <sup>5)</sup>	40	90	160	85	36	40	5.0	286	20	158 <sup>6)</sup>	M 16	290	3.0	1.33	-	-	-	-
		140					310			1.75						-	1.31			
		180					350			2.44						-	1.83			
90	2400	200	40	110	200	100	120	45	5.5	370	30	197 <sup>6)</sup>	M 20	560	3.4	2.79	-	2.09	-	-
		250					420			3.67						-	2.75			
		130 <sup>5)</sup>					330			1.48						-	-			
		180					90			380						2.36	-	1.76	-	-
		250					160			450						3.58	-	2.68	-	-

<sup>1)</sup> Maximum torque of coupling T<sub>K max</sub> = rated torque of coupling T<sub>KN</sub> x 2  
<sup>2)</sup> Mathematically transmittable torque with double-cardanic types acc. to 92 ShA-GS using the higher quality spiders 98 ShA-GS  
<sup>3)</sup> ROTEX®-SPLIT hub material sizes 24 and 28 = sintered steel; hub material sizes 38 to 90 = EN-GJL  
<sup>4)</sup> Hub type 7.1 = SPLIT hub with feather keyway and thread for setscrews  
<sup>5)</sup> Material spacer Al-H  
<sup>6)</sup> ØDN and ØDK depending on finish bore ØD, see page 36/37

The max. permissible circumferential speed for double-cardanic ROTEX® DKM and ZS-DKM-SH couplings is 20m/s, with higher speeds please consult with KTR. Spiders ROTEX® 98 ShA-GS and 64 ShD-GS applicable, while the transmittable torque [T<sub>KN</sub>; T<sub>Kmax</sub>] of the 92 ShA-GS spider must not be exceeded.

Ordering example:	ROTEX® 38	ZS-DKM-SH	140	98 ShA-GS	7.1 <sup>4)</sup>	Ø 38	7.1 <sup>4)</sup>	Ø30
		Coupling size	Type	Shaft distance dimension DBSE	Spider hardness	Hub type	Finish bore	Hub type

# ROTEX® ZRS

## Flexible /backlash-free intermediate shaft coupling

### Intermediate shaft programme

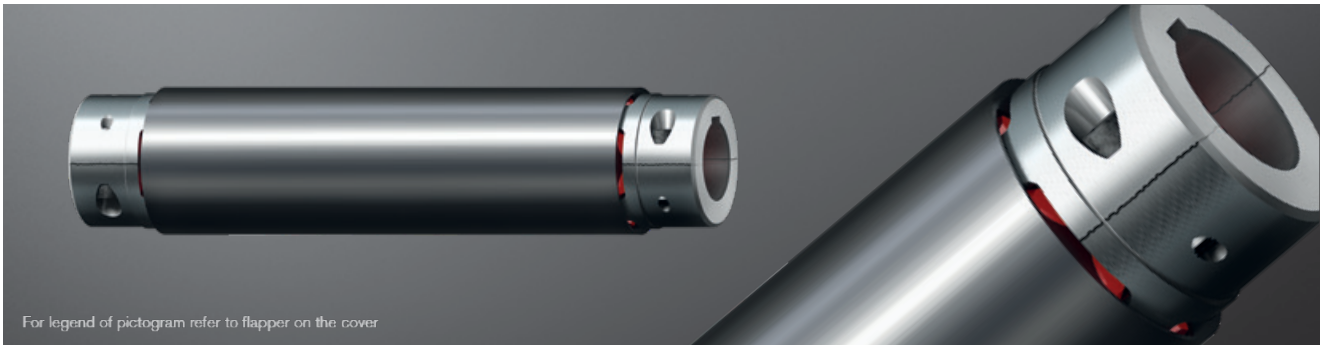

For legend of pictogram refer to flapper on the cover

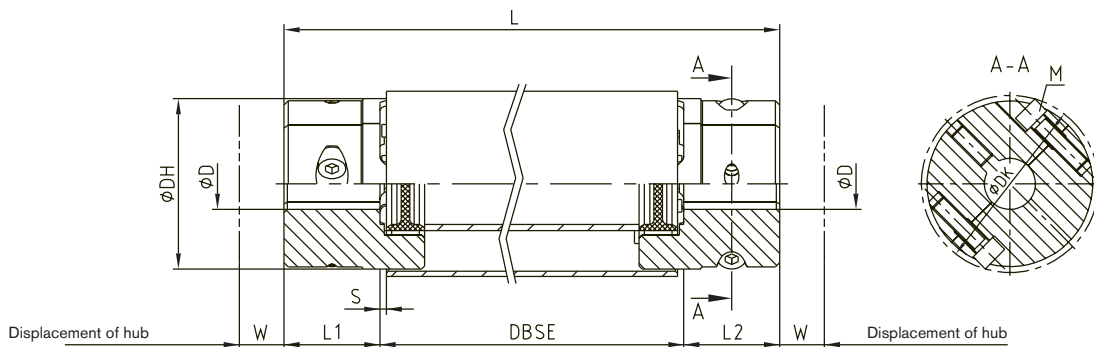

ROTEX® type ZRS																		
Size	Spider ROTEX GS T <sub>KN</sub> [Nm] <small>1) 2)</small>	Finish bore D <sup>3)</sup>		Dimensions [mm]												Clamping screw DIN EN ISO 4762		Intermediate pipe Torsion spring stiffness C <sup>5)</sup> [Nm/rad]
		min.	max.	DH	L <sup>1)</sup>	L1, L2	E	S	DK	DH1	min. DBSE <sup>4)</sup>	W	DK	M	Tightening torque T <sub>A</sub> [Nm]			
19	12	0	20	40	L = DBSE + L1 + L2	25	16	2.0	46.0	45	33	14.0	46.0	M 4	4.1	3800		
24	35	0	24	55		30	18	2.0	57.5	60	37	16.0	57.5	M 6	14	11100		
28	95	0	38	65		35	20	2.5	73.0	72	40	17.5	73.0	M 8	34	23600		
38	190	24	45	80		45	24	3.0	83.5	87	49	21.0	83.5	M 8	34	43800		
42	265	24	55	95	50	26	3.0	97.0	103	53	23.0	97.0	M 10	67	82600			

- <sup>1)</sup> Maximum torque of coupling T<sub>K max</sub> = rated torque of coupling T<sub>KN</sub> x 2
- <sup>2)</sup> Mathematically transmittable torque with double-cardanic types acc. to 92 ShA-GS using the higher quality spiders 98 ShA-GS
- <sup>3)</sup> Finish bore according to ISO fit H7, feather keyway according to DIN 6885, sheet 1 [JS9]
- <sup>4)</sup> With inquiries and orders please specify the shaft distance dimension DBSE along with the maximum speed to review the critical bending speed.  
Maximum DBSE = 4000 mm (different lengths on request).
- <sup>5)</sup> Torsion spring stiffness with an intermediate pipe length of 1 m

Diagramme for coupling selection:

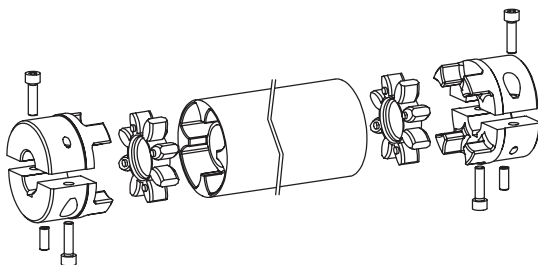
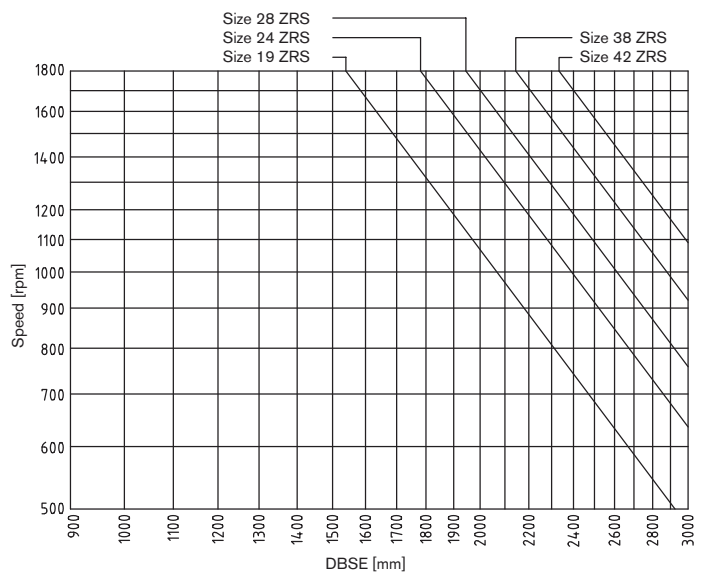

7.1 = SPLIT hub with feather keyway

Displacements			
Size	Axial displacement in mm	Radial displacement [mm] per 1m of pipe length	Angular displacement in degree
19	1.2	15.7	0.9
24	1.4	15.7	0.9
28	1.5	15.7	0.9
38	1.8	17.5	1.0
42	2.0	17.5	1.0

Ordering example:	ROTEX® 38	ZRS	1200	98 ShA-GS	7.1	Ø30	7.1	Ø30
	Coupling size	Type	Shaft distance dimension DBSE	Spider hardness	Hub type	Finish bore	Hub type	Finish bore

# ROTEX® ZR

## Flexible jaw couplings

### Intermediate shaft programme

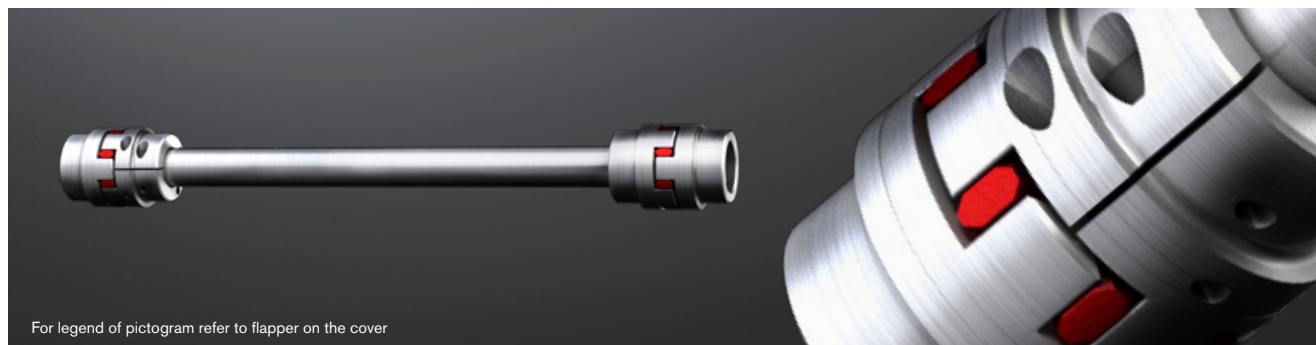

For legend of pictogram refer to flapper on the cover

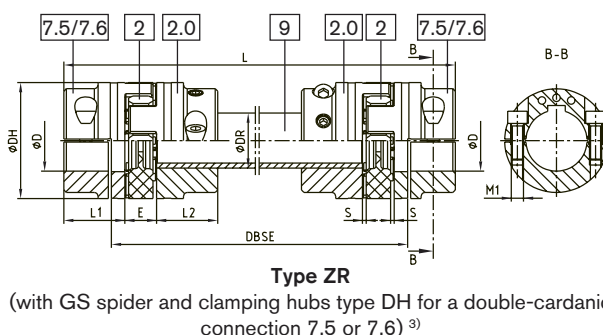
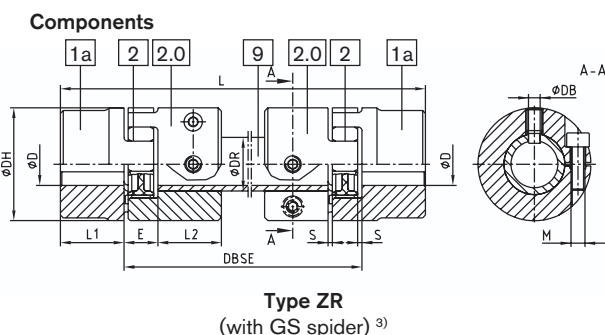

ROTEX® Type ZR																				
Size	Spider ROTEX GS T <sub>KN</sub> [Nm] <sup>1)2)</sup>	Dimensions [mm]							Screw DIN EN ISO 4762						Intermediate tube					
		Finish bore D min. - max.)		DH	L		L1, L2	E	S	Min. DBSE <sup>3)</sup>		Component 2.0		Component 7.5/7.6		Fastening screw G	Pin hole DB in mm	DR [mm]	Torsional stiffness C <sup>4)</sup> [Nm <sup>2</sup> /rad]	
		Component 1a	Component 7.5/7.6		Component 1/1a	Component 7.5/7.6				Component 1a	Component 7.5/7.6	DK1	M	T <sub>A</sub> [Nm]	DK					M 1
19	12	0-25	0-20	40	35+DBSE	25	16	2.0	82	97	46.0	M 6	14	46.0	M 6	10	M 6	4.0	Ø20x3	954.9
24	35	0-35	0-28	55	45+DBSE	30	18	2.0	96	111	59.5	M 6	14	57.5	M 6	14	M 8	5.5	Ø30x4	4522
28	95	0-40	0-38	65	51+DBSE	35	20	2.5	110	128	73.0	M 8	35	73.0	M 8	35	M 10	7.0	Ø35x4	7611
38	190	0-48	24-45	80	71+DBSE	45	24	3.0	138	157	81.6	M 8	25	83.5	M 8	35	M 12	8.5	Ø40x4	11870
42	265	0-55	24-55	95	78+DBSE	50	26	3.0	152	174	95.0	M 10	49	97.0	M 10	69	M 12	8.5	Ø45x4	17487
48	310	0-62	24-60	105	90+DBSE	56	28	3.5	168	190	105.0	M 12	86	108.5	M 12	120	M 16	12	Ø50x4	24648
55	410	0-74	24-70	120	100+DBSE	65	30	4.0	190	220	120.0	M 12	120	120.0	M 12	120	M 16	12	Ø55x4	33544
65	625	0-80	24-80	135	120+DBSE	75	35	4.5	220	250	135.0	M 12	120	135.0	M 12	120	M 16	12	Ø65x5	68329
75	1280	0-95	40-90	160	135+DBSE	85	40	4.0	250	285	160.0	M 16	295	160.0	M 16	295	M 16	12	Ø75x5	108000

- <sup>1)</sup> Maximum torque of coupling T<sub>K max</sub> = rated torque of coupling T<sub>KN</sub> x 2  
<sup>2)</sup> Mathematically transmittable torque with double-cardanic types acc. to 92 ShA-GS using the higher quality spiders 98 ShA-GS  
<sup>3)</sup> With inquiries and orders please specify the shaft distance dimension DBSE along with the maximum speed to review the critical bending speed.  
<sup>4)</sup> Torsion spring stiffness with 1 m length of intermediate pipe finish bore acc. to ISO fit H7, feather keyway acc. to DIN 6885 sheet 1 [JS9]. Friction torques of clamping hubs have to be considered. Please order dimension sheet M583613.

Not permissible for crane and hoist drives

Displacements			
Size	Axial displacement in mm	Radial displacement in [mm] per 1m of pipe length	Angular displacement in degree
19	1.2	15.9	0.9
24	1.4	15.9	0.9
28	1.5	15.9	0.9
38	1.8	17.9	1.0
42	2.0	17.9	1.0
48	2.1	19.7	1.1
55	2.2	19.7	1.1
65	2.6	21.7	1.2
75	3.0	21.7	1.2

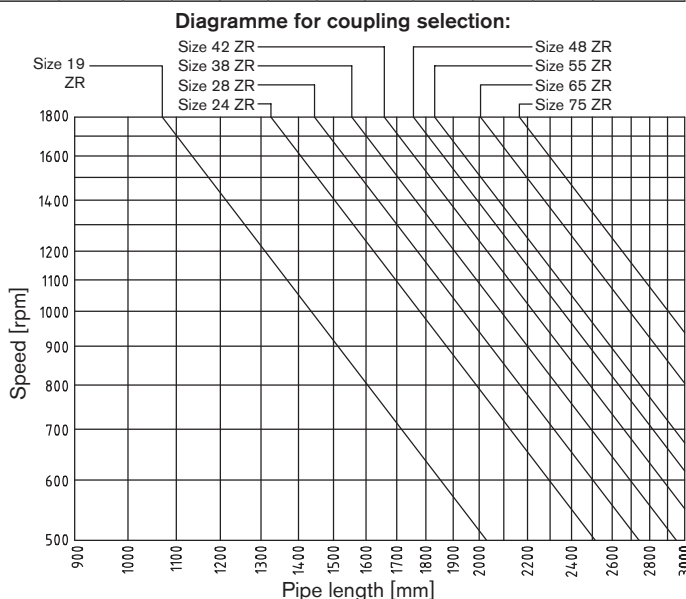

Ordering example:	ROTEX® 38	ZR	1200	98 ShA-GS	7.5	Ø38	7.5	Ø30
	Coupling size	Type	Shaft distance dimension DBSE	Spider hardness	Hub type	Finish bore	Hub type	Finish bore

# ROTEX® BTAN and SBAN Flexible jaw couplings

With brake drum/with brake disk

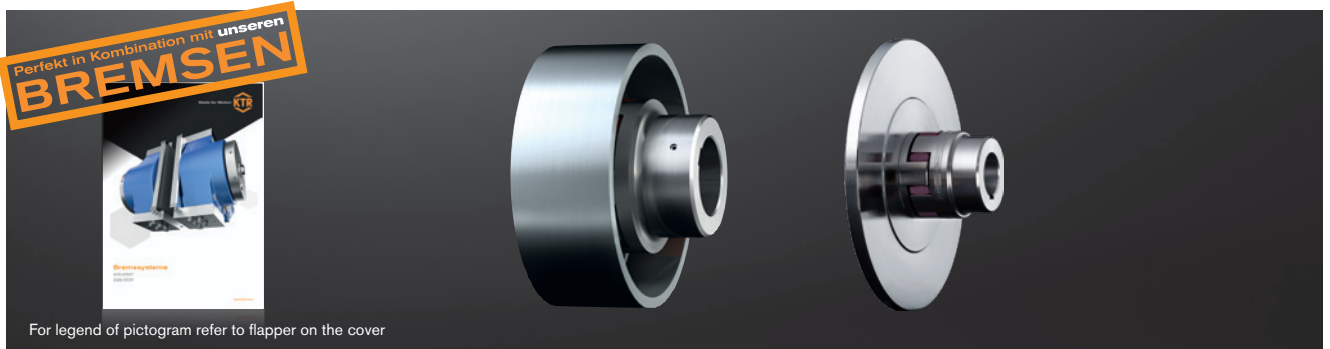

## Components

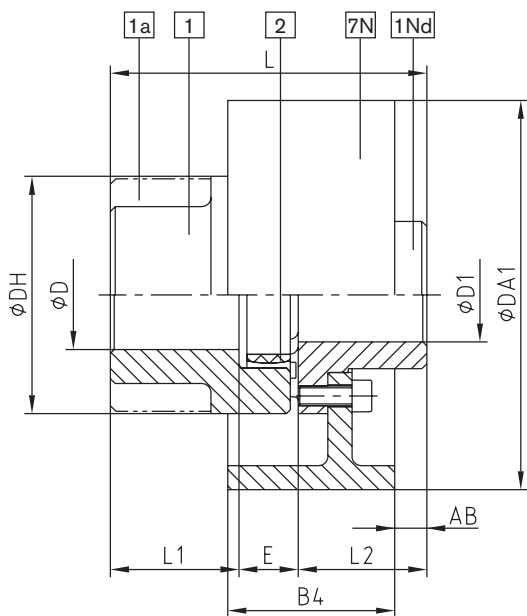

**Brake drum  
Type BTAN**

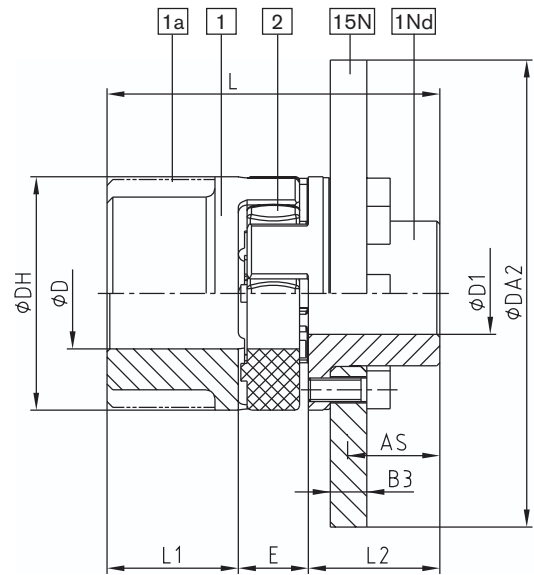

**Brake disk  
Type SBAN**

ROTEX® Type BTAN and SBAN										
Size	Spider <sup>1)</sup> Rated torque [Nm]			Dimensions [mm]						
	92 ShA	98 ShA	64 ShD	max. finish bore D1 (min. - max.) <sup>2)</sup>		DH	L	L1, L2	E	S
				Component 1	Component 1Nd					
38	190	325	405	0 - 48	0 - 35	80	114	45	24	3.0
42	265	450	560	0 - 55	0 - 42	95	126	50	26	3.0
48	310	525	655	0 - 63	0 - 48	105	140	56	28	3.5
55	410	685	825	0 - 75	0 - 55	120	160	65	30	4.0
65	625	940	1175	0 - 80	0 - 68	135	185	75	35	4.5
75	1280	1920	2400	0 - 95	0 - 78	160	210	85	40	5.0
90	2400	3600	4500	0 - 110	0 - 104	200	245	100	45	5.5
100	3300	4950	6185	0 - 115	48 - 100	225	270	110	50	6.0
110	4800	7200	9000	0 - 130	60 - 110	255	295	120	55	6.5
125	6650	10000	12500	0 - 145	60 - 130	290	340	140	60	7.0

<sup>1)</sup> Maximum torque of the coupling  $T_{K \max}$  = rated torque of the coupling  $T_{KN}$  x 2. For selection see page 14 et seqq.

<sup>2)</sup> Finish bore according to ISO fit H7, feather keyway according to DIN 6885, sheet 1 [JS9].

<b>Ordering example:</b>	ROTEX® 38	BTAN	Ø200x75	98 ShA	1Nd	Ø34	1	Ø30
	Coupling size	Type	Brake drum Ø x width	Spider hardness	Component	Finish bore	Component	Finish bore

Type BTAN brake drum							Type SBAN brake disk						
ROTEX® size	Dimensions [mm]			Speed [rpm]	Weight [kg]	Mass moment of inertia [kgm²]	ROTEX® size	Dimensions [mm]			Speed [rpm]	Weight [kg]	Mass moment of inertia [kgm²]
	DA1	B4	AB					DA1	B4	AB			
38	160	60	14	3550	2.9	0.01	38	200	12.5	31.25	2800	2.9	0.01
	200	75	9	2800	5.4	0.04		250	12.5	31.25	2240	4.6	0.04
	250	95	1	2240	10.4	0.12	42	250	12.5	34.25	2240	4.5	0.04
42	200	75	12	2800	5.3	0.04		315	16	32.5	1800	9.3	0.12
	250	95	4	2240	10.3	0.01	48	250	12.5	39.25	2240	4.4	0.04
	315	118	-5	1800	19.3	0.36		315	16	37.5	1800	9.2	0.12
48	400	150	-18	1400	40.6	1.21	55	400	16	37.5	1400	15.2	0.32
	200	75	17	2800	5.3	0.04		315	16	44.5	1800	9.1	0.12
	250	95	9	2240	9.4	0.11	65	400	16	44.5	1400	13.9	0.29
	315	118	0	1800	17.8	0.33		500	16	44.5	1120	23.9	0.77
55	400	150	-13	1400	37.4	1.11	75	315	16	53.5	1800	8.8	0.12
	200	75	24	2800	4.8	0.04		400	16	53.5	1400	14.8	0.31
	250	95	16	2240	9.3	0.11	90	500	16	53.5	1120	23.7	0.77
65	315	118	7	1800	17.7	0.33		630	20	51.5	900	47.7	2.43
	400	150	-6	1400	37.2	1.12	710	20	51.5	800	60.9	3.92	
	250	95	25	2240	9.2	0.11	100	315	16	61.5	1800	8.4	0.12
75	315	118	16	1800	17.5	0.33		400	16	61.5	1400	14.4	0.31
	400	150	3	1400	36.9	1.12	110	500	16	61.5	1120	23.3	0.77
	500	190	-12	1120	77.7	3.64		630	20	59.5	900	47.2	2.42
90	250	95	33	2240	9.1	0.13	125	710	20	59.5	800	60.4	3.91
	315	118	24	1800	17.1	0.33		400	16	73.5	1400	13.4	0.31
	400	150	11	1400	31.4	0.94	150	500	16	73.5	1120	22.2	0.76
100	500	190	-4	1120	76.8	3.62		630	20	71.5	900	45.9	2.42
	630	236	-22	900	143.6	10.65	200	710	20	71.5	800	59.1	3.91
	315	118	36	1800	16.3	0.33		800	25	69.0	710	94.9	7.88
110	400	150	23	1400	38.4	1.20	250	400	16	81.5	1400	12.9	0.31
	500	190	8	1120	62.9	3.07		500	16	81.5	1120	21.8	0.76
	630	236	-10	900	142.8	10.74	300	630	20	79.5	900	45.3	2.41
125	400	150	31	1400	37.9	1.20		710	20	79.5	800	58.5	3.90
	500	190	16	1120	75.2	3.63	350	800	25	77.0	710	94.1	7.87
	630	236	-2	900	141.2	10.64		400	16	88.5	1400	11.9	0.29
150	710	265	-13	800	210.2	20.01	400	500	16	88.5	1120	20.8	0.75
	400	150	38	1400	34.0	1.09		630	20	86.5	900	44.1	2.40
	500	190	23	1120	73.9	3.62	450	710	20	86.5	800	57.3	3.89
200	630	236	5	900	141.1	10.77		800	25	84.0	710	92.7	7.86
	710	265	-6	800	192.5	18.46	500	900	25	84.0	630	118.9	12.61
	500	190	39	1120	72.4	3.60		500	16	104.5	1120	19.7	0.74
250	630	236	21	900	127.7	9.82	600	630	20	102.5	900	42.8	2.39
	710	265	10	800	190.7	18.44		710	20	102.5	800	56.0	3.87
	800	300	-4	710	274.5	33.34	700	800	25	100.0	710	91.0	7.84
						900		25	100.0	630	117.2	12.59	

# ROTEX® AFN-SB special Flexible jaw couplings

## Drop-out center design coupling with brake disk

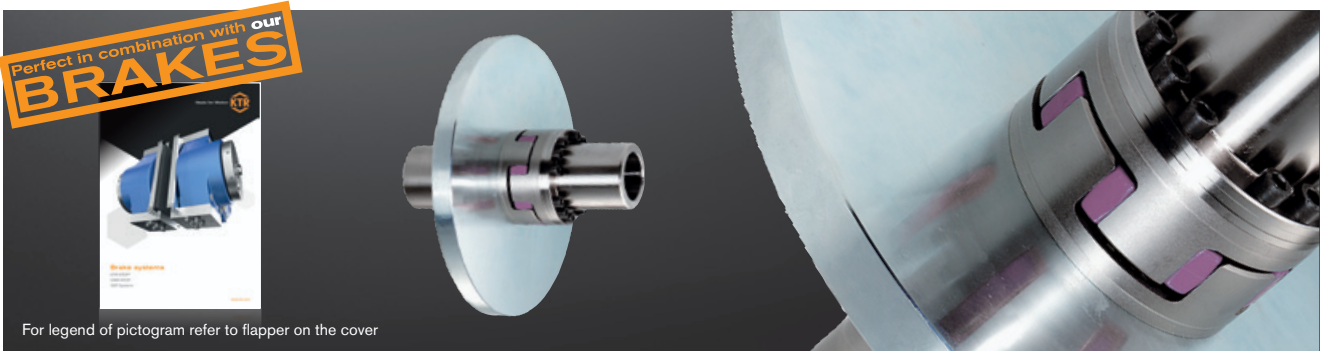

### Components

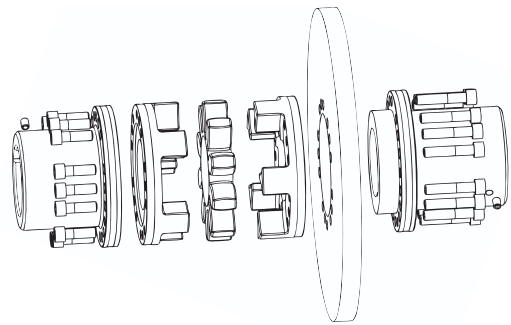
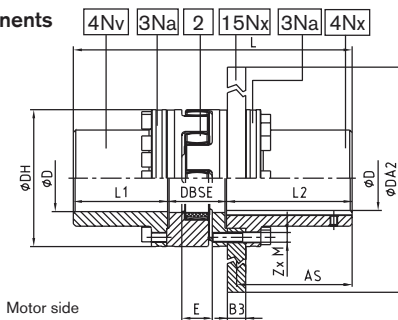

ROTEX® Type AFN-SB special												
Size	Spider <sup>1)</sup> Rated torque [Nm]			Dimensions [mm]								
	92 ShA	98 ShA	64 ShD	Finish bore D (min. - max.)	DH	L	L1	L2	E	S	DBSE	DI1
65	625	940	1175	22 - 70	135	344.5	113.5	166.0	35	4.5	65	68
75	1280	1920	2400	30 - 80	160	374.5	133.0	166.5	40	5.0	75	80
90	2400	3600	4500	40 - 105	200	454.0	165.5	206.5	45	5.5	82	100
100	3300	4950	6185	46 - 115	225	458.5	155.0	206.5	50	6.0	97	113
110	4800	7200	9000	60 - 130	255	518.5	203.5	212.0	55	6.5	103	127
125	6650	10000	12500	60 - 150	290	528.5	200.5	212.0	60	7.0	116	147
140	8550	12800	16000	60 - 170	320	627.5	247.0	252.5	65	7.5	128	165
160	12800	19200	24000	80 - 200	370	627.5	229.0	252.5	75	9.0	146	190
180	18650	28000	35000	85 - 230	420	609.5	198.0	252.5	85	10.5	159	220

Brake disk													
ROTEX® size	Brake disk						ROTEX® size	Brake disk					
	Dimensions [mm]			max. speed [rpm] <sup>3)</sup>	Weight [kg]	Mass moment of inertia [kgm <sup>2</sup> ]		Dimensions [mm]			max. speed [rpm] <sup>3)</sup>	Weight [kg]	Mass moment of inertia [kgm <sup>2</sup> ]
	DA2	B3	AS					DA2	B3	AS			
65	355	30	150	4850	19.7	0.34	125	630	30	195	2600	63.5	3.57
	400	30	150	4300	25.5	0.54		710	30	195	2400	83.3	5.80
	450	30	150	3800	32.7	0.87		800	30	195	2150	108.5	9.40
75	400	30	150	4300	26.8	0.58	140	710	30	235	2400	80.8	5.76
	450	30	150	3800	34.6	0.94		800	30	235	2150	105.9	9.36
	500	30	150	3500	43.4	1.44		900	30	235	1900	137.3	15.06
90	450	30	190	3800	32.7	0.93	160	900	40	230	1900	183.1	20.08
	500	30	190	3500	41.5	1.43		1000	40	230	1700	229.9	30.68
	560	30	190	3050	53.3	2.26		710	30	235	2000	76.9	5.68
100	630	30	190	2700	68.7	3.63	180	800	30	235	2000	101.9	9.28
	500	30	10	3500	40.4	1.42		900	30	235	1900	133.4	14.98
	560	30	190	3050	52.1	2.25		900	40	230	1900	177.9	19.97
110	630	30	190	2700	67.5	3.62	180	1000	40	230	1700	224.8	30.57
	500	30	195	3000	38.9	1.40		710	30	235	1800	70.8	5.52
	560	30	195	3000	50.7	2.23		800	30	235	1800	95.9	9.12
110	630	30	195	2700	66.1	3.60	180	900	30	235	1800	127.4	14.82
	710	30	195	2400	85.9	5.83		900	40	235	1800	169.9	19.75
								1000	40	235	1700	216.7	30.36

<sup>1)</sup> For selection see page 14 et seqq.

<sup>2)</sup> The maximum braking torque must not exceed the maximum torque of the coupling.

<sup>3)</sup> For circumferential speeds exceeding  $v = 30$  m/s dynamic balancing is required.

Ordering example:	ROTEX® 90	AFN-SB special	Ø450x30	98 ShA	4Nv	Ø90	4Nx	Ø90
	Coupling size	Type	Brake disk Ø x width	Spider hardness	Component	Finish bore	Component	Finish bore

# ROTEX® SD

## Flexible jaw couplings

Flexible jaw and pin & bush couplings

ROTEX®

### Shiftable coupling shiftable at standstill

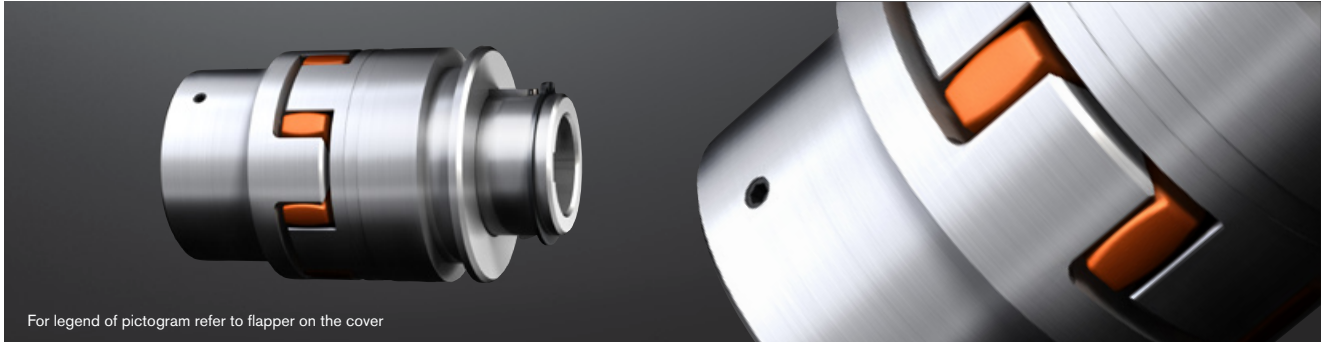

For legend of pictogram refer to flapper on the cover



ROFLEX®

### Components

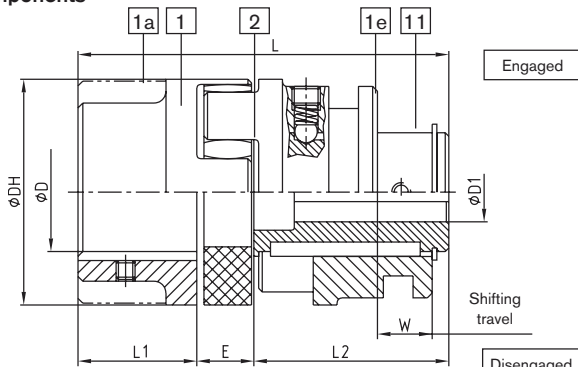

Type SD

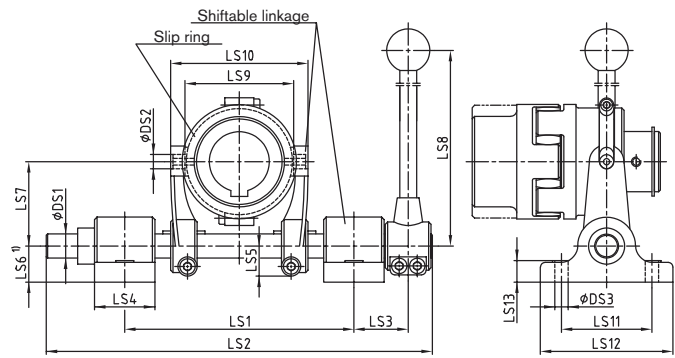

Type SD with slip ring and shiftable linkage

POLY-NORM®

Upon request: Shiftable linkage available with locking pin, locking device and retrieval of shift position.

ROTEX® Type SD														
Size	Spider <sup>1)</sup> Rated torque [Nm]			Dimensions [mm]								Set Shifting force [N]	Slip ring size	Shiftable linkage size
	92 ShA	98 ShA	64 ShD	Finish bore D (min. - max.)		DH	L	L1	L2	E	S			
				Component 1	Component 1Nd									
24	35	60	75	8	20	55	98	30	51.5	16.5	2.0	110	-	-
28	95	160	200	10	24	65	113	35	60.0	18.0	2.5	130	-	-
38	190	325	405	12	30	80	140	45	73.0	22.0	3.0	150	1.1	1
42	265	450	560	14	35	95	156	50	82.0	24.0	3.0	180	1.1	1
48	310	525	655	15	42	105	172	56	90.5	25.5	3.5	200	2.2	2
55	410	685	825	18	50	120	195	65	103.0	27.0	4.0	250	3.3	3
65	625	940	1175	20	55	135	227	75	120.0	32.0	4.5	280	3.3	3
75	1280	1920	2400	25	65	160	257	85	135.0	37.0	5.0	350	4.4	3
90	2400	3600	4500	28	75	200	293	100	152.0	41.0	5.5	350	5.5	4
100	3300	4950	6185	30	80	225	325	110	169.0	46.0	6.0	380	5.5	4
110	4800	7200	9000	35	85	255	355	120	184.0	51.5	6.5	450	5.5	4
125	6650	10000	12500	40	100	210.5	404	290	147	145	7.0	500	6.6	5

POLY-NORM®-M

Slip ring and shiftable linkage								
ROTEX® size	Shiftable linkage size	DS3	Dimensions [mm]				Max. speed [rpm] of slip ring	
			LS1		LS2	LS11		LS12
			min.	max.				
38	1							
42	1	11	180	190	320	75	110	3200
48	2		240	270	430			2500
55	3							
65	3		280	310	490	100	140	2100
75	3							1700
90	4	13.5						
100	4		321	365	565			1300
110	4					120	160	
125	5		365	410	630			1200

Finish bore according to ISO fit H7, feather keyway according to DIN 6885, sheet 1 [JS9].

REVOLEX®

Ordering example:	ROTEX® 38	SD	With 1.1 and 1	98 ShA	1	Ø38	1e+11	Ø28
	Coupling size	Type	With slip ring 1.1 and shiftable linkage 1	Spider hardness	Component	Finish bore	Component	Finish bore

# ROTEX® FNN Flexible jaw couplings

## For mounting of fan

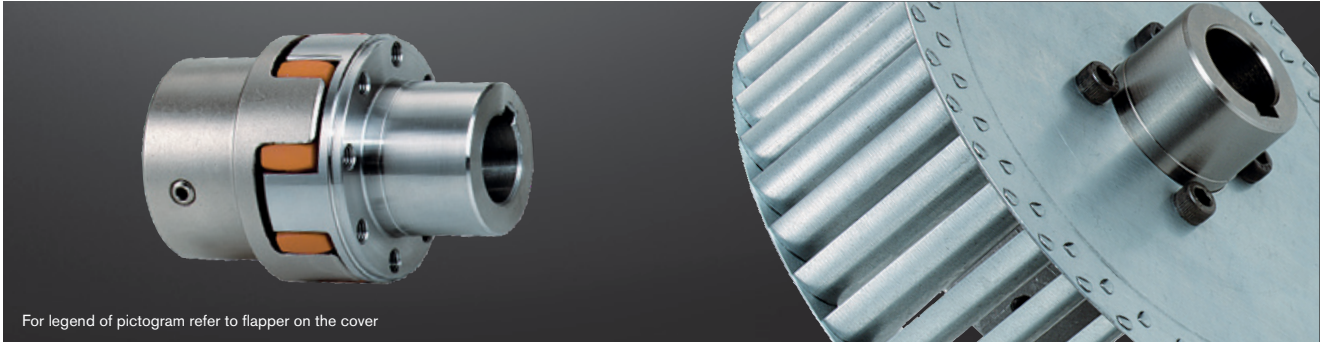

For legend of pictogram refer to flapper on the cover



### Components

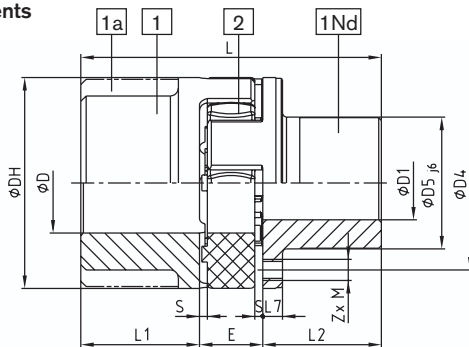

Type FNN

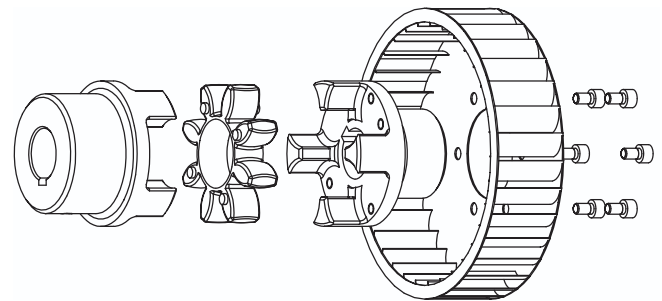

Type FNN with fan (type 1)

ROTEX® Type FNN																	
Size	Spider <sup>1)</sup> Rated torque [Nm]			Dimensions [mm]													
	92 ShA	98 ShA	64 ShD	Finish bore D (min. - max.)		DH	L	L1, L2	E	S	D5	D4	L7	M	Z	pitch	
				Component 1	Component 1Nd												
28	95	160	200	40	28	65	90	35	20	2.5	40	54	6.5	M 6	8	8x45°	
38	190	325	405	48	35	80	114	45	24	3.0	50	66	7.5	M 8	8		
42	265	450	560	55	42	95	126	50	26	3.0	60	80	9.5	M 8	12		
48	310	525	655	62	48	105	140	56	28	3.5	68	90	10.5	M 8	12	16x22.5°	
55	410	685	825	75	55	120	160	65	30	4.0	78	102	12.5	M 10	8	8x45°	
65	625	940	1175	80	68	135	185	75	35	4.5	92	116	13.5	M 10	12	16x22.5°	
75	1280	1920	2400	95	78	160	210	85	40	5.0	106	136	15.5	M 12	15	20x18°	
90	2400	3600	4500	110	104	200	245	100	45	5.5	140	172	18.5	M 16	15		

Other sizes on request.

Dimensioning of fans is customer-specific and depends on the coupling selection. Please advise all necessary details for dimensioning of your fan. For that purpose you may use the KTR questionnaire acc. to KTR-N 20008 sheet 1.

### Type 1: Fan screwed on

The ROTEX® hub can be supplied with the fan screwed on. Customised connection dimensions such as pitch circle of threads, size of threads and number or centering of fans must be specified in your inquiry.



### Type 2: Fan injection-moulded

Low prices due to optimisation of production with bigger volumes.

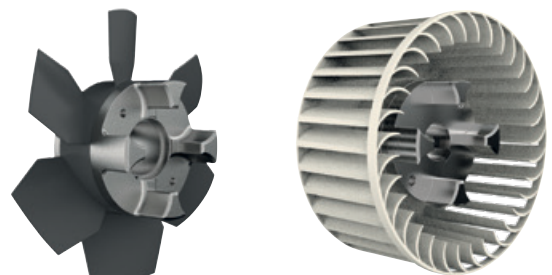

Ordering example:	ROTEX® 38	FNN	92 ShA	1	Ø38	1Nd	Ø30
	Coupling size	Type	Spider hardness	Component	Finish bore	Component	Finish bore

### Other types with clamping sets

#### Components

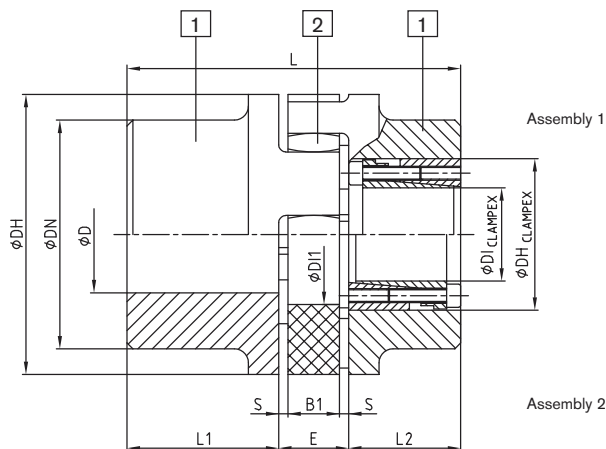

ROTEX® with clamping set CLAMPEX® KTR 200													
ROTEX® size	Hub material	CLAMPEX® KTR 200			Dimensions [mm]								
		Max. size of KTR clamping set DlxDH	Transmittable torque and axial force		L1	L2	E	B1	S	DH	DN	DI1	L
			T [Nm]	F <sub>AX</sub> [kN]									
42	Steel Component 1	30x55	790	53	50	48	26	20	3.0	95	—	46	Length = L1 + E + L2 (clamping set)
48		35x60	1300	74	56	48	28	21	3.5	105	—	51	
55		45x75	2200	98	65	59	30	22	4.0	120	—	60	
65		45x75	2200	98	75	59	35	26	4.5	135	115	68	
75		50x80	3330	132	85	59	40	30	5.0	160	135	80	
90	GJS Component 1	65x95	4300	132	100	59	45	34	5.5	200	160	100	Length = L1 + E + L2 (clamping set)
100		65x95	4300	132	110	59	50	38	6.0	225	180	113	
110		70x110	7500	214	120	70	55	42	6.5	255	200	127	
125		80x120	8500	213	140	70	60	46	7.0	290	230	147	
140		95x135	12600	265	155	70	65	50	7.5	320	255	165	
160		110x155	16500	300	175	80	75	57	9.0	370	290	190	
180		120x165	22500	375	195	80	85	64	10.5	420	325	220	

#### ROTEX® hub type 4.2 combined with CLAMPEX® KTR 250

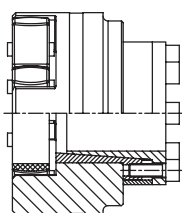

Frictionally engaged and backlash-free transmission of medium torques. CLAMPEX® KTR 250 is particularly suitable for thin-walled hubs and/or those made of aluminium or cast material. Please contact the KTR engineering department for any further details.

#### ROTEX® hub type 4.3 combined with CLAMPEX® KTR 400

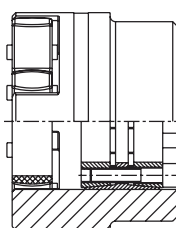

Frictionally engaged and backlash-free transmission of high torques. Compared to all other CLAMPEX® internal clamping sets, CLAMPEX® KTR 400 transmits the highest torques. Please contact the KTR engineering department for any further details.

#### ROTEX® hub type 4.9 combined with CLAMPEX® KTR 250

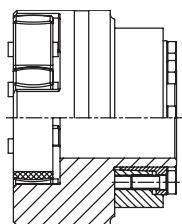

Frictionally engaged and backlash-free transmission of torques immediately between shaft and hub. Since CLAMPEX® KTR 620 is positioned outside on the hub, the hub is in direct contact with the shaft. This results in significantly higher concentricity compared to the combinations with CLAMPEX® KTR 250 or CLAMPEX® KTR 400. Please contact the KTR engineering department for any further details.

**Other types with torque limiter**



**ROTEX® BKN - Overload coupling, type BKN**

- Torsionally flexible coupling ROTEX® with shear pins
- Load-separating with blockage/overload
- Easy replacement of shear pin
- Fracture torque to be individually defined depending on the application

Customer variant from the stock programme.  
Please specify the fracture torques with your order!  
For further details see dimension sheet No. 5020/000/009-760313



**ROTEX® - RUFLEX® - Overload coupling**

- High power density
- Large wear volume with long service life
- Easy assembly and torque setting

For further details see catalogue page 270



**ROTEX® - KTR-SI - Overload coupling**

- Available in a ratchet, synchronous, idle rotation and fail-safe design
- High response accuracy, even after a long operating period
- Maintenance-free

For further details see catalogue page 277



**ROTEX® - KTR-SI FRE - idle rotation overload coupling**

- Idle rotation overload system for high torques
- High repeatability
- Intelligent further development of the shear pin coupling and hydraulic clamping sets

For further details see catalogue page 279

# ROTEX® Flexible jaw couplings

## Weights and mass moments of inertia

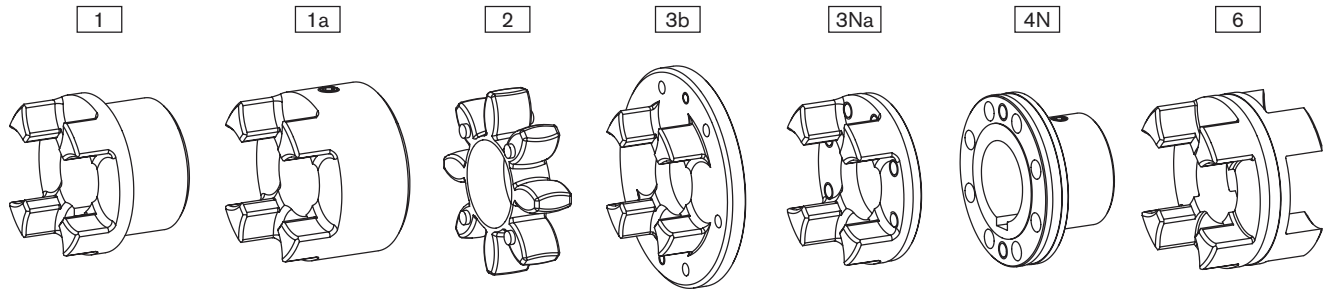

ROTEX® individual components														
Size	Standard hub				Large hub			Spider	Driving flange			Coupling flange	DKM spacer	
	Component 1				Component 1a			Component 2	Component 3b	Component 3Na			Component 4N	Component 6
	Aluminium [kg] [kgm <sup>2</sup> ]	GJL [kg] [kgm <sup>2</sup> ]	GJS [kg] [kgm <sup>2</sup> ]	St [kg] [kgm <sup>2</sup> ]	Aluminium [kg] [kgm <sup>2</sup> ]	GJL [kg] [kgm <sup>2</sup> ]	St [kg] [kgm <sup>2</sup> ]	Polyurethane (Vulkollan) [kg] [kgm <sup>2</sup> ]	GJS [kg] [kgm <sup>2</sup> ]	St [kg] [kgm <sup>2</sup> ]	GJS [kg] [kgm <sup>2</sup> ]	St [kg] [kgm <sup>2</sup> ]	St [kg] [kgm <sup>2</sup> ]	Aluminium [kg] [kgm <sup>2</sup> ]
14	—	—	—	—	0.020	—	—	0.0044	—	—	—	—	—	—
	—	—	—	—	0.000003	—	—	0.000005	—	—	—	—	—	—
19	0.064	—	—	—	0.074	—	0.25	0.0057	—	—	—	—	—	—
	0.00001	—	—	—	0.00002	—	0.00006	0.000001	—	—	—	—	—	—
24	0.123	—	—	—	0.174	—	0.55	0.014	0.028	0.145	—	0.30	0.14	—
	0.00004	—	—	—	0.00008	—	0.00023	0.000006	0.00023	0.00007	—	0.00009	0.00006	—
28	0.200	—	—	—	0.264	—	0.89	0.024	0.54	0.232	—	0.49	0.22	—
	0.00010	—	—	—	0.00019	—	0.00053	0.00001	0.0007	0.00017	—	0.0002	0.00013	—
38	0.44	1.16	—	1.6	0.470	1.32	1.74	0.042	0.73	—	0.313	0.87	0.35	—
	0.00033	0.00086	—	0.00151	0.00046	0.00135	0.00155	0.00004	0.001	—	0.00038	0.0005	0.00035	—
42	0.69	1.75	—	2.44	0.772	2.05	2.74	0.065	1.26	—	0.608	1.4	0.47	—
	0.00067	0.00178	—	0.00281	0.00111	0.00291	0.00343	0.00008	0.0032	—	0.00089	0.0011	0.00068	—
48	0.80	2.44	—	3.34	1.01	2.78	3.72	0.086	1.45	—	0.755	1.92	0.62	—
	0.0012	0.00308	—	0.00473	0.00174	0.00484	0.00570	0.00013	0.0043	—	0.001358	0.0018	0.0011	—
55	—	3.68	—	5.05	—	4.08	5.57	0.11	2.58	—	1.243	2.93	0.90	—
	—	0.00615	—	0.00948	—	0.00926	0.01193	0.00023	0.0105	—	0.002920	0.0037	0.0021	—
65	—	5.67	—	6.79	—	6.04	8.22	0.17	3.10	—	1.635	4.36	1.31	—
	—	0.01240	—	0.01516	—	0.01789	0.02079	0.00043	0.0149	—	0.004891	0.0069	0.0039	—
75	—	8.72	—	10.5	—	9.53	14.3	0.32	4.46	—	2.511	6.80	1.97	—
	—	0.02644	—	0.03269	—	0.03946	0.05069	0.001166	0.0281	—	0.01050	0.0151	0.0082	—
90	—	14.8	—	18.7	—	18.2	24.0	0.57	6.94	—	4.151	12.84	3.45	—
	—	0.06730	—	0.08742	—	0.15086	0.13151	0.00326	0.0651	—	0.02723	0.0448	0.0224	—
100	—	—	19.7	—	—	—	—	0.82	10.2	—	6.350	16.16	—	—
	—	—	0.11694	—	—	—	—	0.00592	0.1165	—	0.05273	0.0798	—	—
110	—	—	27.4	—	—	—	—	1.14	—	—	8.578	21.35	—	—
	—	—	0.20465	—	—	—	—	0.01048	—	—	0.09121	0.2824	—	—
125	—	—	42.3	—	—	—	—	1.56	—	—	12.598	34.33	—	—
	—	—	0.40727	—	—	—	—	0.01878	—	—	0.17469	0.3229	—	—
140	—	—	58.1	—	—	—	—	2.02	—	—	17.271	48.69	—	—
	—	—	0.67739	—	—	—	—	0.02989	—	—	0.29247	0.4917	—	—
160	—	—	84.2	—	—	—	—	3.08	—	—	26.305	71.08	—	—
	—	—	1.31729	—	—	—	—	0.06049	—	—	0.59436	0.9693	—	—
180	—	—	118.5	—	—	—	—	5.04	—	—	33.076	109.43	—	—
	—	—	2.30835	—	—	—	—	0.13295	—	—	0.97394	1.9650	—	—

Weight and mass moment of inertia each refer to the average finish bore without feather keyway.

For continuously updated data refer to our online catalogue at [www.ktr.com](http://www.ktr.com)

ROTEX®  
 Flexible jaw and pin & bush couplings  
 ROFLEX®  
 POLY-NORM®  
 POLY-NORM®-M  
 REVOLEX®

# ROTEX®

## Flexible jaw couplings

### Weights and mass moments of inertia

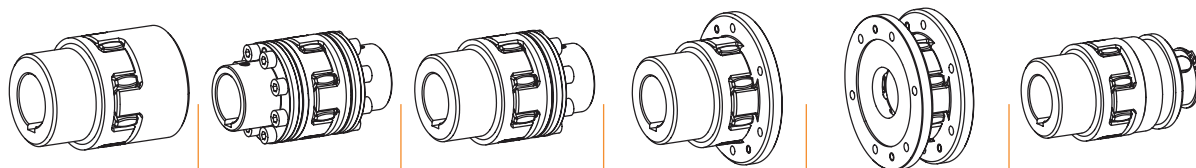

ROTEX® Complete coupling types												
Size	Standard		AFN		BFN		CF		DF		SD	
	Weight [kg]	Mass moment of inertia J [kgm²]	Weight [kg]	Mass moment of inertia J [kgm²]	Weight [kg]	Mass moment of inertia J [kgm²]	Weight [kg]	Mass moment of inertia J [kgm²]	Weight [kg]	Mass moment of inertia J [kgm²]	Weight [kg]	Mass moment of inertia J [kgm²]
19	0.51	0.000121	—	—	—	—	0.44	0.00016	0.38	0.00020	0.42	0.00008
24	1.1	0.000466	0.98	0.00036	1.1	0.00041	0.84	0.00047	0.57	0.00047	1.1	0.00046
28	1.8	0.00107	1.6	0.00083	1.7	0.00095	1.5	0.00124	1.1	0.00141	1.9	0.00106
38	2.5	0.00171	2.8	0.00209	2.6	0.00193	1.9	0.00217	1.5	0.00259	3.0	0.00435
42	3.9	0.00476	4.5	0.00472	4.1	0.00419	3.1	0.00513	2.6	0.00662	4.4	0.00804
48	5.3	0.00805	5.9	0.00736	5.5	0.00684	3.9	0.00755	3.0	0.00881	6.2	0.00223
55	7.9	0.01564	8.9	0.01480	8.3	0.01369	6.4	0.01692	5.3	0.02131	9.8	0.0166
65	11.9	0.03071	12.9	0.0266	12.3	0.0259	8.9	0.02780	6.4	0.003037	14.9	0.0326
75	18.6	0.06706	20.6	0.0601	19.3	0.0572	13.5	0.0557	9.2	0.05741	23.2	0.0706
90	33.6	0.22139	37.8	0.1718	34.2	0.1551	22.3	0.1356	14.5	0.1333	40.5	0.1891
100	40.2	0.23976	49.6	0.3068	45.2	0.2737	30.9	0.2401	21.2	0.2394	46.7	0.2467
110	56.0	0.42027	67.5	0.5385	61.7	0.4793	42.9	0.4324	29.8	0.4446	61.5	0.4186
125	86.2	0.83426	102.6	1.0485	94.4	0.9413	64.4	0.8187	42.2	0.8031	96.8	0.8497
140	118.3	1.38607	141.2	1.743	129.7	1.564	90.4	1.4221	62.5	1.4580	127.8	1.368
160	171.6	2.69781	210.3	3.517	190.9	3.107	127.6	2.589	83.6	2.4805	190.3	2.723
180	242.25	4.75449	306.6	6.582	274.4	5.668	175.1	4.448	107.9	4.141	262.2	4.810

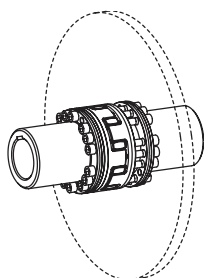

#### AFN-SB spec. without brake disk

Size	Weight [kg]	Mass moment of inertia J [kgm²]
65	13.7	0.03126
75	21	0.06828
90	39	0.20132
100	53	0.34637
110	74	0.61684
125	101	1.12844
140	145	1.95075
160	200	3.67846
180	262	6.41621

### Technical data

ROFLEX® Technical data													
Size	Torque [Nm] DIN 740 <sup>1)</sup>		max. speed [rpm] <sup>2)</sup>	Torsion spring stiffness Ct dyn. [Nm/rad]				Max. perm. displacement $\Delta K_W$ [mm] with n = 1500 rpm			Max. perm. displacement $\Delta K_W$ [mm] with n = 3000 rpm		
	Rated torque $T_{KN}$	Maximum torque $T_{K max}$		with v = 35 m/s	1.0 $T_{KN}$	0.75 $T_{KN}$	0.5 $T_{KN}$	0.3 $T_{KN}$	Axial $\Delta K_a$	Radial $\Delta K_r$	Angular $\Delta K_W$ (1°)	Axial $\Delta K_a$	Radial $\Delta K_r$
68	65	180	8500	3.48x10 <sup>3</sup>	2.66x10 <sup>3</sup>	2.24x10 <sup>3</sup>	2.01x10 <sup>3</sup>	± 1.00	0.20	0.20	± 1.00	0.14	0.14
80	80	220	7500	7.73x10 <sup>3</sup>	4.72x10 <sup>3</sup>	2.74x10 <sup>3</sup>	1.97x10 <sup>3</sup>	± 1.00	0.23	0.23	± 1.00	0.16	0.16
95	125	345	6800	1.43x10 <sup>4</sup>	8.99x10 <sup>3</sup>	5.36x10 <sup>3</sup>	3.81x10 <sup>3</sup>	± 1.00	0.23	0.23	± 1.00	0.16	0.16
110	205	565	6500	2.30x10 <sup>4</sup>	1.39x10 <sup>4</sup>	7.40x10 <sup>3</sup>	4.80x10 <sup>3</sup>	± 1.25	0.25	0.25	± 1.25	0.18	0.18
125	315	865	5800	3.48x10 <sup>4</sup>	2.05x10 <sup>4</sup>	1.12x10 <sup>4</sup>	7.20x10 <sup>3</sup>	± 1.25	0.28	0.28	± 1.25	0.20	0.20
140	450	1240	5400	5.52x10 <sup>4</sup>	3.01x10 <sup>4</sup>	1.38x10 <sup>4</sup>	9.50x10 <sup>3</sup>	± 1.25	0.30	0.30	± 1.25	0.21	0.21
160	790	2170	4800	1.41x10 <sup>5</sup>	8.61x10 <sup>4</sup>	4.25x10 <sup>4</sup>	2.48x10 <sup>4</sup>	± 1.75	0.35	0.35	± 1.75	0.25	0.25
180	1150	3160	4350	2.26x10 <sup>5</sup>	1.30x10 <sup>5</sup>	7.11x10 <sup>4</sup>	4.97x10 <sup>4</sup>	± 1.75	0.35	0.35	± 1.75	0.25	0.25
200	1800	4950	3950	4.27x10 <sup>5</sup>	2.54x10 <sup>5</sup>	1.29x10 <sup>5</sup>	8.06x10 <sup>4</sup>	± 1.75	0.38	0.38	± 1.75	0.27	0.27
225	2100	5775	3600	3.74x10 <sup>5</sup>	2.22x10 <sup>5</sup>	1.32x10 <sup>5</sup>	9.03x10 <sup>4</sup>	± 2.50	0.43	0.43	± 2.50	0.30	0.30
250	3550	9765	3000	7.15x10 <sup>5</sup>	4.23x10 <sup>5</sup>	2.44x10 <sup>5</sup>	1.60x10 <sup>5</sup>	± 2.75	0.48	0.48	± 2.75	0.34	0.34
280	5000	13750	3000	1.04x10 <sup>6</sup>	6.19x10 <sup>5</sup>	3.24x10 <sup>5</sup>	1.96x10 <sup>5</sup>	± 2.75	0.50	0.50	± 2.75	0.36	0.36

<sup>1)</sup> For selection see page 14 et seqq.

<sup>2)</sup> If requested, coupling is dynamically balanced. For circumferential speeds exceeding v = 20 m/s dyn. balancing is recommended.

#### Axial displacement $\Delta K_a$

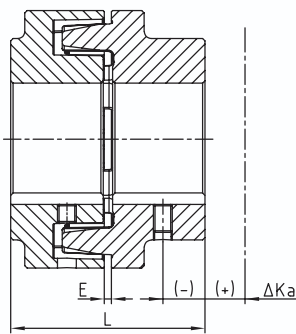

$$L_{max./min.} = L + \Delta K_a \text{ [mm]}$$

#### Radial displacement $\Delta K_r$

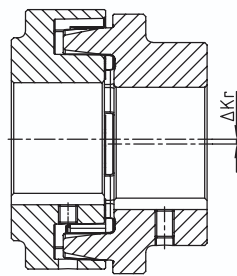

#### Angular displacement $\Delta K_W$

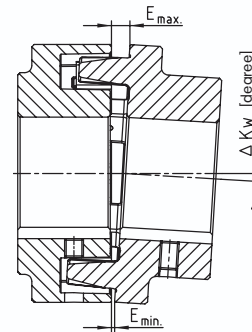

$$\Delta K_W = E_{max.} - E_{min.} \text{ [mm]}$$

### Advice for assembly

With assembly the coupling halves must be mounted in that coupling and shaft are flush. Alignment must be made in that radial and angular displacement is as small as possible. The service life of coupling and bearings is extended by accurate alignment. Steps must be taken to ensure that the alignment condition does not change during any operating condition. Inevitable shaft displacements should not exceed the figures specified in the table. Angular and radial displacement may occur simultaneously. See KTR assembly instructions, KTR standard 49310 on our homepage [www.ktr.com](http://www.ktr.com).

### General information about the torsion damper.

Size	68	80 - 280
Material/hardness	T-PUR/92 Shore A	Perbunan [NBR]/80 Shore A
Permanent temperature range in °C	-40 to +120	-30 to +80
Max. temperature (short-term) in °C	-40 to +150	-50 to +120
Operating range	General engineering Pump industry ATEX applications Chemical industry Standard applications with medium elasticity	General engineering Pump industry ATEX applications Chemical industry Standard applications with medium elasticity
Resistant to	Gasoline, diesel Acids, bases Use in the tropics (Salt) water (hot/cold) Oils, greases Propane, butane Natural gas, city gas	Gasoline, diesel Acids, bases Use in the tropics (Salt) water (hot/cold) Oils, greases Propane, butane Natural gas, city gas

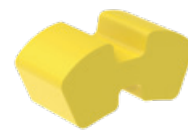

Torsion damper T-PUR 92 ShA



Torsion damper NBR 80 ShA

# ROFLEX® N

## Flexible jaw couplings

### Selection of standard IEC motors

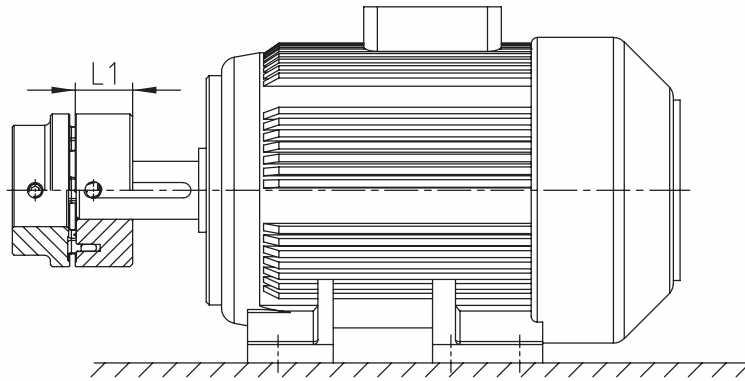

ROFLEX® couplings for standard IEC motors protection class IP 54/IP 55													
A. C. motor 50 Hz		Motor 2 poles n= 3000 rpm		ROFLEX® coupling size	Motor 4 poles n= 1500 rpm		ROFLEX® coupling size	Motor 6 poles n= 1000 rpm		ROFLEX® coupling size	Motor 8 poles n= 750 rpm		ROFLEX® coupling size
Size	Shaft end DxL [mm]		Power P [kW]		Torque T <sub>AN</sub> [Nm]	Power P [kW]		Torque T <sub>AN</sub> [Nm]	Power P [kW]		Torque T <sub>AN</sub> [Nm]	Power P [kW]	
	2 poles	4, 6, 8 poles		2 poles			4, 6, 8 poles			2 poles			4, 6, 8 poles
63	11 x 23		0.18	0.62		0.12	0.88		0.06	0.7			
			0.25	0.86		0.18	1.3		0.09	1.1		0.04	0.6
71	14 x 30		0.37	1.3		0.25	1.8		0.18	2		0.09	1.4
			0.55	1.9		0.37	2.5		0.25	2.8		0.12	1.8
80	19 x 40		0.75	2.5		0.55	3.7		0.37	3.9		0.18	2.5
			1.1	3.7		0.75	5.1		0.55	5.8		0.25	3.5
90S	24 x 50		1.5	5		1.1	7.5		0.75	8		0.37	5.3
90L	24 x 50		2.2	7.4	68	1.5	10	68	1.1	12	68	0.55	7.9
						2.2	15					0.75	11
100L	28 x 60		3	9.8		3	20		1.5	15		1.1	16
112M	28 x 60		4	13		4	27		2.2	22		1.5	21
132S	38 x 80		5.5	18		5.5	36		3	30		2.2	30
			7.5	25					4	40		3	40
132M	38 x 80					7.5	49		5.5	55	80		
160M	42 x 110		11	36		11	72		7.5	75	95	4	54
			15	49	80			95				5.5	74
160L	42 x 110		18.5	60		15	98		11	109		7.5	100
180M	48 x 110		22	71		18.5	121				110		
180L	48 x 110				95	22	144	110				11	145
200L	55 x 110		30	97		30	196		15	148		15	198
			37	120	110			125	22	215	125		
225S	55 x 110					37	240					18.5	244
225M	55 x 110	60 x 140	45	145		45	292	140	30	293	140	22	290
250M	60 x 140	65 x 140	55	177	125	55	356	160	37	361	160	30	392
280S	75 x 140		75	241		75	484		45	438		37	483
280M	75 x 140		90	289	140	90	581		55	535	160	45	587
315S	80 x 170		110	353		110	707		75	727		55	712
315M	80 x 170		132	423	160	132	849		90	873		75	971
			160	513		160	1030		110	1070	200	90	1170
315L	65 x 140		200	641		200	1290	200	132	1280	200	110	1420
					180				160	1550	225	132	1710
315	85 x 170		250	802		250	1600	225	200	1930	250	160	2070
			315	1010		315	2020		250	2410		200	2580
			355	1140	200	355	2280						
355	75 x 140	95 x 170	400	1280		400	2570		315	3040		250	3220
			500	1600	225	500	3210		400	3850		315	4060
			560	1790		560	3580		450	4330		355	4570
400	80 x 170	110 x 210	630	2020		630	4030		500	4810		400	5150
			710	2270		710	4540		560	5390		450	5790
			800	2560		800	5120		630	6060		500	6420
450	90 x 170	120 x 200	900	2880		900	5760		710	6830		560	7190
			1000	3200		1000	6400		800	7690		630	8090

The coupling selection is based on an ambient temperature of up to +30 °C. The selection is based on a minimum safety factor of 2 to the max. coupling torque (T<sub>K max</sub>). A detailed selection is possible according to catalogue page 15 et seqq. Drives with periodical torque curves must be selected according to DIN 740 part 2. If requested, KTR will perform the selection.

Torque T = rated torque according to Siemens catalogue D81.1 04/2024

# ROFLEX® N

## Flexible jaw couplings

Flexible jaw and pin & bush couplings

ROTEX®

ROFLEX®

POLY-NORM®

POLY-NORM®-M

REVOLEX®

### Two-part

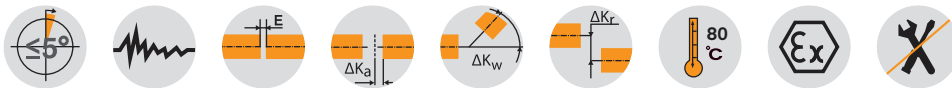
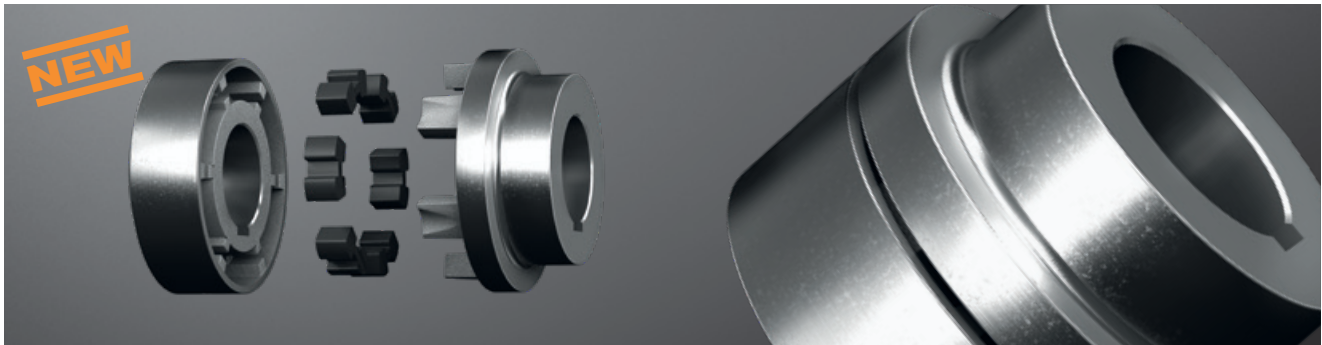

### Components

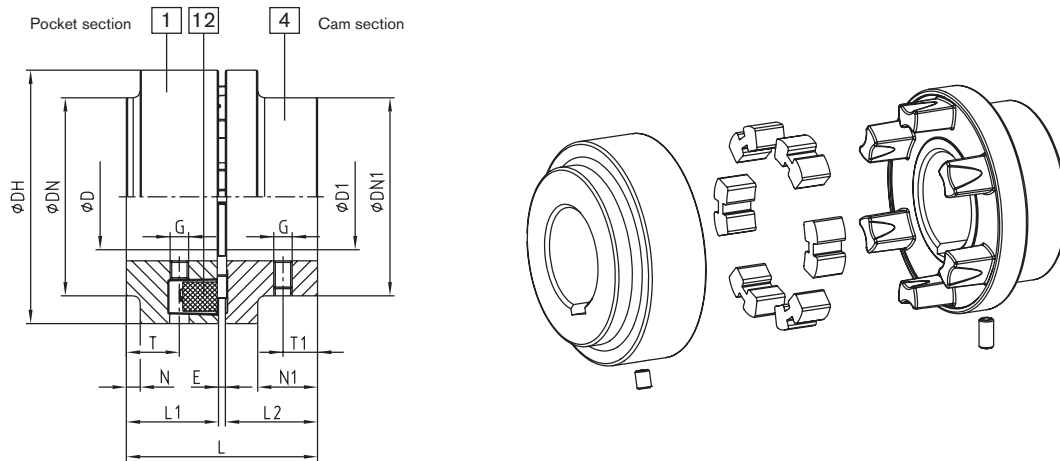

ROFLEX® type N																					
Size	Torque [Nm] acc. to DIN 740 <sup>1)</sup>		Max. speed [rpm]	Dimensions [mm]															Mass moment of inertia J1 [kgm <sup>2</sup> <sup>2)</sup>	Mass moment of inertia J4 [kgm <sup>2</sup> <sup>2)</sup>	Weight [kg] <sup>2)</sup>
	TKN	TK max		Max. finish bore			General						Thread for setscrews								
				D	D1	DH	L	L1, L2	DN	DN1	E	N	N1	G	T	T1	TA [Nm]				
68	65	180	8500	28	38	68	43	20	-	-	3	-	-	M 5	8.5	8	2	0.00016	0.00029	0.6	
80	80	220	7500	35	45	80	63	30	-	68	3	-	20	M 8	20.5	12	10	0.00059	0.00055	1.2	
95	125	345	6800	45	48	95	73	35	76	76	3	5	23	M 8	22	15	10	0.00116	0.00120	1.9	
110	205	565	6500	50	55	110	83	40	86	86	3	6	26	M 8	24	18	10	0.0024	0.0024	2.9	
125	315	865	5800	60	65	125	103	50	100	100	3	14	32	M 8	32	20	10	0.0046	0.0052	4.5	
140	450	1240	5400	70	65	140	113	55	100	100	3	21	35	M 10	13	22	17	0.0062	0.0077	5.3	
160	790	2170	4800	75	70	160	124	60	108	108	4	21	40	M 10	13	25	17	0.014	0.013	8.1	
180	1150	3160	4350	85	80	180	144	70	125	125	4	28	50	M 10	16	32	17	0.021	0.023	11.0	
200	1800	4950	3950	90	90	200	164	80	140	140	4	33	56	M 12	20	40	40	0.038	0.044	16.3	
225	2100	5775	3600	100	100	225	184	90	150	150	4	38	72	M 12	22	40	40	0.06	0.06	20.4	
250	3550	9765	3000	110	110	250	205.5	100	165	165	5.5	40	82	M 16	24	45	80	0.11	0.10	28.2	
280	5000	13750	3000	120	120	280	225.5	110	180	180	5.5	45	90	M 16	28	45	80	0.19	0.16	38.1	

<sup>1)</sup> see catalogue page 15

<sup>2)</sup> Mass moments of inertia J1 and J4 as well as the total weight refer to the maximum bore diameters

Ordering example:	ROFLEX® 110	N	ØD = 50	ØD1 = 55
	Coupling size	Type	Finish bore	Finish bore

# ROFLEX® SH

## Flexible jaw couplings

### Coupling with SPLIT hub

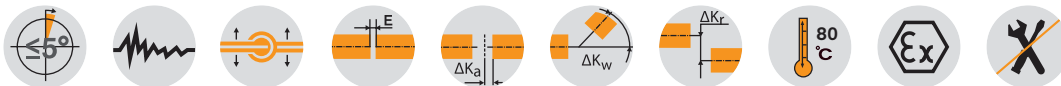
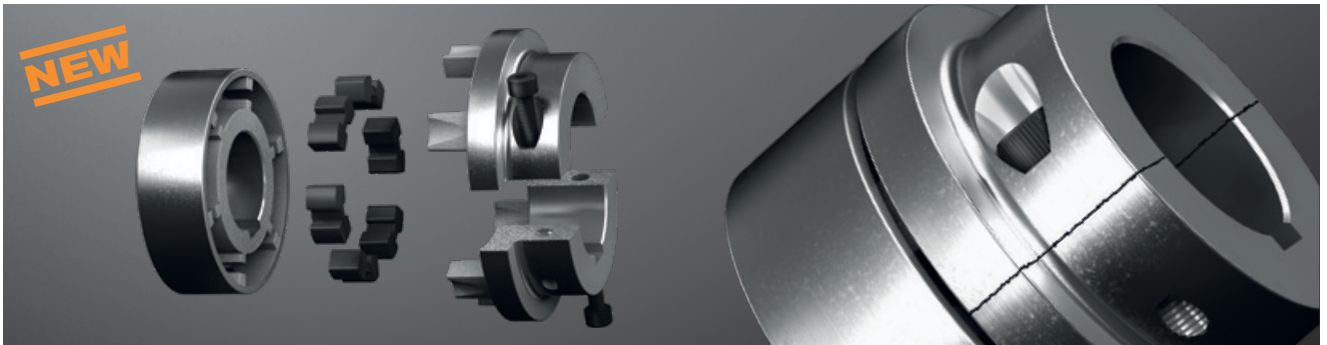

### Components

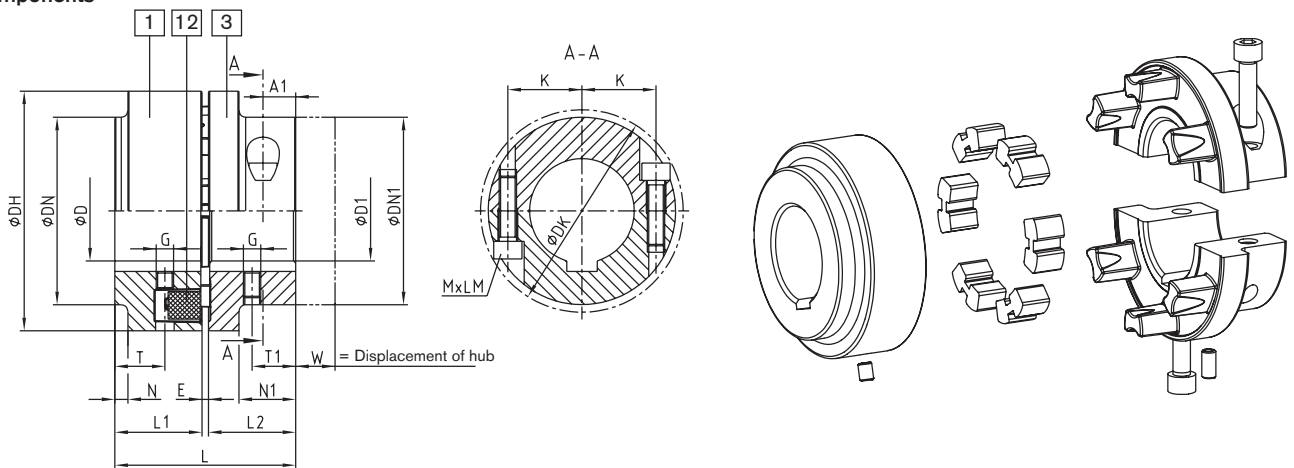

ROFLEX® type SH																												
Size	Torque [Nm] DIN 740 <sup>1)</sup>		Max. speed [rpm]	Max. finish bore		Dimensions [mm]															Mass moment of inertia J1 [kgm <sup>2</sup> ] <sup>2)</sup>	Mass moment of inertia J3 [kgm <sup>2</sup> ] <sup>2)</sup>	Weight [kg] <sup>2)</sup>					
	TKN	TK max		D	D1	General					Thread for setscrews					Cap screws												
						DH	L	L1	L2	E	DN	DN1	N	N1	W	G	T	T1	T <sub>A</sub> in Nm	MxLM				DK	K	A1	A2	T <sub>A</sub> in Nm
80	80	220	7500	35	38	80	63	30	30	3	80	68	-	20	15.5	M 8	20.5	12	10	M8x25	75	25	11	-	34	0.00059	0.00058	1.3
95	125	345	6800	45	42	95	73	35	35	3	76	76	5	23	18	M 8	22	15	10	M8x30	82	28.5	13	-	34	0.00116	0.00123	2.0
110	205	565	6500	50	48	110	83	40	40	3	86	86	6	26	21	M 8	24	18	10	M8x35	94	31.5	15	-	34	0.0024	0.0025	3.1
125	315	865	5800	60	55	125	103	50	50	3	100	100	14	32	23.5	M 8	32	20	10	M10x40	108	38.5	20	-	67	0.0046	0.0052	4.5
140	450	1240	5400	70	60	140	113	55	55	3	100	100	21	35	25	M 10	13	22	17	M10x35	108	39.0	10.5	25.5	67	0.0062	0.0080	5.7
160	790	2170	4800	75	65	160	124	60	60	4	108	108	21	40	30	M 10	13	25	17	M12x35	118	42.5	12	29	115	0.014	0.014	8.5
180	1150	3160	4350	85	75	180	144	70	70	4	125	125	28	50	32	M 10	16	32	17	M12x40	135	50	15	35	115	0.021	0.024	11.6
200	1800	4950	3950	90	85	200	164	80	80	4	140	140	33	56	34	M 12	20	40	40	M16x50	153	54	17	40	290	0.038	0.044	17.8
225	2100	5775	3600	100	90	225	184.0	90	90	4.0	150	150	38	73	39.0	M 12	22	40	40	M20x50	170	58	22	30	560	0.06	0.06	20.4
250	3550	9765	3000	110	100	250	205.5	100	100	5.5	165	165	40	82	44.5	M 16	24	40	80	M20x55	182	63	25	35	560	0.11	0.1	28.2
280	5000	13750	3000	120	120	280	225.5	110	110	5.5	180	180	45	90	50.0	M 16	28	45	80	M16x60	194	72	17	29	290	0.19	0.16	38.1

<sup>1)</sup> see catalogue page 15

<sup>2)</sup> Mass moments of inertia J1 and J3 as well as the total weight refer to the maximum bore diameters

Ordering example:	ROFLEX® 110	SH	ØD = 42	ØD1 = 48
	Coupling size	Type	Finish bore	Finish bore

### Technical data

POLY-NORM® Technical data													
Size	Torque [Nm] DIN 740 <sup>1)</sup>			max. speed in rpm with v = 35 m/s	Twisting angle [°] with		Torsion spring stiffness C dyn. [Nm/rad]				Max. perm. displacement [mm] <sup>2)</sup>		
	Rated torque T <sub>KN</sub>	Maximum torque T <sub>K max</sub>	Vibratory torque T <sub>KW</sub>		T <sub>KN</sub>	T <sub>K max</sub>	1.0 T <sub>KN</sub>	0.75 T <sub>KN</sub>	0.5 T <sub>KN</sub>	0.25 T <sub>KN</sub>	Axial ΔK <sub>a</sub>	Radial ΔK <sub>r</sub>	Angular ΔK <sub>w</sub>
28	40	80	16	9650			0.52x10 <sup>4</sup>	0.332x10 <sup>4</sup>	0.187x10 <sup>4</sup>	0.09x10 <sup>4</sup>	± 1.0	0.20	1.2
32	60	120	24	8550	4.5	6.0	0.782x10 <sup>4</sup>	0.499x10 <sup>4</sup>	0.282x10 <sup>4</sup>	0.135x10 <sup>4</sup>	± 1.0	0.25	1.4
38	90	180	36	7650			1.35x10 <sup>4</sup>	0.864x10 <sup>4</sup>	0.489x10 <sup>4</sup>	0.234x10 <sup>4</sup>	± 1.0	0.25	1.5
42	150	300	60	6950			2.63x10 <sup>4</sup>	1.68x10 <sup>4</sup>	0.947x10 <sup>4</sup>	0.453x10 <sup>4</sup>	± 1.0	0.25	1.7
48	220	440	88	6300			2.99x10 <sup>4</sup>	1.91x10 <sup>4</sup>	1.08x10 <sup>4</sup>	0.516x10 <sup>4</sup>	± 1.5	0.30	1.8
55	300	600	120	5650			3.85x10 <sup>4</sup>	2.46x10 <sup>4</sup>	1.39x10 <sup>4</sup>	0.664x10 <sup>4</sup>	± 1.5	0.30	2.0
60	410	820	164	5150			6.76x10 <sup>4</sup>	4.31x10 <sup>4</sup>	2.32x10 <sup>4</sup>	1.17x10 <sup>4</sup>	± 1.5	0.30	2.2
65	550	1100	220	4750	4.0	5.5	8.18x10 <sup>4</sup>	5.22x10 <sup>4</sup>	2.7x10 <sup>4</sup>	1.41x10 <sup>4</sup>	± 1.5	0.35	2.4
75	850	1700	340	4200			12.29x10 <sup>4</sup>	7.84x10 <sup>4</sup>	4.06x10 <sup>4</sup>	2.12x10 <sup>4</sup>	± 1.5	0.40	2.7
85	1350	2700	540	3650			24.31x10 <sup>4</sup>	15.51x10 <sup>4</sup>	7.49x10 <sup>4</sup>	4.19x10 <sup>4</sup>	± 1.5	0.40	3.0
90	2000	4000	800	3300			36.16x10 <sup>4</sup>	23.07x10 <sup>4</sup>	11.14x10 <sup>4</sup>	6.24x10 <sup>4</sup>	± 1.5	0.45	3.4
100	2900	5800	1160	2950			54.82x10 <sup>4</sup>	34.98x10 <sup>4</sup>	16.89x10 <sup>4</sup>	9.46x10 <sup>4</sup>	± 3.0	0.50	3.9
110	3900	7800	1560	2650			79.23x10 <sup>4</sup>	50.55x10 <sup>4</sup>	24.4x10 <sup>4</sup>	13.67x10 <sup>4</sup>	± 3.0	0.60	4.3
125	5500	11000	2200	2350	2.5	3.5	102.3x10 <sup>4</sup>	65.28x10 <sup>4</sup>	31.52x10 <sup>4</sup>	17.65x10 <sup>4</sup>	± 3.0	0.60	4.8
140	7200	14400	2880	2100			164x10 <sup>4</sup>	104.7x10 <sup>4</sup>	50.85x10 <sup>4</sup>	28.3x10 <sup>4</sup>	± 3.0	0.60	5.5
160	10000	20000	4000	1900			209.1x10 <sup>4</sup>	133.4x10 <sup>4</sup>	64.82x10 <sup>4</sup>	36.07x10 <sup>4</sup>	± 3.0	0.65	6.1
180	13400	26800	5360	1650			267.1x10 <sup>4</sup>	170.4x10 <sup>4</sup>	82.79x10 <sup>4</sup>	46.07x10 <sup>4</sup>	± 3.0	0.65	6.0
200	19000	38000	7600	1450			159.5x10 <sup>4</sup>	126.2x10 <sup>4</sup>	96.24x10 <sup>4</sup>	60.2x10 <sup>4</sup>	± 4.0	0.65	7.8
220	30000	60000	12000	1300			218.8x10 <sup>4</sup>	174x10 <sup>4</sup>	128.7x10 <sup>4</sup>	77.84x10 <sup>4</sup>	± 4.0	0.70	8.7
240	43000	86000	17200	1200	1.5	2.1	567.9x10 <sup>4</sup>	438.3x10 <sup>4</sup>	301.6x10 <sup>4</sup>	161.9x10 <sup>4</sup>	± 4.0	0.70	9.6
260	55000	110000	22000	1000			663.8x10 <sup>4</sup>	539.4x10 <sup>4</sup>	382.2x10 <sup>4</sup>	195.5x10 <sup>4</sup>	± 4.0	0.85	11.3
280	67000	134000	26800	950			773.1x10 <sup>4</sup>	628.1x10 <sup>4</sup>	467.9x10 <sup>4</sup>	266.2x10 <sup>4</sup>	± 4.0	0.95	12.2

<sup>1)</sup> see catalogue page 15

<sup>2)</sup> Displacement with n = 1500 rpm

Radial and angular displacements may occur simultaneously. The combined sum of displacements must not exceed the values listed in the table. If requested, coupling is dynamically balanced (semi-key balancing G 6.3 with 1500 rpm). For circumferential speeds exceeding v = 20 m/s dyn. balancing is recommended.

#### Axial displacement ΔK<sub>a</sub>

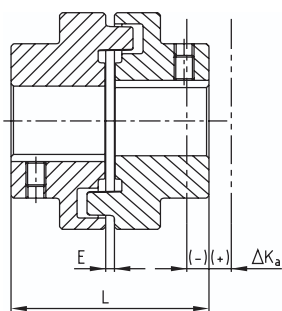

$$L_{\text{max./min.}} = L + \Delta K_a \text{ [mm]}$$

#### Radial displacement ΔK<sub>r</sub>

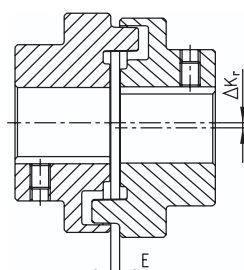

#### Angular displacement ΔK<sub>w</sub>

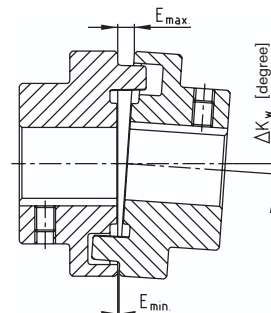

$$\Delta K_w = E_{\text{max.}} - E_{\text{min.}} \text{ [mm]}$$

#### Advice for assembly

With assembly the coupling halves must be mounted in that coupling and shaft are flush. Alignment must be made in that radial and angular displacement is as small as possible. The service life of coupling and bearings is extended by accurate alignment. Steps must be taken to ensure that the alignment condition does not change during any operating condition. Inevitable shaft displacements should not exceed the figures specified in the table. Angular and radial displacement may occur simultaneously. The combined sum of displacements must not exceed the values listed in the table above. See KTR assembly instructions, KTR standard 49510 on our homepage [www.ktr.com](http://www.ktr.com).

#### General information about the elastomer

Material/hardness	Perbunan [NBR]/78 Shore A
Permanent temperature range [°C]	-30 to +80
Max. temperature (short time) [°C]	-50 to +120
Operating range	General engineering Pump industry ATEX applications Chemical industry Standard applications with medium elasticity
Resistant to	Gasoline, diesel Acids, bases Use in the tropics (Salt) water (hot/cold) Oils, greases Propane, butane Natural gas, city gas



Elastomer ring NBR 78 Shore A

Elastomer ring Viton [FKM] 60 Shore A for the high-temperature range on request.

# POLY-NORM® Flexible coupling

## Selection of standard IEC motors

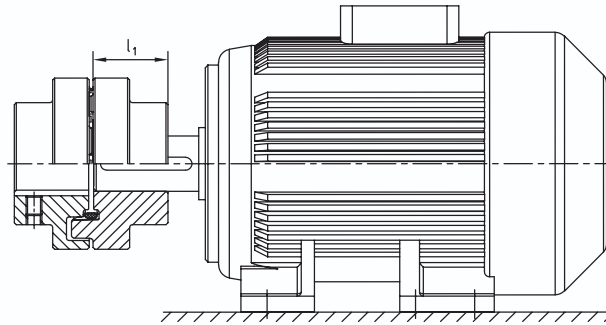

POLY-NORM® couplings for standard IEC motors, protection class IP 54/IP 55 (elastomer ring 78 Shore A)													
A. C. motor 50 Hz		Motor 2 poles n= 3000 rpm		POLY-NORM® coupling size	Motor 4 poles n= 1500 rpm		POLY-NORM® coupling size	Motor 6 poles n= 1000 rpm		POLY-NORM® coupling size	Motor 8 poles n= 750 rpm		POLY-NORM® coupling size
Size	Shaft end DxL [mm]		Power P [kW]		Torque T <sub>AN</sub> [Nm]	Power P [kW]		Torque T <sub>AN</sub> [Nm]	Power P [kW]		Torque T <sub>AN</sub> [Nm]	Power P in kW	
	2 poles	4, 6, 8 poles											
63	11 x 23		0.18	0.62		0.12	0.88		0.06	0.7			
			0.25	0.86		0.18	1.3		0.09	1.1		0.04	0.6
71	14 x 30		0.37	1.3		0.25	1.8		0.18	2		0.09	1.4
			0.55	1.9		0.37	2.5		0.25	2.8		0.12	1.8
80	19 x 40		0.75	2.5	28/32	0.55	3.7	28/32	0.37	3.9	28/32	0.18	2.5
			1.1	3.7		0.75	5.1		0.55	5.8		0.25	3.5
90S	24 x 50		1.5	5		1.1	7.5		0.75	8		0.37	5.3
90L	24 x 50		2.2	7.4		1.5	10		1.1	12		0.55	7.9
100L	28 x 60		3	9.8		2.2	15		1.5	15		0.75	11
112M	28 x 60		4	13		3	20		2.2	22		1.1	16
132S	38 x 80		5.5	18	38	5.5	36	38	3	30	38	1.5	21
			7.5	25		7.5	49		4	40		2.2	30
132M	38 x 80								5.5	55		3	40
160M	42 x 110		11	36	42	11	72	42	7.5	75	42	4	54
			15	49		15	98		11	109		5.5	74
160L	42 x 110		18.5	60		18.5	121		15	148		7.5	100
180M	48 x 110		22	71	48	22	144	48	15	148	48	11	145
			30	97		30	196		18.5	181		15	198
180L	48 x 110		37	120		37	240		22	215		18.5	244
200L	55 x 110				55	45	292	55	30	293	55	22	290
			45	145		45	292		30	293		22	290
225S	55 x 110	60 x 140	55	177	60	55	356	60	37	361	60	30	392
225M	55 x 110	60 x 140	75	241		75	484		75	438		37	483
250M	60 x 140	65 x 140	90	289	65	90	581	65	55	535	65	45	587
280S	75 x 140		110	353		110	707		110	727		55	712
280M	75 x 140		132	423	75	132	849	75	90	873	75	75	971
315S	80 x 170		160	513		160	1030		160	1070		90	1170
315M	65 x 140	80 x 170	200	641	85	200	1290	85	132	1280	85	110	1420
315L	85 x 170									160		1550	
315	85 x 170		250	802	90	250	1600	90	200	1930	90	160	2070
			315	1010		315	2020		315	2410		200	2580
355	75 x 140	95 x 170	355	1140	100	355	2280	100			100		
			400	1280		400	2570		400	3040		250	3220
			500	1600	110	500	3210	110	400	3850	110	315	4060
			560	1790		560	3580		560	4330		355	4570
400	80 x 170	110 x 210	630	2020	125	630	4030	125	500	4810	125	400	5150
			710	2270		710	4540		710	5390		450	5790
			800	2560	140	800	5120	140	630	6060	140	500	6420
			900	2880		900	5760		900	6830		560	7190
450	90 x 170	120 x 200	1000	3200	160	1000	6400	160	800	7690	160	630	8090

The coupling selection is based on an ambient temperature of up to +30 °C. The selection is based on a minimum safety factor of 2 to the max. coupling torque (T<sub>K max</sub>). A detailed selection is possible according to catalogue page 15 et seqq. Drives with periodical torque curves must be selected according to DIN 740 part 2. If requested, KTR will perform the selection.

Torque T = rated torque according to Siemens catalogue M 11 · 1994/95.

# POLY-NORM® AR

## Flexible couplings

### Two-part

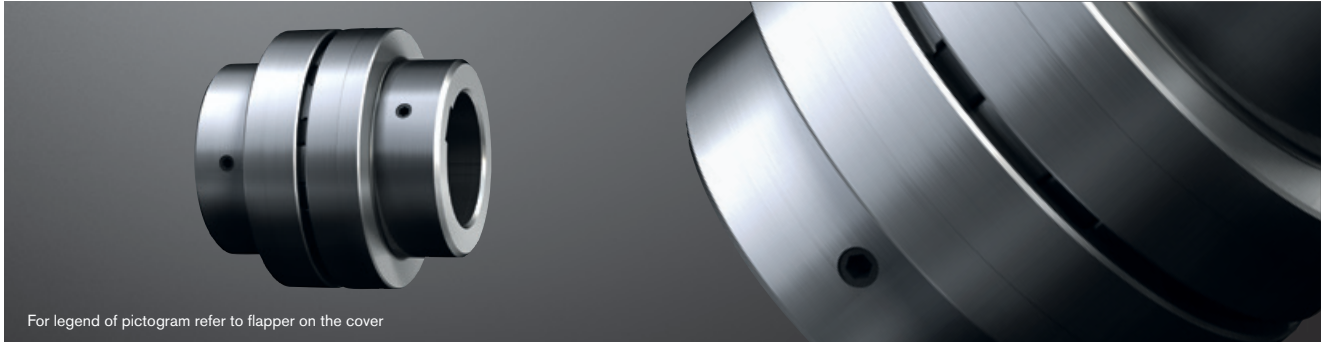

For legend of pictogram refer to flapper on the cover

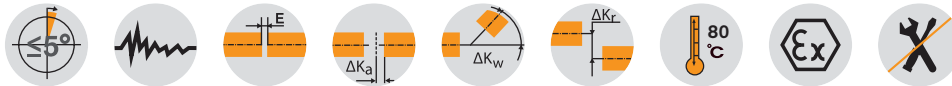

### Components

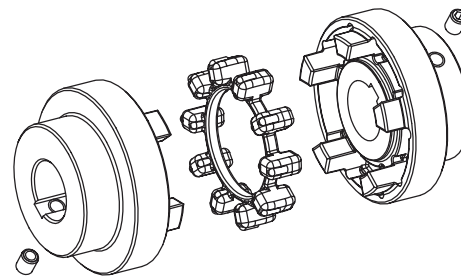
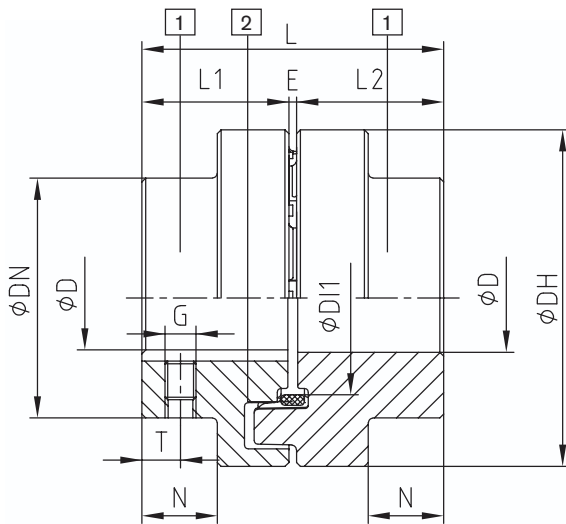

Size 28 - 125

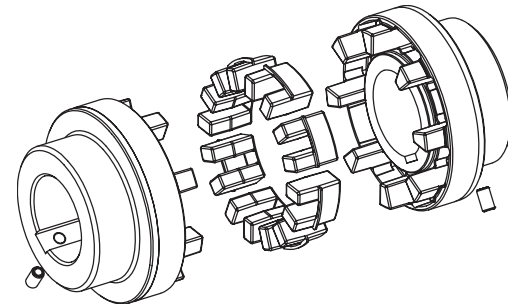

Size 140 - 280

Components of type AR:

1 = Standard hub (GJL)

2 = Elastomer ring (up to size 180: NBR 78 ShA; from size 200: T-PUR® 84 ShA)

POLY-NORM® Type AR															
Size	Elastomer ring <sup>1)</sup> (component <sup>2)</sup> Torque [Nm]		Max. finish bore D <sup>2)</sup>	Dimensions [mm]										Mass moment of inertia <sup>3)</sup> [kgm <sup>2</sup> ]	Weight <sup>3)</sup> [kg]
	T <sub>KN</sub>	T <sub>K max</sub>		General							Setscrew <sup>2)</sup>				
	DH	L		L1, L2	E	D	DI1	N	G	T					
28	40	80	12-30	69	59	28	3	46	36.5	12	M 5	7	0.0004	0.9	
32	60	120	12-35	78	68	32	4	53	41.5	14	M 8	7	0.0008	1.4	
38	90	180	19-40	87	80	38	4	62	50	19.5	M 8	10	0.0016	2.0	
42	150	300	19-45	96	88	42	4	69	55.5	20	M 8	10	0.0026	2.7	
48	220	440	19-50	106	101	48	5	78	64	24	M 8	15	0.0042	3.7	
55	300	600	19-60	118	115	55	5	90	73	29	M 8	14	0.0070	5.5	
60	410	820	19-65	129	125	60	5	97	81	33	M 8	15	0.0112	6.9	
65	550	1100	19-70	140	135	65	5	105	86	36	M 10	20	0.0174	8.8	
75	850	1700	32-80	158	155	75	5	123	100	42.5	M 10	20	0.028	13.5	
85	1350	2700	32-90	182	175	85	5	139	116	48.5	M 10	25	0.052	19.5	
90	2000	4000	32-95	200	185	90	5	148	128	49	M 12	25	0.090	23.2	
100	2900	5800	42-110	224	206	100	6	165	143	55	M 12	25	0.160	31.9	
110	3900	7800	50-120	250	226	110	6	185	158	60	M 16	30	0.317	38.0	
125	5500	11000	55-140	280	256	125	6	210	178	70	M 16	35	0.570	55.2	
140	7200	14400	65-155	315	286	140	6	235	216	76.5	M 20	35	1.030	92.6	
160	10000	20000	75-175	350	326	160	6	265	246	94.5	M 20	45	1.746	126.9	
180	13400	26800	75-200	400	366	180	6	300	290	111.5	M 20	50	3.239	181.8	
200	19000	38000	85-200	450	408	200	8	335	-	126	M 24	50	5.728	263.7	
220	30000	60000	95-220	500	448	220	8	370	-	140	M 24	50	9.489	355.9	
240	43000	86000	105-240	550	488	240	8	405	-	154	M 24	50	14.963	466.3	
260	55000	110000	115-260	650	530	260	10	440	-	158	M 24	60	29.504	672.2	
280	67000	134000	125-280	700	570	280	10	475	-	172	M 24	60	42.451	836.6	

<sup>1)</sup> Standard material Perbunan [NBR] 78 Shore A, size 140 - 280 double tooth elastomers, for selection see page 14 et seqq.

<sup>2)</sup> Bores H7 with keyway to DIN 6885 sheet 1 [JS9] and setscrew on the keyway

<sup>3)</sup> Referring to medium bore

# POLY-NORM® AR Flexible couplings

## For taper clamping sleeve

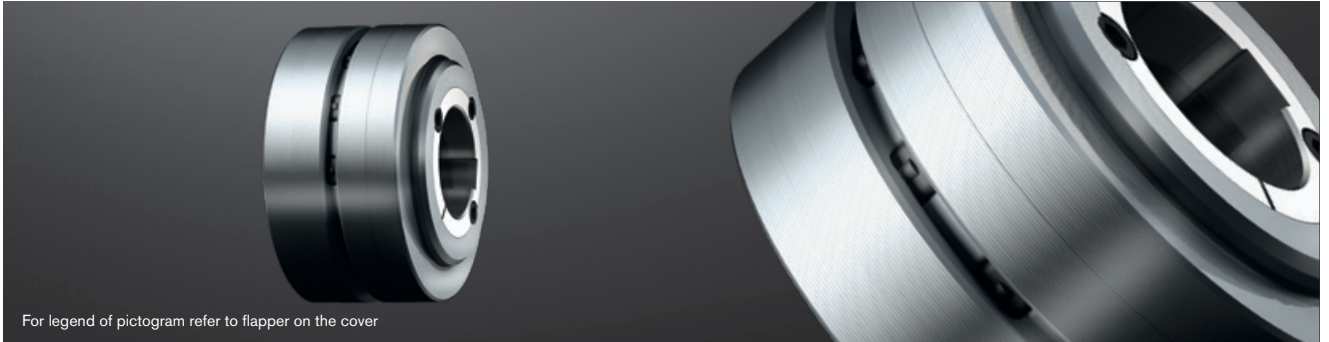

For legend of pictogram refer to flapper on the cover



### Components

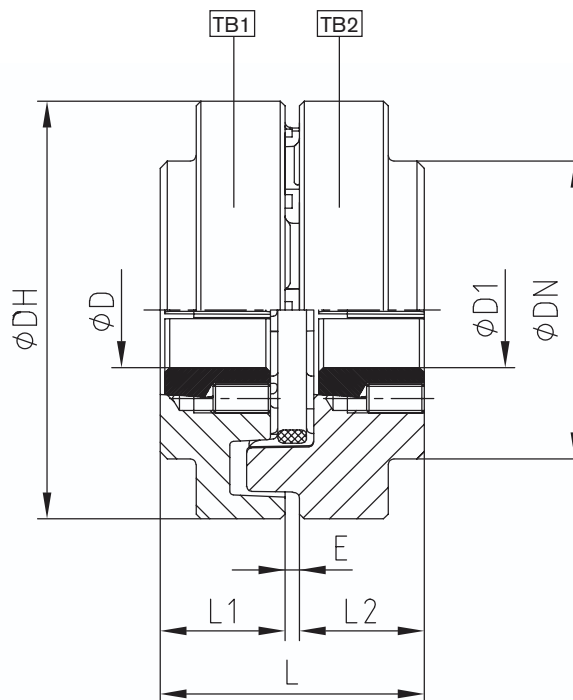

POLY-NORM® for taper clamping sleeve										
Size	Taper clamping sleeve	Dimensions [mm]					Fastening screws <sup>1</sup> for taper clamping sleeve			
		Max. d <sub>1</sub> , d <sub>2</sub>	DH	L	L <sub>1</sub>	E	Size [Inch]	Length [mm]	SW [mm]	T <sub>A</sub> [Nm]
32	1108	25	78	55	25.5	4	1/4"	13	3	5.7
42	1210	32	96	66	31.0	4	3/8"	16	5	20
48	1610	40	96	65	30.0	5	3/16"	16	5	20
	1615	40		90	42.5		3/8"	16	5	20
60	2012	50	129	82	38.5	5	7/16"	22	6	31
65	2517	60	140	130	62.5	5	1/2"	25	6	49
75	2517	60	158	110	52.5	5	1/2"	25	6	49
85	2517	60	182	98	46.5	5	1/2"	25	6	49
	3030	75		169	82.0		5/8"	32	8	90
90	3020	75	200	109	52.0	5	5/8"	32	8	92
100	3535	90	224	202	98.0	6	1/2"	38	10	115
125	4040	100	280	229	111.5	6	5/8"	45	12	172

<sup>1</sup>) Each 2 fastening screws, with 3535/4040 3-off  
For coupling type TB1 screw connection on cam side - TB2 screw connection on collar side  
Combination possible! Please order our separate dimension sheet (M407045).

Ordering example:	POLY-NORM® 32 AR TB1 / TB1	AR	Ø38	Ø30
	Coupling size	Type	Finish bore	Finish bore

# POLY-NORM® ADR Flexible couplings

## Three-part



For legend of pictogram refer to flapper on the cover



### Components

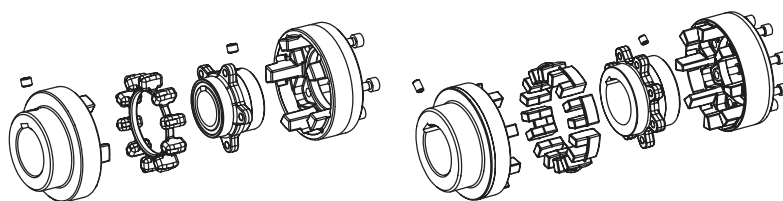
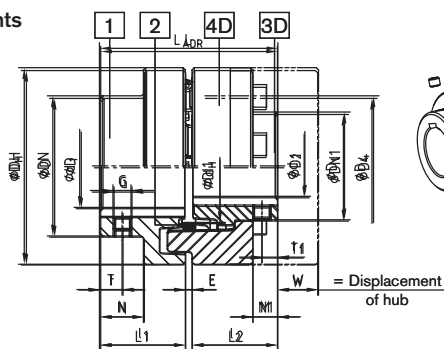

Size 38 - 125

Size 140 - 280

Components of type ADR (three-part):  
 1 = Standard hub\* (GJL)  
 2 = Elastomer ring (up to size 180: NBR 78 ShA; from size 200: T-PUR® 84 ShA)  
 3D = Flange hub (GJS); 4D = Cam ring (GJL)  
 \* To be preferably used on driving side

### POLY-NORM® Type ADR

Size	Elastomer ring <sup>1)</sup> (component 2) Torque [Nm]		Dimensions [mm]																
	T <sub>KN</sub>	T <sub>K max</sub>	Max. finish bore <sup>2)</sup>		General											Setscrew			
			D	D1	DH	L	L1, L2	E	DN	DN1	DI1	N	N1	W	G	T	T1	T <sub>A</sub> [Nm]	
38	90	180	40	34	87	80	38	4	62	48	50	19.5	11.0	12	M 8	10	7	10	
42	150	300	45	38	96	88	42	4	69	54	55.5	20	12.0	16	M 8	10	7	10	
48	220	440	50	44	106	101	48	5	78	62	64	24	13.7	16	M 8	15	7	10	
55	300	600	60	50	118	115	55	5	90	72	73	29	18.7	15	M 8	14	14	10	
60	410	820	65	56	129	125	60	5	97	80	81	33	22.2	14	M 8	15	15	10	
65	550	1100	70	60	140	135	65	5	105	86	86	36	26.7	11	M 10	20	20	17	
75	850	1700	80	68	158	155	75	5	123	98	100	42.5	27.8	16	M 10	20	20	17	
85	1350	2700	90	78	182	175	85	5	139	112	116	48.5	33.7	18	M 10	25	25	17	
90	2000	4000	95	85	200	185	90	5	148	122	128	49	31.5	26	M 12	25	25	40	
100	2900	5800	110	95	224	206	100	6	165	136	143	55	37.5	28	M 12	25	25	40	
110	3900	7800	50-120	105	250	226	110	6	185	150	158	60	39.5	30	M 16	30	30	80	
125	5500	11000	55-140	115	280	256	125	6	210	168	178	70	48.0	35	M 16	35	35	80	
140	7200	14400	65-155	55-135	315	286	140	6	235	195	216	76.5	47.0	59	M 20	35	35	140	
160	10000	20000	75-175	65-155	350	326	160	6	265	225	246	94.5	65.0	43	M 20	45	45	140	
180	13400	26800	75-200	65-175	400	366	180	6	300	255	290	111.5	79.0	33	M 20	50	50	140	
200	19000	38000	85-200	73-200	450	408	200	8	335	290	320	126	95	7	M 24	50	50	240	
220	30000	60000	95-220	83-220	500	448	220	8	370	320	354	140	103	8	M 24	50	50	240	
240	43000	86000	105-240	93-240	550	488	240	8	405	350	388	154	119	1	M 24	50	50	240	
260	55000	110000	115-260	103-260	650	530	260	10	440	380	445	158	109	34	M 24	60	60	240	
280	67000	134000	125-280	113-280	700	570	280	10	475	410	478	172	109	29	M 24	60	60	240	

### Selection of cap screws DIN EN ISO 4762 - 12.9

Size	M x l [mm]	z = number	Pitch z x angle	D <sub>4</sub> [mm]	T <sub>A</sub> [Nm] <sup>3)</sup>	Size	M x l [mm]	z = number	Pitch z x angle	D <sub>4</sub> [mm]	T <sub>A</sub> [Nm] <sup>3)</sup>
38	M6x16	5	5x72	62	10	110	M16x40	8	8x45	183	210
42	M8x16	5	5x72	69	25	125	M20x40	8	8x45	202	410
48	M8x20	6	6x60	78	25	140	M20x50	8	8x45	237	410
55	M8x20	6	6x60	88	25	160	M20x55	9	9x40	267	410
60	M8x20	6	6x60	98	25	180	M20x60	10	10x36	304	410
65	M10x20	6	6x60	104	49	200	M20x60	10	10x36	342	580
75	M10x25	6	6x60	120	49	220	M24x70	10	10x36	378	1000
85	M12x25	6	6x60	138	86	240	M27x70	10	10x36	416	1500
90	M16x30	6	6x60	149	210	260	M30x90	10	10x36	480	2000
100	M16x30	6	6x60	163	210	280	M30x90	10	10x36	520	2000

<sup>1)</sup> Standard material Perbunan [NBR] 78 Shore A, size 140 - 280 double tooth elastomers, for selection see page 14 et seqq.

<sup>2)</sup> Bores H7 with keyway to DIN 6885 sheet 1 [JS9] and setscrew <sup>3)</sup> Screw tightening torques acc. to 8.8

Ordering example:	POLY-NORM® 65	ADR	d <sub>1</sub> = Ø55	d <sub>2</sub> = Ø60
	Coupling size	Type	Finish bore	Finish bore

# POLY-NORM® BTA and SBA Flexible couplings

With brake drum/brake disk for brake stop

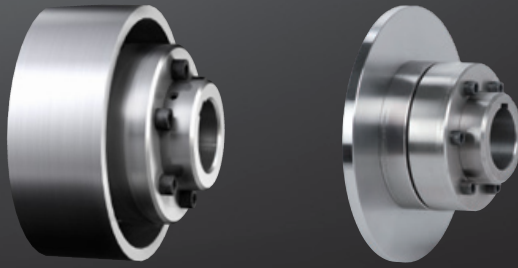

For legend of pictogram refer to flapper on the cover



## Components

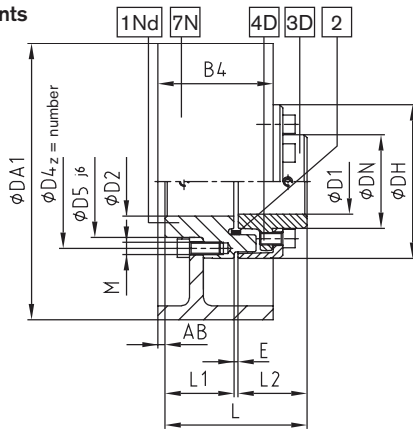

Brake drum type ADR-BTA

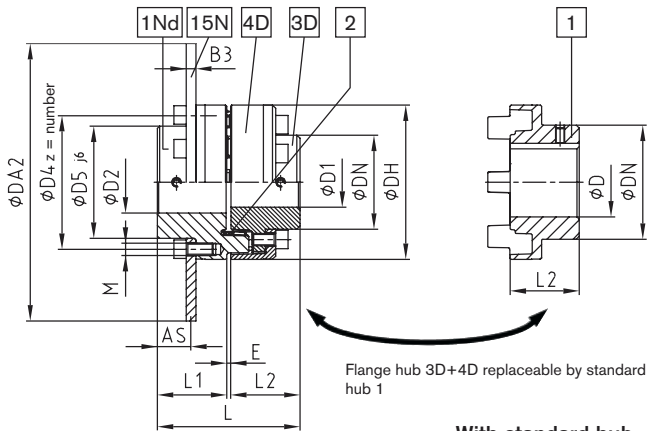

Brake disk type ADR-SBA

With standard hub type AR-BTA or AR-SBA

## POLY-NORM® Type AR-BTA, AR-SBA, ADR-BTA and ADR-SBA

Size	Elastomer ring <sup>1)</sup> (component 2) Torque [Nm]		Max. finish bore			DH	D4	D5	DN	z	M	L1, L2	E	L
	TKN	TK max	D1	D2	D3									
38	90	180	40	34	38	87	75	61	62	5 x 72°	M 6	38	4	80
42	150	300	45	38	42	96	82	68	69	5 x 72°	M 8	42	4	90
48	220	440	50	44	48	106	92	77	78	6 x 60°	M 8	48	5	101
55	300	600	60	50	55	118	104	88	90	6 x 60°	M 8	55	5	115
60	410	820	65	56	60	129	114	96	97	6 x 60°	M 8	60	5	125
65	550	1100	70	60	65	140	122	104	105	6 x 60°	M 10	65	5	135
75	850	1700	80	68	75	158	140	121	123	6 x 60°	M 10	75	5	155
85	1350	2700	90	78	85	182	160	137	139	6 x 60°	M 12	85	5	175
90	2000	4000	95	85	90	200	174	146	148	6 x 60°	M 16	90	5	185
100	2900	5800	110	95	100	224	195	164	165	6 x 60°	M 16	100	6	206
110	3900	7800	50-120	105	50-110	250	218	184	185	8 x 45°	M 16	110	6	226
125	5500	11000	55-140	115	55-125	280	245	208	210	8 x 45°	M 20	125	6	256
140	7200	14400	65-155	55-135	65-140	315	276	233	235	8 x 45°	M 20	140	6	286
160	10000	20000	75-175	65-155	75-160	350	308	263	265	9 x 40°	M 20	160	6	326
180	13400	26800	75-200	65-175	75-180	400	349	298	300	10 x 36°	M 20	180	6	366

## POLY-NORM® Type BTA

POLY-NORM® size	38	42	48	55	60	65	75	85	90	100	110	125	140	160	180	Max. speed [rpm] with v = 60 m/s <sup>3)</sup>
∅DA1xB4 brake drum <sup>2)</sup>	Dimensions AB [mm]															
160x60	4															7150
200x75	9	8	4													5725
250x95	17	16	20	7	3	0										4575
315x118		25	21	16	12	9	2.5	-3.5								3625
400x150			34	28	25	22	15.5	9.5	9	3						2850
500x190										18	12	-2				2275
630x236											20	13	-4			1800
710x265												24	7	-11		1600

## POLY-NORM® Type SBA

POLY-NORM® size	38	42	48	55	60	65	75	85	90	100	110	125	140	160	180	Max. speed [rpm] with v = 60 m/s <sup>3)</sup>
∅DA2xB3 brake disk <sup>2)</sup>	Dimensions AS [mm]															
200x12.5	13.75															5725
250x12.5	13.75	14.75	18.75													4575
315x16			13	17	22	26	29	35.5								3625
400x16				17	22	26	29	35.5	41.5	42	48					2850
500x16					22	26	29	35.5	41.5	42	48	54	64			2275
630x20											46	52	62	69	86	1800
710x20											46	52	62	69	86	1600
800x25											43.5	49.5	59.5	66.5	83.5	1425
900x25											49.5	59.5	66.5	83.5	101.5	1250

<sup>1)</sup> Standard material Perbunan [NBR], for selection see page 14 et seqq.

<sup>2)</sup> Steel

<sup>3)</sup> Dynamic balancing required

Other sizes on request

Ordering example:	POLY-NORM® 38	ADR-BTA	∅200 x 75	d <sub>2</sub> = ∅32 NnD	d <sub>3</sub> = ∅25 NnD
		Coupling size	Type	Brake drum ∅	Component with finish bore

# POLY-NORM® AZR

## Flexible couplings

Flexible jaw and pin & bush couplings

ROTEX®

ROFLEX®

POLY-NORM®

POLY-NORM®-M

REVOLEX®

### Standard drop-out center design coupling

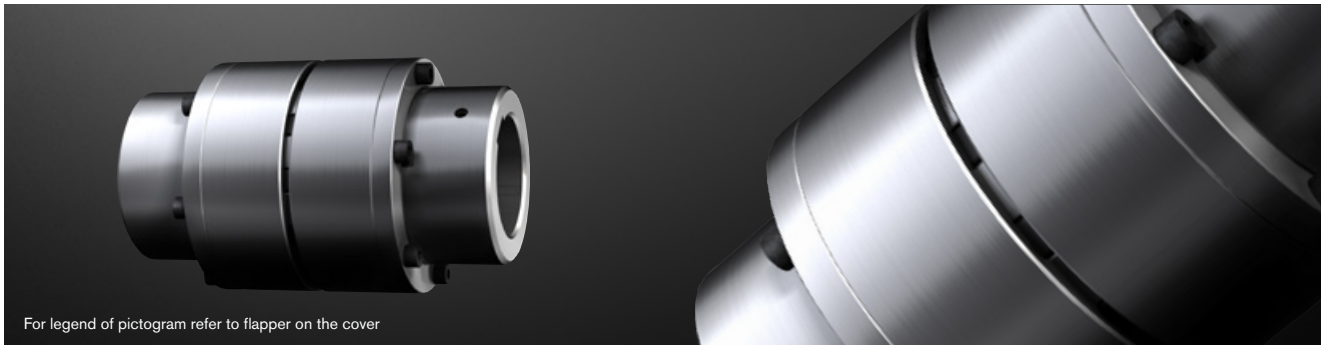

For legend of pictogram refer to flapper on the cover

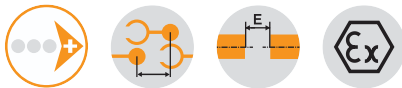

#### Components

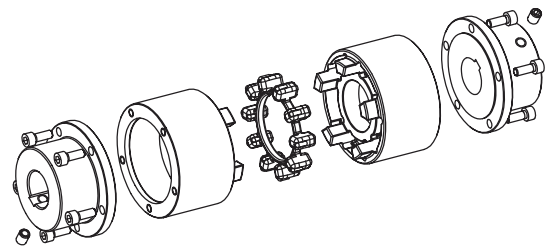
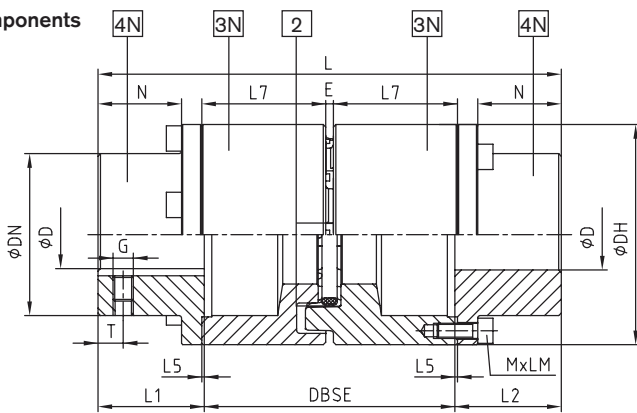

Components of type AZR:  
 2 = Elastomer ring (NBR 78 ShA)  
 3N = Driving flange (GJL)  
 4N = Coupling flange (steel)

POLY-NORM® Type AZR																		
Size	Drop-out center length DBSE [mm]	Elastomer ring <sup>1)</sup> (component 2) Torque [Nm]		Max. finish bore D <sup>2)</sup>	Dimensions [mm]										Mass moment of inertia <sup>3)</sup> [kgm <sup>2</sup> ]	Weight <sup>3)</sup> [kg]		
		TKN	TK max		General												Setscrew	
					DH	L	L2	E	DN	M	MxLM	T <sub>A</sub> [Nm]	G	T				
28	100	40	80	32	69	170	35	3	46	26	M6x18	14	M 5	7	0.0020	2.4		
32	100	60	120	38	78	170	35	4	53	26	M6x18	14	M 8	7	0.0042	3.2		
	210					0.0062									3.9			
38	100	90	180	45	87	184	42	4	62	33	M6x20	14	M 8	10	0.0048	4.3		
	224					0.0068									5.1			
42	100	150	300	50	96	190	45	4	69	35	M6x20	14	M 8	10	0.0094	5.1		
	230					0.0128									6.0			
48	100	220	440	55	106	204	52	5	78	41.5	M6x20	14	M 8	15	0.0170	6.6		
	244					0.0216									7.5			
55	100	300	600	65	118	210	55	5	88	43.5	M8x25	35	M 8	14	0.0188	9.4		
	250					0.0240									10.8			
60	140	410	820	70	129	290	60	5	97	47.5	M8x25	35	M 8	15	0.0232	12.2		
	300					0.0326									11.2			
65	100	550	1100	75	140	220	65	5	105	51.5	M8x25	35	M 10	20	0.0414	13.0		
	260					0.0504									14.6			
75	140	850	1700	90	158	230	75	5	123	60.5	M8x25	35	M 8	15	0.0564	14.0		
	310					0.0730									15.8			
85	140	1350	2700	100	182	290	85	5	139	69.5	M10x30	69	M 10	25	0.0894	17.5		
	320					0.0824									23.2			
90	180	2000	4000	110	200	330	90	5	148	73.5	M10x30	69	M 10	25	0.1008	25.6		
	400					0.1332									29.8			
100	140	2900	5800	120	224	310	100	6	165	83	M12x35	120	M 12	25	0.1570	32.1		
	360					0.1658									35.2			
100	180	2900	5800	120	224	420	100	6	165	83	M12x35	120	M 12	25	0.1812	40.7		
	450					0.2466									38.2			
100	250	2900	5800	120	224	340	100	6	165	83	M12x35	120	M 12	25	0.2880	42.2		
	430					0.3566									49.3			
100	250	2900	5800	120	224	340	100	6	165	83	M12x35	120	M 12	25	0.3988	50.0		
	450					0.4450									54.8			
100	250	2900	5800	120	224	450	100	6	165	83	M12x35	120	M 12	25	0.5465	63.2		

<sup>1)</sup> Standard material Perbunan [NBR] 78 Shore A, for selection see page 14 et seqq.

<sup>2)</sup> Bore H7 with keyway to DIN 6885 sheet 1 [JS9] and setscrew on the keyway

<sup>3)</sup> Referring to medium bore

\*For other extendable lengths (DBSE = 120/160/195/215) it is possible to combine two driving flanges 3N with various lengths. As an example: driving flanges of POLY-NORM® 85 for extendable length 140 and 250 give an extendable length DBSE of 195 mm (140 mm + 250 mm = 390 mm; 390 mm/2 = 195 mm)

Ordering example:	POLY-NORM® 42	AZR	140	Ø38	Ø42
	Coupling size	Type	Drop-out center design length L	Finish bore	Finish bore

# POLY-NORM®-M Type AFN Flexible couplings

## Three-part

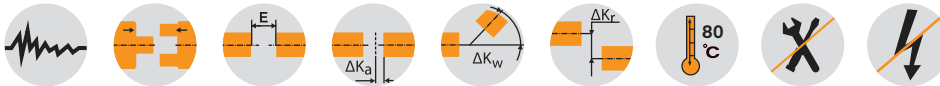
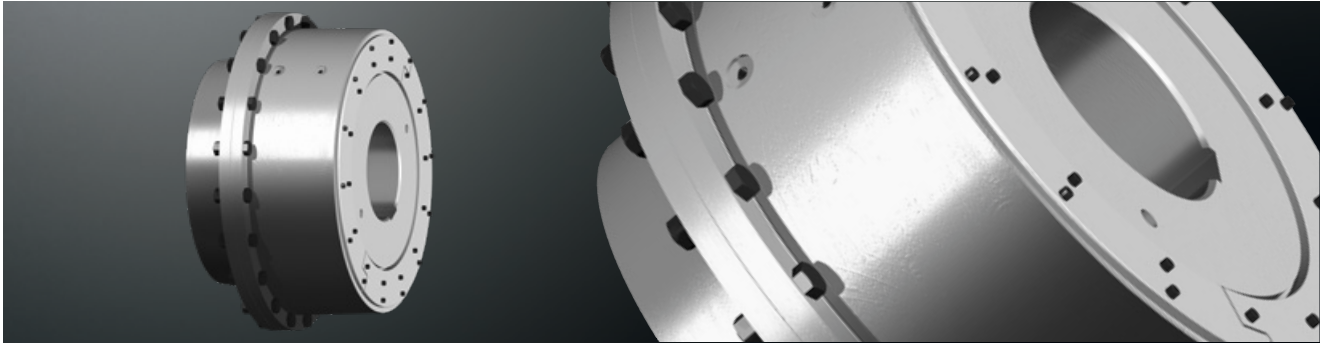

### Components

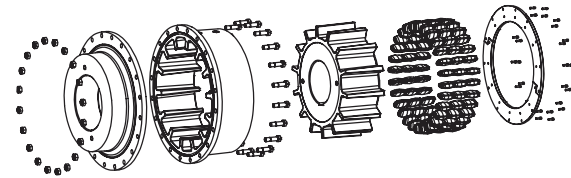
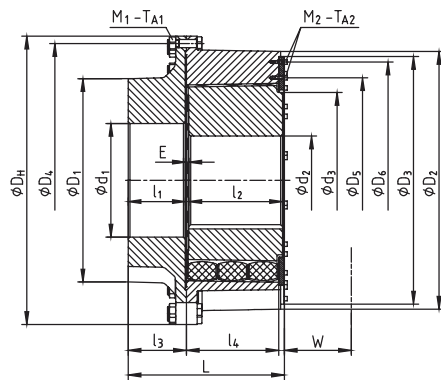

POLY-NORM®-M Type AFN																										
Size	Torque <sup>1)</sup> [kNm]		Dimensions [mm]																	Dowel screw (10.9)		Screws DIN EN ISO 4762		Approx. weight <sup>2)</sup> [kg]		
			Max. finish bore Ød		General																					
	T <sub>KN</sub>	T <sub>Kmax</sub>	d <sub>1</sub> <sup>3)</sup>	d <sub>2</sub>	L <sup>3)</sup>	l <sub>1</sub> <sup>3)</sup>	l <sub>2</sub>	l <sub>3</sub> <sup>3)</sup>	l <sub>4</sub>	DH	D <sub>1</sub>	D <sub>2</sub>	D <sub>3</sub>	D <sub>4</sub>	D <sub>5</sub>	D <sub>6</sub>	d <sub>3</sub>	E <sup>3)</sup>	W	z	M 1	TA1 [Nm]	z		M 2	TA2 [Nm]
202	100	200	350	200	425	195	215	200	218	640	500	552	530	600	360	480	300	12	150	24	M 24	970	16	M 16	290	430
252	140	280	355	250	438	208	215	213	218	720	550	635	610	680	460	570	360	12	150	30	M 24	970	18	M 16	290	590
302	200	400	380	300	464	203	247	209	255	770	600	682	660	730	510	625	430	13	175	20	M 24	970	24	M 16	290	730
402	400	800	480	400	580	224	335	230	350	1000	760	885	860	945	650	800	530	14	250	18	M 30	1950	20	M 16	290	1750
502	650	1300	650	500	654	228	407	234	360	1200	1000	1080	1050	1140	830	990	700	19	250	24	M 30	1950	24	M 16	290	2240
503	950	1900	650	500	777	228	530	234	505	1200	1000	1075	1340	1140	830	990	700	19	415	24	M 30	1950	24	M 16	290	3090
603	1250	2500	700	600	858	309	530	315	505	1350	1100	1230	1200	1295	950	1150	840	19	360	30	M 30	1950	24	M 16	290	4770
703	1500	3000	700	700	845	309	507	315	500	1560	1100	1395	1340	1480	1110	1280	950	19	360	20	M 42	3600	28	M 16	290	5150
704	2000	4000	700	700	1020	309	682	315	665	1560	1100	1390	1340	1480	1110	1280	950	19	520	20	M 42	3600	28	M 16	290	7100
803	2400	4800	1000	800	1030	406	600	416	530	1800	1600	1630	1550	1720	1250	1450	110	24	390	24	M 48	5450	28	M 24	970	9300
903	3300	6600	1000	900	982	406	541	412	550	2060	1400	1865	1800	1975	1500	1730	1300	25	390	24	M 48	5450	32	M 24	970	9800
904	4400	8800	1000	900	1376	406	857	416	745	2060	1650	1880	1800	1975	1500	1730	1300	114	550	40	M 48	5450	32	M 24	970	13800
905	5500	11000	1000	900	1377	406	857	417	920	2060	1650	1865	1800	1975	1500	1730	1300	114	715	40	M 48	5450	32	M 24	970	14800

\* Drop-out center design dimension required

<sup>1)</sup> Standard material Perbunan [NBR] 80 Shore A, electrically insulating available on request, for selection see page 18 et seq.

<sup>2)</sup> Referring to max. bore

<sup>3)</sup> Variable according to customer's request. Finish bore according to ISO fit H7, feather keyway according to DIN 6885, sheet 1 [JS9]. If requested, coupling is dynamically balanced (semi-key balancing G 6.3 with speed as specified by the customer). For circumferential speeds exceeding  $v = 20$  m/s dyn. balancing is recommended.

## Other types

Type AFN with clamping ring hub

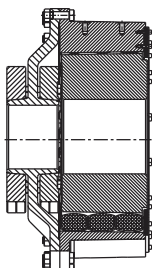

Type AFN with brake disk

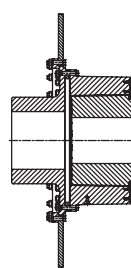

Type A with flange connection

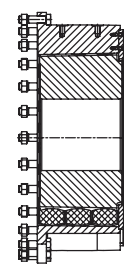

Ordering example:	POLY-NORM®-M	Type	d <sub>1</sub> Ø500	d <sub>2</sub> Ø450
	Coupling size	AFN	Finish bore	Finish bore

# REVOLLEX® KX-D

## Flexible pin & bush coupling

### Technical data

REVOLLEX® KX-D Technical data												
Size	Torque [Nm] NBR 80 ShA DIN 740 <sup>1)</sup>				Cast iron		Steel		Torsion spring stiffness C dyn. [Nm/rad]			
	Rated T <sub>KN</sub>	Max. T <sub>K max</sub>	Vibratory T <sub>KW</sub>	T <sub>K max</sub> <sup>2)</sup>	Max. speed [rpm] with v = 35 m/s	Max. bore [mm]	Max. speed [rpm] with v = 60 m/s	Max. bore [mm]	0.25 T <sub>KN</sub>	0.50 T <sub>KN</sub>	0.75 T <sub>KN</sub>	1.00 T <sub>KN</sub>
KX-D 75	4300	8600	1720	12900	–	–	4500	100	3.60x10 <sup>5</sup>	5.70x10 <sup>5</sup>	1.06x10 <sup>6</sup>	1.58x10 <sup>6</sup>
KX-D 85	5500	11000	2200	16500	–	–	4175	110	4.68x10 <sup>5</sup>	7.42x10 <sup>5</sup>	1.38x10 <sup>6</sup>	2.06x10 <sup>6</sup>
KX-D 95	7200	14400	2880	21600	–	–	3845	125	6.05x10 <sup>5</sup>	9.58x10 <sup>5</sup>	1.78x10 <sup>6</sup>	2.65x10 <sup>6</sup>
KX-D 105	9400	18800	3760	28200	2000	110	3475	130	7.88x10 <sup>5</sup>	1.25x10 <sup>6</sup>	2.32x10 <sup>6</sup>	3.46x10 <sup>6</sup>
KX-D 120	15200	30400	6080	45600	1800	125	3100	150	2.14x10 <sup>6</sup>	2.97x10 <sup>6</sup>	4.18x10 <sup>6</sup>	5.62x10 <sup>6</sup>
KX-D 135	20000	40000	8000	60000	1600	140	2725	170	2.87x10 <sup>6</sup>	3.99x10 <sup>6</sup>	5.61x10 <sup>6</sup>	7.55x10 <sup>6</sup>
KX-D 150	25000	50000	10000	75000	1450	160	2500	190	3.57x10 <sup>6</sup>	4.96x10 <sup>6</sup>	6.97x10 <sup>6</sup>	9.38x10 <sup>6</sup>
KX-D 170	41000	82000	16400	123000	1250	180	2150	220	4.63x10 <sup>6</sup>	6.66x10 <sup>6</sup>	9.92x10 <sup>6</sup>	1.64x10 <sup>7</sup>
KX-D 190	54000	108000	21600	162000	1100	205	1900	245	6.10x10 <sup>6</sup>	8.78x10 <sup>6</sup>	1.31x10 <sup>7</sup>	2.16x10 <sup>7</sup>
KX-D 215	67500	135000	27000	202500	1000	230	1725	275	7.70x10 <sup>6</sup>	1.11x10 <sup>7</sup>	1.65x10 <sup>7</sup>	2.73x10 <sup>7</sup>
KX-D 240	98000	196000	39200	294000	900	250	1550	310	8.10x10 <sup>6</sup>	1.15x10 <sup>7</sup>	1.57x10 <sup>7</sup>	2.68x10 <sup>7</sup>
KX-D 265	134000	268000	53600	402000	800	285	1375	350	1.12x10 <sup>7</sup>	1.59x10 <sup>7</sup>	2.17x10 <sup>7</sup>	3.70x10 <sup>7</sup>
KX-D 280	170000	340000	68000	510000	720	315	1225	385	1.45x10 <sup>7</sup>	2.06x10 <sup>7</sup>	2.82x10 <sup>7</sup>	4.81x10 <sup>7</sup>
KX-D 305	205000	410000	82000	615000	675	330	1150	405	1.74x10 <sup>7</sup>	2.47x10 <sup>7</sup>	3.37x10 <sup>7</sup>	5.76x10 <sup>7</sup>
KX-D 330	265000	530000	106000	795000	625	355	1075	435	2.29x10 <sup>7</sup>	3.25x10 <sup>7</sup>	4.43x10 <sup>7</sup>	7.56x10 <sup>7</sup>
KX-D 355	350000	700000	140000	1050000	575	380	975	450	4.26x10 <sup>7</sup>	8.99x10 <sup>7</sup>	1.37x10 <sup>8</sup>	1.85x10 <sup>8</sup>
KX-D 370	430000	860000	172000	1290000	535	450	900	530	4.92x10 <sup>7</sup>	1.04x10 <sup>8</sup>	1.59x10 <sup>8</sup>	2.14x10 <sup>8</sup>
KX-D 470	520000	1040000	208000	1560000	–	–	855	520	6.25x10 <sup>7</sup>	1.33x10 <sup>8</sup>	2.03x10 <sup>8</sup>	2.74x10 <sup>8</sup>
KX-D 520	810000	1620000	324000	2430000	–	–	740	According to customer specification	9.83x10 <sup>7</sup>	2.08x10 <sup>8</sup>	3.18x10 <sup>8</sup>	4.28x10 <sup>8</sup>
KX-D 590	1000000	2000000	400000	3000000	–	–	660		1.21x10 <sup>8</sup>	2.56x10 <sup>8</sup>	3.91x10 <sup>8</sup>	5.26x10 <sup>8</sup>
KX-D 650	1350000	2700000	540000	4050000	–	–	590		1.63x10 <sup>8</sup>	3.47x10 <sup>8</sup>	5.30x10 <sup>8</sup>	7.14x10 <sup>8</sup>

<sup>1)</sup> see catalogue page 15  
<sup>2)</sup> ≤ 1000 load cycles

If requested, coupling is dynamically balanced (semi-key balancing G 6.3 with speed as specified by the customer). For circumferential speeds exceeding v = 30 m/s dyn. balancing is recommended.

Axial displacement  $\Delta K_a$

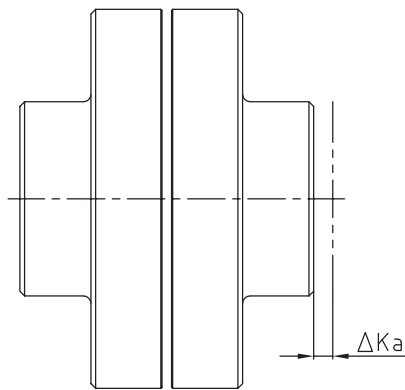

$$L_{\max./\min.} = L + \Delta K_a \text{ [mm]}$$

Radial displacement  $\Delta K_r$

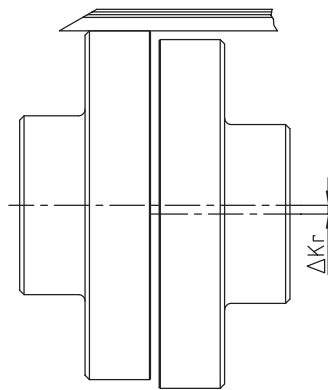

Angular displacement  $\Delta K_w$

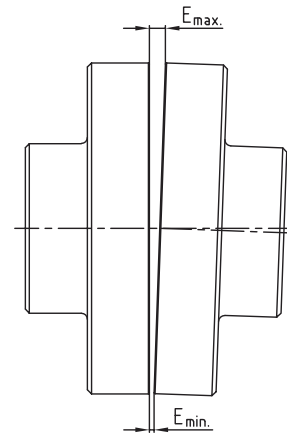

$$\Delta K_w = E_{\max.} - E_{\min.} \text{ [mm]}$$

		Displacements																				
Size (KX and KX-D)		75	85	95	105	120	135	150	170	190	215	240	265	280	305	330	355	370	470	520	590	650
Max. axial displacement $\Delta K_a$ [mm]		±1.5	±1.5	±1.5	±2	±2	±2	±2	±2.5	±2.5	±2.5	±2.5	±2.5	±2.5	±2.5	±2.5	±2.5	±2.5	±4	±4	±4	±4
Max. radial displacement $\Delta K_r$ [mm] or max. angular displacement $\Delta K_w$ [mm] with speed n	250 rpm	0.95	1.1	1.1	1.2	1.3	1.4	1.5	1.7	1.9	2.0	2.2	2.5	2.7	2.9	3.1	3.3	3.5	3.8	4.4	4.9	5.4
	500 rpm	0.70	0.80	0.80	0.9	0.9	1.0	1.1	1.2	1.3	1.4	1.6	1.7	1.9	2.0	2.2	2.3	2.5	2.8	3.1	3.5	3.8
	750 rpm	0.60	0.65	0.65	0.7	0.8	0.8	0.9	1.0	1.1	1.2	1.3	1.4	1.6	1.7	1.8	1.9	2.0	2.2	2.4	–	–
	1000 rpm	0.50	0.55	0.55	0.6	0.7	0.7	0.8	0.9	0.9	1.0	1.1	1.2	1.4	1.4	1.5	1.7	1.8	–	–	–	–
	1500 rpm	0.40	0.45	0.45	0.5	0.5	0.6	0.6	0.7	0.8	0.8	0.9	1.0	–	–	–	–	–	–	–	–	–
	2000 rpm	0.35	0.40	0.40	0.4	0.5	0.5	0.5	0.6	0.7	–	–	–	–	–	–	–	–	–	–	–	–
3000 rpm	0.30	0.35	0.35	0.4	0.4	–	–	–	–	–	–	–	–	–	–	–	–	–	–	–	–	

### Advice for assembly

The permissible displacement figures of the flexible REVOLLEX® KX couplings specified are general standard values taking into account the load of the coupling up to the rated torque T<sub>KN</sub> of the coupling and an ambient temperature of +30 °C. The displacement figures may only be used one by one, if they appear simultaneously, they must be limited in proportion. Care should be taken to maintain the distance dimension E accurately in order to allow for axial clearance of the coupling while in operation. See KTR assembly instructions, KTR standard 49410 on our homepage [www.ktr.com](http://www.ktr.com).

# REVOLEX® KX-D

## Flexible pin & bush coupling

### Material cast

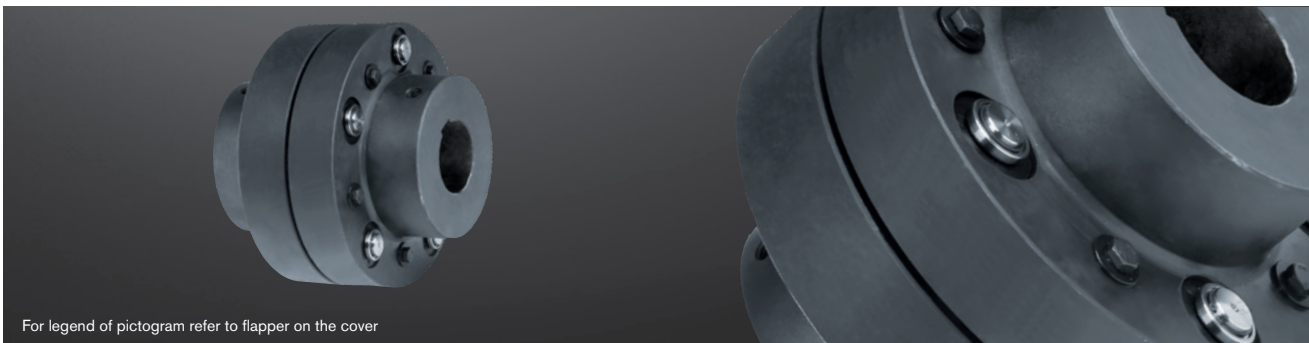

For legend of pictogram refer to flapper on the cover

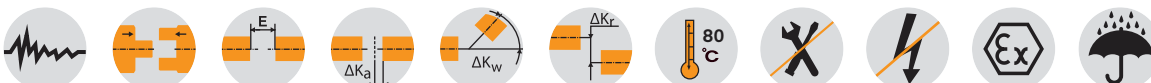

### Components

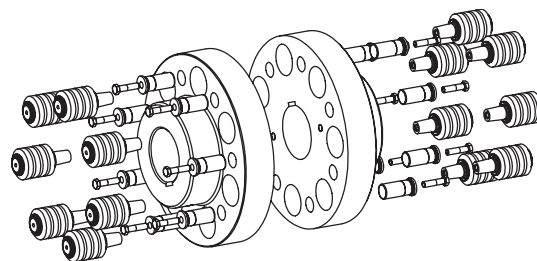
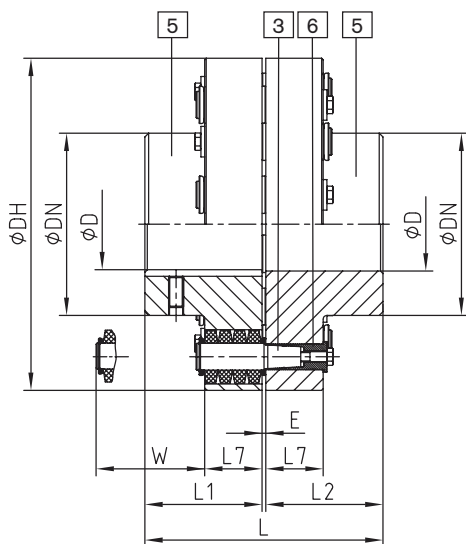

Components of type KX-D:  
 5 = Hub part 5  
 3 = Pins complete  
 6 = KX-D sleeve (hardened and corrosion-protected)

REVOLEX® Type KX-D													
Size	Torque <sup>1)</sup> [Nm]		Max. speed <sup>2)</sup> [rpm]	Finish bore (min. - max.) D	Dimensions [mm]							Mass moment of inertia <sup>3)</sup> [kgm <sup>2</sup> ]	Weight <sup>3)</sup> [kg]
	TKN	TK max			DH	DN	L	L1, L2	E	L7	W*		
KX-D 105	9400	18800	2000	38-110	330	180	237	117	3	56	76	0.888	68
KX-D 120	15200	30400	1800	45-125	370	206	270	132	6	76	100	1.833	108
KX-D 135	20000	40000	1600	75-140	419	230	300	147	6	76	100	3.079	145
KX-D 150	25000	50000	1450	85-160	457	256	336	165	6	76	100	4.477	180
KX-D 170	41000	82000	1250	95-180	533	292	382	188	6	92	130	9.944	291
KX-D 190	54000	108000	1100	110-205	597	330	428	211	6	92	130	16.096	385
KX-D 215	67500	135000	1000	125-230	660	368	480	237	6	92	130	24.851	498
KX-D 240	98000	196000	900	140-250	737	407	534	264	6	122	170	49.483	760
KX-D 265	134000	268000	800	160-285	826	457	590	292	6	122	170	79.035	997
KX-D 280	170000	340000	720	180-315	927	508	628	311	6	122	170	127.366	1301
KX-D 305	205000	410000	675	180-330	991	533	654	324	6	122	170	166.748	1509
KX-D 330	265000	530000	625	200-355	1067	572	666	330	6	122	170	222.853	1755
KX-D 355	350000	700000	575	225-380	1156	610	721	356	9	164	220	332.514	2263
KX-D 370	430000	860000	535	225-450	1250	720	773	382	9	164	220	484.695	2701

\* Drop-out center design dimension required

<sup>1)</sup> Standard material Perbunan [NBR] 80 Shore A, for selection see page 18 et seqq.

<sup>2)</sup> Higher speeds on request.

<sup>3)</sup> Referring to max. bore

Finish bore according to ISO fit H7, feather keyway according to DIN 6885, sheet 1 [JS9].

If requested, coupling is dynamically balanced (semi-key balancing G 6.3 with speed as specified by the customer). For circumferential speeds exceeding  $v = 30$  m/s dyn. balancing is recommended.

■ = Pilot bored available from stock

Ordering example:	REVOLEX® KX-D 170	GJL	Ø120	Ø150
	Type and size of coupling	Material	Finish bore	Finish bore

# REVOLEX® KX-D

## Flexible pin & bush coupling

### Material steel

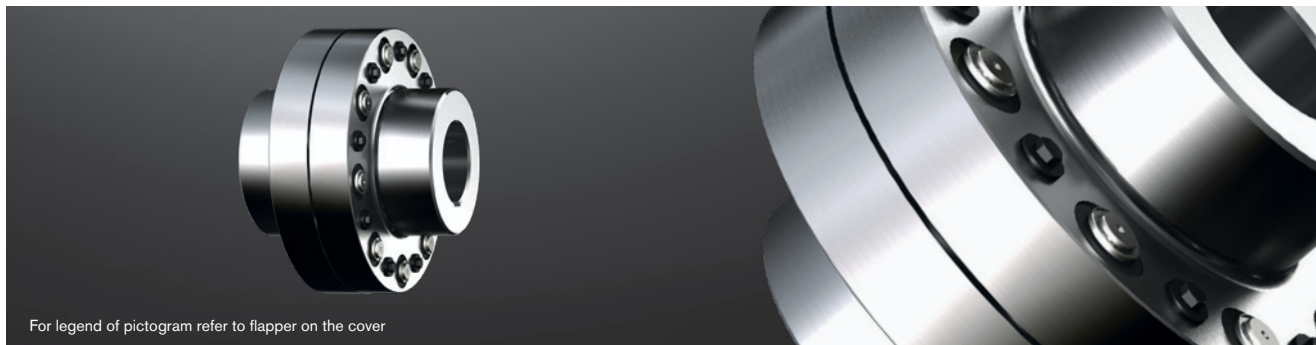

For legend of pictogram refer to flapper on the cover

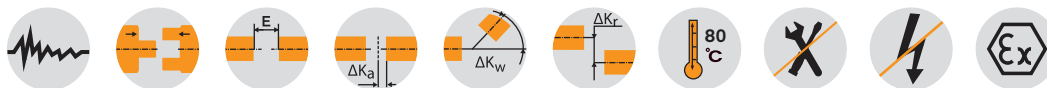

### Components

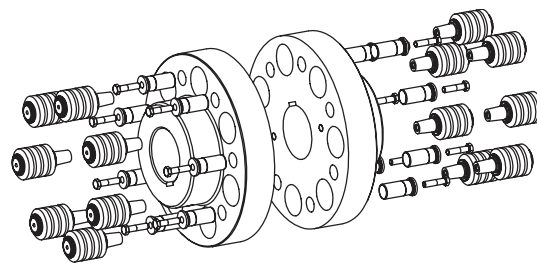
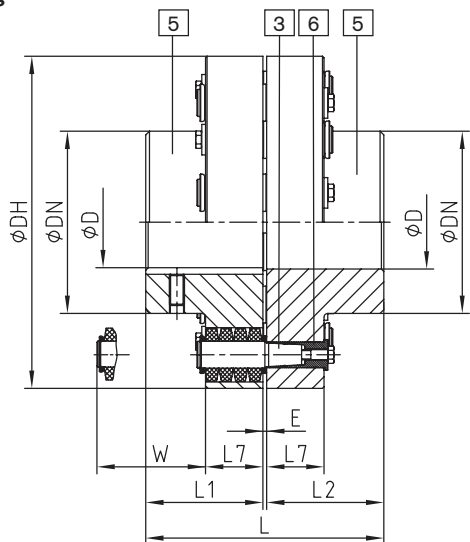

Components of type KX-D:  
5 = Hub part 5  
3 = Pins complete  
6 = KX-D sleeve (hardened and corrosion-protected)

### REVOLEX® Type KX-D

Size	Torque <sup>1)</sup> [Nm]		Max. speed <sup>2)</sup> [rpm]	Finish bore (min. - max.) D	Dimensions [mm]							Mass moment of inertia <sup>3)</sup> [kgm <sup>2</sup> ]	Weight <sup>3)</sup> [kg]
	TKN	TK max			DH	DN	L	L1, L2	E	L7	W*		
KX-D 75	4300	8600	4500	0-100	255	136	193	95	3	56	76	0.320	39
KX-D 85	5500	11000	4175	0-110	274	152	213	105	3	56	76	0.432	46
KX-D 95	7200	14400	3825	0-125	298	168	227	112	3	56	76	0.606	56
KX-D 105	9400	18800	3475	0-130	330	180	237	117	3	56	76	0.922	80
KX-D 120	15200	30400	3100	0-150	370	206	270	132	6	76	100	1.901	124
KX-D 135	20000	40000	2725	75-170	419	230	300	147	6	76	100	3.185	165
KX-D 150	25000	50000	2500	85-190	457	256	336	165	6	76	100	4.618	205
KX-D 170	41000	82000	2150	95-220	533	292	382	188	6	92	130	10.231	322
KX-D 190	54000	108000	1900	110-245	597	330	428	211	6	92	130	16.585	431
KX-D 215	67500	135000	1725	125-275	660	368	480	237	6	92	130	25.481	559
KX-D 240	98000	196000	1550	140-310	737	407	534	264	6	122	170	50.702	833
KX-D 265	134000	268000	1375	160-350	826	457	590	292	6	122	170	80.593	1099
KX-D 280	170000	340000	1225	180-385	927	508	628	311	6	122	170	130.323	1436
KX-D 305	205000	410000	1150	180-405	991	533	654	324	6	122	170	170.770	1669
KX-D 330	265000	530000	1075	200-435	1067	572	666	330	6	122	170	228.024	1954
KX-D 355	350000	700000	975	225-450	1156	610	721	356	9	164	220	415.157	2451
KX-D 370	430000	860000	900	225-530	1250	720	773	382	9	164	220	586.682	2925
KX-D 470	520000	1040000	855	240-520 <sup>4)</sup>	1340	705 <sup>4)</sup>	969 <sup>4)</sup>	480 <sup>4)</sup>	9	164	220	785.618	3631
KX-D 520	810000	1620000	760	240-520 <sup>4)</sup>	1540	780 <sup>4)</sup>	1089 <sup>4)</sup>	540 <sup>4)</sup>	9	164	220	1756.791	5155
KX-D 590	1000000	2000000	680	260-590 <sup>4)</sup>	1735	885 <sup>4)</sup>	1212 <sup>4)</sup>	600 <sup>4)</sup>	12	164	220	2928.115	6895
KX-D 650	1350000	2700000	610	280-650 <sup>4)</sup>	1935	975 <sup>4)</sup>	1332 <sup>4)</sup>	660 <sup>4)</sup>	12	164	220	4595.941	8893

<sup>1)</sup> Drop-out center dimension required <sup>2)</sup> Standard material Perbunan [NBR] 80 Shore A, for selection see page 18 et seq.

<sup>3)</sup> Higher speeds on request. <sup>4)</sup> Referring to max. bore <sup>5)</sup> Variable according to customer's requests

Finish bore according to ISO fit H7, feather keyway according to DIN 6885, sheet 1 [JS9]. If requested, coupling is dynamically balanced (semi-key balancing G 6.3 with speed as specified by the customer). For circumferential speeds exceeding v = 30 m/s dyn. balancing is recommended.

■ = Pilot bored available from stock

Ordering example:	REVOLEX® KX-D 170	steel	Ø120	Ø150
	Type and size of coupling	Material	Finish bore	Finish bore

# REVOLEX® KX-D SB

## Flexible pin & bush coupling

With brake disk

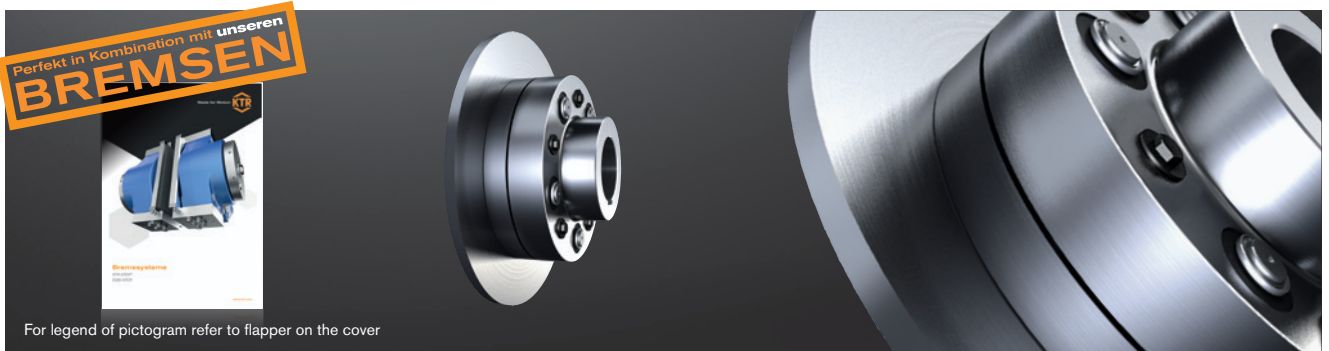

For legend of pictogram refer to flapper on the cover



REVOLEX® KX-D Type SB

Size	Torque <sup>1)</sup> [Nm] KX-D		Dimensions [mm]									
			Finish bore KX-D (min. - max.)		General							
	T <sub>KN</sub>	T <sub>K max</sub>	GJL D	Steel D	DH	DN	L	L1, L2	E	L7	L8	W*
105	9400	18800	38-110	0-130	330	180	237	117	3	56	55	76
120	15200	30400	50-125	0-150	370	206	270	132	6	76	75	100
135	20000	40000	70-140	70-170	419	230	300	147	6	76	75	100
150	25000	50000	82-160	82-190	457	256	336	165	6	76	75	100
170	41000	82000	95-180	95-220	533	292	382	188	6	92	91	130
190	54000	108000	110-205	110-245	597	330	428	211	6	92	91	130
215	67500	135000	125-230	125-275	660	368	480	237	6	92	91	145
240	98000	196000	140-250	140-310	737	407	534	264	6	122	121	167

Type SB brake disk

Size	Dimensions [mm]			Weight [kg]	Mass moment of inertia [kgm <sup>2</sup> ]
	DA2 <sup>2)</sup>	B3	AS		
105	560	30	47	45.8	2.139
	630	30	47	61.3	3.508
120	560	30	42	42.3	2.063
	630	30	42	57.7	3.431
135	630	30	57	54.7	3.313
	710	30	57	74.5	5.546
150	710	30	75	71.0	5.414
	800	30	75	96.2	9.010
170	710	30	82	61.8	4.963
	800	30	82	86.9	8.557
190	800	30	105	80.3	8.068
	900	30	105	111.8	13.765
215	800	30	131	73.2	7.462
	900	30	131	104.7	13.161
240	1000	30	131	139.8	21.112
	800	30	128	60.4	6.568
240	900	30	128	91.8	12.265
	1000	30	128	126.9	20.214

\* Drop-out center design dimension required

<sup>1)</sup> Standard material Perbunan [NBR] 80 Shore A, for selection see page 18 et seqq.

<sup>2)</sup> Maximum circumferential speed  $v = 60$  m/s referring to the maximum outside diameter.

Finish bore according to ISO fit H7, feather keyway according to DIN 6885, sheet 1 [JS9].

If requested, coupling is dynamically balanced (semi-key balancing G 6.3 with speed as specified by the customer). For circumferential speeds exceeding  $v = 30$  m/s dynamic balancing is recommended (referring to outside diameter  $\varnothing A$ ).

Ordering example:

REVOLEX® KX 170	SB	Ø710 x 30	1 - Ø120	2SB - Ø150
Type and size of coupling	Type	Brake disk	Finish bore	Finish bore

Components

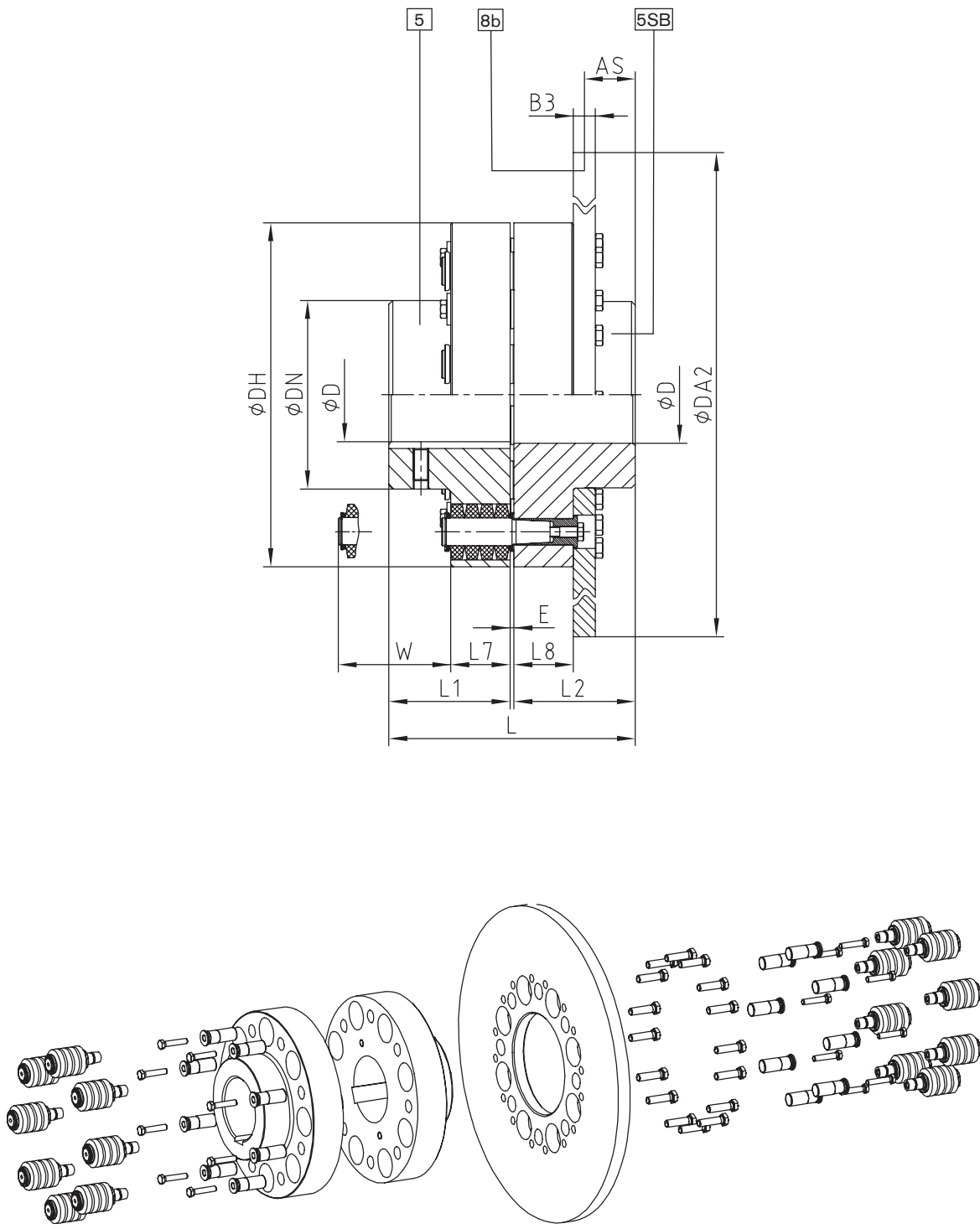

# REVOLEX® KX-D with KTR 650 clamping set

## Flexible pin & bush coupling

### Material steel

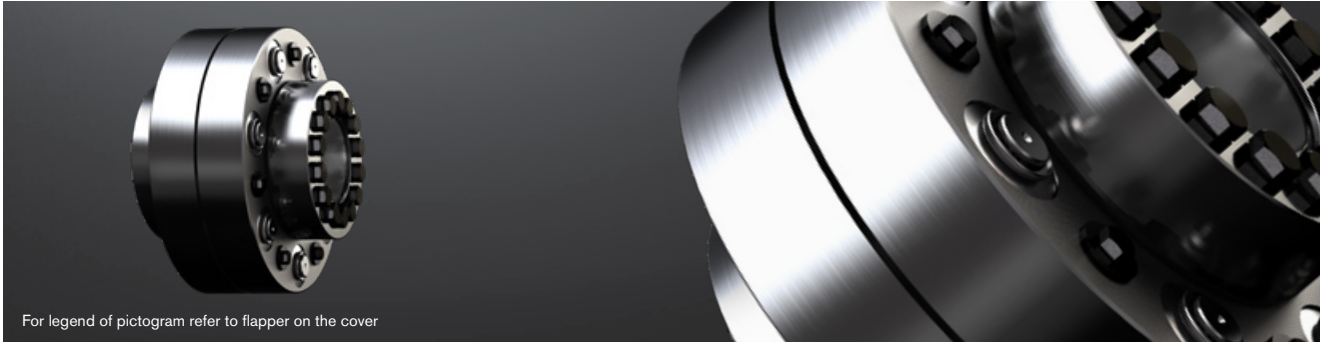

For legend of pictogram refer to flapper on the cover

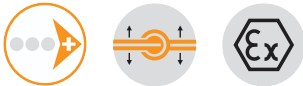

REVOLEX® KX-D						CLAMPEX® KTR 650						
Size	DH	L1, L2	L7	E	TKN <sup>1)</sup> [Nm]	Dimensions [mm]		Screws				Transmittable torque T [Nm]
						Max. poss. Size d x D	TK	Size	Length	Number	T <sub>A</sub> [Nm]	
105	330	123	56	3	9400	100 x 197	156	M 16	75	14	250	18800
120	370	149	76	6	15200	110 x 215	166	M 20	90	10	490	22400
135	419	157	76	6	20000	120 x 230	186	M 20	90	14	490	35200
150	457	168	76	6	25000	140 x 290	216	M 20	100	16	490	46700
170	533	205	92	6	41000	180 x 340	276	M 24	130	16	840	85800
190	597	214	92	6	54000	220 x 405	320	M 27	140	18	1250	148600
215	660	232	92	6	67500	260 x 460	356	M 27	160	21	1250	192900
240	737	254	122	6	98000	240 x 430	340	M 27	150	20	1250	175400
265	826	280	122	6	134000	320 x 550	402	M 27	180	24	1250	248900
280	927	313	122	6	170000	390 x 630	486	M 30	200	24	1700	368300
305	991	321	122	6	205000	440 x 700	534	M 30	220	28	1700	472100
330	1067	321	122	6	265000	440 x 700	534	M 30	220	28	1700	472100

<sup>1)</sup> Standard material Perbunan [NBR] 80 Shore A, for selection see page 18 et seqq.

If requested, coupling is dynamically balanced (semi-key balancing G 6.3 with speed as specified by the customer). For circumferential speeds exceeding  $v = 30$  m/s dynamic balancing is recommended (referring to outside diameter ØA).

CLAMPEX® KTR 650							
D <sub>CLAMPEX</sub> x DH-CLAMPEX	Dimensions [mm]		Screws				Transmittable torque T [Nm]
	LC	TK	Size	Length	Number	T <sub>A</sub> [Nm]	
100 x 215	73	166	M 20	90	10	490	22400
110 x 230	81	186	M 20	90	14	490	33600
120 x 290	92	216	M 20	100	16	490	42100
130 x 290	92	216	M 20	100	16	490	46700
140 x 320	102	234	M 24	110	14	840	63600
150 x 320	102	234	M 24	110	14	840	63600
160 x 340	113	276	M 24	130	16	840	85800
170 x 340	113	276	M 24	130	16	840	85800
180 x 370	117	290	M 27	140	16	1,250	119700
190 x 370	117	290	M 27	140	16	1,250	119700
200 x 405	122	320	M 27	140	18	1,250	148600
210 x 405	122	320	M 27	140	18	1,250	148600
220 x 430	132	340	M 27	150	20	1,250	175400
230 x 430	132	340	M 27	150	20	1,250	175400
240 x 460	140	356	M 27	160	21	1,250	192900
250 x 460	140	356	M 27	160	21	1,250	192900
260 x 485	147	360	M 27	180	21	1,250	195000
270 x 485	147	360	M 27	180	21	1,250	195000
280 x 520	150	380	M 27	180	21	1,250	205900
290 x 520	150	380	M 27	180	21	1,250	205900
300 x 550	158	402	M 27	180	24	1,250	248900
310 x 550	158	402	M 27	180	24	1,250	248900
320 x 570	164	424	M 27	180	24	1,250	262500
330 x 570	164	424	M 27	180	24	1,250	262500
340 x 610	171	454	M 30	190	24	1,700	344000
350 x 610	171	454	M 30	190	24	1,700	344000

Ordering example:

REVOLEX® KX-D 170	Steel	KTR 650 Ø120	KTR 650 Ø150
Type and size of coupling	Material	KTR 650 for shaft diameter	KTR 650 for shaft diameter

Components

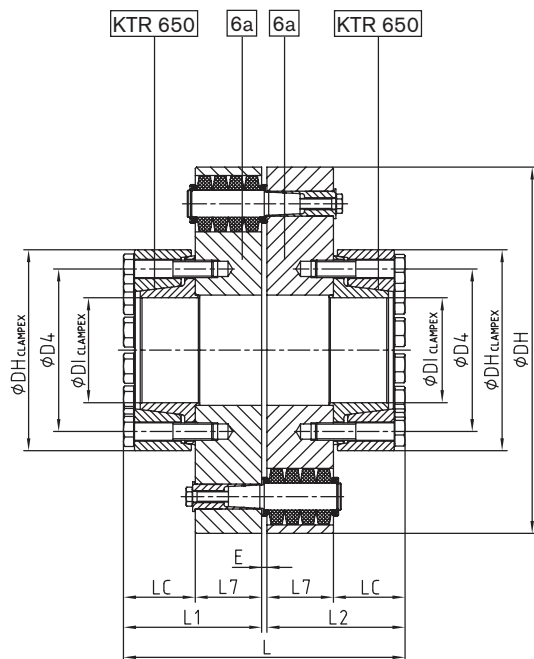

Other types

Type AB with limitation of axial backlash

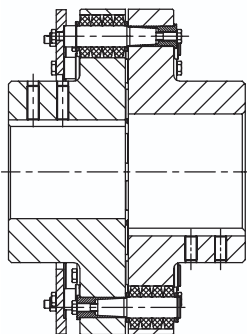

Intermediate shaft type with RADEX®-N

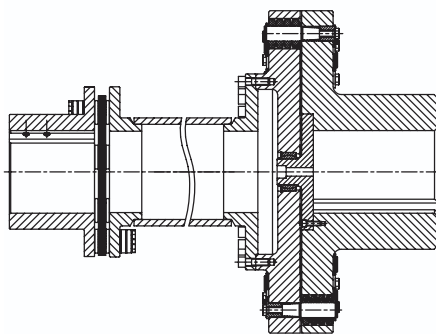

Backlash-free type

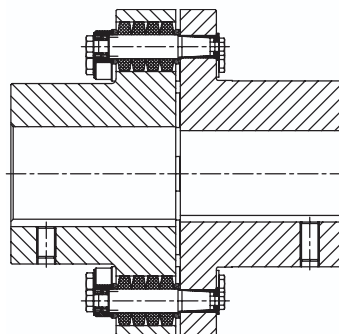

Type KX-D SD shiftable with shiftable linkage

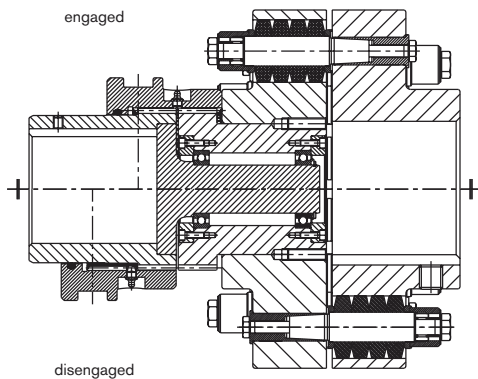

Type KX-D with cardan shaft connection

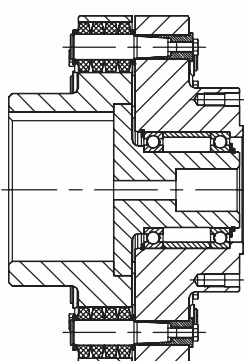

Type KX-D with KTR-SI FRE

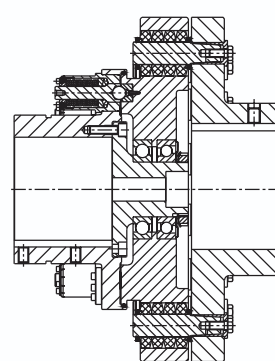

# REVOLEX® KX-D

## Flexible pin & bush coupling

### Technical data of pins

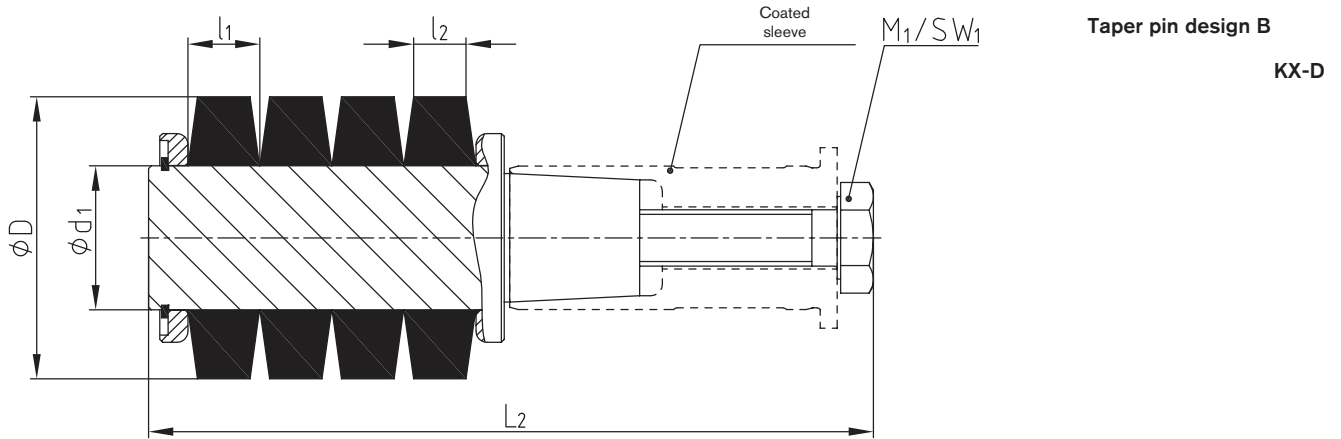

#### Technical data

Size	Pin		Elastomer ring NBR 80 Shore A			Pin		Screw DIN EN ISO 4014/4017		Tightening torque $T_A$ [Nm]
	Size	Number	D	l1	l2	d1	L2	M 1	SW1	
75		10								
85	3	12	50	12.7	9.3	25.5	129	M 10	16	67
95		14								
105		16								
120		14								
135	4	16	63	17.8	12.5	30.7	178	M 12	18	115
150		18								
170		14								
190	5	16	85.5	23.1	15.3	43.2	220	M 16	24	290
215		18								
240		14								
265		16								
280	6	18	113.7	30.5	20.3	58.4	290	M 24	36	970
305		20								
330		24								
355		16								
370	7	20	150	41.5	29	75	393	M 30	46	1350
470		22								
520		18								
590	8	20	209.5	55.5	35	95	523	M 36	55	2250
650		24								

#### General information on the elastomer rings

Material	Perbunan [NBR]	Natural rubber [NR]	Perbunan [NBR]
Hardness	80 Shore A	80 Shore A	80 Shore A
Permanent temperature range [°C]	-30 to +80	-50 to +70	-30 to +80
Max. temperature (short time) [°C]	-50 to +120	-	-
Colour	black	black	blue
Operating range	STANDARD	sub-zero temperatures	electrically insulating and backlash-free, e. g. cableway drives
			

## Assembly/disassembly

ROTEX®

Flexible jaw and  
pin & bush couplings

ROFLEX®

POLY-NORM®

POLY-NORM®-M

REVOLEX®

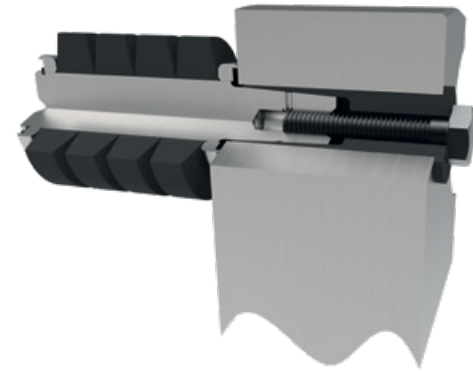

① Unscrew screw

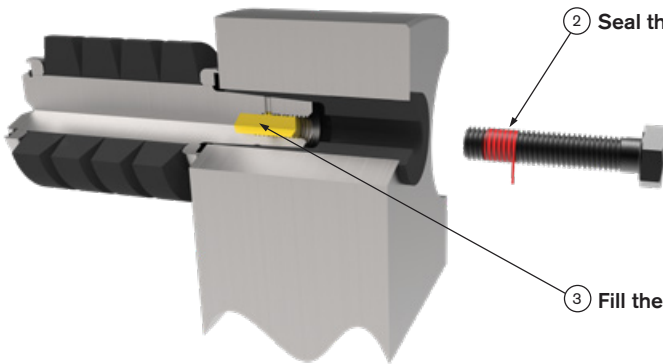

② Seal the screw in this area with sealing tape (e. g. Loctite® 55)

③ Fill the tapped hole with standard grease for 3/4

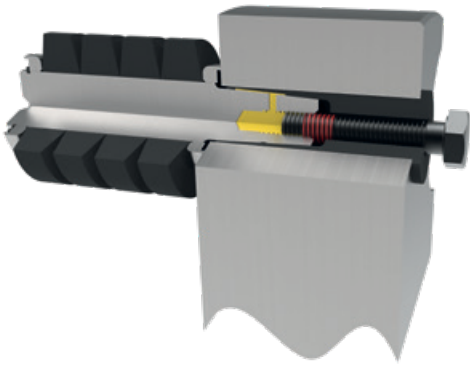

④ Screw in the screw (no special tools required)

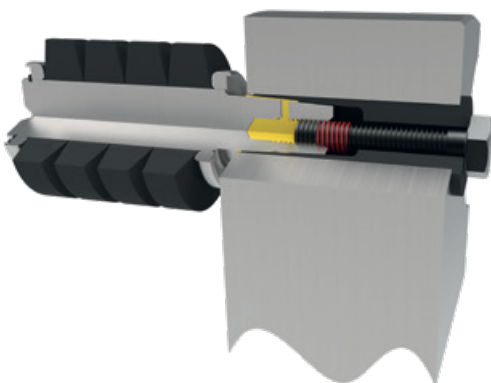

⑤ The hydraulic pressure is transmitted to the pin pressing it out of the taper fit.



# Gear couplings

Types and operating description 84

## BoWex®

Technical data	86
Displacements	87
Cylindrical and taper bores and selection of standard IEC motors	88
Type junior and junior M plug-in couplings made of nylon	89
Type M, type I and type M...C with explosion protection	90
Type AS and type Spec.-I	92
Type SG, type SSR and type Spec.-I/CD	93
Type SD / SD-D	94
Type SD1 with slip ring and shiftable linkage	96
Type GT	98
Type M made of corrosion-resistant materials	99
Taper bores	100
Spline hubs and inch bores	101

## GEARex®

Type FA, FB and FAB	102
Type DA, DB and DAB	104
Type FBR and DBR	106
Type FH and DH	108
Type SD	110
Type FR and DR	112
Displacements	114
Flange dimensions in accordance with AGMA 9008-B00	115

BoWex®



GEARex®



# GEAR COUPLINGS

## TYPES AND OPERATING DESCRIPTION

### Properties of gear couplings

		
<b>Product</b>	<b>BoWex®</b>	<b>GEARex®</b>
Type	Curved-tooth gear coupling*	All-steel gear coupling
<b>Features</b>		
AGMA		●
Torsionally stiff	●	●
Damping vibrations	HEW Compact	
Maintenance-free	●	
Axial plug-in	●	
Compensating for misalignment	●	●
Fail-safe		●
Shear type	●	
Electrical insulation	●	○
<b>Special features</b>		
Variation	very high extensive basic programme available from stock while customised solutions can be realized	medium extensive basic programme available from stock while customised solutions can be realized
Applications / core industries	pump drives, general mechanical engineering & hydraulics, food industry, ...	heavy engineering, transport, logistics, cement industry, ...
<b>Torque range <math>T_{KN}</math> [Nm]</b>		
Max.	2,500	2,750,000
<b>Speed range <math>n</math> [rpm] *</b>		
Max.	14,000	8,500
<b>Hub materials available</b>		
Nylon	●	
Quality steel (C45)	Size 65 - 125	up to size 85
Alloyed Q & T steel (42CrMo4V)		from size 90
Sintered steel » subject to mould	Size 14 - 65	
Stainless steel	●	
Other special materials possible	●	●
Corrosion-protected types	○	○
<b>Sleeve (standard and special)</b>		
Material	Polyamide/polyamide with carbon fibre reinforcement	-
<b>Temperature range [°C] min./max.</b>		
Standard	-40/+100	-20/+80
Special	-50/+120	-40/+120

- ≈ Standard
- ≈ On request
- \* ≈ Depending on size



In KTR's Power Transmission Center the performance of our products is subjected to testing. Great emphasis is put on quality assurance.

# GEAR COUPLINGS

## TYPES AND OPERATING DESCRIPTION

### Product finder of gear couplings

Product	BoWex®	GEARex®
Type	Curved-tooth gear coupling*	All-steel gear coupling
<b>Geometries</b>		
Design	compact	short/compact
Mass moment of inertia	low	medium
Shaft distance dimension	very low	very low
<b>Types (extract)</b>		
Shiftable coupling type	SD, SD-1, SD-D, SD-D3	SD
Flange type	-	FA, FB, FAB, FH, FR, FBR
Cover type	-	DA, DB, DAB, DH, DR, DBR
Suitable for horizontal assembly	Standard	Standard
Suitable for vertical assembly	Standard	VD
Sleeve can be radially disassembled » without displacing driving/driven side	GT	-
Intermediate shaft types » bridging larger shaft distances	ZR	FH, DH
Single-cardanic	-	FR, DR
Double-cardanic » compensating for big displacements » lower restoring forces	Standard	Standard
<b>Certifications/type examinations</b>		
ATEX 	•	•
DNV/GL 	•	•
Bureau Veritas 	•	
ABS 		•
GOST R/GOST TR 	•	
Curved-tooth gear principle 	•	•

• ≈ Standard

### Details on spline

Hub with crowned spline (BoWex® and GEARex®)

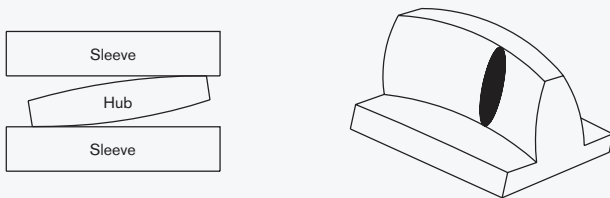

Based on the operating principle of the renowned crowned gear technology, edge pressure in the spline is avoided with angular and radial displacements.

#### BoWex®:

The smooth and hard surface of the BoWex® sleeve (crystalline structure) and the high thermal stability and resistance to lubricants, fuels, hydraulic liquids, solvents, etc. make polyamide an ideal material for components stressed by sliding, particularly for coupling manufacture.

#### GEARex®:

In order to ensure regular and controlled lubrication in assembled condition, two connections for hydraulics are arranged opposite to each other radially on each coupling sleeve. Accordingly a complete GEARex® coupling has four connections offset to each other by 90°.

Hub with spur toothing

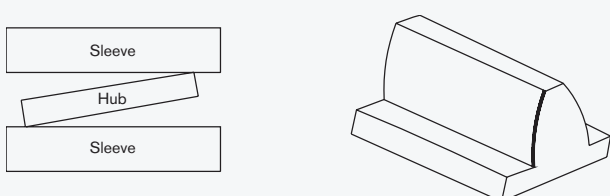

# BoWex® Curved-tooth gear coupling®

## Technical data

Power, torque and speed						
Type and size		Torque [Nm]			Max. speed [rpm]	
		T <sub>KN</sub>	T <sub>K max.</sub>	T <sub>KW</sub>		
Type plug-in coupling/ junior M	junior 14 / M-14	5	10	2.5	6000	
	junior 19 / M-19	8	16	4		
	junior 24 / M-24	12	24	6		
Type M   AS Spec.-I SG SSR	14	10	30	5	14000	
	19	16	48	8	11800	
	24	20	60	10	10600	
	28	45	135	23	8500	
	32	60	180	30	7500	
	38	80	240	40	6700	
	42	100	300	50	6000	
	45 / 48	140	420	70	5600	
	65	380	1140	190	4000	
	80	700	2100	350	3150	
	100	1200	3600	600	3000	
	125	2500	7500	1250	2120	
Type M...C GT	14	15	45	7.5	14000	
	19	24	72	12	11800	
	24	30	90	15	10600	
	28	70	210	35	8500	
	32	90	270	45	7500	
	38	120	360	60	6700	
	48	200	600	100	5600	
	65	560	1680	280	4000	
	80	1000	3000	500	3150	

## Setscrews

Thread dimensions for setscrews, BoWex® coupling hubs with cylindrical bore.

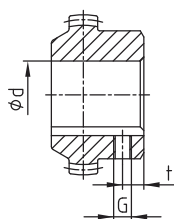

Position of the thread for setscrew BoWex® M-14 to M-24 opposite the keyway

BoWex® M-28 to I-125 on the keyway

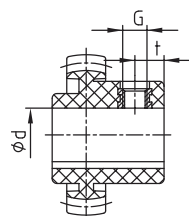

Position of thread with BoWex® junior plug-in coupling and junior M coupling

BoWex® coupling hubs							
Size Dimensions	14 19 24	28 32 38	42 45 48	65	80	100	125
Thread G	M5	M8	M10	M10	M12	M16	
Distance t	6	10	15 <sup>1)</sup> 20	20	30	40	
Tightening torque T <sub>A</sub> [Nm]	2	10	17	17	40	80	

BoWex® junior coupling hubs			
Size Dimensions	14	19	24
Thread G	M5	M5	M5
Hub 1b - Distance t	6	6	6
Plug-in sleeve 2b - Distance t	8	10	10
Tightening torque T <sub>A</sub> [Nm]	1.4	1.4	1.4

<sup>1)</sup> Length of hub 55 mm t = 15 mm, 70 mm t = 20 mm

# BoWex® Curved-tooth gear coupling®

## Types of hubs

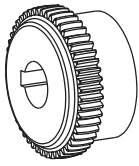

**Type 1.0 hub with feather keyway and setscrew**

Positive-locking power transmission, permissible torque depending on the permissible surface pressure. Not suitable for backlash-free power transmission with heavily reversing operation.

**Type 1.1 hub without feather keyway, with setscrew**

Non-positive torque transmission for crimp connections and adhesive bonds. (No ATEX approval)

**Type 1.3 hub with spline bore (see page 101)**

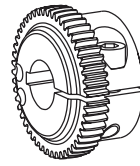

**Type 2.0 clamping hub single slot without feather keyway**

Frictionally engaged, backlash-free shaft-hub-connection. Transmittable torques depending on bore diameter.

**Type 2.1 clamping hub single slot with feather keyway**

Positive-locking power transmission with additional friction fit. The friction fit avoids resp. reduces reverse backlash. Surface pressure of the keyway connection is reduced.

**Type 2.3 clamping hub with spline bore (see page 101)**

Other hub types on request.

## Displacements

BoWex® couplings are double-cardanic compensating for axial, radial and angular shaft displacements in addition to transmitting the power so that damage on the driving or driven machine is prevented.

**Axial displacement**

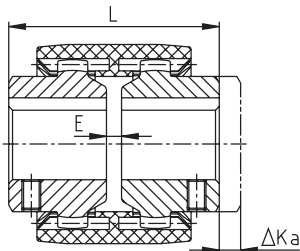

**Radial displacement**

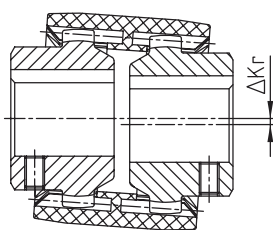

**Angular displacement**

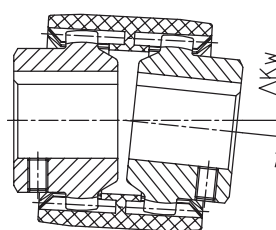

**Radial and angular displacement**

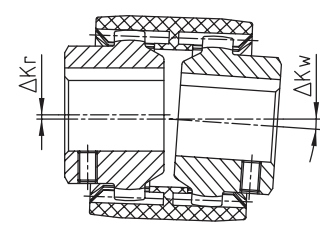

### Displacements – type junior couplings

BoWex® size	Type junior plug-in coupling			Type junior M		
	14	19	24	14	19	24
Max. axial displacement $\Delta K_a$ [mm]	± 1	± 1	± 1	± 1	± 1	± 1
Max. radial displacement with $n=1500$ rpm $\Delta K_r$ [mm]	± 0.1	± 0.1	± 0.1	± 0.3	± 0.3	± 0.4
Max. radial displacement with $n=3000$ rpm $\Delta K_r$ [mm]	± 0.1	± 0.1	± 0.1	± 0.3	± 0.3	± 0.4
Max. angular displacement with $n=1500$ rpm $\Delta K_w$ [degree]	± 1.0	± 1.0	± 0.9	± 1.0	± 1.0	± 0.9
Max. angular displacement with $n=3000$ rpm $\Delta K_w$ [degree]	± 0.7	± 0.7	± 0.6	± 0.7	± 0.7	± 0.6

### Displacements – type M, M..C, I, AS, Spec.-I, SG and SSR

BoWex® size	14	19	24	28	32	38	42	48	65	80	100	125
Max. axial displacement $\Delta K_a$ [mm]	± 1	± 1	± 1	± 1	± 1	± 1	± 1	± 1	± 1	± 1	± 1	± 1
Max. radial displacement with $n=1500$ rpm $\Delta K_r$ [mm]	± 0.30	± 0.30	± 0.35	± 0.35	± 0.35	± 0.40	± 0.40	± 0.40	± 0.45	± 0.45	± 0.45	± 0.45
Max. radial displacement with $n=3000$ rpm $\Delta K_r$ [mm]	± 0.20	± 0.20	± 0.23	± 0.23	± 0.23	± 0.25	± 0.25	± 0.25	± 0.28	± 0.28	± 0.28	± 0.28
Max. angular displacement with $n=1500$ rpm $\Delta K_w$ [degree]	± 1.0	± 1.0	± 0.9	± 0.9	± 0.9	± 0.9	± 0.9	± 0.9	± 0.7	± 0.6	± 0.6	± 0.4
Max. angular displacement with $n=3000$ rpm $\Delta K_w$ [degree]	± 0.7	± 0.7	± 0.6	± 0.6	± 0.6	± 0.6	± 0.6	± 0.6	± 0.5	± 0.4	± 0.4	± 0.3

### Displacements – type GT

### Displacements – type HEW Compact

BoWex® size	Displacements – type GT				Displacements – type HEW Compact														
	28	38	48	65	42-130			65-180			80-225			100-305			125-365		
Elastomer hardness [Shore A]					T50	T65	T70	T50	T65	T70	T50	T65	T70	T50	T65	T70	T40	T52	T65
Max. axial displacement $\Delta K_a$ [mm]	± 1	± 1	± 1	± 1	± 2			± 2			± 2			± 2			± 2		
Max. radial displacement with $n=1500$ rpm $\Delta K_r$ [mm]	± 1	± 1	± 1.4	± 1.4	± 1.1	± 1	± 0.5	± 1.6	± 1.5	± 0.7	± 1.8	± 1.7	± 0.8	± 2.2	± 2	± 1	± 2.5	± 2.3	± 1.1
Max. radial displacement with $n=3000$ rpm $\Delta K_r$ [mm]	± 0.6	± 0.6	± 1	± 1	± 0.55	± 0.5	± 0.25	± 0.8	± 0.75	± 0.35	± 0.9	± 0.85	± 0.9	± 1.1	± 1	± 0.5	± 1.25	± 1.15	± 0.55
Max. angular displacement with $n=1500$ rpm $\Delta K_w$ [degree]	± 1	± 1	± 0.9	± 0.9	± 1	± 0.75	± 0.5	± 1	± 0.75	± 0.5	± 1	± 0.75	± 0.4	± 1	± 0.75	± 0.5	± 1	± 0.75	± 0.5
Max. angular displacement with $n=3000$ rpm $\Delta K_w$ [degree]	± 0.7	± 0.7	± 0.6	± 0.6	± 0.5	± 0.4	± 0.25	± 0.5	± 0.4	± 0.25	± 0.5	± 0.4	± 0.5	± 0.5	± 0.25	± 0.25	± 0.5	± 0.4	± 0.25

The permissible displacement figures of the BoWex® couplings specified are general standard values taking into account the load of the coupling up to the rated torque  $T_{KN}$  of the coupling. With different operating conditions please order our data sheet for displacements of BoWex® KTR-N 20140.

The displacement figures may only be used one by one, if they appear simultaneously, they must be limited in proportion. Care should be taken to maintain the distance dimension E accurately in order to allow for axial clearance of the coupling while in operation. Detailed mounting instructions are shown on our homepage [www.ktr.com](http://www.ktr.com).

# BoWex® Curved-tooth gear coupling®

For cylindrical bores, taper/inch bores see selection of standard IEC motors

Stock programme of cylindrical finish bores [mm] H7 feather keyway acc. to DIN 6885 sheet 1 [JS9] and setscrew																														
BoWex® Size	un/pilot bored	Ø8	Ø10	Ø11	Ø12	Ø14	Ø15	Ø16	Ø17	Ø18	Ø19	Ø20	Ø22	Ø24	Ø25	Ø28	Ø30	Ø32	Ø35	Ø38	Ø40	Ø42	Ø45	Ø48	Ø50	Ø55	Ø60	Ø65	Ø70	Ø75
14	●■	●	●	●	●	●	●																							
19	●■		●	●	●	●	●	●	●	●	●■	●																		
24	●■		●	●	●	●■	●	●	●	●	●■	●■	●	●■	●															
28	●■			●	●	●	●	●	●	●	●■	●	●	●	●	●■														
32	●■							●		●	●	●	●	●	●	●	●	●	●	●	●									
38	●■							●		●	●	●	●	●	●	●	●	●	●	●■										
42	●■									●	●	●	●	●	●	●	●	●	●	●	●	●	●	●	●					
48	●■											●			●	●	●	●	●	●	●	●■	●	●■	●■					
65	●■														●	●	●	●	●	●	●	●■	●■	●■	●■	●■	●■	●■	●■	
80	●																													●

● Standard length      ■ Standard lengthened

taper and inch bores																														
Code d +0.05 b JS9 t +0.2	Taper 1:5					Taper 1:8					Inch bores																			
	A-10 9.85 2	B-17 16.85 3	C-20 19.85 4	D-25 24.85 5	E-30 29.85 6	N/1 9.7 2.4	N1d 14 3	N/2 17.28 3.2	N/2a 17.28 4	N/3 22 3.99	Ta 12.7 3.17 14.3	DNC 13.45 3.17 14.9	Ed 15.87 4.75 18.1	A 19.05 4.78 21.3	G 22.22 4.75 24.7	F 22.22 6.38 25.2	Bs 25.38 6.37 28.3	Hs 25.4 6.35 28.7	K 31.75 7.93 35.4											
14	●																			●										
19		●																		●										
24	●	●																		●	●									
28	●	●						●	●											●										
32		●																			●									
38		●																			●									
42		●		●																	●	●								
48																														
65																														●

Other dimensions on request.  
● Standard length

BoWex® couplings for standard IEC motors, protection class IP 54/IP 55											
A. C. motor Size	Engine power with 50 Hz n = 3000 [rpm]			Engine power with 50 Hz n = 1500 [rpm]			Engine power with 50 Hz n = 1000 [rpm]			Cylindrical shaft ends d x l [mm]  3000 ≤ 1500	
	kW	T [Nm]	BoWex® coupling	kW	T [Nm]	BoWex® coupling	kW	T [Nm]	BoWex® coupling		
56	0.09	0.32		0.06	0.43		0.037	0.43		9 x 20	
	0.12	0.41		0.09	0.64		0.045	0.52			
63	0.18	0.62	14	0.12	0.88	14	0.06	0.72	14	11 x 23	
	0.25	0.86		0.18	1.3		0.09	1.1			
71	0.37	1.3		0.25	1.8		0.18	2.0		14 x 30	
	0.55	1.9		0.37	2.5		0.25	2.7			
80	0.75	2.5	19	0.55	3.7	19	0.37	3.9	19	19 x 40	
	1.1	3.7		0.75	5.1		0.55	5.8			
90 S	1.5	5.0	24	1.1	7.5	24	0.75	8.0	24	24 x 50	
90 L	2.2	7.4		1.5	10		1.1	12			
100 L	3	9.8	28	2.2	15	28	1.5	15	28	28 x 60	
				3	20		2.2	22			
112 M	4	13		4	27		2.2	22			
132 S	5.5	18	38	5.5	36	38	3	30	38	38 x 80	
	7.5	25					4	40			5.5
132 M				7.5	49						
160 M	11	36	42	11	72	42	7.5	75	42	42 x 110	
	15	49									
160 L	18.5	60		15	98		11	108			
180 M	22	71	48	18.5	121	48			48	48 x 110	
	180 L			22	144		15	148			
200 L	30	97		30	196		18.5	181		55 x 110	
	37	120					22	215			
225 S			65	37	240	65			65	55 x 110	60 x 140
	225 M	45		145	45		292	30			
250 M	55	177		55	356		37	361		60 x 140	65 x 140
280 S	75	241	80	75	484	80	45	438	80		75 x 140
	280 M	90		289	90		581	55			
315 S	110	353		110	707		75	727			
	315 M	132		423	132		849	90			
315 L	160	513	80	160	1030	100	110	1070	100	65 x 140	80 x 170
	200	641		200	1290		132	1280			
315	250	801	100	250	1610	125	200	1930	125		85 x 170
	315	1010		315	2020		250	2420			
355	355	1140	125	355	2280					75 x 140	95 x 170
	400	1280		400	2560		315	3040			

Torque T<sup>^</sup> = rated torque according to Siemens catalogue.

# BoWex® junior and junior M Curved-tooth gear coupling®

## Plug-in coupling made of nylon (two-part and three-part)

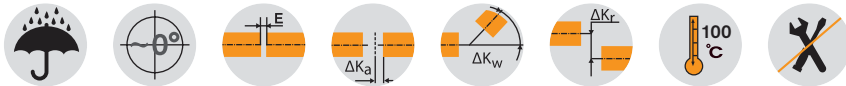
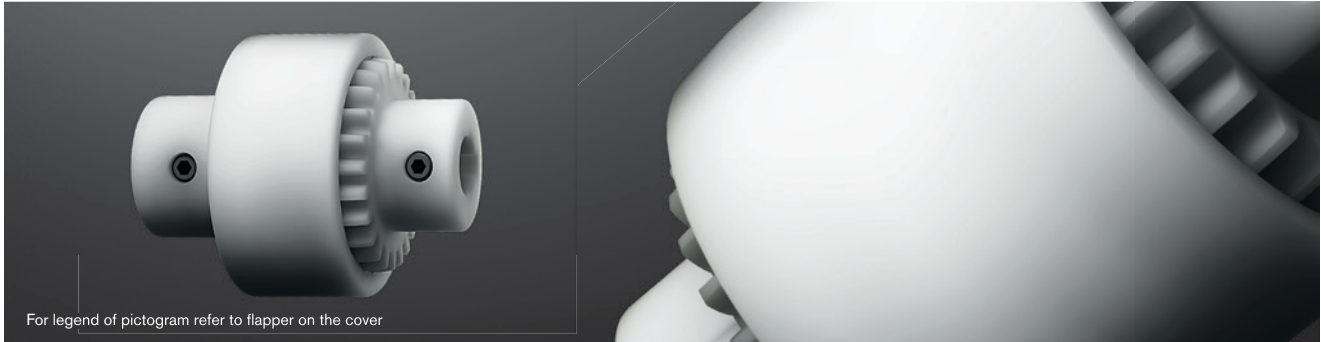

### Components

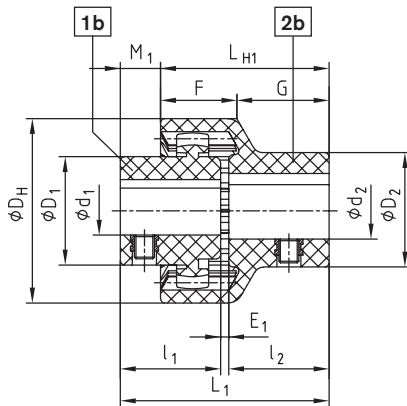

Type junior plug-in coupling (two-part)

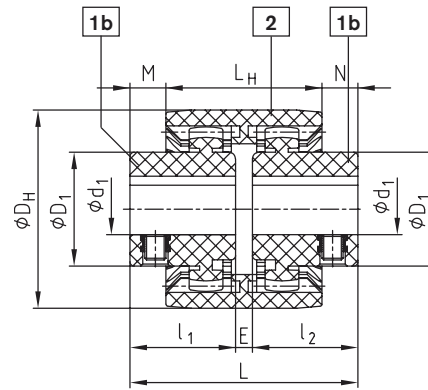

Type junior M coupling (three-part)

BoWex® junior plug-in coupling (two-part) and BoWex® junior M (three-part)																			
Size	Torque [Nm]		Finish bore				Dimensions [mm]										Max. speed [rpm]		
			Hub Component 1b <sup>1)</sup>		Plug-in sleeve Component 2b <sup>1)</sup>		DH	l <sub>1</sub> , l <sub>2</sub>	E <sub>1</sub>	L <sub>1</sub>	L <sub>H1</sub>	M 1	F	G	E	L		L <sub>H</sub>	M, N
	d <sub>1</sub> <sup>1)</sup>	D <sub>1</sub>	d <sub>2</sub> <sup>1)</sup>	D <sub>2</sub>															
14 M-14	5	10	Ø6, Ø7,	22	Ø6, Ø7, Ø8	22	40	23	2	48	40	8	18.5	21.5	4	50	37	6.5	6000
			Ø8, Ø9	25	Ø10, Ø11	25													
			Ø12, Ø14	26	Ø12, Ø14	26													
19 M-19	8	16	Ø10, Ø11, Ø12, Ø14	27	Ø12, Ø14,	27	47	25	2	52	42	10	19.0	23.0	4	54	37	8.5	6000
			Ø15, Ø16	30	Ø15, Ø16	29													
			Ø19	32	Ø19	35													
24 M-24	12	24	Ø10, Ø11,	26	Ø14, Ø16	32	53	26	2	54	45	9	21.5	23.5	4	56	41	7.5	6000
			Ø12	Ø19, Ø20		36													
			Ø14, Ø15,		Ø24	38													
			Ø16			36													

<sup>1)</sup> Finish bore with tolerance +0.05/-0.1; feather keyway ±0.08

Ordering example:	BoWex® junior 19	d <sub>1</sub> Ø19	d <sub>2</sub> Ø14
	Coupling size of two-part type or BoWex® junior M-19 three-part type	Finish bore	Finish bore

# BoWex® M, I Curved-tooth gear coupling®

Compact and maintenance-free



For legend of pictogram refer to flapper on the cover

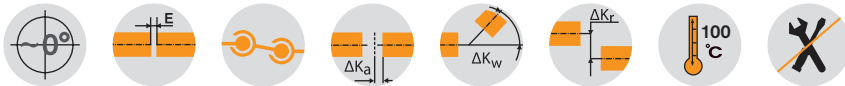

## Components

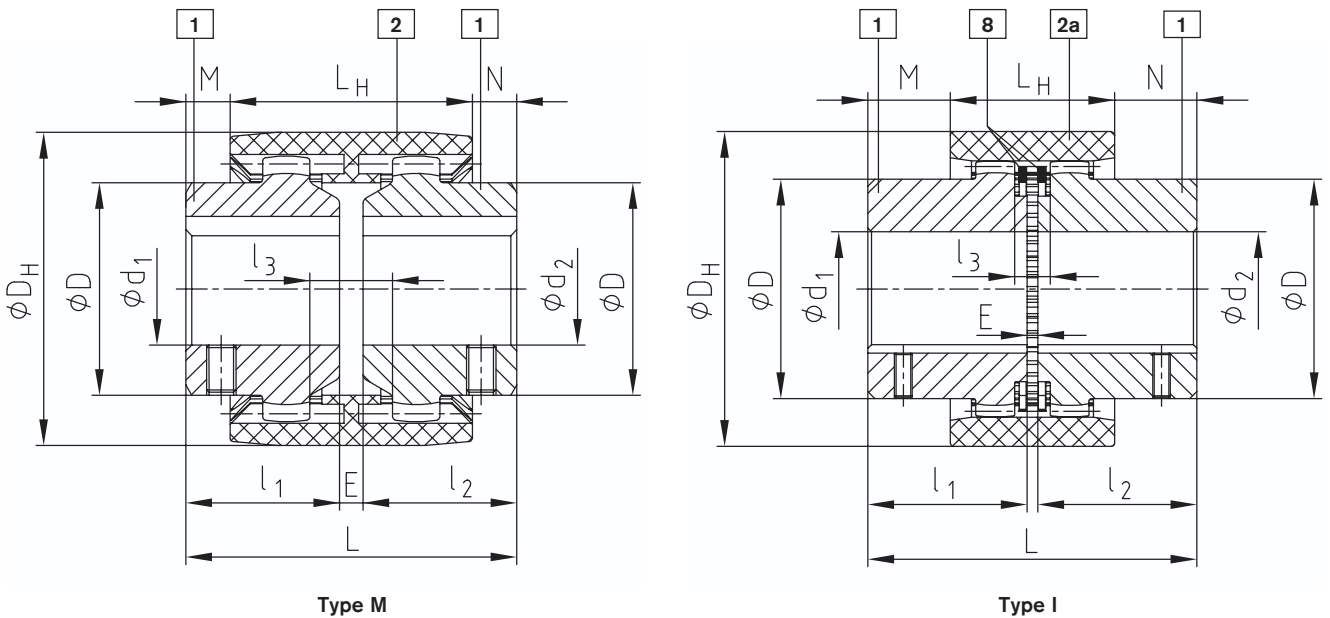

BoWex® type M, type I																						
Size	Torque [Nm]			Finish bore d1, d2		Dimensions [mm]											Weight with max. bore [kg]			Mass moment of inertia J with max. bore [kgcm <sup>2</sup> ]		
	T <sub>KN</sub>	T <sub>K max.</sub>	T <sub>KW</sub>	Pilot bored	max.	l <sub>1</sub> , l <sub>2</sub>	E	L	L <sub>H</sub>	M, N	l <sub>3</sub>	D	DH	Tip circle ØD <sub>Z</sub> hub	Number of teeth	Hub lengthened max. l <sub>1</sub> , l <sub>2</sub> <sup>1)</sup>	Sleeve	Hub	Total	Sleeve	Hub	Total
M-14	10	30	5	-	15	23	4	50	37	6.5	10	25	40	33	20	40	0.03	0.07	0.1	0.08	0.09	0.26
M-19	16	48	8	-	20	25	4	54	37	8.5	10	32	47	39	24	40	0.03	0.1	0.23	0.15	0.16	0.47
M-24	20	60	10	-	24	26	4	56	41	7.5	14	36	53	45	28	50	0.04	0.14	0.32	0.21	0.36	0.93
M-28	45	135	23	-	28	40	4	84	46	19	13	44	65	54	34	55	0.08	0.33	0.74	0.65	1.22	3.09
M-32	60	180	30	-	32	40	4	84	48	18	13	50	75	63	40	55	0.09	0.43	0.95	1.14	2.17	5.48
M-38	80	240	40	-	38	40	4	84	48	18	13	58	83	69	44	60	0.13	0.55	1.23	1.58	3.55	8.68
M-42	100	300	50	-	42	42	4	88	50	19	13	65	92	78	50	60	0.14	0.68	1.5	2.32	5.98	14.28
M-48	140	420	70	-	48	50	4	104	50	27	13	68	95	78	50	60	0.23	0.79	1.81	3.9	7.22	18.34
M-65	380	1140	190	21	65	55	4	114	68	23	16	96	132	110	42	70	0.55	1.9	4.35	21.2	31.8	84.8
I-80	700	2100	350	31	90	90	6	186	93	46.5	20	124	178	145	46	-	1.13	5.2	11.53	68.9	150.8	370.5
I-100	1200	3600	600	38	100	110	8	228	102	63	22	152	210	176	48	-	1.78	9.37	20.52	158.6	401.3	961.2
I-125	2500	7500	1250	45	125	140	10	290	134	78	30	192	270	225	54	-	3.88	19.44	42.76	562.9	1362.3	3287.5

<sup>1)</sup> Different lengths on request

Ordering example:	BoWex® M-28	d <sub>1</sub> Ø20	d <sub>2</sub> Ø28
	Size and type of coupling	Finish bore H7 keyway to DIN 6885 sheet 1 (JS9)	Finish bore H7 keyway to DIN 6885 sheet 1 (JS9)

# BoWex® M...C

## Curved-tooth gear coupling®

Compact and maintenance-free

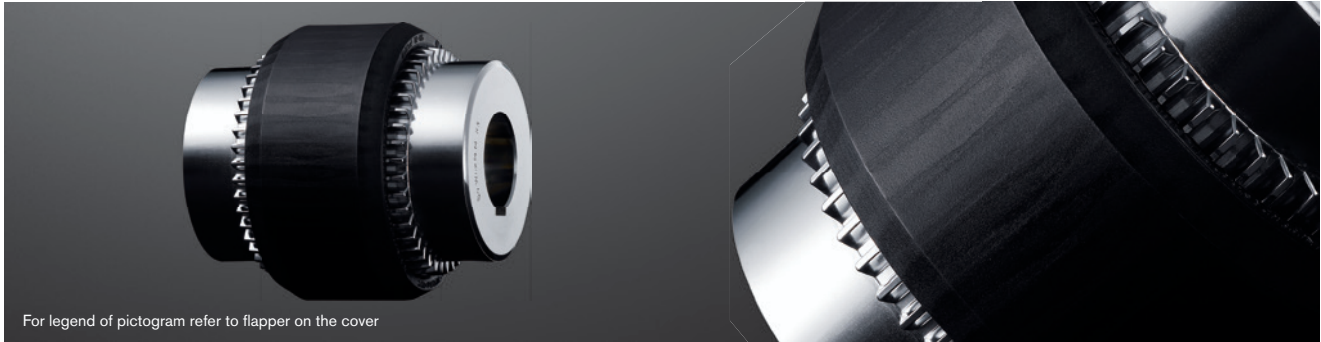

For legend of pictogram refer to flapper on the cover

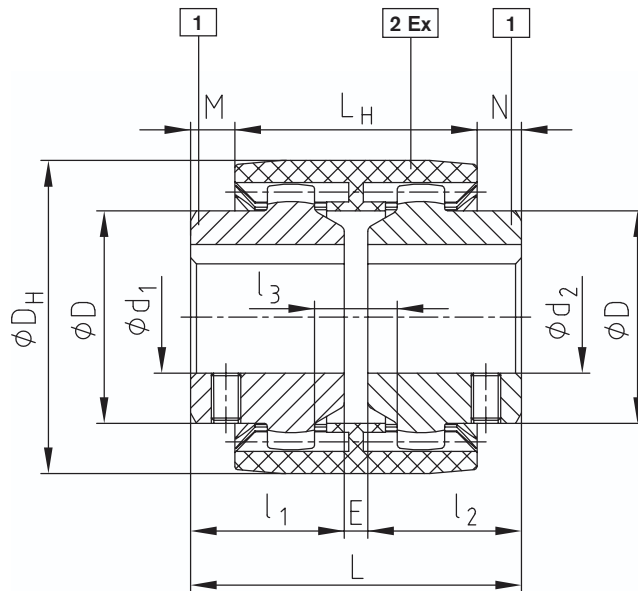
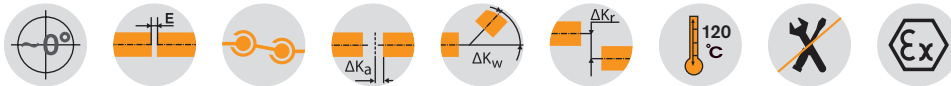

Type M...C

BoWex® Type M...C																								
Size	Torque [Nm]			Finish bore d1, d2		Dimensions [mm]													Weight with max. bore [kg]			Mass moment of inertia J with max. bore [kgcm <sup>2</sup> ]		
	TKN	TK max.	TKW	Pilot bored	max.	l <sub>1</sub> , l <sub>2</sub>	E	L	L <sub>H</sub>	M, N	l <sub>3</sub>	D	DH	Tip circle ØDZ hub	Number of teeth	Hub lengthened max. l <sub>1</sub> , l <sub>2</sub>	Sleeve	Hub	Total	Sleeve	Hub	Total		
M-14C	15	45	7,5	-	15	23	4	50	37	6,5	10	25	40	33	20	40	0,03	0,07	0,1	0,08	0,09	0,26		
M-19C	24	72	12	-	20	25	4	54	37	8,5	10	32	47	39	24	40	0,03	0,1	0,23	0,15	0,16	0,47		
M-24C	30	90	15	-	24	26	4	56	41	7,5	14	36	53	45	28	50	0,04	0,14	0,32	0,21	0,36	0,93		
M-28C	70	210	35	-	28	40	4	84	46	19	13	44	65	54	34	55	0,08	0,33	0,74	0,65	1,22	3,09		
M-32C	90	270	45	-	32	40	4	84	48	18	13	50	75	63	40	55	0,09	0,43	0,95	1,14	2,17	5,48		
M-38C	120	360	60	-	38	40	4	84	48	18	13	58	83	69	44	60	0,13	0,55	1,23	1,58	3,55	8,68		
M-48C	200	600	100	-	48	50	4	104	50	27	13	68	97	78	50	60	0,23	0,79	1,81	3,9	7,22	18,34		
M-65C	560	1680	280	21	65	55	4	114	68	23	16	96	134	110	42	70	0,55	1,9	4,35	21,2	31,8	84,8		
M-80C	1000	3000	500	31	90	90	6	186	75	46,5	20	124	172	145	46	-	1,13	5,2	11,53	68,9	150,8	370,5		

Ordering example:	BoWex® M-28C	d <sub>1</sub> Ø20	d <sub>2</sub> Ø28
	Size and type of coupling	Finish bore H7 keyway to DIN 6885 sheet 1 (JS9)	Finish bore H7 keyway to DIN 6885 sheet 1 (JS9)

# BoWex® AS and Spec.-I Curved-tooth gear coupling®

Compact and maintenance-free

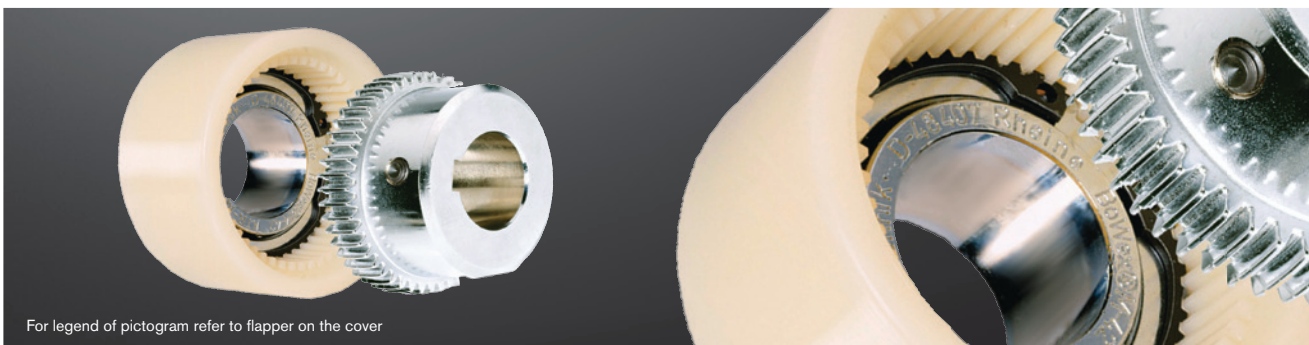

For legend of pictogram refer to flapper on the cover



## Components

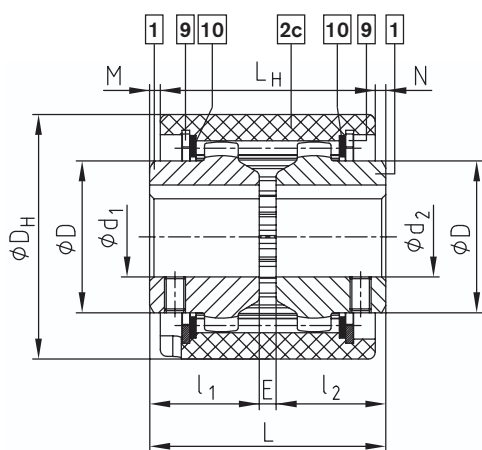

Type AS

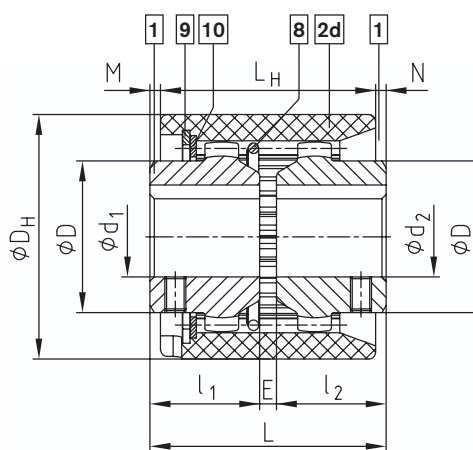

Type Spec.-I

BoWex® Type AS and type Spec.-I																		
Size	Pilot bore		Finish bore d <sub>1</sub> , d <sub>2</sub> max.	Dimensions [mm]								Weight with max. bore [kg]			Mass moment of inertia J with max. bore [kgcm <sup>2</sup> ]			
	Unbored	Pilot bored		l <sub>1</sub> , l <sub>2</sub>	E	L	L <sub>H</sub>	M, N	D	DH	Hub length. max. l <sub>1</sub> , l <sub>2</sub>	Sleeve	Hub	Total	Sleeve	Hub	Total	
24	x	-	For finish bores see stock programme	24	26	4	56	51	2.5	36	58	50	0.11	0.14	0.39	0.38	0.36	1.10
28	x	-		28	40	4	84	56	14	44	70	55	0.16	0.33	0.82	1.54	1.22	3.98
32	x	-		32	40	4	84	58	13	50	84	55	0.21	0.43	1.07	2.75	2.17	7.09
45	x	-		45	42	4	88	60	14	65	100	60	0.27	0.63	1.53	5.49	5.66	16.81
65	-	21		65	55	4	114	84	15	96	140	70	0.84	2.10	5.00	29.83	43.96	117.8
80	-	31		90	90	6	186	93	46.5	124	178	-	1.30	5.20	11.70	83.20	150.8	384.8
100	-	38		100	110	8	228	102	63	152	210	-	2.05	9.40	20.80	184.4	401.3	987.0
125	-	45	125	140	10	290	134	78	192	270	-	4.32	19.44	43.10	620.0	1362.3	3344.6	

For performance data see page 86.

Ordering example:	BoWex® 32 AS	d <sub>1</sub> Ø32	d <sub>2</sub> Ø32
	Size and type of coupling AS or Spec.-I	Finish bore H7 keyway to DIN 6885 sheet 1 (JS9)	Finish bore H7 keyway to DIN 6885 sheet 1 (JS9)

# BoWex® SG, SSR and Spec.-I/CD Curved-tooth gear coupling®

## Other coupling types



For legend of pictogram refer to flapper on the cover

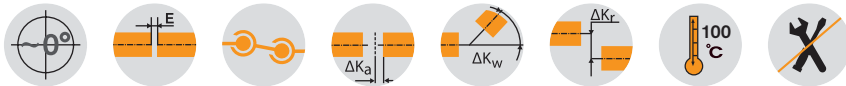

### Components

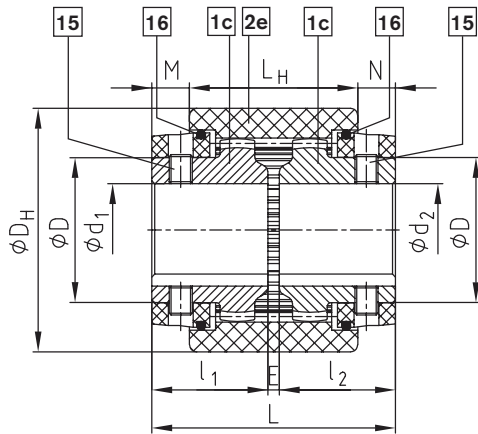

BoWex® Type SG with dust protection circlips

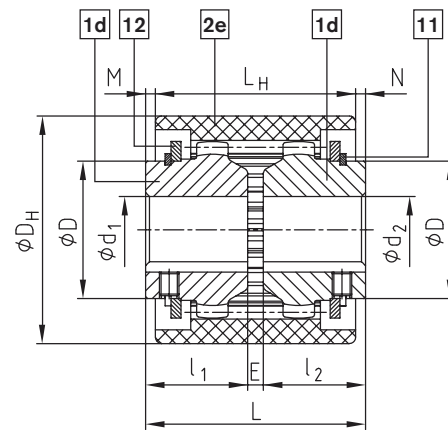

BoWex® Type SSR with Seeger circlips

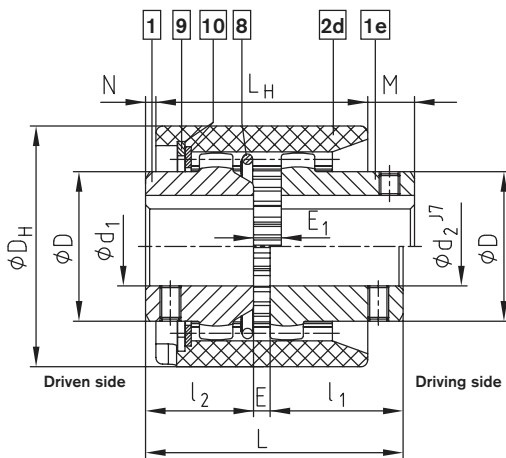

BoWex® Type Spec.-I/CD

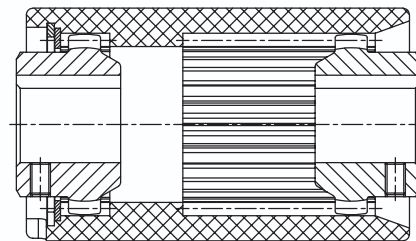

Type Spec.-I with a long PA-sleeve

# BoWex® SD/SD-D Curved-tooth gear coupling®

## Shiftable coupling (at standstill)

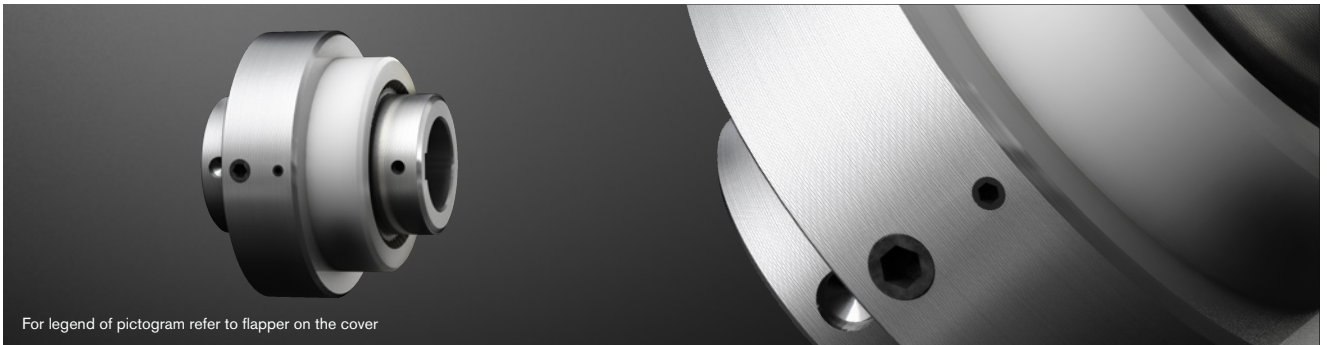

For legend of pictogram refer to flapper on the cover

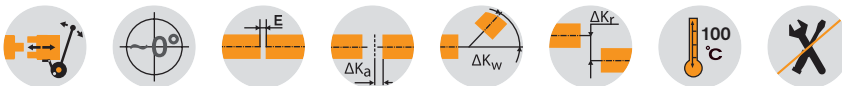

BoWex® Type SD																							
Size	Pilot bore		Finish bore d <sub>1</sub> , d <sub>2</sub>			Dimensions [mm]													Weight with max. bore [kg]		Mass moment of inertia J with max. bore [kgcm <sup>2</sup> ]		Shifting force [N]
	Un-bored	Pilot bored	d <sub>1</sub>	d <sub>1</sub> max.	d <sub>2</sub> max.	E	l <sub>1</sub>	l <sub>2</sub>	L	L <sub>H</sub>	l <sub>3</sub>	M	W	N	D	DH	D <sub>A</sub>	Shifting hub with sleeve	Driving hub	Shifting hub with sleeve	Driving hub		
24 SD	x	-	For finish bores see stock programme on page 88	24	24	4	26	50	80	52	31	10	19	18	36	58	78	1.08	0.14	8.23	0.36	140	
28 SD	x	-		28	28	4	40	55	99	57	33	21.5	21.5	20.5	44	70	88	1.50	0.33	15.62	1.22	180	
32 SD	x	-		32	32	4	40	55	99	58	33	20.5	21.5	20.5	50	84	100	1.85	0.43	22.87	2.17	180	
45 SD	x	-		45	45	4	42	60	106	63	37	21.5	22.5	21.5	65	100	125	2.56	0.68	46.07	5.66	250	
				48			50												29.5				0.79
65 SD	-	26		65	65	4	55	70	129	77	37	28	25	24	95	140	156	5.07	2.30	158.99	43.96	350	
80 SD	-	31		90	90	6	90	90	186	96	47	56	35	34	124	175	195	10.60	5.20	523.7	150.8	350	
100 SD	-	38		100	100	8	110	110	228	113	55	72	43	43	152	210	235	18.87	9.37	1350	401.3	400	
125 SD	-	45		125	125	10	140	140	290	149	70	89	52	52	192	270	298	40.40	9.44	4919	1362.3	450	

### Connection dimensions of BoWex® SD shifting ring (comp. 17) for mounting of: slip ring SD1 (s. catalogue on p. 89), shifting disk etc.

Size	Dimensions [mm]			
	L <sub>1</sub>	L <sub>2</sub>	z x G	s
24 SD	48	58	4 x M6	2
28 SD	48	58	4 x M6	2
32 SD	64	75	4 x M6	2
45 SD	75	90	4 x M8	2
65 SD	100	114	4 x M8	2
80 SD	130	145	4 x M8	3
100 SD	180	196	6 x M10	4
125 SD	220	236	6 x M10	4

Performance data/torques see type M (on page 99), max. circumferential speed v = 20 m/s, referring to ØD<sub>A</sub>  
Other sizes on request

Ordering example:	BoWex® 32 SD	d <sub>1</sub> Ø32	d <sub>2</sub> Ø32
	Size and type of coupling	Finish bore H7 keyway to DIN 6885 sheet 1 (JS9)	Finish bore H7 keyway to DIN 6885 sheet 1 (JS9)

Components

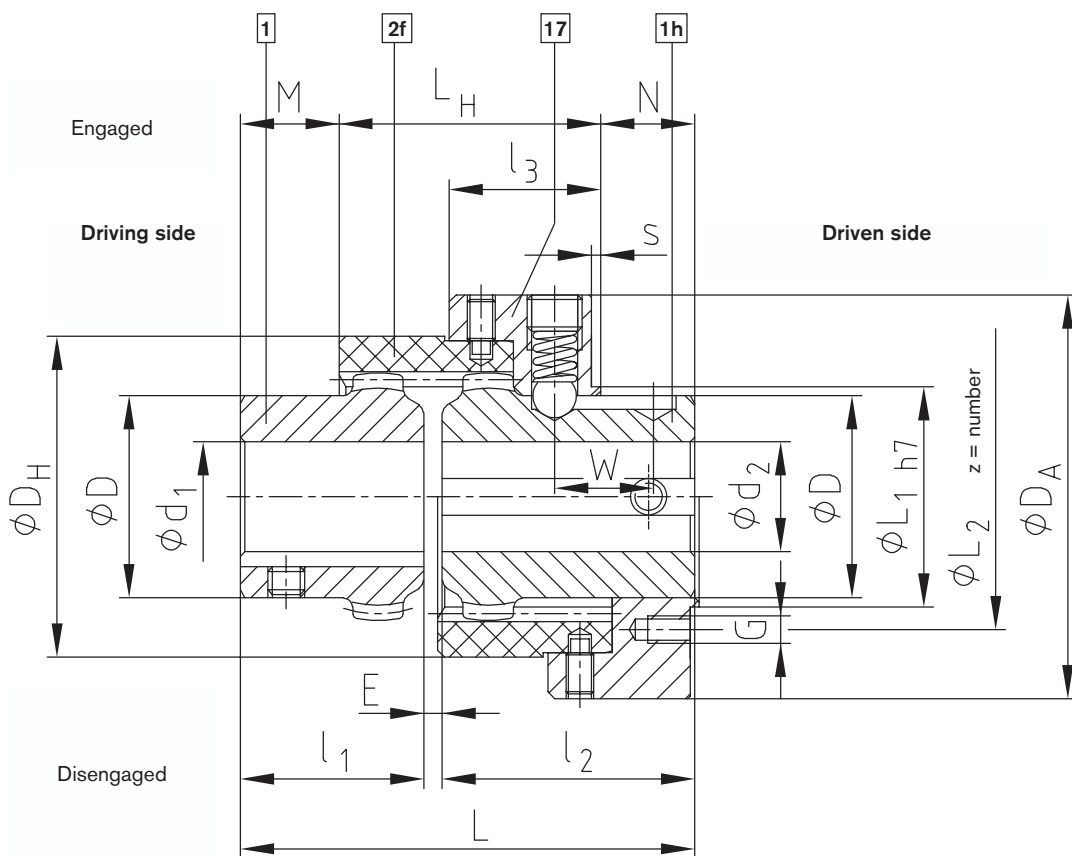

BoWex® SD

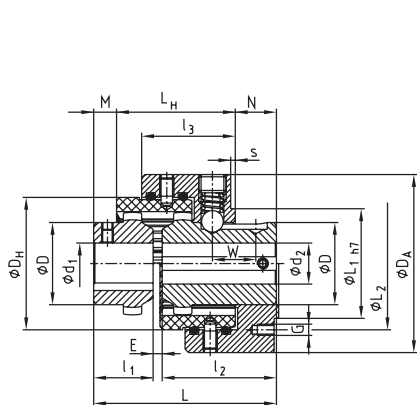

BoWex® SD-D

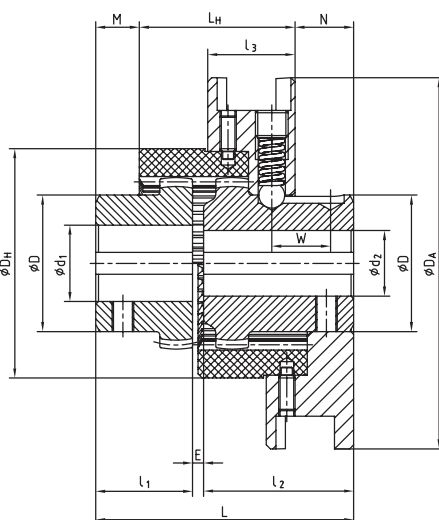

BoWex® SD2

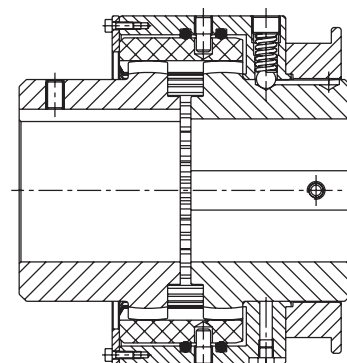

BoWex® SD-D3

GEARex®

# BoWex® SD1 Curved-tooth gear coupling®

## Shiftable coupling with shiftable linkage (at standstill)

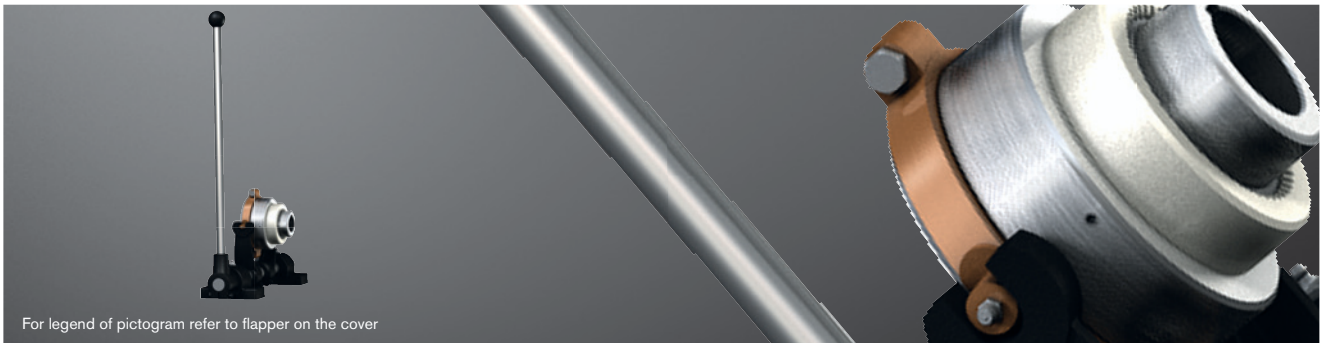

For legend of pictogram refer to flapper on the cover

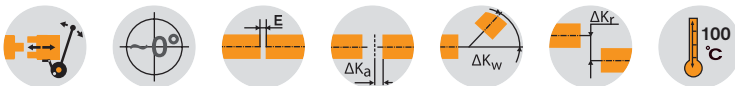

BoWex® Type SD1 and slip ring																					
Size	Finish bore			Dimensions [mm]																Shifting force [N]	
	d <sub>1</sub>	d <sub>1</sub> max.	d <sub>2</sub> max.	E	l <sub>1</sub>	l <sub>2</sub>	L	L <sub>G</sub>	l <sub>4</sub>	l <sub>5</sub>	M	W	t	D	DH	D <sub>A</sub>	D <sub>1</sub>	D <sub>2</sub> ±0.1 (keyway)	D <sub>5</sub>		n ±0.1 (keyway)
24 SD1		24	24	4	26	50	80	67	11	46	10	19	16	36	58	78	45	70.5	78	12.5	140
28 SD1		28	28	4	40	55	99	72	11	48	21.5	21.5	16	44	70	88	45	70.5	78	12.5	180
32 SD1		32	32	4	40	55	99	78	13.5	53	20.5	21.5	21	50	84	100	60	89.5	100	17.5	180
45 SD1		45	45	4	42	60	106	84	14	58	21.5	22.5	22	65	100	125	70	112.5	125	18	250
		48			114		29.5														
65 SD1		65	65	4	55	70	129	103	16	61	26	25	25	96	140	156	96	130.5	145	20.5	350
80 SD1		90	90	6	90	90	186	124	18.5	75	56	35	29	124	175	195	125	164.5	182	25.5	350
100 SD1		100	100	8	110	110	228	152	28	94	72	43	39	152	210	235	174	210.5	230	30.5	400
125 SD1		125	125	10	140	140	290	193	30.5	114	89	52	44	192	270	298	214	250.5	275	35.5	450

BoWex® Type SD1 - Shiftable linkage																					
Size	Shiftable linkage size	Slip ring size	Dimensions [mm]																Dimensions with m <sub>1</sub> max.		
			a	b	c	d	d <sub>3</sub>	d <sub>4</sub>	e	F	g <sub>1</sub>	L <sub>2</sub>	L <sub>3</sub>	m	m <sub>1</sub> min.	m <sub>1</sub> max.	A	B	m <sub>3</sub>	m <sub>4</sub>	m <sub>5</sub>
24 SD1	1	1.1																			
28 SD1	1	1.1	110	50	18	20	11	16	30	70	55	320	400	75	180	190	90	114		55	16
32 SD1	2	2.2				25				97.5	60	430	450		240	270	111	151	20	80	34
45 SD1	3	3.3	140			30		20	40	120		490	600	100	280	310	140	180		90	44
65 SD1	3	4.4		60	25					70		565	750				170	210			
80 SD1	4	5.5				35	13.5			50	147.5				321	365	200	244		100	54
100 SD1	5	6.6	160			40		30	50 <sup>1)</sup>	190	80	630	1085	120	365	410	250	300	30	110	62
125 SD1	5	7.7													-		300	350			

<sup>1)</sup> = With a continuous base plate dimension „e“ must be increased by at least 10 mm. The brackets of the driving and driven side have to be adjusted accordingly. Also available as type SD-D. Other sizes on request.

Performance data/torques see type M (on page 90), max. circumferential speed v = 20 m/s, referring to ØD<sub>A</sub> (see assembly instructions table 11)

Ordering example:	BoWex® 65 SD1	d <sub>1</sub> Ø32	d <sub>2</sub> Ø32	4.4	3
	Size and type of coupling	Finish bore H7 keyway to DIN 6885 sheet 1 (JS9)		Slip ring Size	Shiftable linkage Size

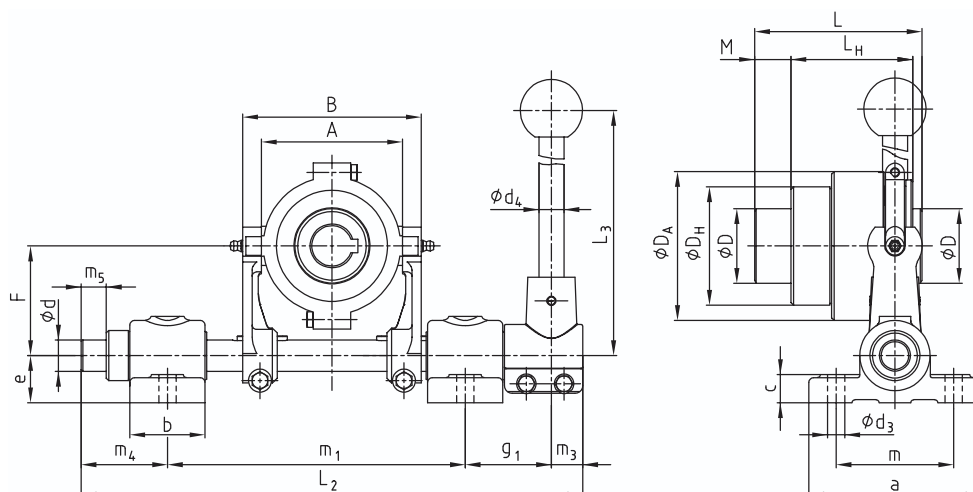
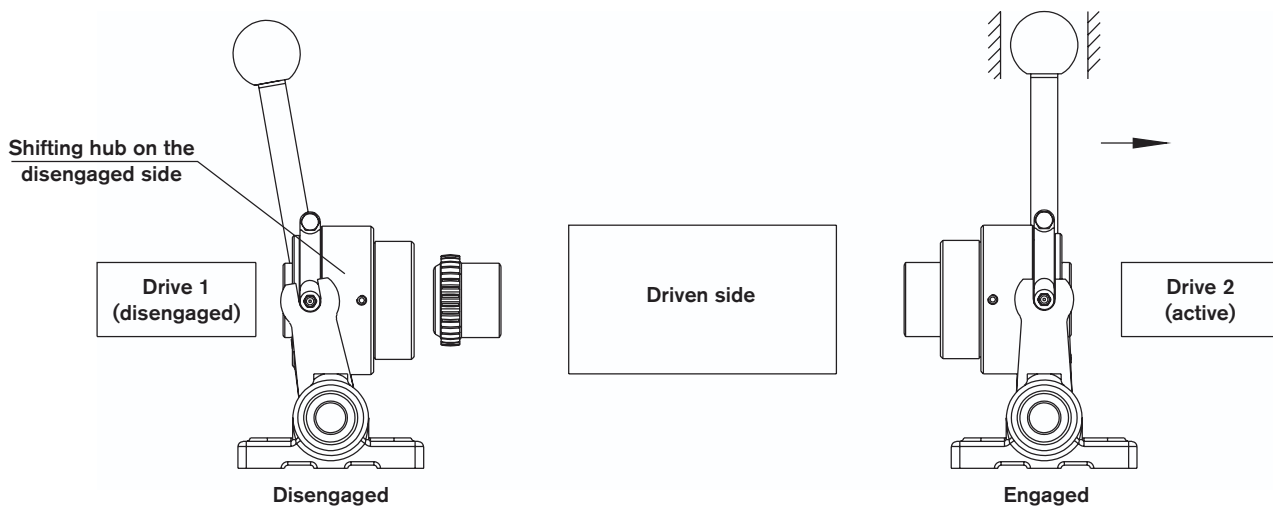
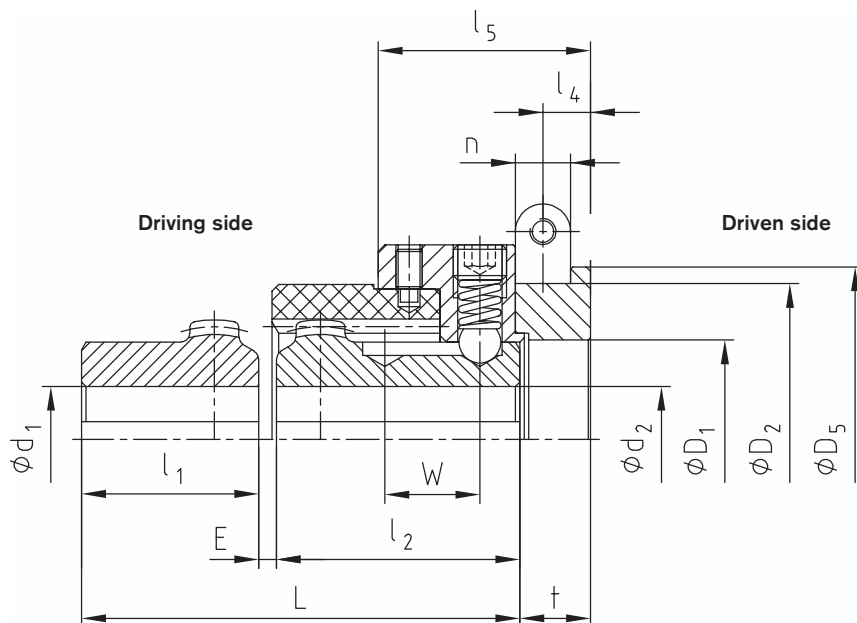

# BoWex® GT Curved-tooth gear coupling®

Split CFRP sleeve for high power density and radially dismountable

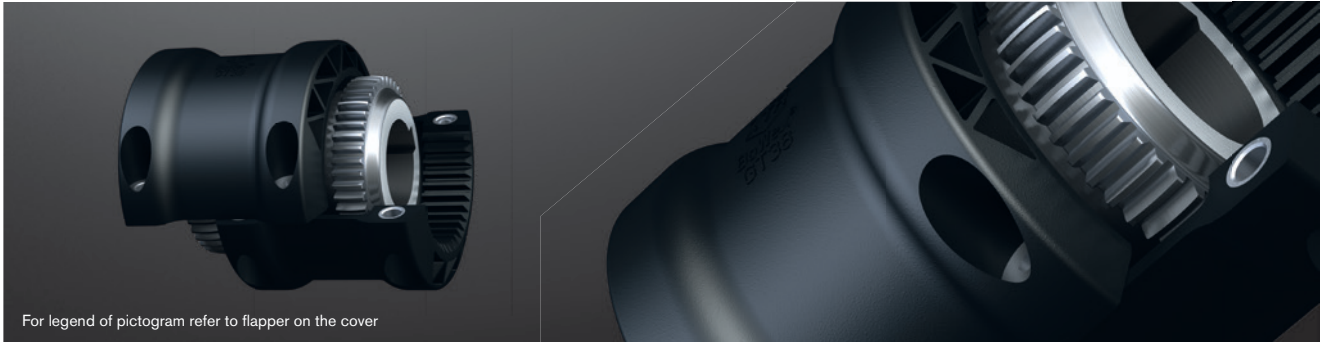

For legend of pictogram refer to flapper on the cover

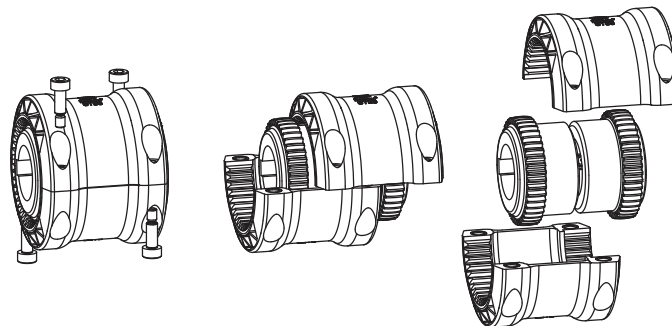
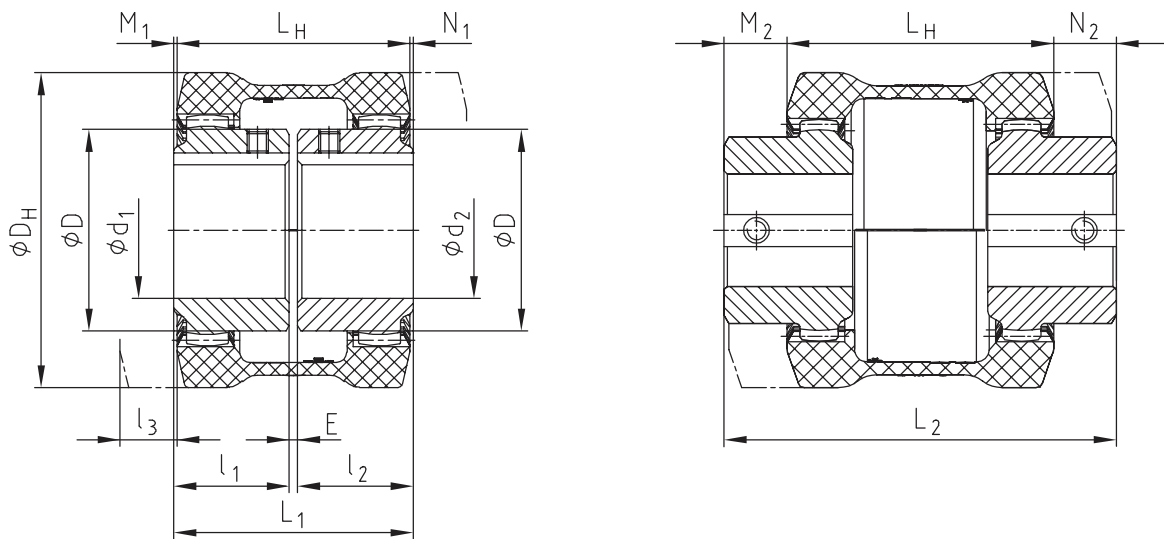

BoWex® Type GT with split sleeve

Size	Torque [Nm]			Finish bore d <sub>max.</sub>		Dimensions [mm]										Weight with max. bore [kg]			Mass moment of inertia J with max. bore [kgcm <sup>2</sup> ]			
	T <sub>KN</sub>	T <sub>K max.</sub>	T <sub>KW</sub>	d <sub>1</sub>	d <sub>2</sub>	D	DH	L <sub>H</sub>	I1	I2	I3	E	L <sub>1</sub>	L <sub>2</sub>	M <sub>1</sub> , N <sub>1</sub>	M <sub>2</sub> , N <sub>2</sub>	Sleeve	Hub	Total	Sleeve	Hub	Total
28	70	210	35	28	28	44	80	80	40	40	15	4	84	124	2	22	0.158	0.22	0.702	1.77	1.22	4.21
38	120	360	60	38	38	58	98	83	40	40	18	4	84	122	0.5	19.5	0.25	0.45	1.15	4.43	3.36	11.15
48	200	600	100	48	48	68	110	104	50	50	21	4	104	160	0	28	0.33	0.67	1.68	7.39	6.11	19.61
65	560	1680	280	65	65	96	150	111	55	55	27	4	114	160	1.5	24.5	0.69	1.54	3.77	28.9	31.80	92.5

l<sub>3</sub> = Drop-out center design dimension required

Ordering example:	BoWex® GT-28	d <sub>1</sub> Ø20	d <sub>2</sub> Ø28
	Size and type of coupling	Finish bore H7 keyway to DIN 6885 sheet 1 (JS9)	Finish bore H7 keyway to DIN 6885 sheet 1 (JS9)

# BoWex® M Curved-tooth gear coupling®

Made of corrosion-resistant materials



For legend of pictogram refer to flapper on the cover



## BoWex® junior plug-in coupling (two-part) and BoWex® junior M (three-part)

Size	Finish bore				Dimensions [mm]									
	Hub Component 1b		Plug-in sleeve Component 2b		DH	l <sub>1,2</sub>	E <sub>1</sub>	E	L <sub>H1</sub>	L <sub>H</sub>	L <sub>1</sub>	L	M 1	M, N
	d <sub>1</sub>	D <sub>1</sub>	d <sub>2</sub>	D <sub>2</sub>										
14	Ø6, Ø7, Ø8, Ø9	22	Ø8	22	40	23	2	4	40	37	48	50	8	6.5
M-14	Ø10, Ø11 Ø12, Ø14	25 26	Ø10, Ø11 Ø12, Ø14	25 26										
19	Ø12, Ø14	27	Ø14, Ø15	29	48	25	2	4	42	37	52	54	10	8.5
M-19	Ø16 Ø19	30 32	Ø19	35										
24	Ø10, Ø11, Ø12 Ø14, Ø15, Ø16	26 32	Ø14, Ø16	32	53	26	2	4	45	41	54	56	9	7.5
M-24	Ø18, Ø19, Ø20 Ø24	36 38	Ø19, Ø20 Ø24	36 40										

## BoWex® type M with stainless steel hubs

Size	Finish bore d <sub>1</sub> max., d <sub>2</sub> max.	Dimensions [mm]						
		DH	D	l <sub>1,2</sub>	E	L <sub>H</sub>	L	M, N
M-24	24	53	36	26	4	41	56	7.5
M-38	38	83	58	40	4	48	84	18
M-48	48	95	68	50	4	50	104	27

Other coupling sizes on request. Setscrews with BoWex® junior coupling are made of V4A as a standard. For performance data see page 88.

### Applications:

Food industry, print and paper industry, textile industry, sewage technology, wash-mobiles, chemical and pharmaceutical industry, offshore units, etc. For use in aggressive environment (air, water, chemicals, etc.).

### Type junior plug-in coupling (two-part)

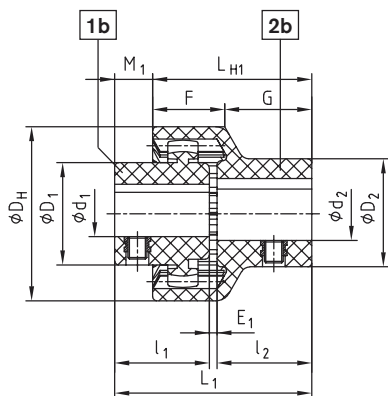

### Type junior M coupling (three-part)

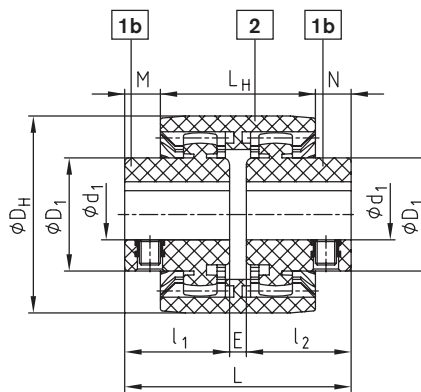

### Type M (V4A)

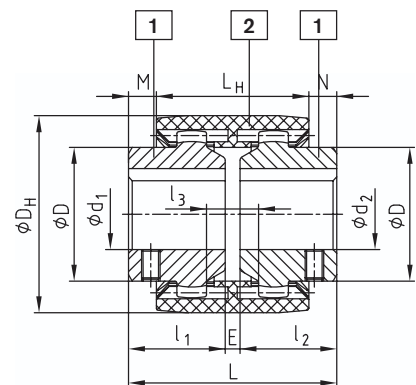

Ordering example:

BoWex® M-24 V4A	d <sub>1</sub> Ø20	d <sub>2</sub> Ø24
Size and type of coupling	Finish bore H7 keyway to DIN 6885 sheet 1 (JS9)	Finish bore H7 keyway to DIN 6885 sheet 1 (JS9)

# BoWex® Curved-tooth gear coupling®

## Taper bores

BoWex® with taper bore

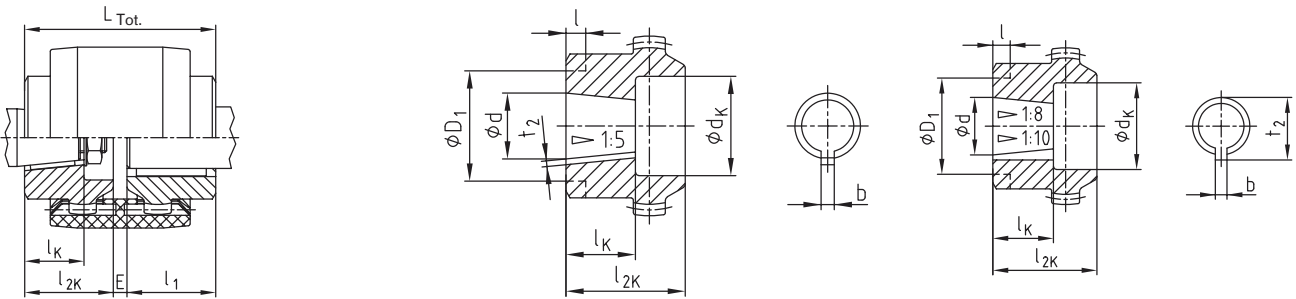

$$L_{Tot.} = l_1 + E + l_{2K}$$

see stock programme on page 88

Taper bores 1:5																						
Dimensions [mm]					Counterbore $d_K$ and hub length $l_{2K}$ [mm] Recess on hub collar $D_1 \times l$ [mm]																	
Code	Details of bores				14		19		24		28		32		38		42		48		65	
	$d^{+0.05}$	$b^{JS9}$	$t_2^{+0.1}$	$l_K$	$d_K$	$l_{2K}$	$d_K$	$l_{2K}$	$d_K$	$l_{2K}$	$d_K$	$l_{2K}$	$d_K$	$l_{2K}$	$d_K$	$l_{2K}$	$d_K$	$l_{2K}$	$d_K$	$l_{2K}$	$d_K$	$l_{2K}$
A-10	9.85	2	1.0	11.5	18	23	18	25	25	26	25	26	25	26	25	26						
B-17	16.85	3	1.8	18.5			30 x 7	30 x 7	30 x 7	30 x 5					30 x 5							
C-20	19.85	4	2.2	21.5					28	36	36	40	36	40	36	40	45	42	45	42	45	50
Cs-22	21.95	3	1.8	21.5					28	36	36	40	36	40	36	40	45	42	45	42		
D-25	24.85	5	2.9	26.5							36	40	36	40	36	40	45	42	45	42	45	50
E-30	29.85	6	2.6	31.5									36	40	45	55	45	55	45	55	45	55
F-35	34.85	6	2.6	36.5														52	60	55	60	
G-40	39.85	6	2.6	41.5														52	60	65	70	

Taper bores 1:8																						
Dimensions [mm]					Counterbore $d_K$ and hub length $l_{2K}$ [mm] Recess on hub collar $D_1 \times l$ [mm]																	
Code	Details of bores				14		19		24		28		32		38		42		48		65	
	$d^{+0.05}$	$b^{JS9}$	$t_2^{+0.1}$	$l_K$	$d_K$	$l_{2K}$	$d_K$	$l_{2K}$	$d_K$	$l_{2K}$	$d_K$	$l_{2K}$	$d_K$	$l_{2K}$	$d_K$	$l_{2K}$	$d_K$	$l_{2K}$	$d_K$	$l_{2K}$	$d_K$	$l_{2K}$
N/1	9.7 $\pm 0.015$	$2.4^{+0.05}$	10.85	17	18	26	18	25	25	26	25	30	25	30	25	30						
N/1c	11.6	$3^{JS9}$	12.90	16.5	18	23			25	26	25	30										
N/1e	13	$2.4^{+0.05}$	13.80	21					25	30	25	30			25	30						
N/1d	14	$3^{JS9}$	15.50	17.5	20	23	25	30	28	30	28	30	28	40								
N/2	17.287	$3.2^{+0.05}$	18.24	24					28	35	36	40	36	40	36	40	45	42	45	42	45	50
N/2a	17.287	$4^{JS9}$	18.94	24					28	35	36	40	36	40	36	40	45	42	45	42	45	50
N/2b	17.287	$3^{JS9}$	18.34	24					28	35					36	40	45	42	45	42		
N/3	22.002	$4^{JS9}$	23.40	28							36	40	36	40	36	40	45	42	45	42	45	50
N/4	25.463	$4.78^{+0.05}$	27.83	36							36	50	36	50	36	50	45	50	45	50	45	62
N/4b	25.463	$5^{JS9}$	28.23	36							36	50					45	50	45	50	45	62
N/4a	27	$4.78^{+0.05}$	28.80	32.5										36	50							
N/4g	28.45	$6^{JS9}$	29.32	38.5												36	60	45	60	45	60	
N/5	33.176	$6.38^{+0.05}$	35.39	44											45	60	45	60	45	60	45	62
N/5a	33.176	$7^{JS9}$	35.39	44													45	60	45	60	45	62

Taper bores 1:10																						
Dimensions [mm]					Counterbore $d_K$ and hub length $l_{2K}$ [mm]																	
Code	Details of bores				14		19		24		28		32		38		42		48		65	
	$d^{+0.05}$	$b^{JS9}$	$t_2^{+0.1}$	$l_K$	$d_K$	$l_{2K}$	$d_K$	$l_{2K}$	$d_K$	$l_{2K}$	$d_K$	$l_{2K}$	$d_K$	$l_{2K}$	$d_K$	$l_{2K}$	$d_K$	$l_{2K}$	$d_K$	$l_{2K}$	$d_K$	$l_{2K}$
CX-20	19.85	5	22.08	32							36	50			36	50	45	50	45	50		
DX-25	24.95	6	26.68	45									36	50			45	60	45	60	45	60
EX-30	29.75	8	31.88	50													45	60	45	60	45	70

# BoWex® Curved-tooth gear coupling®

## Spline hubs and inch bores

BoWex® spline hubs – basic programme

Spline hub (N)

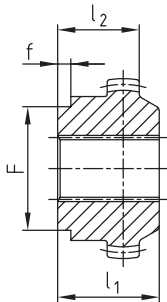

Clamping hub (K)

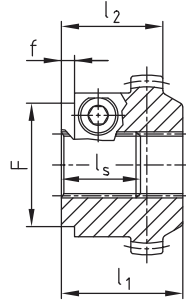

If it is not possible to fasten the hubs of pump shafts with involute spline by means of an end plate and a screw, we recommend to use our spline clamping hub.

Radial clamping ensures a backlash-free tight fit on the pump shaft.

Spline and clamping hubs acc. to DIN 5480

Size	Dimensions [mm]							Order designation specify coupling size
	Type	Spline size	l1	l2	ls	F	f	
42	N	25x1.25x18	42	-	-	-	-	P000205
	K	25x1.25x18	42	-	-	-	-	P500202
48	K	30x2x14	42	-	-	60	6	P500203
	N	30x2x14	50	-	-	60	6	P000206
	K	30x2x14	50	-	-	60	6	P500203
	N	35x2x16	55	-	-	60	6	P000303
65	K	35x2x16	60	-	-	60	6	P500301
	N	40x2x18	55	-	-	78	6	P000304
	K	40x2x18	60	-	-	78	6	P500302
	K	45x2x21	55	-	-	78	6	P500401

Spline and clamping hubs to ANSI B92.1

Size	Dimensions [mm]							Order designation specify coupling size
	Type	Spline size	l1	l2	ls	F	f	
42	K	PH-S 5/8"	42	-	-	-	-	P558101
		16/32DP, z=9						
42	K	PI-S 3/4"	-	35	-	-	-	P559101
		16/32DP, z=11						
42	K	PB-S 7/8"	42	-	-	60	3	P567101
		16/32DP, z=13						
42	K	PB-BS 1"	42	-	27	50	6	P660201
		16/32DP, z=15						
48	K	PA-S 3/8"	50	-	45	52	7	P663301
		16/32DP, z=21						
65	K	PA-S 3/8"	55	-	48	52	5	P663301
		16/32DP, z=21						
65	K	PC-S 1 1/4"	55	-	44	52	5	P656201
		12/24DP, z=14						

Inch bores – see stock programme on page 88

Bore and keyway acc. to ANSI/AGMA 9002-C14 Bore (clearance fit) Keyway (commercial class fit)						Bore and keyway acc. to ANSI/AGMA 9002-C14 Bore (clearance fit) Keyway (commercial class fit)					
KTR Code	Bore Ø [Inch]	Width of keyway [Inch]	Bore Ø [mm]	Width of keyway [mm]	Keyway depth/Tolerance +0.381 [mm]	KTR Code	Bore Ø [Inch]	Width of keyway [Inch]	Bore Ø [mm]	Width of keyway [mm]	Keyway depth/Tolerance +0.381 [mm]
Tb	3/8	1/8	9.525 +0.0254	3.175 +0.05	10.972	Sd	1 1/8	5/16	28.575 +0.0254	7.937 +0.051	32.105
DNB	7/16	3/32	11.112 +0.0254	2.382 +0.051	12.293	Js	1 1/4	1/4	31.75 +0.0254	6.35 +0.051	34.721
T	1/2	3/16	12.7 +0.0254	4.762 +0.051	14.757	K	1 1/4	5/16	31.75 +0.0254	7.937 +0.051	35.331
Ta	1/2	1/8	12.7 +0.0254	3.175 +0.051	14.224	Ma	1 3/8	5/16	34.925 +0.0254	7.937 +0.051	38.557
DNC	17/32	1/8	13.495 +0.0254	3.175 +0.051	15.011	RH1	1 3/8	3/8	34.925 +0.0254	9.525 +0.063	39.141
Do	9/16	1/8	14.287 +0.0254	3.175 +0.051	15.824	Cb	1 7/16	3/8	36.512 +0.0254	9.525 +0.063	40.767
E	5/8	1/8	15.875 +0.0254	3.175 +0.051	17.424	Ca	1 1/2	5/16	38.1 +0.0254	7.937 +0.051	41.783
Es	5/8	5/32	15.875 +0.0254	3.968 +0.051	17.729	C	1 1/2	3/8	38.1 +0.0254	9.525 +0.0635	42.392
Ed	5/8	3/16	15.875 +0.0254	4.762 +0.051	18.008	Nb	1 5/8	3/8	41.275 +0.0254	9.525 +0.0635	45.618
DNH	11/16	3/16	17.462 +0.0254	4.762 +0.051	19.634	Ls	1 3/4	3/8	44.45 +0.0254	9.525 +0.0635	48.818
Ad	3/4	1/8	19.05 +0.0254	3.175 +0.051	20.624	L	1 3/4	7/16	44.45 +0.0254	11.112 +0.0635	49.428
A	3/4	3/16	19.05 +0.0254	4.762 +0.051	21.259	Lu	1 7/8	1/2	47.625 +0.0254	12.7 +0.0635	53.238
G	7/8	3/16	22.225 +0.0254	4.762 +0.051	24.485	Da	1 15/16	1/2	49.212 +0.0254	12.7 +0.0635	54.864
F	7/8	1/4	22.225 +0.0254	6.35 +0.051	25.069	Ds	2	1/2	50.8 +0.0254	12.7 +0.0635	56.464
Gf	15/16	1/4	23.812 +0.0254	6.35 +0.051	26.695	Pa	2 1/8	1/2	53.975 +0.0381	12.7 +0.063	59.69
H	1	3/16	25.4 +0.0254	4.762 +0.051	27.686	U	2 1/4	1/2	57.15 +0.0381	12.7 +0.063	62.915
Hs	1	1/4	25.4 +0.0254	6.35 +0.051	28.295	Ub	2 3/8	5/8	60.325 +0.0381	15.875 +0.076	67.335
R	1 1/16	3/16	26.987 +0.0254	4.762 +0.051	29.286	Wd	3 3/8	7/8	85.725 +0.0381	22.225 +0.076	95.504
Sb	1 1/8	1/4	28.575 +0.0254	6.35 +0.051	31.521	Wf	3 5/8	7/8	92.075 +0.0381	22.225 +0.076	101.955

The splines and inch bores specified are only a part of KTR's options. Many other variants are available, too.

# GEARex® FA, FB and FAB

## All-steel gear couplings

Coupling in accordance with AGMA 9008-B00, high power density



For legend of pictogram refer to flapper on the cover



### Dimensions

Size	Pilot bore	Dimensions [mm]															
		Max. finish bore		Dimensions [mm]													
		d <sub>1</sub> , d <sub>2</sub>	l <sub>1</sub> , l <sub>2</sub>	Hub lengthened max. l <sub>1</sub> , l <sub>2</sub> <sup>2)</sup>	E <sub>FA</sub>	E <sub>FB</sub>	E <sub>FAB</sub>	L <sub>FA</sub>	L <sub>FB</sub>	L <sub>FAB</sub>	L <sub>3</sub>	D	DA <sub>1</sub>	DA <sub>2</sub>	F <sup>1)</sup>	d <sub>3</sub> <sup>1)</sup>	
10	26	50	43	105	3	21	12	89	107	98	55	67	111	83	74	52	
15	26	65	50	115	3	15	9	103	115	109	59	87	142	106	84	68	
20	31	82	62	130	3	31	17	127	155	141	79	108	174	129	107	85	
25	38	100	76	150	5	29	17	157	181	169	93	130	213	157	126	105	
30	44.5	115	90	170	5	33	19	185	213	199	109	153	240	181	148	125	
35	46	135	105	185	6	40	23	216	250	233	128	180	280	213	172	150	
40	52	160	120	215	6	42	24	246	282	264	144	214	318	249	192	175	
45	80	175	135	245	8	50	29	278	320	299	164	233	347	273	216	190	
50	80	195	150	295	8	56	32	308	356	332	182	260	390	308	241	220	
55	90	215	175	300	8	70	39	358	420	389	214	283	425.5	333	279	250	
60	100	240	190	305	8	84	46	388	464	426	236	312	457	364.5	316	265	
70	100	285	220	310	10	76	43	450	516	483	263	371	527	424	360	300	

### Technical data

Size	Torque [Nm] <sup>3)</sup>		Max. speed [rpm]	Weight with max. bore [kg]			Mass moment of inertia with max. bore [kgm <sup>2</sup> ]	Dowel screw (10.9)		
	T <sub>KN</sub>	T <sub>KN</sub> (42CrMo4)		Sleeve	Hub	Total		z	M	T <sub>A</sub> [Nm]
10	930	1580	8500	0.75	0.55	2.75	0.004	6	M6	15
15	2000	3300	6400	1.50	1.10	5.60	0.015	8	M8	36
20	3500	6300	5400	2.40	2.10	9.50	0.037	6	M10	72
25	6500	11000	4500	4.30	3.60	16.60	0.096	6	M12	125
30	10000	17400	4000	5.70	6.20	25.00	0.178	8	M12	125
35	17000	28800	3500	9.50	9.90	40.90	0.410	8	M14	200
40	28500	48500	3100	11.60	16.00	57.50	0.746	8	M14	200
45	37000	62000	3000	15.40	21.40	76.40	1.163	10	M14	200
50	51000	86000	2500	25.30	29.50	113.50	2.229	8	M18	430
55	65000	110000	2300	31.00	40.20	149.00	3.415	14	M18	430
60	85000	145000	2100	32.10	52.80	175.70	4.514	14	M18	430
70	135000	240000	1850	42.50	85.50	265.50	9.212	16	M20	610

■ = Standard

<sup>1)</sup> Space required to align the coupling and replace the gasket

<sup>2)</sup> Lengthened hubs available as a standard for type FA only. For type FB and FAB lengthened hubs are available on request only.

<sup>3)</sup> Maximum torque of the coupling T<sub>K max</sub> = rated torque of the coupling T<sub>KN</sub> x 2. For selection see page 14 et seqq.

Ordering  
example:

GEARex® FA 10	d <sub>1</sub> Ø50	d <sub>2</sub> Ø50
Type and size of coupling	Finish bore with keyway to DIN 6885 sheet 1	Finish bore with keyway to DIN 6885 sheet 1

Type FA

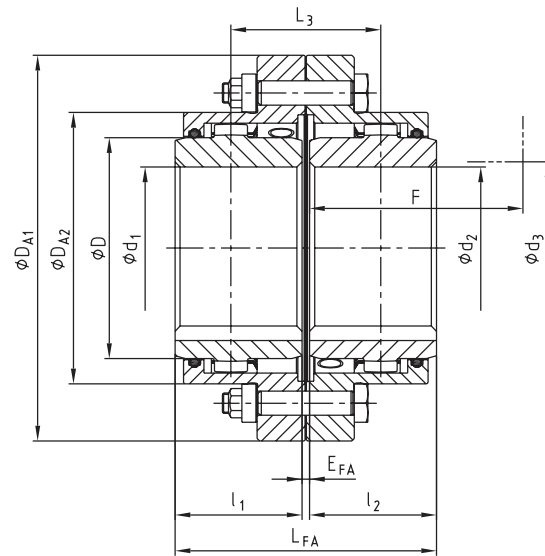

Type FB

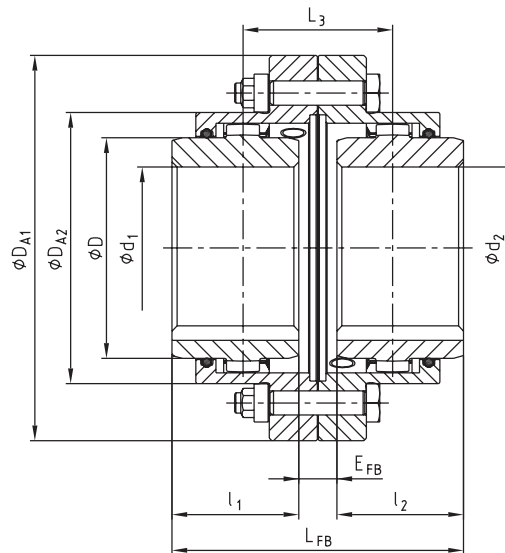

Type FAB

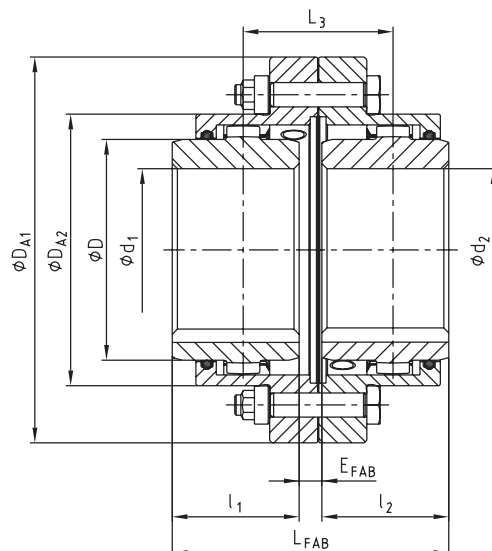

# GEARex® DA, DB and DAB All-steel gear couplings

Easy to assemble, high power density

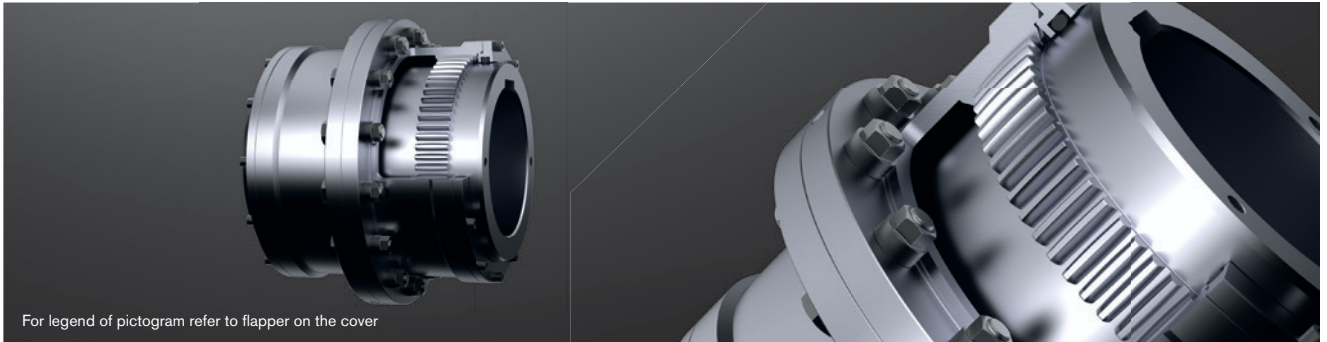

For legend of pictogram refer to flapper on the cover

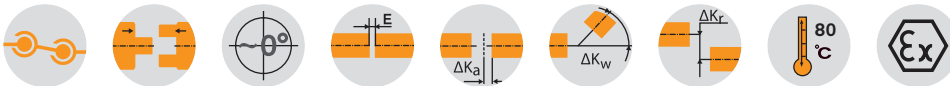

## Dimensions

Size	Pilot bore	Max. finish bore d <sub>1</sub> , d <sub>2</sub>	Dimensions [mm]													
			l <sub>1</sub> , l <sub>2</sub>	Hub lengthened max. l <sub>1</sub> , l <sub>2</sub> <sup>2)</sup>	EDA	EDB	EDAB	LDA	LDB	LDAB	L <sub>3</sub>	D	DA <sub>1</sub>	DA <sub>2</sub>	F <sup>1)</sup>	d <sub>3</sub> <sup>1)</sup>
20	31	82	62	130	3	31	17	127	155	141	79	108	187	146	107	85
25	38	100	76	150	5	29	17	157	181	169	93	130	220	172	126	105
30	44.5	115	90	170	5	33	19	185	213	199	109	153	248	194	140	125
35	46	135	105	185	6	40	23	216	250	233	128	180	285	228	155	155
40	52	160	120	215	6	42	24	246	282	264	144	214	335	270	180	180
45	80	175	135	245	8	50	29	278	320	299	164	233	358	294	195	200
50	80	195	150	295	8	56	32	308	356	332	182	260	390	322	210	230
55	90	215	175	300	8	70	39	358	420	389	214	283	425.5	354	235	250
60	100	240	190	305	8	84	46	388	464	426	236	312	457	380	270	275
70	100	285	220	310	10	76	43	450	516	483	263	371	527	445	300	335
80	140	300	280	-	10	50	30	570	610	590	310	394	545	475	360	358
85	160	325	292	-	13	53	33	597	637	617	325	430	585	515	372	395
90	180	350	305	-	13	83	48	623	693	658	353	464	640	560	385	428
100	220	390	330	-	13	93	53	673	753	713	383	512	690	612	410	465
110	220	420	350	-	20	296	158	720	996	858	508	560	765	665	440	515
120	260	450	420	-	25	421	223	865	1261	1063	643	608	825	720	510	560
130	300	500	440	-	25	415	220	905	1295	1100	660	684	980	805	540	628
140	380	550	460	-	20	430	225	940	1350	1145	685	750	1055	875	560	695
150	460	630	520	-	30	460	245	1070	1500	1285	765	850	1180	975	630	785

## Technical data

Size	Torque [Nm] <sup>3)</sup>		Max. speed [rpm]	Weight with max. bore [kg]			Mass moment of inertia with max. bore [kgm <sup>2</sup> ]	Dowel screw (10.9)		
	T <sub>KN</sub>	T <sub>KN</sub> (42CrMo4)		Sleeve	Hub	Total		z	M	T <sub>A</sub> [Nm]
20	3500	6300	5400	3.6	2.1	12.8	0.056	6	M10	72
25	6500	11000	4500	5.5	3.6	20.3	0.125	6	M12	125
30	10000	17400	4000	6.9	6.2	28.9	0.219	8	M12	125
35	17000	28800	3500	11.2	9.8	46.6	0.488	8	M14	200
40	28500	48500	3100	16.3	15.9	70.9	1.011	8	M14	200
45	37000	62000	3000	20.2	21.4	90.7	1.482	10	M14	200
50	51000	86000	2500	27.0	29.5	123.5	2.474	8	M18	430
55	65000	110000	2300	32.6	40.2	159.1	3.714	14	M18	430
60	85000	145000	2100	32.0	52.8	184.4	4.810	14	M18	430
70	135000	240000	1850	43.8	85.5	280	9.907	16	M20	610
80	175000	300000	1750	64	117	362	14.214	18	M20	610
85	225000	380000	1650	75	148	446	20.320	20	M20	610
90	-	500000	1550	101	183	568	31.036	20	M24	1000
100	-	650000	1500	117	232	698	45.358	24	M24	1000
110	-	820000	1250	140	295	940	73.880	20	M30	1700
120	-	1050000	1150	188	430	1312	118.40	24	M30	1700
130	-	1450000	1000	330	595	1965	235.431	20	M36	2800
140	-	1950000	950	391	751	2411	343.432	24	M36	2800
150	-	2750000	850	488	1057	3242	575.453	30	M36	2800

■ = Standard

<sup>1)</sup> Space required to align the coupling and replace the gasket

<sup>2)</sup> Lengthened hubs as a standard available for type DA only. For type DB and DAB lengthened hubs available on request only.

<sup>3)</sup> Maximum torque of the coupling T<sub>K max</sub> = rated torque of the coupling T<sub>KN</sub> x 2. For selection see page 14 et seqq.

Ordering  
example:

GEARex® DA 80	d <sub>1</sub> Ø300	d <sub>2</sub> Ø300
Type and size of coupling	Finish bore with keyway to DIN 6885 sheet 1	Finish bore with keyway to DIN 6885 sheet 1

Type DA

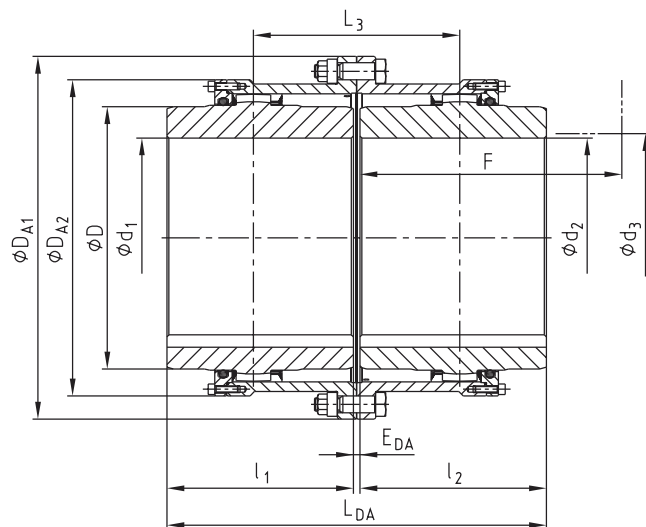

Type DB

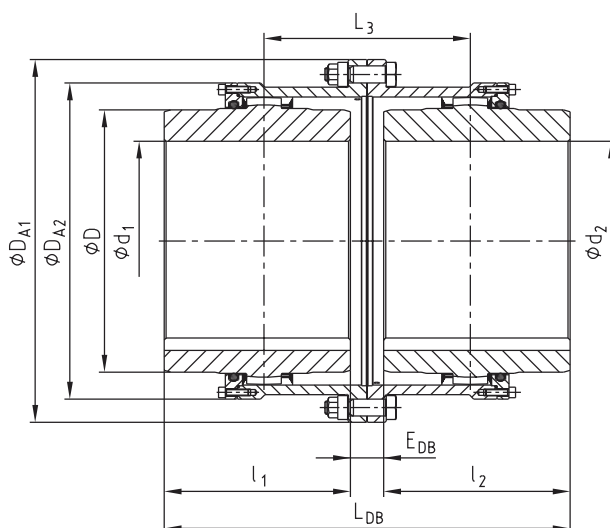

Type DAB

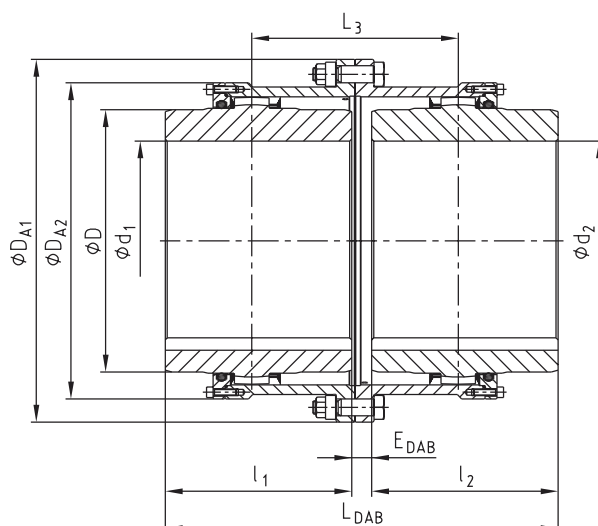

# GEARex® FBR and DBR All-steel gear coupling

## All-steel gear coupling with brake disk

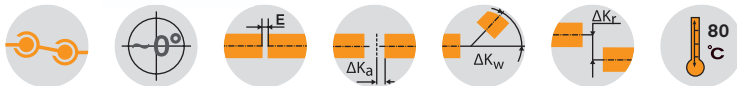
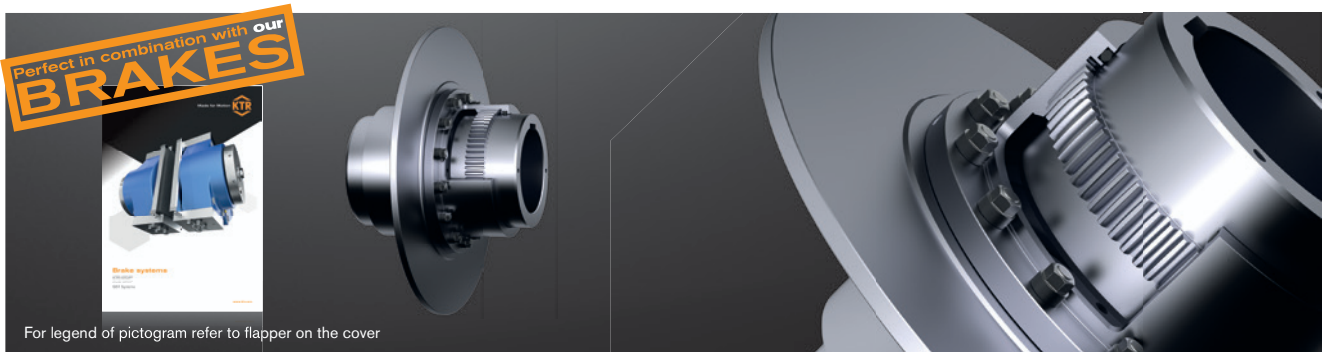

Dimensions																	
Size	Pilot bore	Max. finish bore		Dimensions [mm]													
		d <sub>1</sub> , d <sub>2</sub>	l <sub>1</sub> , l <sub>2</sub>	Hub lengthened max. l <sub>1</sub> , l <sub>2</sub> <sup>3)</sup>	E <sub>A</sub>	E <sub>B</sub>	L <sub>A</sub>	L <sub>B</sub>	L <sub>3</sub>	N	D	DA1 <sup>4)</sup>	DA2 <sup>4)</sup>	F <sup>2)</sup>	d <sub>3</sub> <sup>2)</sup>	a	
10 <sup>1)</sup>	26	50	43	105	16	34	102	120	68	N = L <sub>A</sub> • 0.5 or L <sub>B</sub> • 0.3	67	111	83	74	52	1.8	
15 <sup>1)</sup>	26	65	50	115	23	35	123	135	79		87	142	106	84	68	2.3	
20	31	82	62	130	20	48	144	172	96		108	174	129	107	85	2.3	
25	38	100	76	150	26	50	178	202	114		130	213	157	126	105	2.3	
30	44.5	115	90	170	25	53	205	233	129		153	240	181	148	125	2.3	
35	46	135	105	185	33	67	243	277	155		180	280	213	172	150	3.3	
40	52	160	120	215	21	57	261	297	159		214	318	249	192	175	3.3	
45	80	175	135	245	26	68	296	338	182		233	347	273	216	190	3.3	
50	80	195	150	295	27	75	327	375	201		260	390	308	241	220	3.3	

Technical data										
Size	Torque [Nm] <sup>5)</sup>		Dowel screw (10.9)			Weight with max. bore excluding brake disk [kg]		Max. speed <sup>6)</sup>		
	T <sub>KN</sub>	T <sub>KN</sub> (42CrMo4)	z	M	TA [Nm]	FBR	DBR	ØA x b [mm]	n [rpm]	
10 <sup>1)</sup>	930	1580	6	M6	15	2.75	-	250 x 12.7	3900	
15 <sup>1)</sup>	2000	3300	8	M8	36	5.60	-	300 x 12.7	3300	
20	3500	6300	6	M10	72	9.50	12.8	315 x 12.7	3100	
25	6500	11000	6	M12	125	16.60	20.3	400 x 12.7	2400	
30	10000	17400	8	M12	125	25.00	28.9	400 x 12.7	2400	
35	17000	28800	8	M14	200	40.90	46.6	460 x 12.7	2100	
40	28500	48500	8	M14	200	57.50	70.9	515 x 12.7	1900	
45	37000	62000	10	M14	200	76.40	90.7	610 x 12.7	1600	
50	51000	86000	8	M18	430	113.50	123.5	710 x 12.7	1400	

Recommended selection of coupling/brake disk										
Size	Brake disk ØA x b <sup>7)</sup>									
	250 x 12.7	300 x 12.7	315 x 12.7	350 x 12.7	400 x 12.7	460 x 12.7	515 x 12.7	610 x 12.7	710 x 12.7	810 x 12.7
10 <sup>1)</sup>	x	x	x							
15 <sup>1)</sup>		x	x	x						
20			x	x	x	x				
25					x	x	x	x		
30					x	x	x	x	x	
35						x	x	x	x	
40							x	x	x	x
45								x	x	x
50									x	x

■ = Standard

<sup>1)</sup> Size 10 and 15 available as type F only.

<sup>2)</sup> Space required to align the coupling and replace the gasket

<sup>3)</sup> Lengthened hubs available as a standard in connection with hub configuration A only.

<sup>4)</sup> Dimensions of type F For dimensions of type D see page 110.

<sup>5)</sup> Maximum torque of the coupling T<sub>K max.</sub> = rated torque of the coupling T<sub>KN</sub> x 2. For selection see page 14 et seqq.

<sup>6)</sup> The maximum speed depends on the size of brake disk and the maximum perm. circumferential speed. Observe specifications of the brake manufacturer.

<sup>7)</sup> Other sizes of brake disks on request. Cranked brake disks are available on request of the customer, too.

Ordering example:	GEARex® FBR 10	d <sub>1</sub> Ø50	d <sub>2</sub> Ø50	E <sub>A</sub> = 16	Ø300 x 12.7
		Type and size of coupling	Finish bore with keyway to DIN 6885 sheet 1	Finish bore with keyway to DIN 6885 sheet 1	Configuration of hubs with shaft distance dimension E

Type FBR  
with hub configuration A

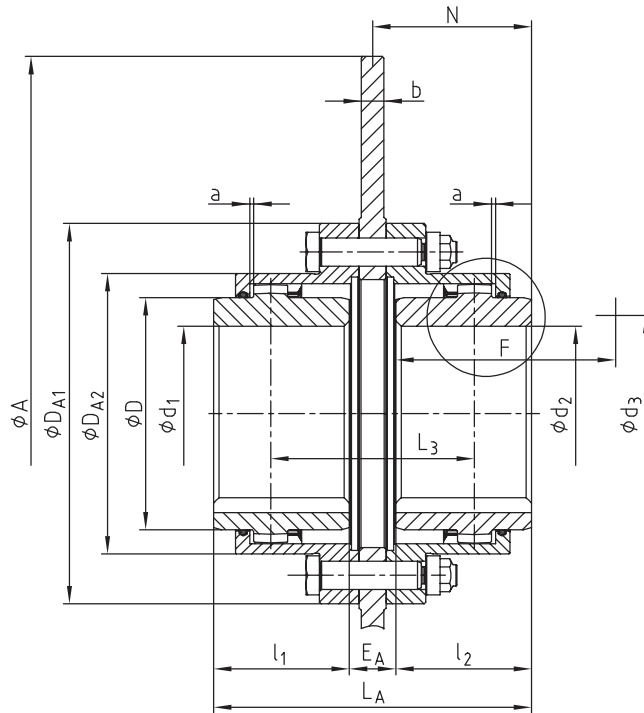

Types:

Type FBR

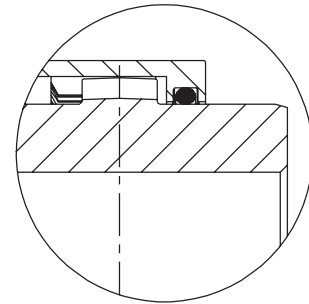

Type DBR

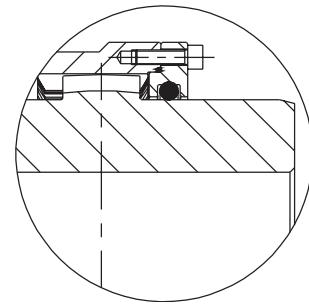

Type FBR  
with hub configuration B

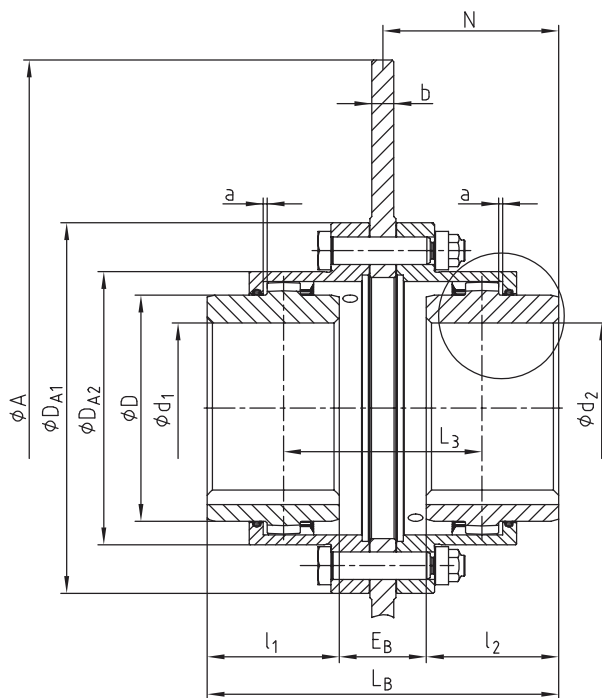

# GEARex® FH and DH

## All-steel gear couplings

Large shaft distance dimension, high power density

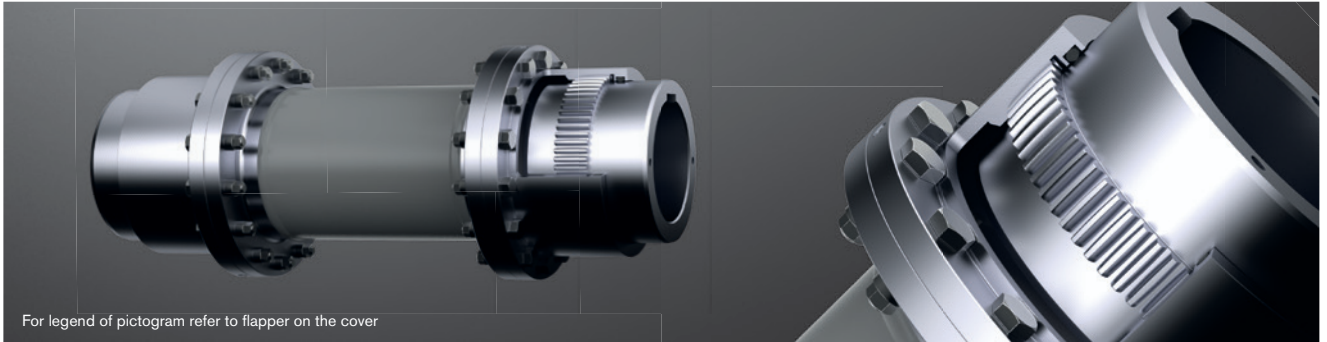

For legend of pictogram refer to flapper on the cover

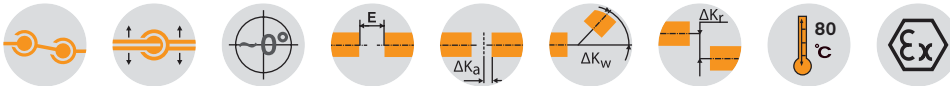

Dimensions																
Size <sup>3)</sup>	Torque [Nm] <sup>4)</sup>		Pilot bore	Max. finish bore		Dimensions [mm]								Dowel screw (10.9)		
	T <sub>KN</sub>	T <sub>KN</sub> (42CrMo4)		d <sub>1</sub> , d <sub>2</sub>	l <sub>1</sub> , l <sub>2</sub>	Hub lengthened max. l <sub>1</sub> , l <sub>2</sub>	D	DA1 <sup>2)</sup>	DA2 <sup>2)</sup>	L <sub>H</sub>	E <sub>H</sub>	F <sup>1)</sup>	d <sub>3</sub> <sup>1)</sup>	z	M	T <sub>A</sub> [Nm]
10	930	1580	26	50	43	105	67	111	83			74	52	6	M6	15
15	2000	3300	26	65	50	115	87	142	106			84	68	8	M8	36
20	3500	6300	31	82	62	130	108	174	129			107	85	6	M10	72
25	6500	11000	38	100	76	150	130	213	157			126	105	6	M12	125
30	10000	17400	44.5	115	90	170	153	240	181			148	125	8	M12	125
35	17000	28800	46	135	105	185	180	280	213			172	150	8	M14	200
40	28500	48500	52	160	120	215	214	318	249			192	175	8	M14	200
45	37000	62000	80	175	135	245	233	347	273			216	190	10	M14	200
50	51000	86000	80	195	150	295	260	390	308			241	220	8	M18	430
55	65000	110000	90	215	175	300	283	425.5	333			279	250	14	M18	430
60	85000	145000	100	240	190	305	312	457	364.5			316	265	14	M18	430
70	135000	240000	100	285	220	310	371	527	424			360	300	16	M20	610
80	175000	300000	140	300	280	-	394	545	475			360	358	18	M20	610
85	225000	380000	160	325	292	-	430	585	515			372	395	20	M20	610
90	-	500000	180	350	305	-	464	640	560			385	428	20	M24	1000
100	-	650000	220	390	330	-	512	690	612			410	465	24	M24	1000
110	-	820000	220	420	350	-	560	765	665			440	515	20	M30	1700
120	-	1050000	260	450	420	-	608	825	720			510	560	24	M30	1700
130	-	1450000	300	500	440	-	684	980	805			540	628	20	M36	2800
140	-	1950000	380	550	460	-	750	1055	875			560	695	24	M36	2800
150	-	2750000	460	630	520	-	850	1180	975			630	785	30	M36	2800

■ = Standard

<sup>1)</sup> Space required to align the coupling and replace the gasket

<sup>2)</sup> For dimensions of type F see page 108. For type D see page 104.

<sup>3)</sup> Size 10 and 15 available as type F only. From size 80 available as type D only.

<sup>4)</sup> Maximum torque of the coupling  $T_{K \max}$  = rated torque of the coupling  $T_{KN} \times 2$ . For selection see page 14 et seqq.

Ordering example:	GEARex® FH 10	d <sub>1</sub> Ø50	d <sub>2</sub> Ø50	250
	Type and size of coupling	Finish bore with keyway to DIN 6885 sheet 1	Finish bore with keyway to DIN 6885 sheet 1	Shaft distance dimension E <sub>H</sub>

Components

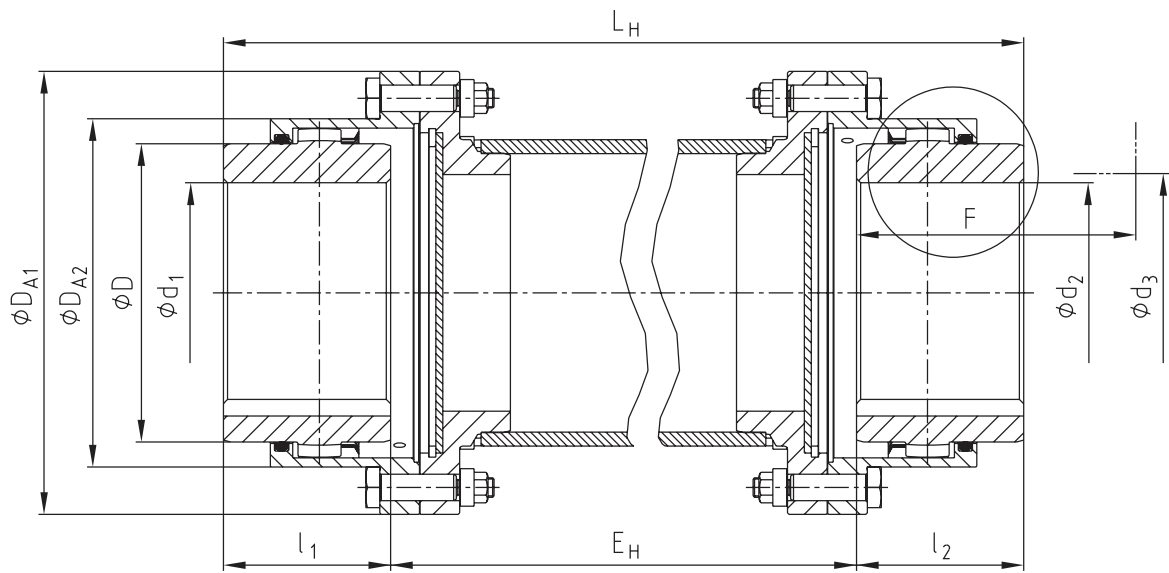

BoWex®

Types

Type FH

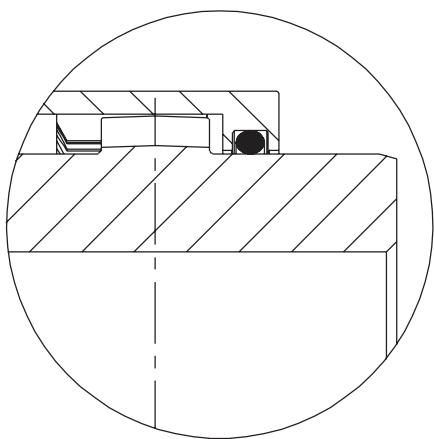

Type DH

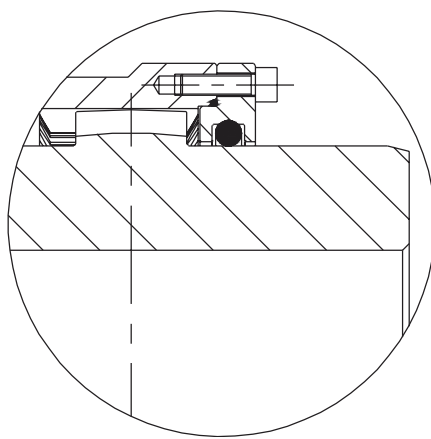

GEARex®

# GEARex® SD

## All-steel gear coupling

### Shiftable coupling with shiftable linkage (at standstill)



For legend of pictogram refer to flapper on the cover

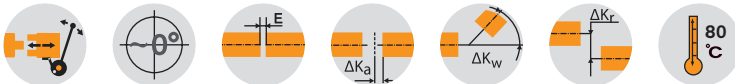

Dimensions												
Size	Torque $T_{KN}$ [Nm] <sup>1)</sup>	Max. finish bore		Dimensions [mm]								
		$d_1, d_2$	E	l1	l2	l3	L	n	D	$D_n$	$DA_1$	$DA_2$
10	1580	50	3	50	50	14	103	18	67	112.5	110	125
15	3300	65	3	60	60	20	123	20	87	131	132	145
20	6300	82	3	70	70	18	143	25	108	165	152	185
25	11000	100	5	80	80	20.5	165	30	130	210.5	183	230
30	17400	115	6	100	100	20	206	30	153	210.5	208	230
35	28800	135	6	110	110	22.5	226	35	180	250.5	238	270
40	48500	160	6	140	140	27.5	286	38	214	300.5	282	320
45	62000	175	8	150	150	27.5	308	38	233	300.5	302	320
50	86000	195	8	170	170	30	348	40	260	362	330	386
55	110000	215	10	190	190	40	390	40	283	362	354	386

Dimensions																					
Size	Shiftable linkage Size	Slip ring Size	Dimensions [mm]																		
			a	b	c	d3	d4	d5	e	F	g1	L2	L3	m	m1	m2	m3	m4	A	B	
10	3	3.3	140	60	25	30	13.5	20	40	120	70	490	600	100	310	20	90	44	140	180	
15	3	4.4	140	60	25	30	13.5	20	40	120	70	490	600	100	310	20	90	44	170	210	
20	4	5.5	160	60	25	35	13.5	30	50	147.5	70	565	750	120	365	30	100	54	200	244	
25	5	6.6	160	60	25	40	13.5	30	50	190	80	630	1025	120	410	30	110	62	250	300	
30	5	6.6	160	60	25	40	13.5	30	50	190	80	630	1025	120	410	30	110	62	300	350	
35	5	7.7	160	60	25	40	13.5	30	50	190	80	630	1085	120	410	30	110	62	300	350	
40	6	8.8	160	60	25	40	13.5	30	50	265	80	760	1068	120	540	30	110	62	360	420	
45	6	8.8	160	60	25	40	13.5	30	50	265	80	760	1068	120	540	30	110	62	360	420	
50	6	9.9	160	60	25	40	13.5	30	50	265	80	760	1068	120	540	30	110	62	420	480	
55	6	9.9	160	60	25	40	13.5	30	50	265	80	760	1068	120	540	30	110	62	420	480	

<sup>1)</sup> Maximum torque of the coupling  $T_{K max}$  = rated torque of the coupling  $T_{KN} \times 2$ . For selection see page 14 et seqq.

Max. circumferential speed  $v = 20$  m/s, referring to  $D_n$ .  
 Standard GEARex® SD couplings are not designed for continuous operation.  
 For displacement figures of the coupling refer to KTR standard 40311.

**On request:**

Other sizes or types for continuous operation available.  
 Shiftable linkage available with locking pins, locking device and retrieval of shift position.

<b>Ordering example:</b>	GEARex® 30 SD	$d_1$ Ø50	$d_2$ Ø55	6.6	5
	Size and type of coupling	Finish bore with keyway to DIN 6885 sheet 1		Slip ring Size	Shiftable linkage Size

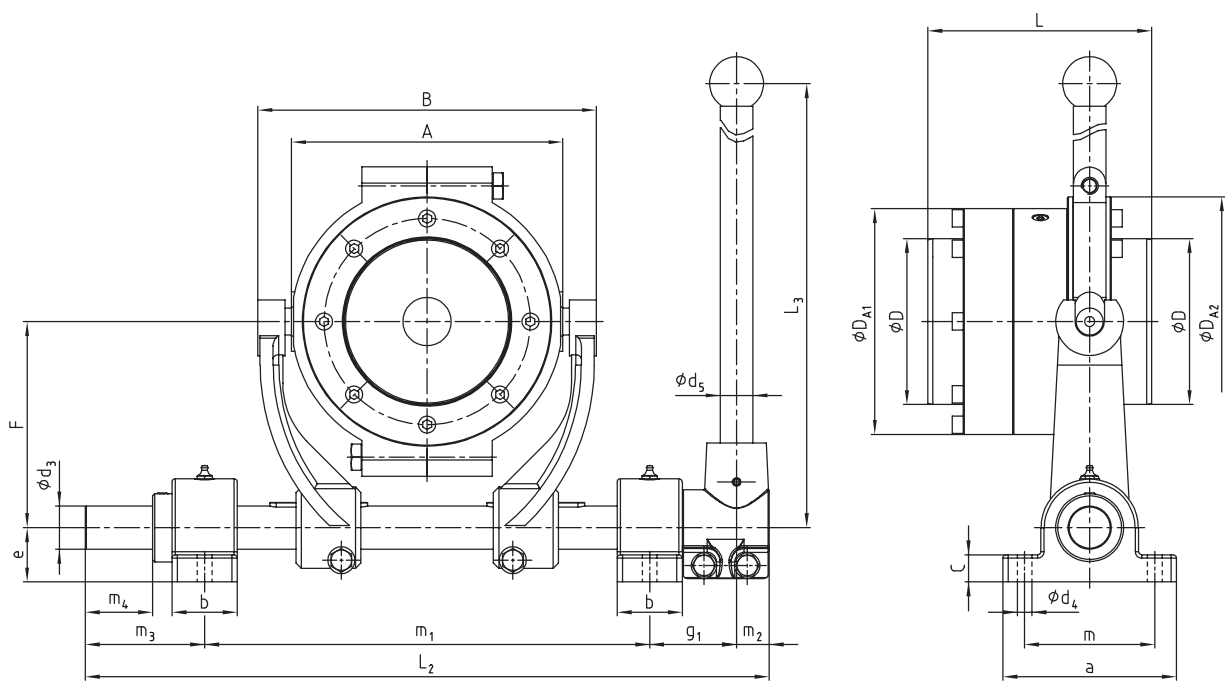
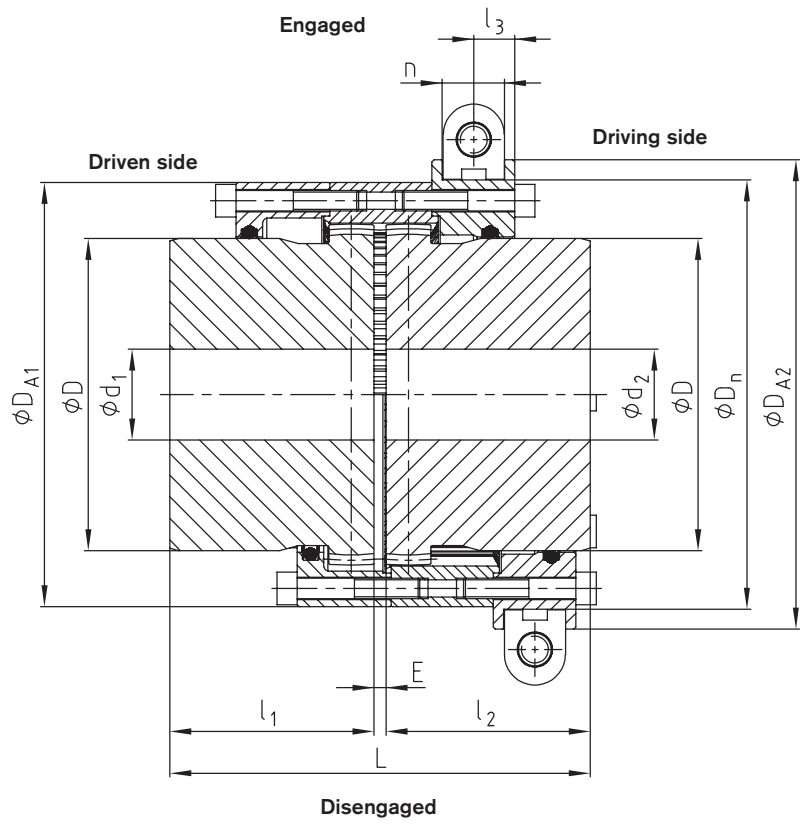

BoWex®

GEARex®

# GEARex® FR and DR

## All-steel gear couplings

Single-cardanic, high power density

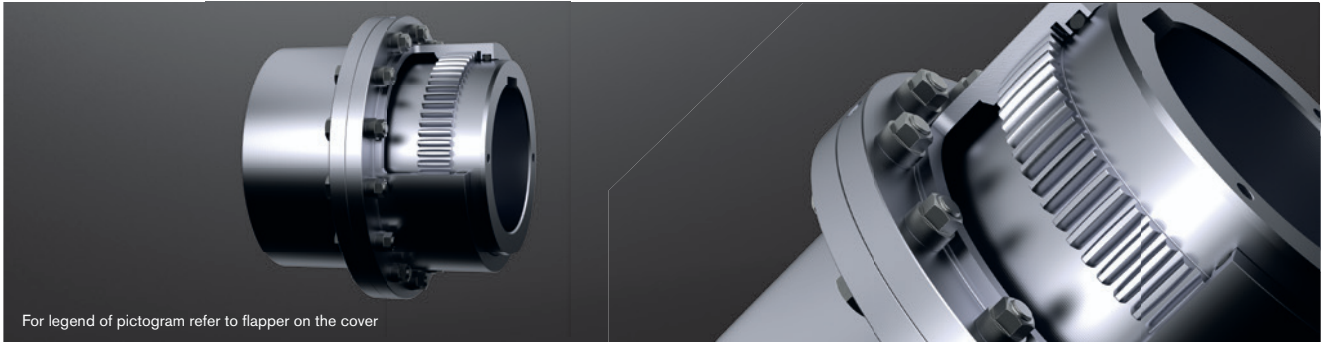

For legend of pictogram refer to flapper on the cover

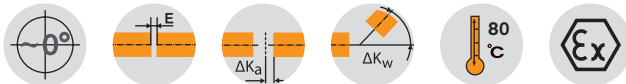

Dimensions																
Size <sup>3)</sup>	Torque [Nm] <sup>4)</sup>		Max. finish bore		Dimensions [mm]									Dowel screw (10.9)		
	T <sub>KN</sub>	T <sub>KN</sub> (42CrMo4)	d <sub>1</sub>	d <sub>4</sub>	l <sub>1</sub> , l <sub>2</sub>	Hub lengthened max. l <sub>1</sub> , l <sub>2</sub>	D	DA1 <sup>2)</sup>	DA2 <sup>2)</sup>	DF	L <sub>R</sub>	F <sup>1)</sup>	d <sub>g</sub> <sup>1)</sup>	z	M	T <sub>A</sub> [Nm]
10	930	1580	50	60	43	105	67	111	83	83	88	74	52	6	M6	15
15	2000	3300	65	78	50	115	87	142	106	106	103	84	68	8	M8	36
20	3500	6300	82	95	62	130	108	174	129	129	127	107	85	6	M10	72
25	6500	11000	100	115	76	150	130	213	157	157	157	126	105	6	M12	125
30	10000	17400	115	135	90	170	153	240	181	181	185	148	125	8	M12	125
35	17000	28800	135	155	105	185	180	280	213	213	216	172	150	8	M14	200
40	28500	48500	160	185	120	215	214	318	249	249	244	192	175	8	M14	200
45	37000	62000	175	200	135	245	233	347	273	273	276	216	190	10	M14	200
50	51000	86000	195	225	150	295	260	390	308	308	305	241	220	8	M18	430
55	65000	110000	215	245	175	300	283	425.5	333	333	356	279	250	14	M18	430
60	85000	145000	240	265	190	305	312	457	364.5	364.5	386	316	265	14	M18	430
70	135000	240000	285	310	220	310	371	527	424	424	450	360	300	16	M20	610
80	175000	300000	300	340	280	-	394	545	475	462	570	360	358	18	M20	610
85	225000	380000	325	370	292	-	430	585	515	500	597	372	395	20	M20	610
90	-	500000	350	400	305	-	464	640	560	546	623	385	428	20	M24	1000
100	-	650000	390	440	330	-	512	690	612	594	673	410	465	24	M24	1000
110	-	820000	420	480	350	-	560	765	665	647	710	440	515	20	M30	1700
120	-	1050000	450	520	420	-	608	825	720	700	852	510	560	24	M30	1700
130	-	1450000	500	560	440	-	684	980	805	760	890	540	628	20	M36	2800
140	-	1950000	550	610	460	-	750	1055	875	835	930	560	695	24	M36	2800
150	-	2750000	630	690	520	-	850	1180	975	935	1055	630	785	30	M36	2800

■ = Standard

<sup>1)</sup> Space required to align the coupling and replace the gasket

<sup>2)</sup> For dimensions of type F see page 108. For type D see page 104.

<sup>3)</sup> Size 10 and 15 available as type F only. From size 80 available as type D only.

<sup>4)</sup> Maximum torque of the coupling T<sub>K max</sub> = rated torque of the coupling T<sub>KN</sub> x 2. For selection see page 14 et seqq.

Ordering example:	GEARex® FR 10	d <sub>1</sub> Ø50	d <sub>4</sub> Ø60
	Type and size of coupling	Finish bore with keyway to DIN 6885 sheet 1	Finish bore with keyway to DIN 6885 sheet 1

Components

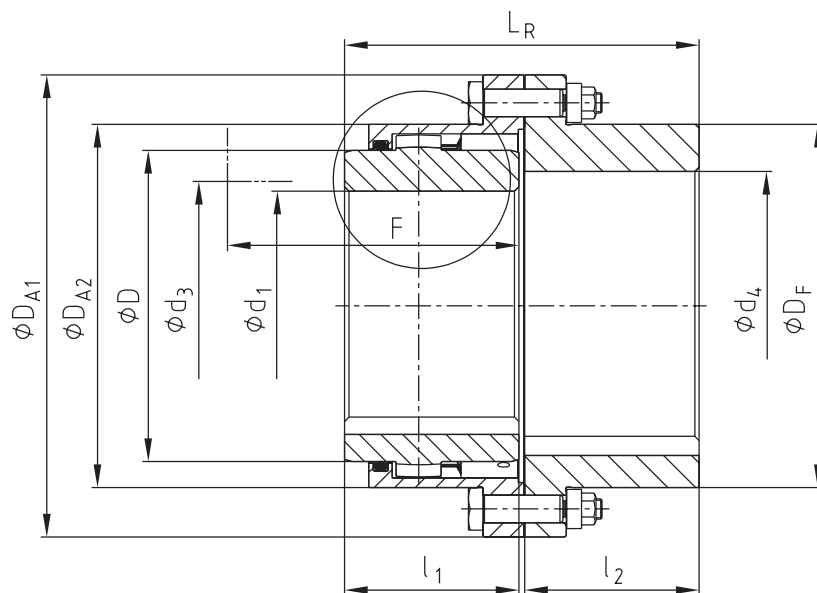

BoWex®

Types

Type FR

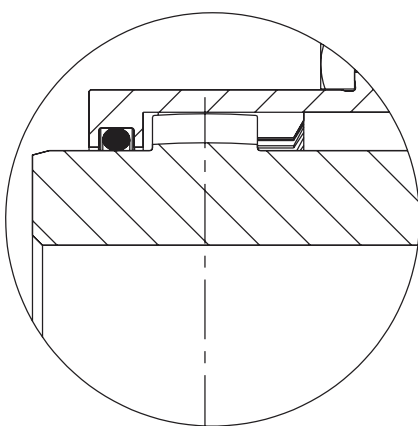

Type DR

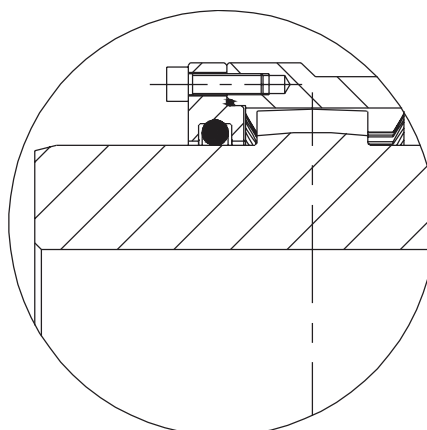

GEARex®

### Displacements

Axial displacement

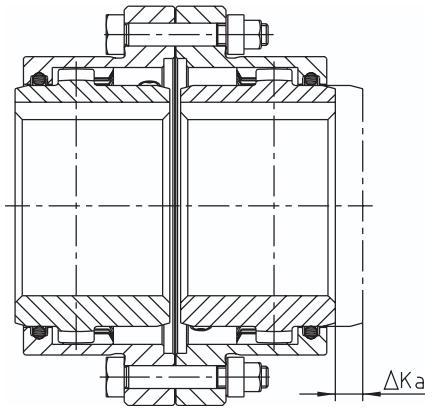

Radial displacement

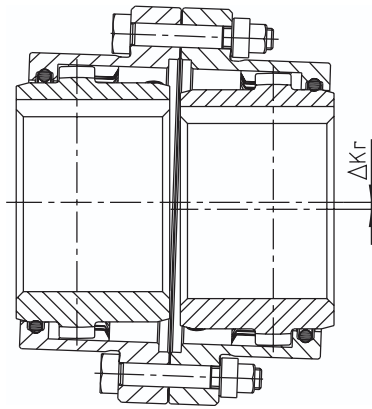

Angular displacement

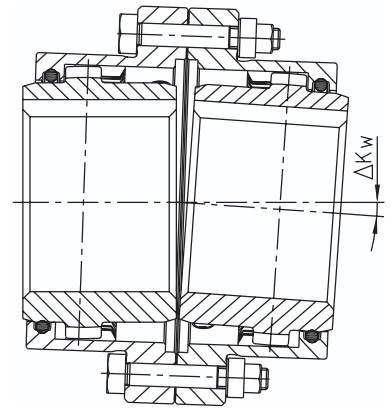

Displacements			
Size	Max. axial displacement $\Delta K_a$ [mm]	Max. permissible displacements <sup>1)</sup>	
		$\Delta K_r$ [mm]	$\Delta K_w$ [°]
10		± 0.4	
15		± 0.5	
20		± 0.6	
25	± 1.0	± 0.8	
30		± 1.0	
35		± 1.0	
40		± 1.2	
45		± 1.4	
50		± 1.6	
55	± 1.5	± 1.8	
60		± 2.0	0.5° each hub
70		± 2.2	
80		± 2.5	
85		± 2.8	
90	± 2.0	± 3.0	
100		± 3.2	
110		± 4.4	
120		± 5.5	
130		± 5.7	
140	± 2.5	± 6.0	
150		± 6.6	

<sup>1)</sup> The displacement figures are maximum figures which must not arise in parallel. If radial and angular displacements arise in parallel, the figures need to be reduced (see examples of calculation and diagramme).

Example 1:  
 $\Delta K_r = 30\%$   
 $\Delta K_w = 70\%$

Example 2:  
 $\Delta K_r = 60\%$   
 $\Delta K_w = 40\%$

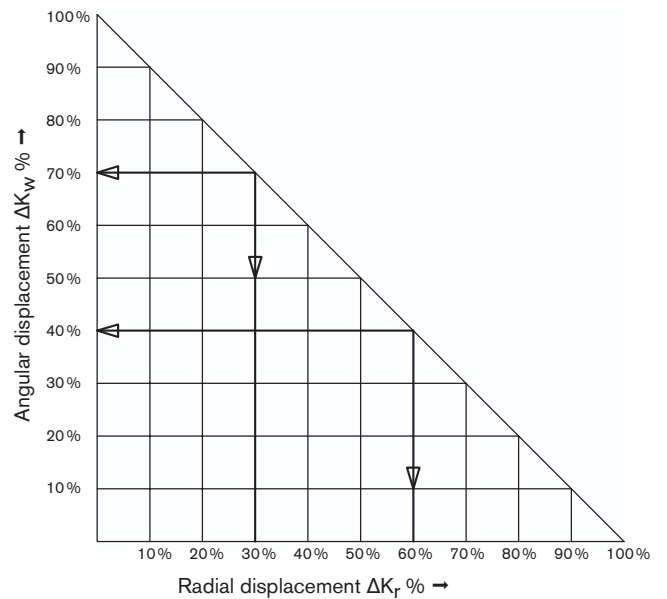

**Flange dimensions in accordance with AGMA 9008-B00**

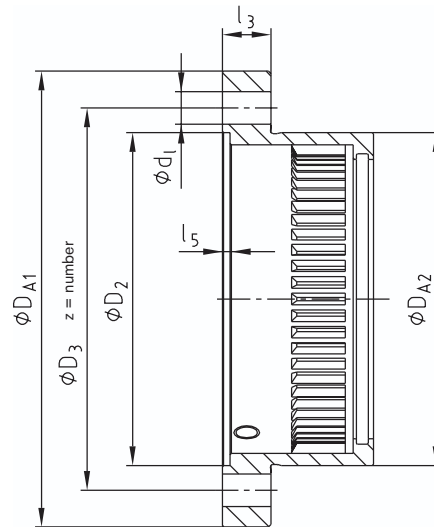

Flange dimensions								
Size	Dimensions [mm]							
	$D_{A1}$	$D_{A2}$	$D_2$	$D_3$	$d_1$	$z = \text{number}$	$l_3$	$l_5$
10	111	83	82	95.25	6.35	6	14	3
15	142	106	105	122.24	9.52	8	19	3
20	174	129	130	149.23	12.70	6	19	3
25	213	157	153	180.97	15.87	6	22	4
30	240	181	178	206.38	15.87	8	22	4
35	280	213	205	241.30	19.05	8	28.5	5
40	318	249	243	279.40	19.05	8	28.5	4
45	347	273	265	304.80	19.05	10	28.5	5.5
50	390	308	302	342.90	22.22	8	38	6
55	425.5	333	320	368.30	22.22	14	38	6
60	457	364.5	353	400.05	22.22	14	26	6
70	527	424	412	463.55	25.40	16	28.5	8

**Other types**

Type I (with one-piece sleeve)

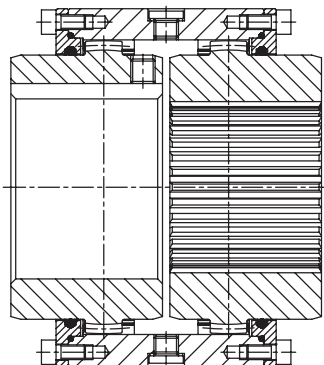

Type BK (with shear pins)

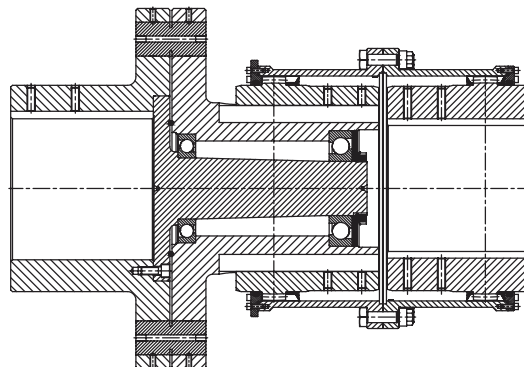

Type VD (for vertical assembly)

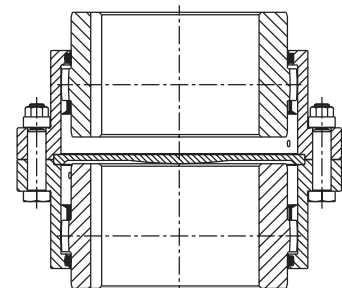



# Backlash-free servo couplings

Types and operating description 118

<b>ROTEX® GS</b>		<b>TOOLFLEX®</b>	
Technical description	120	Technical description	148
Technical data and displacements	122	Types of hubs	149
Types of hubs	126	Type S with setscrew	150
Stock programme	127	Type M with setscrew	151
Standard types	128	Type S with clamping hubs	152
Type Compact	130	Type M with clamping hubs	154
Type clamping ring hubs light	132	Type PI	156
Type clamping ring hubs steel	133	Type S-H / M-H	158
Type P according to DIN 69002	134	Type ZR	160
Type HP	136		
Type P with ETP® clamping set	138	<b>RADEX®-NC</b>	
Type with expansion hub for hollow shaft connections	139	Technical description	162
Type A-H drop-out center design couplings	140	Laminae sets and hub types	163
Type DKM (double-cardanic)	142	Type DK and EK with clamping hub 2.5/2.6	164
Type ZR3	144	Type DK and EK with clamping hub 3.5/3.6	165
Type ZRS intermediate shaft couplings	145	Type DK and EK with clamping ring hub 6.5	166
Type ZR1 and ZR2 intermediate shaft couplings	146	Type ZR with clamping hub type DH 7.5	168

Backlash-free servo couplings

ROTEX® GS



ROTEX® GS HP

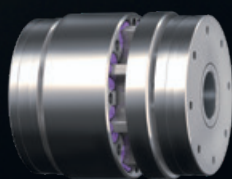

TOOLFLEX®





RADEX®-NC



# BACKLASH-FREE SERVO COUPLINGS

## TYPES AND OPERATING DESCRIPTION

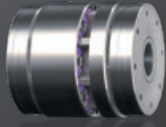
### Properties of backlash-free couplings

				
Product	ROTEX* GS / GS-P	ROTEX* GS HP	TOOLFLEX*	RADEX*-NC
Type	Jaw coupling	High-speed coupling	Metal bellow-type coupling	Servo laminae coupling
Properties				
Backlash-free	●	●	●	●
Torsionally stiff			●	●
Damping vibrations	●	●		
Maintenance-free	●	●	●	●
Axial plug-in	●	●	Optionally	
Compensating for misalignment	●	●	●	●
Electrical insulation	●	●		
Fail-safe	●	●		
Shear type			●	
Special features				
Applications	Backlash-free drives			
Core industries	Machine tools, automation technology, drive technology, medical technology, packaging technology	Machine tools, drive technology, test bench technology	Drive technology, automation technology, medical technology, packaging technology, machine tools	Automation technology, drive technology, packaging technology, machine tools, medical technology
Applications	Main spindles Control & positioning technology (screw drives with pitch $s < 40$ , otherwise review by KTR) Gearboxes (for medium to high transmission $i \geq 7$ ) Measuring and testing technology Miniature drives	Main spindles, test benches, high-speed applications, measuring technology	Gearboxes (transmissions $i < 7$ ) Miniature drives Control & positioning technology (screw drives with pitch $s \geq 40$ )	Gearboxes (transmissions $i < 7$ ) Measuring & testing technology Miniature drives Control & positioning technology (screw drives with pitch $s \geq 40$ )
Variation of components	very high	low	medium	medium
Torque range $T_{KN}$ [Nm]				
Min.	0.2	100	0.1	2.5
Max.	5,850	1340	600	3200
Max. circumferential speed $v$ [m/s]				
Steel	depending on hub type up to 40	175	depending on hub type up to 40	35
	80 (type P)			
	175 (type HP)			
Aluminium	depending on hub type up to 50			depending on hub type up to 75
Torsion spring stiffness $C_T$ [Nm/rad]				
Up to	1,308,850	472,300	322,740	1,050,000
Radial spring stiffness $C_r$ [N/mm]				
Up to	20,290	19,600	1,365	
Spiders / bellow / laminae / spacer				
Material	Polyurethane, Hytrel	Polyurethane	Stainless steel	Stainless steel
Elastomer hardness	flexible to torsionally stiff	flexible to torsionally stiff	-	-
Temperature range [°C] min./max.	-50/+120	-30/+90	-30/+100 (bonded)	-30/+200
			-30/+200 (flanged/welded)	
Geometries				
Design	compact	compact	compact, short	compact, short
Mass moment of inertia	low	low	low	low
Shaft distance dimension	medium	medium	medium	medium
Shaft-hub-connection				
Positive-locking	●	Optionally	Optionally	Optionally
Non-positive (frictionally engaged)	●	●	●	●

● ≈ Standard

# BACKLASH-FREE SERVO COUPLINGS TYPES AND OPERATING DESCRIPTION

## Product finder of backlash-free couplings

Product	ROTEX® GS	ROTEX® GS HP	TOOLFLEX®	RADEX®-NC
Type	Jaw coupling	High-speed coupling	Metal bellow-type coupling	Servo laminae coupling
<b>Types (extract)</b>				
Elastomers can be radially disassembled » without displacing driving/driven side	A-H	-	-	-
Intermediate shaft types » bridging larger shaft distances	ZR1, ZR2, ZR3	-	ZR	ZR
shaft-to-shaft connection	Standard	Standard	Standard	Standard
flange-to-shaft connection	CFN, DFN, CF-DKM	CF	CF	-
Flange-to-flange connection » particularly short mounting length	Optionally	Optionally	Optionally	-
Single-cardanic	Standard	Standard	-	EK
Double-cardanic » compensating for big displacements » lower restoring forces	DKM	-	Standard	DK
<b>Certifications</b>				
ATEX		●		●

● ≈ Standard

## Torsion angle

The diagramme alongside this text explains the impact of ROTEX®, ROTEX® GS, RADEX®-NC and TOOLFLEX® couplings on backlash and torsion angle. Due to the high torsion spring stiffness of RADEX®-NC and TOOLFLEX®, the torsion angle is very low under torque. However, contrary to the flexible ROTEX® and the backlash-free ROTEX® GS damping of torsional vibrations etc. is not possible.

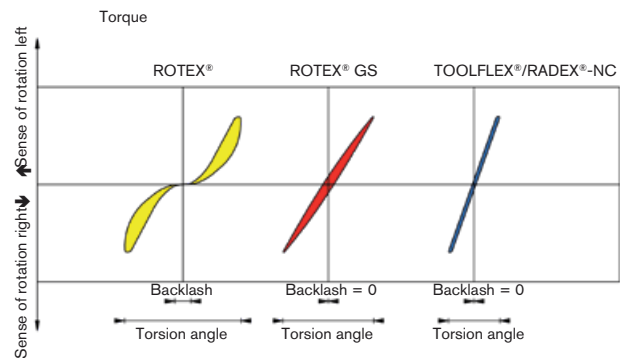

# ROTEX® GS

## Backlash-free jaw couplings

### Technical description



**ROTEX® GS** is a three-part, axial plug-in coupling backlash-free under prestress. It impresses even with critical applications by its backlash-free torque transmission, its stiffness which is each adapted to the application and its optimum damping of vibrations. Using this principle provides for particularly assembly-friendly options optimizing the assembly times in production.

The straight spline of the spider mounted under prestress results in a lower surface pressure and consequently higher stiffness of the coupling system. The flexible teeth compensating for misalignment are radially supported in the internal diameter by a web. This avoids too high internal or external deformation with high acceleration resp. high speeds. This is vital for a smooth operation and long service life of the coupling.

The pegs on the spider arranged reciprocally prevent contact of the spider on the hubs over the full surface. Observing the distance dimension E ensures the coupling's ability to compensate for displacements.

Observing the gap dimension „s“ ensures electrical insulation as well as a long service life of the coupling. This is gaining more and more importance, due to the increasing precision of shaft encoders and the existing demand for electromagnetic compatibility (EMC).

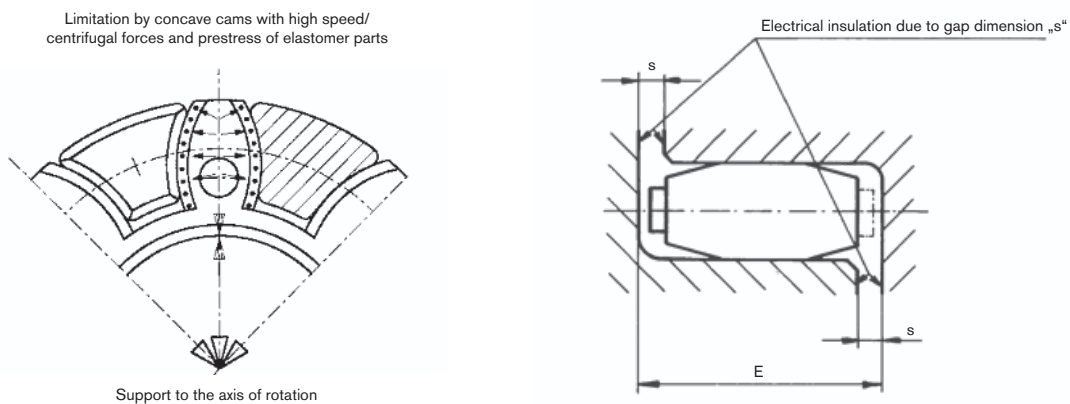

#### Advice

- Feather keyways available from a bore  $\geq \text{Ø}6$ . Feather keyways according to DIN 6885 sheet 1, tolerance JS9.
- Finish bore tolerance H7 (except for clamping hubs), from  $\text{Ø}55$  G7 with clamping ring hubs
- Finish bore tolerance H6 for ROTEX® GS P and ROTEX® GS HP
- Recommended insertion dimension of shafts in the coupling hubs:  $l_1/l_2$ ; for clamping ring hubs the minimum insertion dimension  $l_3$  applies
- Spider with bore available on request. Please specify in the order as shown in the example on page 130.

#### Use in potentially explosive atmospheres

ROTEX® GS couplings are suitable for power transmission in drives intended for use in potentially explosive atmospheres. The couplings are assessed and approved as units of category 2G/2D according to EU directive 2014/34/EU and thus suitable for the use in potentially explosive atmospheres of zone 1, 2, 21 and 22. Please read through our information included in the respective type examination certificate and the operating and assembly instructions at [www.ktr.com](http://www.ktr.com).

Selection: If used in potentially explosive atmospheres, the clamping ring hubs (clamping hubs without feather keyway only for use in category 3) must be selected in that there is a minimum safety factor of  $s = 2$  between the peak torque of the machine including all operating parameters and the nominal torque and frictional locking torque of the coupling.

### Technical description

**ROTEX® GS HP** is a backlash-free, axial plug-in, flexible jaw coupling developed for high-speed drives.

In contrast to the ROTEX® GS coupling this type has individual elastomers instead of a connected spider.

This allows to design the hubs as a completely enclosed shape so that both the cam section and the pocket part feature higher stiffness against loads in the direction of rotation (torque shocks), but also in tangential direction (centrifugal force). The elastomers are embedded in the pocket part in a way that the high loads resulting from centrifugal forces do not have any negative influence on them and consequently on the overall drive system.



Instead of speeds with circumferential speeds of a maximum of 100 m/s for the ROTEX® GS P couplings, circumferential speeds up to 175 m/s can be reached with the new ROTEX® GS HP system.







# ROTEX® GS



## Backlash-free jaw couplings

### Spiders

The flexible spiders for the GS series are available in seven different kinds of Shore hardness, injected in different colours, either as a torsionally soft or hard material. These five spiders with different kinds of Shore hardness allow to easily adjust the ROTEX® GS to the individual conditions of an application considering the torsional spring stiffness and the vibration characteristics. The flexible prestress varies depending on the coupling size, the spiders/materials and the production tolerances. Resulting from it is the axial plug-in force starting from low as a close sliding fit resp. with torsionally soft spider to heavy with big prestress resp. torsionally rigid spider (see operating/assembly instruction KTR-N 45510 at [www.ktr.com](http://www.ktr.com)).

Along with an increasing hardness of the spider the torques to be transmitted and the stiffness of the spider increase, too. Along with reduced hardness of the spider, the ability of compensating for displacements and damping of the spider increases.

Properties of ROTEX® GS spiders						
Description of spider hardness [Shore]	Marking of colour	Material	Perm. temperature range [°C]		Available for coupling size	Typical applications
			Permanent temperature <sup>1)</sup>	Max. temperature (short-time) <sup>1)</sup>		
80 ShA-GS		Polyurethane	-50 to +80	-60 to +120	Size 5 to 19	- drives of electrical measuring systems
92 ShA-GS		Polyurethane	-40 to +90	-50 to +120	Size 5 to 38	- drives of electrical measuring and control systems - main spindle drives
98 ShA-GS		Polyurethane	-30 to +90	-40 to +120	Size 5 to 90	- Positioning drives - main spindle drives - high load
52 ShD-S-GS <sup>2)</sup>		Polyurethane	-40 to +120	-50 to +150	Size 24 to 42	- Positioning drives with increased temperature - 40 % of torque benefit from 60 °C - Permanently pressure-resistant up to 120 °C
57 ShD-GS		Polyurethane	-30 to +90	-40 to +120	Size 19 to 65	- Positioning drives - main spindle drives - high load
64 ShD-H-GS 64 ShD-GS		Hytrell	-50 to +120	-60 to +150	Size 7 to 38	- planetary gears/backlash-free gears - higher torsion spring stiffness
		Polyurethane	-20 to +110	-30 to +120	Size 42 to 90	- higher load - higher torsion spring stiffness
72 ShD-H-GS 72 ShD-GS		Hytrell	-50 to +120	-60 to +150	Size 24 to 38	- very high torsion spring stiffness - very high load
		Polyurethane	-20 to +110	-30 to +120	Size 42 to 90	- very high torsion spring stiffness - very high load

Properties of ROTEX® GS HP tooth elements						
Description of spider hardness [Shore]	Marking of colour	Material	Perm. temperature range [°C]		Available for coupling size	Typical applications
			Permanent temperature	Max. temperature (short-time)		
98 ShA-GS 52 ShD-GS		Polyurethane	-30 to +90	-40 to +120	Size 24 to 65 (for ROTEX® GS HP only)	- HSC main spindle drives - test benches with severely high speeds
65 ShD-GS		Polyurethane	-30 to +90	-40 to +120	Size 24 to 65 (for ROTEX® GS HP only)	- HSC main spindle drives - test benches with severely high speeds - higher load - higher torsion spring stiffness

<sup>1)</sup> The temperature factors specified on page 23 must be considered.

<sup>2)</sup> Torques and displacements same as with 98 ShA-GS spider

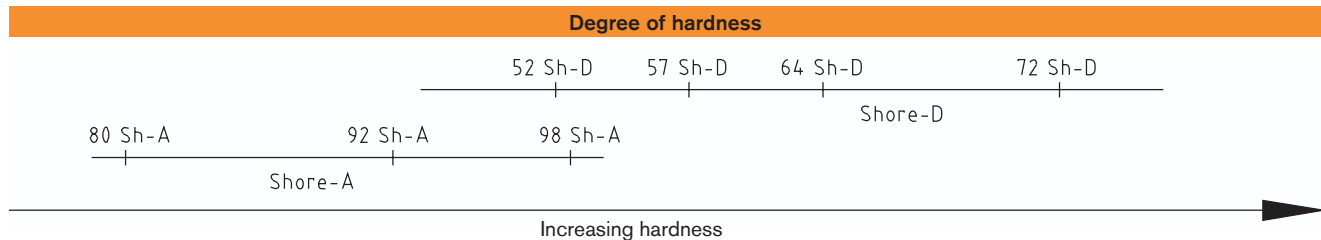

Spider material	Polyurethane					Hytrell
Degree of hardness	92 Shore A	98 Shore A	52 Shore D	57 Shore D	64 Shore D	64 Shore D
Relative damping $\psi$ [-] <sup>1)</sup>	0.80	0.80	0.75	0.75	0.75	0.60
Resonance factor $V_R$ [-] <sup>1)</sup>	7.90	7.90	8.50	8.50	8.50	10.5

<sup>1)</sup> Special figures apply for ROTEX® GS HP, please contact us.

# ROTEX® GS

## Backlash-free jaw couplings

### Technical data

Size	Spider GS Shore hardness	Shore scale	Max. speed [rpm] for type					Torque [Nm]		Static torsion spring stiffness <sup>1)</sup> [Nm/rad]	Dynamic torsion spring stiffness <sup>1)</sup> [Nm/rad]	Radial spring stiffness C <sub>r</sub> [N/mm]	Weight [kg]		Mass moment of inertia J [kgm <sup>2</sup> ]		
			2.0/2.1 2.5/2.6	2.8 2.9	1.0 1.1	6.0 light <sup>2)</sup>	6.0 P <sup>2)</sup>	DKM	T <sub>KN</sub>				T <sub>K max</sub>	Per hub <sup>5)</sup>	Spider	Per hub <sup>5)</sup>	Spider
5	80 A	A	38000	38000	47700			57300	0.3	0.6	3.15	10	82	0.001	0.2 x 10 <sup>-3</sup>	0.015 x 10 <sup>-6</sup>	0.002 x 10 <sup>-6</sup>
	92 A	A							0.5	1.0	5.16	16	154				
	98 A	A							0.9	1.7	8.3	25	296				
7	80 A	A	27000	27000	34100			40900	0.7	1.4	8.6	26	114	0.003	0.7 x 10 <sup>-3</sup>	0.085 x 10 <sup>-6</sup>	0.01 x 10 <sup>-6</sup>
	92 A	A							1.2	2.4	14.3	43	219				
	98 A	A							2.0	4.0	22.9	69	421				
8	64 D	D	23800						2.4	4.8	34.3	103	630	0.003	0.5 x 10 <sup>-3</sup>	0.117 x 10 <sup>-6</sup>	0.0124 x 10 <sup>-6</sup>
	80 A	A							0.7	1.4	8.8	27	117				
	98 A	A							2.0	4.0	23.5	71	433				
9	64 D	D	19000	19000	23800			28600	2.4	4.8	35.3	106	648	0.01	1.7 x 10 <sup>-3</sup>	0.48 x 10 <sup>-6</sup>	0.085 x 10 <sup>-6</sup>
	80 A	A							1.8	3.6	17.2	52	125				
	92 A	A							3.0	6.0	31.5	95	262				
12	98 A	A	15200	15200	19100			22900	5.0	10.0	51.6	155	518	0.02	2.3 x 10 <sup>-3</sup>	1.5 x 10 <sup>-6</sup>	0.139 x 10 <sup>-6</sup>
	64 D	D							9.0	18.0	240.7	718	846				
	80 A	A							3.0	6.0	84.3	252	274				
13	92 A	A	12700		38200				5.0	10.0	160.4	482	470	0.01	2.0 x 10 <sup>-3</sup>	1.1 x 10 <sup>-6</sup>	0.155 x 10 <sup>-6</sup>
	64 D	D							11.0	22.0	316	941	1109				
	80 A	A							3.6	7.2	111	330	359				
14	98 A	A	12700	12700	15900	32000	47700	19100	7.5	15.0	114.6	344	336	0.02	4.7 x 10 <sup>-3</sup>	2.8 x 10 <sup>-6</sup>	0.509 x 10 <sup>-6</sup>
	64 D	D							12.5	25.0	171.9	513	654				
	80 A	A							16.0	32.0	234.2	702	856				
16	98 A	A	12000						5.0	10.0	157	471	400	0.02	3.6 x 10 <sup>-3</sup>	2.8 x 10 <sup>-6</sup>	0.435 x 10 <sup>-6</sup>
	64 D	D							15.0	30.0	450	1341	1710				
	80 A	A							19.0	38.0	612	1835	2238				
19	92 A	A	9550	9550	11900	24000 19000 <sup>4)</sup>	35800	14300	6.0	12.0	618	1065	582	0.09	7.6 x 10 <sup>-3</sup>	19.5 x 10 <sup>-6</sup>	1.35 x 10 <sup>-6</sup>
	98 A	A							12.0	24.0	1090	1815	1120				
	57 D	D							21.0	42.0	1512	2540	2010				
24	64 D	D	6950	10400	8650	17000 14000 <sup>4)</sup>	26000	10400	23.0	46.0	2036	3175	2470	0.2	0.02	81.9 x 10 <sup>-6</sup>	6.7 x 10 <sup>-6</sup>
	92 A	A							35	70	2280	4010	1480				
	98 A	A							60	120	3640	5980	2560				
28	52 D	D	5850	8800	7350	15000 12000 <sup>4)</sup>	22000	8800	60	120	3640	5980	2560	0.3	0.03	184.2 x 10 <sup>-6</sup>	14.85 x 10 <sup>-6</sup>
	57 D	D							160	320	6410	9920	3200				
	64 D	D							180	360	8335	15050	3775				
38	72 <sup>3)</sup> D	D	4750	7150	5950	12000 9600 <sup>4)</sup>	17900	7150	200	400	10260	20177	4348	0.6	0.05	542.7 x 10 <sup>-6</sup>	39.4 x 10 <sup>-6</sup>
	92 A	A							260	520	21526	36547	7876				
	98 A	A							190	380	6525	11050	2350				
42	52 D	D	4000		5000	10000 8050 <sup>4)</sup>	15000	6000	325	650	11800	17160	4400	2.4	0.08	2802 x 10 <sup>-6</sup>	85 x 10 <sup>-6</sup>
	57 D	D							325	650	11800	17160	4400				
	64 D	D							365	730	19050	28745	5437				
48	72 <sup>3)</sup> D	D	3600		4550	9100 7200 <sup>4)</sup>	13600	5450	405	810	26300	40335	6474	3.3	0.09	4709 x 10 <sup>-6</sup>	135 x 10 <sup>-6</sup>
	98 A	A							525	1050	44584	71180	11425				
	52 D	D							450	900	21594	37692	5570				
55	57 D	D	3150		3950	6350 <sup>4)</sup>	11900	4750	495	990	29225	53760	6420	5.1	0.12	9460 x 10 <sup>-6</sup>	229 x 10 <sup>-6</sup>
	64 D	D							590	1180	41695	72685	7102				
	72 <sup>3)</sup> D	D							770	1540	68175	98065	8005				
65	98 A	A	2800		3500	5650 <sup>4)</sup>	11000		825	1650	105730	130200	9248	6.7	0.2	15143 x 10 <sup>-6</sup>	437 x 10 <sup>-6</sup>
	57 D	D							1072	2144	150000	209530	12762				
	64 D	D							940	1880	48520	71660	6418				
75	72 <sup>3)</sup> D	D	2350		2950	4750 <sup>4)</sup>	8950		1055	2110	78535	114175	7685	10.5	0.3	32750 x 10 <sup>-6</sup>	1179 x 10 <sup>-6</sup>
	98 A	A							1175	2350	118510	189189	8870				
	64 D	D							1527	3054	160000	310000	11826				
90	98 A	A	1900		2380	3800 <sup>4)</sup>	7150		1920	3840	79150	150450	8650	18.2	0.6	87099 x 10 <sup>-6</sup>	3362 x 10 <sup>-6</sup>
	64 D	D							2400	4800	182320	316377	11923				
	72 <sup>3)</sup> D	D							3120	6240	360540	586429	16454				
									3600	7200	204500	302900	10700				
									4500	9000	429450	908700	14700				
									5850	11700	847440	1308852	20290				

<sup>1)</sup> Static and dynamic torsion spring stiffness with 0.5 x T<sub>KN</sub>

<sup>2)</sup> For higher speeds see ROTEX® GS HP

<sup>3)</sup> When using the spider 72 ShD, we recommend to use hubs made of steel

<sup>4)</sup> Clamping ring hubs 6.0 made of steel

<sup>5)</sup> Hubs with an average bore type 1.0

The coupling has to be dimensioned in that the permissible coupling load is not exceeded during any operating condition (see coupling selection on page 22 et seqq.).

The specified torques T<sub>KN</sub>/T<sub>K max</sub> refer to the spider. The shaft-hub-connection needs to be verified by the customer.

# ROTEX® GS

## Backlash-free jaw couplings

### Hints for displacements

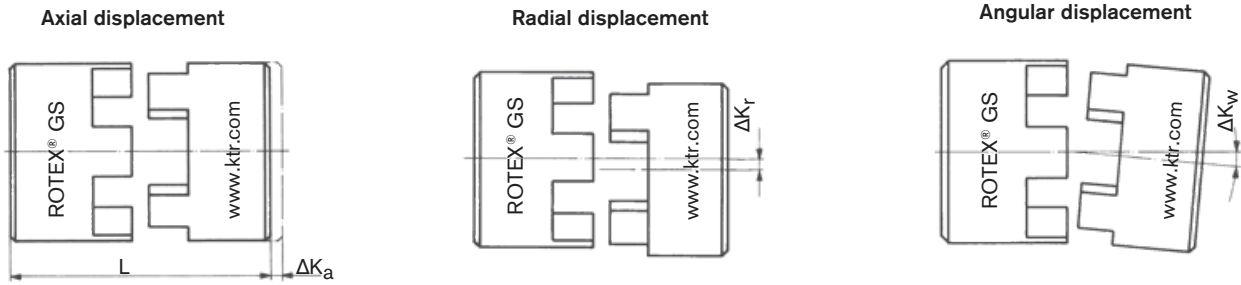

Due to its design the ROTEX® GS is able to absorb axial, angular and radial displacement, without causing any wear or premature failure of the coupling. As the spider is only stressed under pressure it is ensured that the coupling remains backlash-free even after a longer operation period.

For instance, axial displacement may be generated by different tolerances of the connecting elements with assembly or by alteration of the shaft lengths if temperature fluctuations occur. As the shaft bearings usually cannot be axially stressed to a big extent, it is the task of the coupling to compensate for this axial displacement and keep the reaction forces low.

In case of pure angular displacement the imaginary bisecting lines of the shafts intersect in the centre of the coupling. Within a permissible range this displacement can be absorbed by the coupling without extensive restoring forces being generated.

Radial displacement results from parallel displacement of the shafts to one another, caused by different tolerances on the centerings or by mounting the power packs on different levels. Due to the kind of displacement the largest restoring forces are generated here, consequently causing the highest stresses on adjacent components.

In case of larger displacements (especially radial displacements) the ROTEX® GS type DKM double-cardanic system should be used in order to avoid excessive restoring forces.

The permissible displacement figures of the flexible ROTEX® GS couplings specified are general standard values taking into account the load of the coupling up to the rated torque  $T_{KN}$  of the coupling and an ambient temperature of +30 °C. The displacement figures may only be used one by one, if they appear simultaneously, they must be limited in proportion. The ROTEX® GS couplings are able to absorb axial, radial and angular displacements. Careful and accurate alignment of the shafts increases the service life of the coupling.

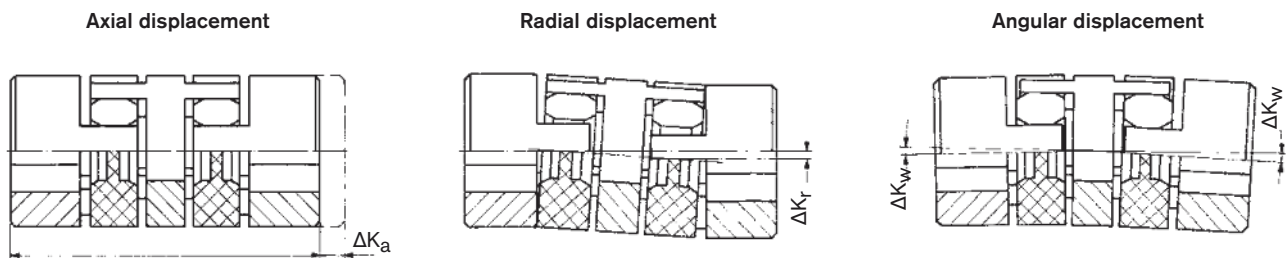

#### Shaft misalignment of ROTEX® GS type DKM

This design reduces the restoring forces arising with radial displacement to a minimum, due to the double-jointed operation, additionally the coupling is able to compensate for higher axial and angular misalignment.

# ROTEX® GS

## Backlash-free jaw couplings

### Displacements

Displacements							
Size	Spider GS	Standard displacements			DKM displacements		
		Axial $\Delta K_a^{1)}$ [mm]	Radial $\Delta K_r$ [mm]	Angular $\Delta K_w$ [degree]	Axial $\Delta K_a^{1)}$ [mm]	Radial $\Delta K_r$ [mm]	Angular $\Delta K_w$ [degree]
5	80 ShA		0.12	1.1°		0.15	1.1°
	92 ShA	-0.2	0.06	1.0°	-0.4	0.14	1.0°
	98 ShA		0.04	0.9°		0.13	0.9°
7	80 ShA		0.15	1.1°		0.23	1.1°
	92 ShA	+0.6	0.10	1.0°	+0.6	0.21	1.0°
	98 ShA	-0.3	0.06	0.9°	-0.6	0.19	0.9°
8	64 ShD		0.04	0.8°		0.17	0.8°
	80 ShA		0.15	1.1°			
	98 ShA	+0.6	0.08	0.9°	—	—	—
9	64 ShD	-0.5	0.06	0.8°			
	80 ShA		0.19	1.1°		0.29	1.1°
	92 ShA	+0.8	0.13	1.0°	+0.8	0.26	1.0°
12	98 ShA	-0.4	0.08	0.9°	-0.8	0.24	0.9°
	64 ShD		0.05	0.8°		0.21	0.8°
	80 ShA		0.20	1.1°		0.35	1.1°
13	92 ShA	+0.9	0.14	1.0°	+0.9	0.32	1.0°
	98 ShA	-0.4	0.08	0.9°	-0.9	0.29	0.9°
	64 ShD		0.05	0.8°		0.25	0.8°
14	80 ShA		0.20	1.1°			
	92 ShA	+0.9	0.14	1.0°	+0.9	0.32	1.0°
	98 ShA	-0.4	0.08	0.9°	-0.9	0.29	0.9°
16	64 ShD		0.05	0.8°		0.25	0.8°
	80 ShA		0.21	1.1°		0.40	1.1°
	92 ShA	+1.0	0.15	1.0°	+1.0	0.37	1.0°
19	98 ShA	-0.5	0.09	0.9°	-1.0	0.33	0.9°
	64 ShD		0.06	0.8°		0.29	0.8°
	80 ShA		0.21	1.1°			
24	98 ShA	+0.9	0.08	0.9°	—	—	—
	64 ShD	-0.8	0.05	0.8°			
	80 ShA		0.15	1.1°		0.49	1.1°
28	92 ShA	+1.2	0.10	1.0°	+1.2	0.45	1.0°
	98 ShA	-0.5	0.06	0.9°	-1.0	0.41	0.9°
	57 ShD		0.05	0.85°		0.38	0.85°
38	64 ShD		0.04	0.8°		0.36	0.8°
	92 ShA		0.14	1.0°		0.59	1.0°
	98 ShA	+1.4	0.10	0.9°	+1.4	0.53	0.9°
42	57 ShD	-0.5	0.08	0.85°	-1.0	0.50	0.85°
	64 ShD		0.07	0.8°		0.47	0.8°
	72 ShD		0.04	0.7°		0.42	0.7°
48	92 ShA		0.15	1.0°		0.66	1.0°
	98 ShA	+1.5	0.11	0.9°	+1.5	0.60	0.9°
	57 ShD	-0.7	0.09	0.85°	-1.4	0.56	0.85°
55	64 ShD		0.08	0.8°		0.53	0.8°
	72 ShD		0.05	0.7°		0.46	0.7°
	92 ShA		0.17	1.0°		0.77	1.0°
65	98 ShA	+1.8	0.12	0.9°	+1.8	0.69	0.9°
	57 ShD	-0.7	0.10	0.85°	-1.4	0.65	0.85°
	64 ShD		0.09	0.8°		0.61	0.8°
75	72 ShD		0.06	0.7°		0.54	0.7°
	98 ShA		0.14	0.9°		0.75	0.9°
	57 ShD	+2.0	0.12	0.85°	+2.0	0.71	0.85°
90	64 ShD	-1.0	0.10	0.8°	-2.0	0.67	0.8°
	72 ShD		0.07	0.7°		0.59	0.7°
	98 ShA		0.16	0.9°		0.82	0.9°
90	57 ShD	+2.1	0.13	0.85°	+2.1	0.77	0.85°
	64 ShD	-1.0	0.11	0.8°	-2.0	0.73	0.8°
	72 ShD		0.08	0.7°		0.64	0.7°
90	98 ShA		0.17	0.9°	+2.2	0.91	0.9°
	57 ShD	+2.2	0.14	0.85°	-2.0	0.86	0.85°
	64 ShD	-1.0	0.12	0.8°		0.81	0.8°
90	72 ShD		0.09	0.7°		0.71	0.7°
	98 ShA		0.18	0.9°			
	57 ShD	+2.6	0.15	0.85°	—	—	—
90	64 ShD	-1.0	0.13	0.8°			
	72 ShD		0.10	0.7°			
	98 ShA		0.21	0.9°			
90	64 ShD	+3.0	0.15	0.8°	—	—	—
	72 ShD	-1.5	0.11	0.7°			
	98 ShA		0.23	0.9°			
90	64 ShD	+3.4	0.17	0.8°	—	—	—
	72 ShD	-1.5	0.13	0.7°			

<sup>1)</sup> The  $K_a$  figures specified have to be added to the length of the respective coupling type.

The displacement figures may only be used one by one, if they appear simultaneously, they must be limited in proportion. Care should be taken to maintain the distance dimension E accurately in order to allow for axial clearance of the coupling while in operation. Detailed mounting instructions are shown on our homepage [www.ktr.com](http://www.ktr.com).

For technical data of type HP see page 136.

# ROTEX® GS

## Backlash-free jaw couplings

### Displacements of intermediate shaft coupling

Displacements of intermediate shaft couplings			
ROTEX® GS size (with 98 ShA-GS)	Axial $\Delta K_a$ [mm]	Radial $\Delta K_r$ <sup>1)</sup> [mm]	Angular $\Delta K_w$ [degree]
14	+1.0	15	0.9°
	-1.0		
19	+1.2	14	0.9°
	-1.0		
24	+1.4	14	0.9°
	-1.0		
28	+1.5	14	0.9°
	-1.4		
38	+1.8	14	0.9°
	-1.4		
42	+2.0	14	0.9°
	-2.0		
48	+2.1	13	0.9°
	-2.0		
55	+2.2	13	0.9°
	-2.0		
65	+2.6	13	0.9°
	-2.0		

<sup>1)</sup> Radial displacements based on a coupling length  $L_{ZR} = 1000$  mm

Calculation of overall torsion spring stiffness:

$$C_{tot.} = 2 \cdot \frac{1}{C_1} + \frac{L_{pipe}}{C_2} \quad [\text{Nm/rad}]$$

$$\text{with } L_{pipe} = \frac{L_{ZR} - 2 \cdot L}{1000} \quad [\text{m}]$$

$C_1$  = torsion spring stiffness for spider see page 128

$C_2$  = from table on page 150 - 152

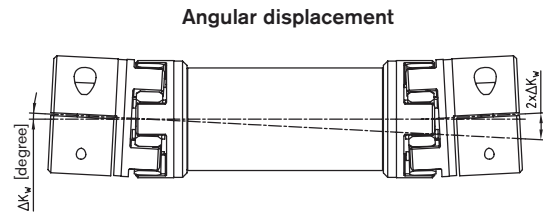
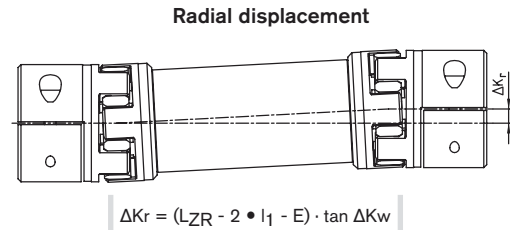
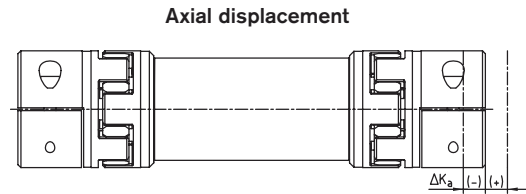

### Chart of critical bending speeds for type ZR3

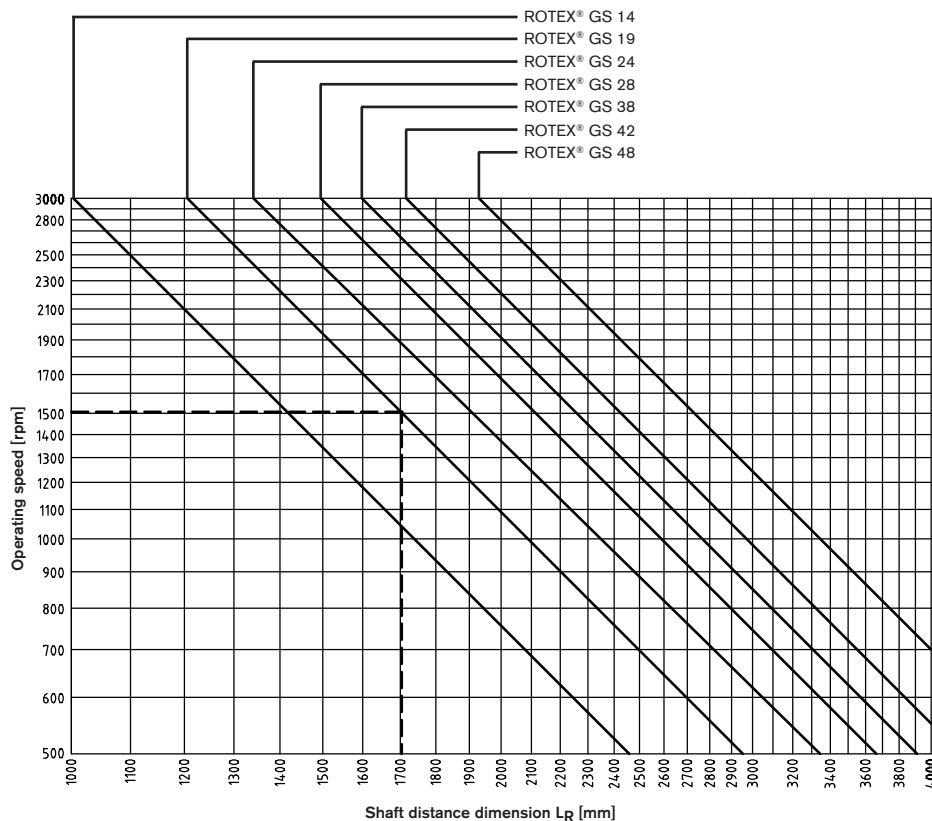

**Example:**  
 ROTEX® GS 19  
 Operating speed: 1500 rpm  
 Max. perm. shaft distance dimension: 1700 mm  
 Operating speed =  $n_{crit}/1.4$

# ROTEX® GS

## Backlash-free jaw couplings

### Types of hubs

Due to the numerous applications of ROTEX® GS for many different mounting situations, this coupling system is available with various hub types. The different hub types can be randomly combined within one size.



**Type 1.0**  
with feather keyway and setscrew  
Positive-locking power transmission, permissible torque depending on the permissible surface pressure. Not suitable for backlash-free power transmission with heavily reversing operation. (see page 128)



**Type 1.1**  
without feather keyway, with setscrew  
Non-positive torque transmission. Suitable for backlash-free transmission of very low torques. (For ATEX cat. 3 only) (see page 128)

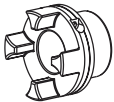

**Type 1.5**  
with hydraulic clamping system  
Integrated frictionally engaged shaft-hub-connection for transmitting high torques with easy assembly by means of a screw (see page 138).



**Type 2.0** clamping hub  
single slot without feather keyway  
Frictionally engaged, backlash-free shaft-hub-connection. Transmittable torques depending on bore diameter. Type 2.0 up to size 14 as standard. (For ATEX cat. 3 only) (see page 129)



**Type 2.1** clamping hub  
single slot with feather keyway  
Positive-locking power transmission with additional friction fit. The friction fit avoids resp. reduces reverse backlash. Surface pressure of the keyway connection is reduced. Type 2.1 up to size 14 as standard. (see page 129)



**Type 2.5** clamping hub  
double slotted, without feather keyway  
Frictionally engaged, backlash-free shaft-hub-connection. Transmittable torques depending on bore diameter. Type 2.5 from size 19 as standard. (For ATEX cat. 3 only) (see page 129)



**Type 2.6** clamping hub  
double slotted, with feather keyway  
Positive-locking power transmission with additional friction fit. The friction fit avoids resp. reduces reverse backlash. Surface pressure of the keyway connection is reduced. Type 2.6 from size 19 as standard. (see page 129)



**Type 2.8** compact type clamping hub C  
with axial slot, without feather keyway  
Frictionally engaged, backlash-free shaft-hub-connection, good properties of concentric running. Transmittable torques depending on bore diameter. Type 2.8 from size 24 as standard; size 7 - 19 type 2.8 single slotted. (For ATEX cat. 3 only) (see page 130)

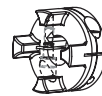

**Type 2.9** compact type clamping hub C  
with axial slot, with feather keyway  
Positive-locking power transmission with additional friction fit. Surface pressure of the keyway connection is reduced. Type 2.9 from size 24 as standard; size 7 - 19 type 2.9 single slotted. (see page 130)



**Type 6.0** clamping ring hub  
Integrated frictionally engaged shaft-hub-connection for the transmission of higher torques. Screwing on elastomer side. For details about torque and dimensions see page 132/133 and HP page 136. Suitable for high speeds. (see page 132)



**Type 6.0** precision clamping ring hub  
Operating principle equal to type 6.0, but highly accurate machining with slight modifications of design. (see page 134).



**Type 7.5** clamping hub type DH  
without feather keyway for double-cardanic connections  
Frictionally engaged, backlash-free shaft-hub-connection for radial assembly of coupling. Transmittable torques depending on bore diameter. For details of torque (see page 142).



**Type 7.6** clamping hub type DH  
with feather keyway for double-cardanic connections  
Positive-locking shaft-hub-connection with additional friction fit for radial assembly of coupling. The friction fit avoids resp. reduces reverse backlash. Surface pressure of the keyway connection is reduced. (see page 142)



**Type 7.8** clamping hub type H  
without feather keyway for single-cardanic connection  
Frictionally engaged shaft-hub-connection for radial assembly of coupling (see page 140)



**Type 7.9** clamping hub type H  
with feather keyway for single-cardanic connection  
Positive-locking shaft-hub-connection for radial assembly of coupling (see page 140)

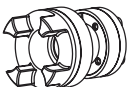

**Type 4.2** with CLAMPEX® KTR 250  
Frictionally engaged shaft-hub-connection to transmit high torques with clamping screws externally.



**Type 9.0** expansion hub  
Frictionally engaged connection for hollow shaft. Transmittable torques depend on bore diameter and hollow shaft. (see page 139)

### Special designs on request of customers

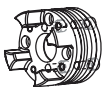

**Type 6.5** clamping ring hub  
Design equal to 6.0, but only clamping screws externally. For instance for radial disassembly of intermediate pipe (special design).

# ROTEX® GS

## Backlash-free jaw couplings

### Stock programme

		Finish bore [mm] according to ISO fit H7 / feather keyway with thread according to DIN 6885 sheet 1 - JS9																																
Size	Hub type	un/pilot bored	Ø2	Ø3	Ø4	Ø5	Ø6	Ø 6.35	Ø7	Ø8	Ø9	Ø9.5	Ø10	Ø11	Ø12	Ø14	Ø15	Ø16	Ø17	Ø18	Ø19	Ø20	Ø22	Ø24	Ø25	Ø28	Ø30	Ø32	Ø35	Ø38	Ø40	Ø42	Ø45	
7	1.1	●			●	●	●																											
	2.0	●		●	●	●	●	●																										
	2.8	●																																
8	2.8	●																																
	1.0	●																																
	1.1	●																																
9	2.0	●		●	●	●	●	●																										
	2.1	●																																
	2.8	●																																
12	1.0	●																																
	1.1	●																																
	2.0	●		●	●	●	●	●																										
13	2.1	●																																
	2.8	●																																
	1.0	●																																
14	1.1	●																																
	2.0	●		●	●	●	●	●																										
	2.1	●																																
16	2.8	●																																
	1.0	●																																
	2.5	●				■																												
19	2.6	●																																
	2.8	●																																
	2.9																																	
24	6.0 light																																	
	6.0 steel																																	
	6.0 P																																	
28	1.0	●																																
	2.5	●																																
	2.6	●																																
38	2.8	●																																
	2.9																																	
	6.0 light																																	
42	6.0 steel																																	
	6.0 P																																	
	6.0 P																																	
48	1.0	●																																
	2.5	●																																
	2.6	●																																
55	2.8	●																																
	2.9																																	
	6.0 light																																	
65	6.0 steel																																	
	6.0 P																																	
	6.0 P																																	
75	1.0	●																																
	2.5	●																																
	2.6	●																																
90	2.8	●																																
	2.9																																	
	6.0 light																																	
90	6.0 steel																																	
	6.0 P																																	
	6.0 P																																	

Taper bores for Fanuc motors:

GS 19 1:10 Ø11

GS 24 1:10 Ø16

<sup>1)</sup> Type 2.0/2.1

		Finish bores [mm]														
Size	Hub type	Ø28	Ø30	Ø32	Ø35	Ø38	Ø40	Ø42	Ø45	Ø48	Ø50	Ø55	Ø60	Ø65	Ø70	Ø80
42	6.0 light	●			●	●	●	●	●							
	6.0 steel	●	●	●	●	●	●	●	●	●	●	●				
48	6.0 steel			●	●	●	●	●	●	●	●	●				
55	6.0 steel					●	●	●	●	●	●	●	●			
65	6.0 steel						●	●	●	●	●	●	●	●		
75	6.0 steel							●	●	●	●	●	●	●	●	
90	6.0 steel										●	●	●	●	●	●

Bores on request

- = Pilot bored clamping hubs
- = Standard bore from stock
- Unbored hubs up to size 65 available from stock
- Other dimensions on request

# ROTEX® GS

## Backlash-free jaw couplings

### Standard types



For legend of pictogram refer to flapper on the cover



ROTEX® GS 5 - 38

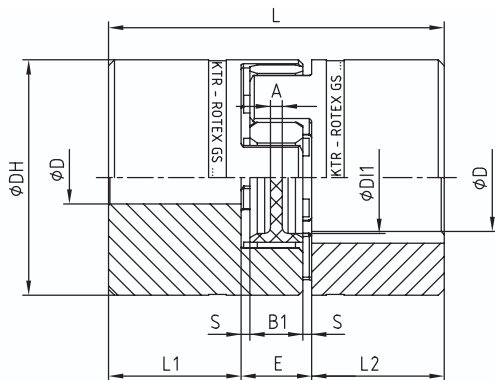

ROTEX® GS 42 - 90

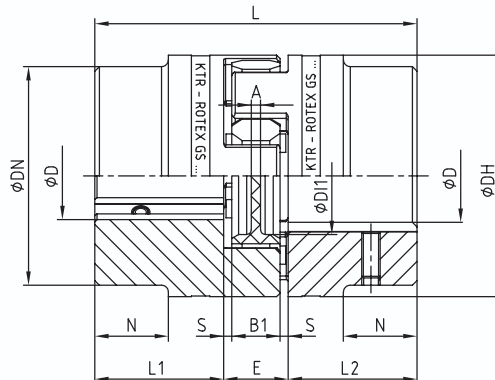

### Types of hubs:

Type 1.0

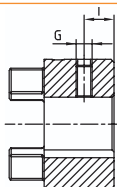

with feather keyway and setscrew

Type 1.1

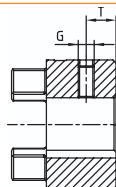

without feather keyway, with setscrew

Type 1.2

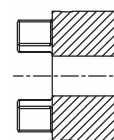

without feather keyway and without setscrew

### ROTEX® GS standard types - For size 5 to 38 hub material aluminium/for size 42 to 90 hub material steel

Size	Spider GS <sup>1)</sup> torque T <sub>KN</sub> [Nm]			D <sub>max.</sub> for hub type			Dimensions [mm]										Setscrew DIN EN ISO 4029		
	98 ShA	57 ShD	64 ShD	1.0	1.1	1.2	DN	DH	DI1	L	L1, L2	M, N	E	B1	S	A	G	T	TA [Nm]
5	0.9	-	-	-	6	6	-	10	-	15	5	-	5	4	0.5	4.0	M 2	2.5	0.35
7	2.0	-	2.4	7	7	7	-	14	-	22	7	-	8	6	1.0	6.0	M 3	3.5	0.6
9	5.0	-	6	10	11	11	-	20	7.2	30	10	-	10	8	1.0	1.5	M 4	5.0	1.5
12	9.0	-	12	12	12	12	-	25	8.5	34	11	-	12	10	1.0	3.5	M 4	5.0	1.5
14	12.5	-	16	16	16	16	-	30	10.5	35	11	-	13	10	1.5	2.0	M 4	5.0	1.5
19	21	23	26	24	-	-	-	40	18	66	25	-	16	12	2.0	3.0	M 5	10	2.0
24	60	68	75	32	-	-	-	55	27	78	30	-	18	14	2.0	3.0	M 5	10	2.0
28	160	180	200	38	-	-	-	65	30	90	35	-	20	15	2.5	4.0	M 8	15	10
38	325	365	405	45	-	-	-	80	38	114	45	-	24	18	3.0	4.0	M 8	15	10
42	450	495	560	55	-	-	85	95	46	126	50	28	26	20	3.0	4.0	M 8	20	10
48	525	590	655	62	-	-	95	105	51	140	56	32	28	21	3.5	4.0	M 8	20	10
55	685	770	825	74	-	-	110	120	60	160	65	37	30	22	4.0	4.5	M 10	20	17
65	940	1055	1175	80	-	-	115	135	68	185	75	47	35	26	4.5	4.5	M 10	20	17
75	1920	-	2400	95	-	-	135	160	80	210	85	53	40	30	5.0	5.0	M 10	25	17
90	3600	-	4500	110	-	-	160	200	104	245	100	62	45	34	5.5	6.5	M 12	30	40

<sup>1)</sup> For selections see page 22 et seqq./other spiders see page 127.

Ordering example:	ROTEX® GS 24	98 ShA-GS	Ø 20	2.5 - Ø24		1.0 - Ø20	
	Coupling size	Spider hardness	Optional: Bore in spider	Hub type	Finish bore	Hub type	Finish bore

**Types of hubs:**

Type 2.0  
Type 2.1

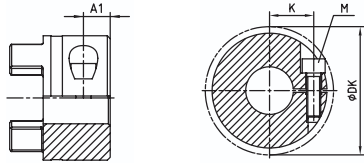

Size 5 to 14  
Type 2.0: single slotted clamping hub **without** feather keyway  
(only for ATEX cat. 3), torque depending on bore Ø  
Type 2.1: single slotted clamping hub **with** feather keyway

Type 2.5  
Type 2.6

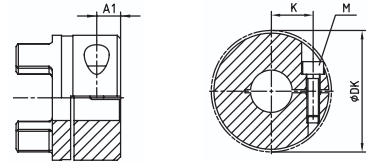

from size 19  
Type 2.5: double slotted clamping hub **without** feather keyway  
(only for ATEX cat. 3), torque depending on bore Ø  
Type 2.6: double slotted clamping hub **with** feather keyway

**ROTEX® GS standard types - For size 5 to 38 hub material aluminium/for size 42 to 90 hub material steel**

Size	Spider GS <sup>1)</sup> torque T <sub>KN</sub> [Nm] for 98 ShA			D <sub>max.</sub> for hub type				Dimensions [mm]											Clamping screws DIN EN ISO 4762 (ROTEX® GS 5 - DIN EN ISO 1207)				
	98 ShA	57 ShD	64 ShD	2.0	2.1	2.5	2.6	DN	DH	DI1	L	L1, L2	M, N	E	B1	S	A	M	A1	K	DK	T <sub>A</sub> [Nm]	
5	0.9	-	-	5	-	-	-	-	10	-	15	5	-	5	4	0.5	4.0	M1.2	2.5	3.5	11.4	- <sup>2)</sup>	
7	2	-	2.4	7	7	-	-	-	14	-	22	7	-	8	6	1.0	6.0	M 2	3.5	5.0	16.5	0.37	
9	5	-	6	11	11	-	-	-	20	7.2	30	10	-	10	8	1.0	1.5	M 2.5	5.0	7.5	23.4	0.76	
12	9	-	12	12	12	-	-	-	25	8.5	34	11	-	12	10	1.0	3.5	M 3	5.0	9.0	27.5	1.34	
14	12.5	-	16	16	16	-	-	-	30	10.5	35	11	-	13	10	1.5	2.0	M 3	5.0	11.5	32.2	1.34	
19	21	23	26	-	-	24	24	-	40	18	66	25	-	16	12	2.0	3.0	M 6	11.0	14.5	46	10	
24	60	68	75	-	-	28	28	-	55	27	78	30	-	18	14	2.0	3.0	M 6	10.5	20.0	57.5	10	
28	160	180	200	-	-	38	38	-	65	30	90	35	-	20	15	2.5	4.0	M 8	11.5	25.0	73	25	
38	325	365	405	-	-	45	45	-	80	38	114	45	-	24	18	3.0	4.0	M 8	15.5	30.0	83.5	25	
42	450	495	560	-	-	50	48	85	95	46	126	50	28	26	20	3.0	4.0	M 10	18	32.0	93.5	69	
48	525	590	655	-	-	55	55	95	105	51	140	56	32	28	21	3.5	4.0	M 12	21	36.0	105	120	
55	685	770	825	-	-	70	70 <sup>3)</sup>	110	120	60	160	65	37	30	22	4.0	4.5	M 12	26	42.5	119.5	120	
65	940	1055	1175	-	-	75	75 <sup>3)</sup>	115	135	68	185	75	47	35	26	4.5	4.5	M 12	33	45.0	124	120	
75	1920	-	2400	-	-	85	85	135	160	80	210	85	53	40	30	5.0	5.0	M 16	36	51.0	147.5	295	
90	3600	-	4500	-	-	90	90	160	200	104	245	100	62	45	34	5.5	6.5	M 20	40	60.0	176	580	

<sup>1)</sup> For selections see page 22 et seqq./other spiders see page 121.  
<sup>2)</sup> No T<sub>A</sub> defined (slotted screw)  
<sup>3)</sup> From Ø60 keyway opposite the clamping screw

**Review of shaft-hub-connection: Friction torques T<sub>R</sub> [Nm] for hub type 2.0**

Size	Ø3	Ø4	Ø5	Ø6	Ø7	Ø8	Ø9	Ø10	Ø11	Ø12	Ø13	Ø14	Ø15	Ø16
7	0.7	0.9	1.1	1.2	1.4									
9		1.6	1.9	2.2	2.6	2.9	3.2	3.5	3.8					
12		2.4	2.9	3.4	3.9	4.4	4.9	5.4	5.8	6.3				
14			3.1	3.6	4.2	4.7	5.2	5.7	6.2	6.7	7.1	7.6	8.0	8.5

**Review of shaft-hub-connection: Friction torques T<sub>R</sub> [Nm] for hub type 2.5**

Size	Ø8	Ø10	Ø11	Ø14	Ø15	Ø16	Ø18	Ø19	Ø20	Ø22	Ø24	Ø25	Ø28	Ø30	Ø32	Ø35	Ø38	Ø40	Ø42	Ø45	Ø48	Ø50	Ø55	Ø60	Ø65	Ø70	Ø75	Ø80	Ø85	Ø90	
19	19	23	25	31	33	35	39	41	42	46 <sup>4)</sup>	49 <sup>4)</sup>																				
24		24	26	33	35	37	41	43	45	48	52	54	59																		
28			63	67	71	79	82	86	94	101	105	115	122	129	139	148															
38				67	71	79	83	87	95	102	106	117	124	131	142	152	158	165	175												
42							188	197	214	231	240	264	281	297	320	343	358	373	395	417	431										
48											356	394	418	442	478	513	536	558	592	624	646	699									
55												456	493	529	553	577	611	646	668	724	778	830	882								
65															499	536	560	584	620	655	677	734	789	842	895	946					
75																			1107	1175	1242	1287	1396	1503	1607	1709	1810	1908	2005		
90																				1764	1876	1985	2057	2235	2409	2579	2746	2911	3072	3231	3387

<sup>4)</sup> Clamping hub single slotted with 2-off clamping screws M4 and dimension K = 15, T<sub>A</sub> = 2.9 Nm

# ROTEX® GS Compact Backlash-free jaw couplings

## Compact design



For legend of pictogram refer to flapper on the cover

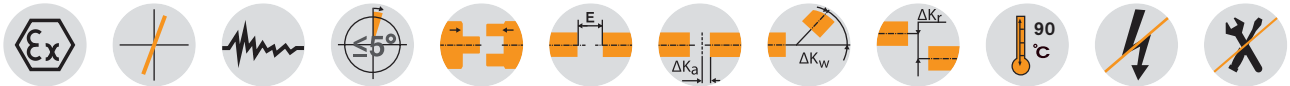

ROTEX® GS Compact - Hub material aluminium																	
Size	Spider GS <sup>1)</sup> torque T <sub>KN</sub> [Nm]				Dimensions [mm]									Clamping screws DIN EN ISO 4762			
	80 ShA	92 ShA	98 ShA	64 ShD	D <sub>max.</sub>	DH	DK	L	L1, L2	E	B1	S	DI1	A1	K	M	TA [Nm]
Single slotted hub type 2.8/2.9																	
7	0.7	1.2	2.0	2.4	7	14	16.6	18	5	8	6	1	-	2.5	5	M 2	0.37
8	0.5	-	2.0	2.4	8	15	17.3	20	7	6	5	0.5	6.2	4	5.4	M 2	0.52
9	1.8	3.0	5.0	6	9	20	21.3	24	7	10	8	1	-	3.5	6.7	M 2.5	0.76
12	3.0	5.0	9.0	12	12	25	26.2	26	7	12	10	1	-	3.5	8.3	M 3	1.34
13	3.6	-	11	14.5	12.7	25	25.7	26	8	10	8	1	10	4	8	M 3	1.9
14	4.0	7.5	12.5	16	16 <sup>2)</sup>	30	31.6	32	9.5	13	10	1.5	-	4.5	10	M 4	2.9
16	5.0	-	15	19	16	30	32.5	32	10.3	11.4	9.4	1	14	5.3	10.5	M 4	4.1
19	6.0	12.0	21.0	26.0	24 <sup>2)</sup>	40	45.5	50	17	16	12	2	-	9	14.0	M 6	10
Axially slotted hub type 2.8/2.9																	
24	-	35	60	75	32	55	57.5	54	18	18	14	2	-	11	20.0	M 6	10
28	-	95	160	200	35	65	69.0	62	21	20	15	2.5	-	12	23.8	M 8	25
38	-	190	325	405	45	80	86.0	76	26	24	18	3	-	15	29.5	M 10	49

Review of shaft-hub-connection: Friction torques T <sub>R</sub> [Nm] for hub type 2.8																										
Size	Ø3	Ø4	Ø5	Ø6	Ø7	Ø8	Ø9	Ø10	Ø11	Ø12	Ø14	Ø15	Ø16	Ø18	Ø19	Ø20	Ø24	Ø25	Ø28	Ø30	Ø32	Ø35	Ø38	Ø40	Ø42	Ø45
Single slotted hub type 2.8																										
7	0.7	0.9	1.1	1.2	1.4																					
8	1.0	1.2	1.5	1.8	2.0	2.3																				
9		1.5	1.8	2.1	2.4	2.7	3.0																			
12		2.3	2.8	3.3	3.8	4.3	4.7	5.2	5.6	6.0																
13		3.1	3.9	4.6	5.2	5.9	6.5	7.1	7.8	8.4																
14			5.0	5.9	6.8	7.7	8.5	9.4	10.2	11.0	7.2 <sup>2)</sup>	7.7 <sup>2)</sup>	8.1 <sup>2)</sup>													
16			7.2	8.5	9.8	11.0	12.2	13.4	14.6	15.7	17.9	19.0	20.0													
19						18.7	20.8	22.9	24.9	26.9	30.8	32.7	34.6	38.2	40.0	41.8	36.0 <sup>2)</sup>									
Axially slotted hub type 2.8																										
24								34	37	41	48	51	54	61	64	68	81	85	95	102	109					
28											87	93	100	112	118	124	149	156	174	187	199	218				
38												148	158	178	188	198	237	247	277	296	316	346	375	395	415	444

<sup>1)</sup> For selections see page 22 et seqq./other spiders see page 121.

<sup>2)</sup> Size 14 with screw M3 and dimension K = 10.4/DK = 30.5/T<sub>A</sub> = 1.34 Nm; size 19 with screw M5 and dimension K = 15.5/DK = 47mm/T<sub>A</sub> = 6 Nm

Ordering example:	ROTEX® GS 38	Compact	98 ShA-GS	Ø28	2.8 - Ø28		2.8 - Ø45	
	Coupling size	Type	Spider hardness	Optional: Bore in spider	Hub type	Finish bore	Hub type	Finish bore

ROTEX® GS 8, 13, 16  
Compact  
single slotted type 2.8

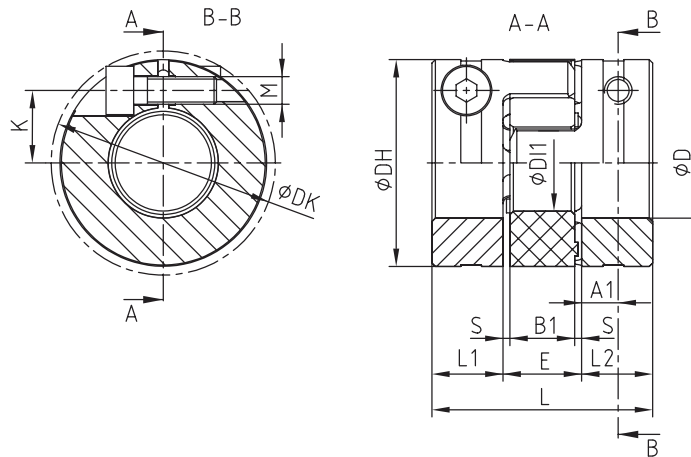

ROTEX® GS 7, 9, 12, 14, 19  
Compact  
single slotted type 2.8

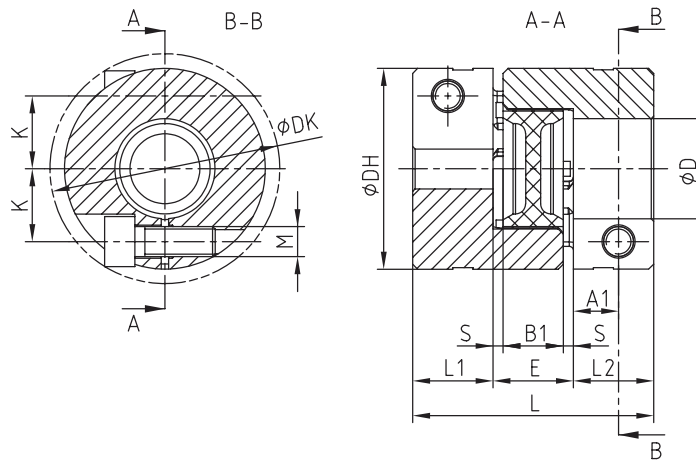

ROTEX® GS 24 - 38  
Compact  
axially slotted type 2.8

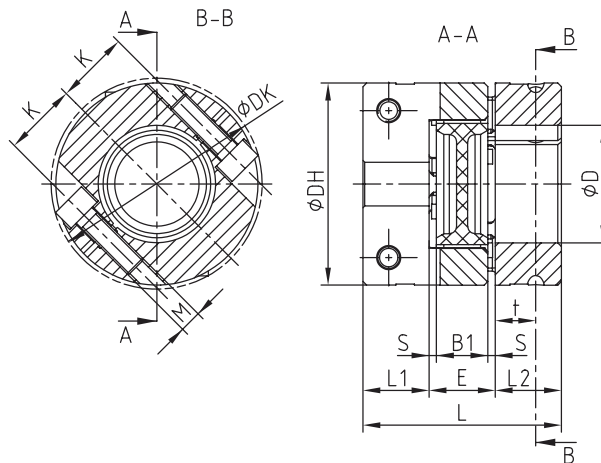

## Types of hubs

Type 2.8

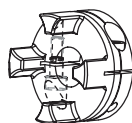

Compact type clamping hub C with axial slot, without feather keyway  
Type 2.8 from size 24 as standard, size 7 - 19 type 2.8 single slotted

Type 2.9

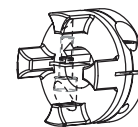

Compact type clamping hub C with axial slot, with feather keyway  
Type 2.9 from size 24 as standard, size 7 - 19 type 2.9 single slotted

# ROTEX® GS Clamping ring hubs light Backlash-free jaw couplings

Integrated clamping system made of aluminium

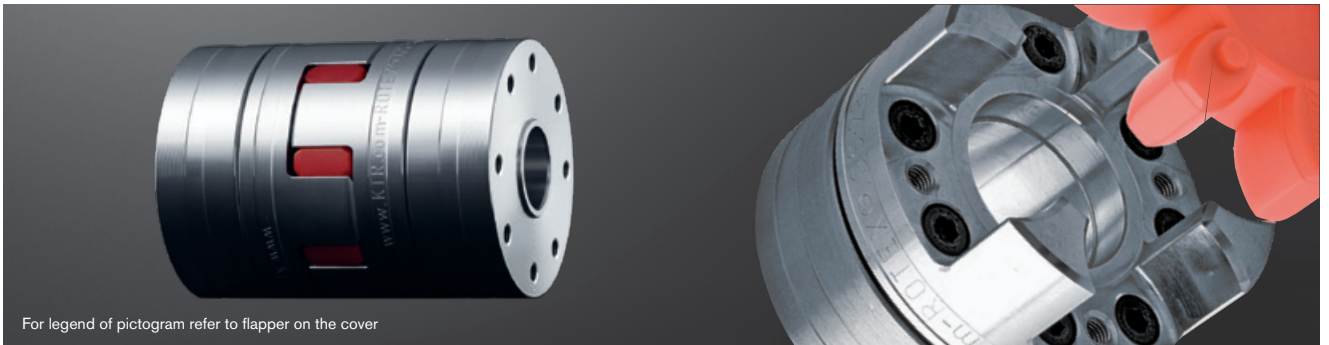

For legend of pictogram refer to flapper on the cover



Extraction thread M between clamping screws.

Clamping ring hub light with block mounting (hub and clamping ring mounted as a block)

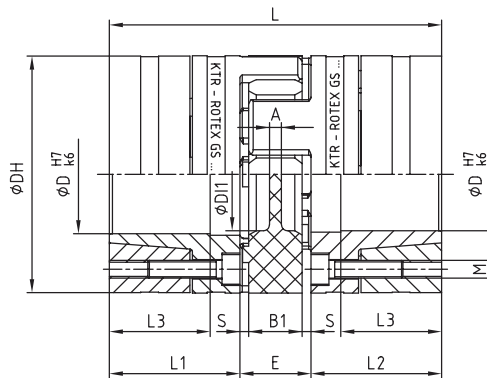

ROTEX® GS clamping ring hubs light																		
Size	Spider GS <sup>1)</sup> torque T <sub>KN</sub> [Nm]			Dimensions [mm]										Clamping screws DIN EN ISO 4762		Weight per hub with max. bore [kg]	Mass moment of inertia per hub with max. bore [kgm <sup>2</sup> ]	
	98 ShA	57 ShD	64 ShD	D <sub>max</sub>	DH <sup>2)</sup>	DI1	L	L1, L2	L3	E	B1	S	A	M	Z = number			T <sub>A</sub> [Nm]
13	11	-	14.5	13	25	10	34	12	9	10	8	1	-	M 2	6	0.37	0.014	1.39 x 10 <sup>-6</sup>
14	12.5	-	16.0	14	30	10.5	50	18.5	13.5	13	10	1.5	2.0	M 3	4	1.34	0.032	0.04 x 10 <sup>-4</sup>
19	21	23	26	20	40	18	66	25	18	16	12	2.0	3.0	M 4	6	3	0.077	0.19 x 10 <sup>-4</sup>
24	60	68	75	32	55	27	78	30	22	18	14	2.0	3.0	M 5	4	6	0.162	0.78 x 10 <sup>-4</sup>
28	160	180	200	38	65	30	90	35	27	20	15	2.5	4.0	M 5	8	6	0.240	1.70 x 10 <sup>-4</sup>
38	325	365	405	48	80	38	114	45	35	24	18	3.0	4.0	M 6	8	10	0.490	5.17 x 10 <sup>-4</sup>
42	450	495	560	51	95	46	126	50	35	26	20	3.0	4.0	M 8	4	25	0.772	11.17 x 10 <sup>-4</sup>
48	525	590	655	55	105	51	140	56	41	28	21	3.5	4.0	M 10	4	49	1.066	18.81 x 10 <sup>-4</sup>

<sup>1)</sup> For selections see page 22 et seqq./other spiders see page 121.

<sup>2)</sup> ØDH + 2 mm with high speeds for expansion of spider

Review of shaft-hub-connection: Friction torques T <sub>f</sub> [Nm] for hub type 6.0 light																											
Size		Ø3	Ø4	Ø5	Ø6	Ø8	Ø9	Ø10	Ø11	Ø14	Ø15	Ø16	Ø19	Ø20	Ø24	Ø25	Ø28	Ø30	Ø32	Ø35	Ø38	Ø40	Ø42	Ø45	Ø48	Ø50	Ø55*
13	H7/k6	1.3 <sup>3)</sup>	2.3 <sup>3)</sup>	4.3 <sup>3)</sup>	5.4 <sup>3)</sup>	10 <sup>3)</sup>	6.3	8.9	10.6																		
	H7/h6						2.4	4.8	5.4																		
14	H7/k6				8.2	13.1	18.7	20.5	25.9	36.2																	
	H7/h6				5.8	9.5	15.7	16.6	21.6	24.7																	
19	H7/k6							33	41	59	71	51	80	92													
	H7/h6							27	35	52	65	39	68	81													
24	H7/k6									84	99	93	139	157	160	177	232	177 <sup>4)</sup>									
	H7/h6									75	92	79	125	145	119	136	190	147 <sup>4)</sup>									
28	H7/k6											140	207	188	289	316	355	414	324	404	422						
	H7/h6											121	187	157	263	293	318	381	245	324	343						
38	H7/k6													290	439	480	567	656	617	759	733	825	922	808	937		
	H7/h6													247	403	447	530	626	499	636	606	696	792	678	809		
42	H7/k6																651	752	747	916	1001	1115	1044	1218	1404	1432	
	H7/h6																574	681	613	774	881	1001	888	1058	1241	1295	
48	H7/k6																765	822	927	1121	1220	1357	1318	1536	1768	1535	1823
	H7/h6																678	760	837	1047	1085	1231	1128	1339	1566	1331	1475

\* Standard bore tolerance H7, special tolerances on request \* From Ø55 tolerance G7/m6

The friction torque is reduced with bigger clearance. Steel or nodular iron with a yield strength of approx. 250 N/mm<sup>2</sup> or more can be used as shaft material. For strength calculation of shaft/hollow shaft see KTR standard 45510 on our homepage www.ktr.com.

<sup>3)</sup> Taper of hub with slot

<sup>4)</sup> Clamping ring hub with screws M4, Z = 8 and T<sub>A</sub> = 2.9 Nm

Ordering example:	ROTEX® GS 24	98 ShA-GS	Ø20	6.0 light - Ø24		6.0 light - Ø20	
	Coupling size	Spider hardness	Optional: Bore in spider	Hub type	Finish bore	Hub type	Finish bore

# ROTEX® GS Clamping ring hubs made of steel

## Backlash-free jaw couplings

### Integrated clamping system made of steel

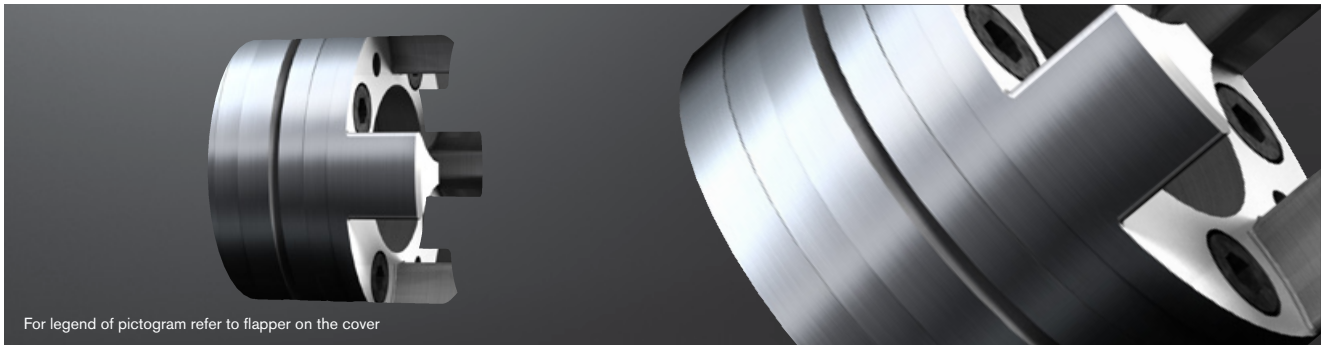

For legend of pictogram refer to flapper on the cover

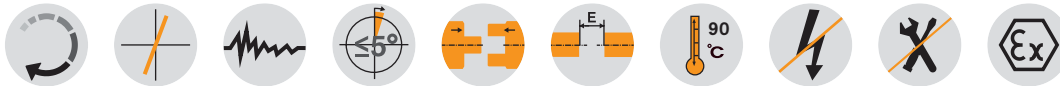

Extraction thread M between clamping screws.

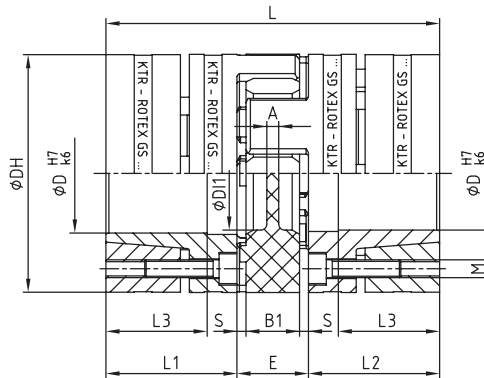

ROTEX® GS clamping ring hubs steel

Size	Spider GS <sup>1)</sup> torque I <sub>KN</sub> [Nm]			Dimensions [mm]										Clamping screws DIN EN ISO 4762			Weight per hub with max. bore [kg]	Mass moment of inertia per hub with max. bore [kgm <sup>2</sup> ]
	98 ShA	57 ShD	64 ShD	D <sub>max</sub>	DH <sup>2)</sup>	DI1	L	L1, L2	L3	E	B1	S	A	M	Z = number	T <sub>A</sub> [Nm]		
19	21	23	26	20	40	18	66	25	18	16	12	2.0	3.0	M 4	6	4.1	0.179	0.44 x 10 <sup>-4</sup>
24	60	68	75	28	55	27	78	30	22	18	14	2.0	3.0	M 5	4	8.5	0.399	1.91 x 10 <sup>-4</sup>
28	160	180	200	38	65	30	90	35	27	20	15	2.5	4.0	M 5	8	8.5	0.592	4.18 x 10 <sup>-4</sup>
38	325	365	405	48	80	38	114	45	35	24	18	3.0	4.0	M 6	8	14	1.225	12.9 x 10 <sup>-4</sup>
42	450	495	560	51	95	46	126	50	35	26	20	3.0	4.0	M 8	4	41	2.30	31.7 x 10 <sup>-4</sup>
48	525	590	655	55	105	51	140	56	41	28	21	3.5	4.0	M 10	4	69	3.08	52.0 x 10 <sup>-4</sup>
55	685	770	825	70	120	60	160	65	45	30	22	4.0	4.5	M 10	4	69	4.67	103.0 x 10 <sup>-4</sup>
65	940	1055	1175	70	135	68	185	75	55	35	26	4.5	4.5	M 12	4	120	6.70	191.0 x 10 <sup>-4</sup>
75	1920	-	2400	80	160	80	210	85	63	40	30	5.0	5.0	M 12	5	120	9.90	396.8 x 10 <sup>-4</sup>
90	3600	-	4500	105	200	104	245	100	75	45	34	5.5	6.5	M 16	5	295	17.7	1136 x 10 <sup>-4</sup>

<sup>1)</sup> For selections see page 22 et seq./other spiders see page 121.

<sup>2)</sup> ØDH + 2 mm with high speeds for expansion of spider

Review of shaft-hub-connection: Friction torques T<sub>f</sub> [Nm] for hub type 6.0 steel

Size		Ø10	Ø11	Ø14	Ø15	Ø16	Ø19	Ø20	Ø24	Ø25	Ø28	Ø30	Ø32	Ø35	Ø38	Ø40	Ø42	Ø45	Ø48	Ø50	Ø55*	Ø60*	Ø65*	Ø70*	Ø80*	Ø90*	Ø95*	Ø100*	Ø105*
19	H7/k6	27	32	69	84	57	94	110																					
	H7/h6	15	18	57	74	38	76	94																					
24	H7/k6			70	87	56	97	114	116	133	192																		
	H7/h6			55	74	32	72	93	84	103	173																		
28	H7/k6				108	131	207	148	253	285	315	382	330	433	503														
	H7/h6				74	97	172	94	207	242	267	343	260	377	453														
38	H7/k6							208	353	395	439	531	463	603	593	689	793	776											
	H7/h6							136	290	337	373	476	367	525	491	601	721	677											
42	H7/k6								445	495	595	526	677	671	775	718	872	1043	1061										
	H7/h6								387	429	540	429	600	569	687	599	773	970	978										
48	H7/k6									616	704	899	896	1030	962	1160	1379	1222	1543										
	H7/h6									513	590	806	775	924	822	1042	1290	1073	-										
55	H7/k6													863	856	991	918	1119	1110	1247	1277	1665	1605	2008					
	H7/h6													750	710	863	750	976	934	1089	-	-	-	-					
65	H7/k6															1446	1355	1637	1635	1827	1887	2429	2368	2930					
	H7/h6															1275	1135	1447	1404	1619	-	-	-	-					
75	H7/k6																1710	2053	2059	2294	2384	3040	2983	3664	4293				
	H7/h6																1460	1836	1797	2056	-	-	-	-					
90	H7/k6																			3845	4249	4795	5859	5906	7036	8047	9247	9575	10845
	H7/h6																			3445	-	-	-	-	-	-	-	-	-

\* From Ø55 tolerance G7/m6

The friction torque is reduced with bigger clearance. For the strength calculation of shaft/hollow shaft see KTR standard 45510 on our homepage www.ktr.com.

Ordering example:	ROTEX® GS 24	98 ShA-GS	Ø20	6.0 steel - Ø24		6.0 steel - Ø20	
	Coupling size	Spider hardness	Optional: Bore in spider	Hub type	Finish bore	Hub type	Finish bore

# ROTEX® GS P

## Backlash-free jaw couplings

Highly accurate type P according to DIN 69002



For legend of pictogram refer to flapper on the cover

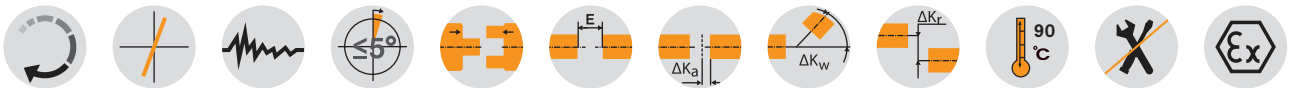

### ROTEX® GS P - hubs/clamping ring material steel

Size	Spider GS <sup>1)</sup> torque T <sub>KN</sub> [Nm]			Dimensions [mm]											Clamping screws DIN EN ISO 4762			Weight per hub with D <sub>Norm</sub> <sup>3)</sup> [kg]	Mass moment of inertia per hub with bore D <sub>Norm</sub> <sup>3)</sup> [kgm <sup>2</sup> ]
	98 ShA	57 ShD	64 ShD	D <sub>max</sub>	DH <sup>2)</sup>	DI1	L	L1, L2	L3	E	B1	S	A	DI2	M	Z = number	T <sub>A</sub> [Nm]		
14 P	12.5	-	16	15	32	10.5	50	18.5	15.5	13	10	1.5	2	-	M 3	4	1.89	0.08	0.011 x 10 <sup>-3</sup>
19 P	21	23	26	20	40	18	66	25	21	16	12	2	3	-	M 4	6	3.05	0.19	0.046 x 10 <sup>-3</sup>
24 P	60	68	75	28	55	27	78	30	25	18	14	2	3	-	M 5	4	8.5	0.44	0.201 x 10 <sup>-3</sup>
28 P	160	180	200	38	65	30	90	35	30	20	15	2.5	4	-	M 5	8	8.5	0.64	0.438 x 10 <sup>-3</sup>
38 P	325	365	405	48	80	38	114	45	40	24	18	3	4	-	M 6	8	14	1.32	1.325 x 10 <sup>-3</sup>
42 P	450	495	560	51	95	46	126	50	45	26	20	3	4	18.5	M 8	4	35	2.23	3.003 x 10 <sup>-3</sup>
48 P	525	590	655	55	105	51	140	56	50	28	21	3.5	4	20.5	M 10	4	69	3.09	5.043 x 10 <sup>-3</sup>
55 P	685	770	825	70	120	60	160	65	58	30	22	4	4.5	22.5	M 10	4	69	4.74	10.02 x 10 <sup>-3</sup>
65 P	940	1055	1175	70	135	68	185	75	55	35	26	4.5	4.5	30	M 12	4	120	6.70	191.0 x 10 <sup>-4</sup>
75 P	1920	-	2400	80	160	80	210	85	63	40	30	5.0	5.0	40	M 12	5	120	9.90	396.8 x 10 <sup>-4</sup>
90 P	3600	-	4500	105	200	104	245	100	75	45	34	5.5	6.5	50	M 16	5	295	17.7	1136 x 10 <sup>-4</sup>

<sup>1)</sup> For selections see page 22 et seqq./other spiders see page 121.

<sup>2)</sup> Ø DH + 2 mm with high speeds for expansion of spider

For the strength calculation of shaft/hollow shaft see KTR standard 45610 on our homepage www.ktr.com.

### Review of shaft-hub-connection: Friction torques T<sub>R</sub> [Nm] for hub type 6.0 steel

Size		Ø10	Ø11	Ø14	Ø15	Ø16	Ø19	Ø20	Ø24	Ø25	Ø28	Ø30	Ø32	Ø35	Ø38	Ø40	Ø42	Ø45	Ø48	Ø50	Ø55*	Ø60*	Ø65*	Ø70*	Ø80*	Ø90*	Ø95*	Ø100*	Ø105*		
14	H6/k6	11	13	29																											
	H6/h6	3	4	23																											
19	H6/k6	34	41	75	90	68	104	119																							
	H6/h6	22	26	64	80	49	85	103																							
24	H6/k6			79	95	70	110	126	134	149	201																				
	H6/h6			64	82	46	85	104	101	119	183																				
28	H6/k6				128	150	225	177	278	307	341	403	366	461	528																
	H6/h6				94	117	191	123	232	265	293	364	295	405	478																
38	H6/k6							247	386	426	475	560	511	641	644	733	828	825	970												
	H6/h6							174	323	368	408	505	415	564	542	645	757	726	897												
42	H6/k6								389	433	512	464	585	586	669	631	753	888	906												
	H6/h6									330	367	457	368	508	485	581	512	654	815	823											
48	H6/k6											672	762	945	957	1082	1033	1219	1423	1296	1606										
	H6/h6											568	647	852	836	977	892	1101	1334	1148											
55	H6/k6												920	929	1055	1002	1190	1198	1325	1388	1743	1722	2088								
	H6/h6												807	783	927	834	1047	1022	1168												
65	H6/k6															1532	1465	1731	1750	1931	2034	2534	2521	3038							
	H6/h6															1361	1245	1542	1520	1723											
75	H6/k6																	1835	2161	2190	2413	2551	3161	3158	3789	4421					
	H6/h6																	1585	1944	1928	2175										
90	H6/k6																			4046	4503	5057	6079	6181	7324	8398	9530	9892	11084		
	H6/h6																			3645											

\* From Ø55 tolerance G6/m6.

The friction torque is reduced with bigger clearance. For the strength calculation of shaft/hollow shaft see KTR standard 45610 on our homepage www.ktr.com.

### Assignment for stub spindles according to DIN 69002

Spindle drive	ROTEX® GS P size	Dimensions according to DIN 69002											Transmittable torque T <sub>R</sub> with D [Nm] <sup>3)</sup>	Weight per hub with bore D <sub>standard</sub> <sup>3)</sup> [kg]	Mass moment of inertia with bore D <sub>standard</sub> <sup>3)</sup> [kgm <sup>2</sup> ]
		Standard spindle shaft diameter D	DN4	D5	DI2	DH	L1, L2	L	E						
25 x 20	14 P	14	17	17	8.5	32	18.5	50	13	25	0.08	0.011 x 10 <sup>-3</sup>			
32k x 25	19 P37.5	16	20	19	9.5	37.5	25	66	16	60	0.16	0.037 x 10 <sup>-3</sup>			
32g x 30	19 P	19	23	22	9.5	40	25	66	16	71	0.19	0.046 x 10 <sup>-3</sup>			
40 x 35	24 P50	24	28	29	12.5	50	30	78	18	108	0.331	0.136 x 10 <sup>-3</sup>			
50 x 45	24 P	25	30	30	12.5	55	30	78	18	170	0.44	0.201 x 10 <sup>-3</sup>			
63 x 55	28 P	35	40	40	14.5	65	35	90	20	506	0.64	0.438 x 10 <sup>-3</sup>			
80 x 75	38 P	40	46	46	16.5	80	45	114	24	821	1.32	1.325 x 10 <sup>-3</sup>			

<sup>3)</sup> Standard spindle shaft diameter

Ordering example:	ROTEX® GS 24 P	98 ShA-GS	6.0 - Ø25				6.0 - Ø25	
	Coupling size	Spider hardness	Hub type	Finish bore	Hub type	Finish bore		

Components

Extraction thread M between clamping screws.

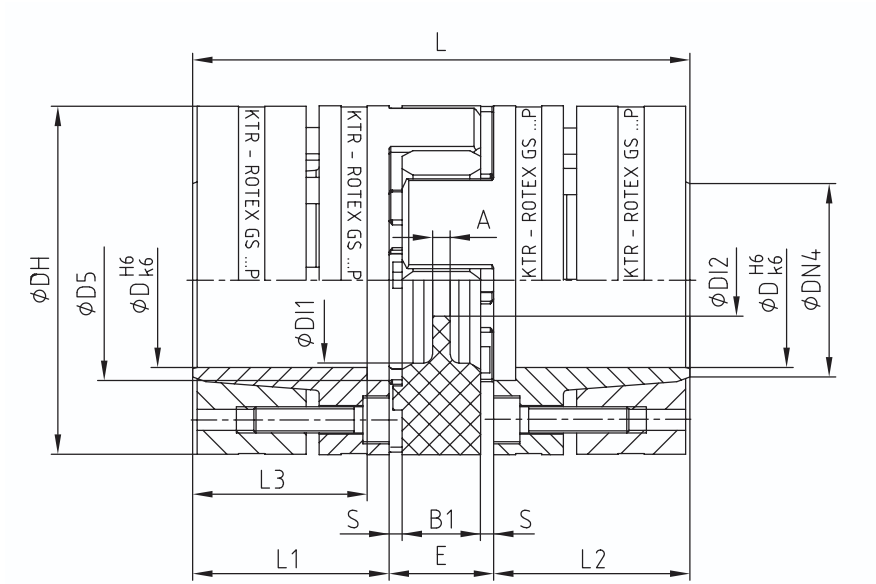

ROTEX® GS P with central coolant supply for stub spindles and multiple spindle heads

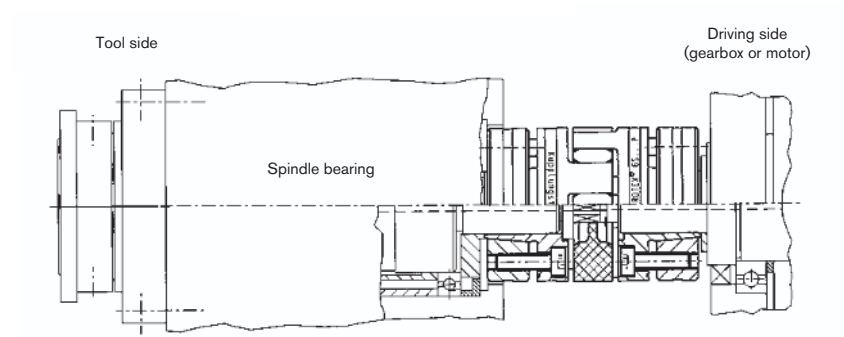

# ROTEX® GS HP

## Backlash-free shaft coupling

### Highly accurate closed coupling system

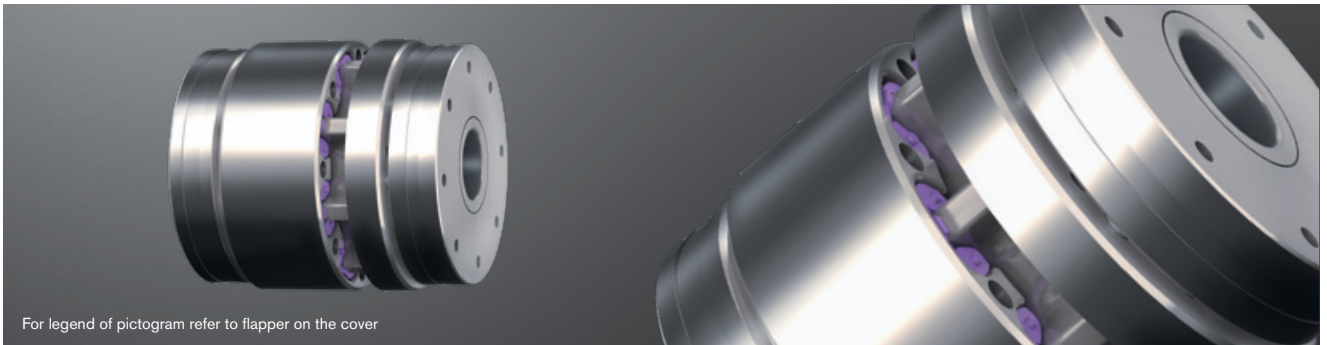

For legend of pictogram refer to flapper on the cover

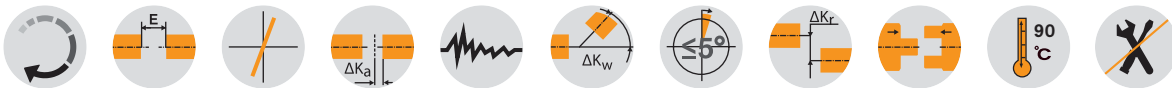

#### ROTEX® GS HP - clamping ring hubs/clamping ring material steel

Size	Tooth element ROTEX® GS HP <sup>1)</sup> torque T <sub>KN</sub> [Nm]		max. speed <sup>2)</sup> [rpm]	Dimensions [mm]												Clamping screws DIN EN ISO 4762		Weight of coupling with max. bore [kg]	Mass moment of inertia of coupling with max. bore [kgm <sup>2</sup> ]
	52 ShD	65 ShD		max. D1, D2	DH1	DH	L	L1, L2	L3	L31	N	E	B1	S	M	Z = number	TA [Nm]		
24	100	125	59,000	25	55	48	73	24.5	17.5	17.5	15	24	20	2	5	5	7.7	0.74	0.000317
28	160	200	47,000	35	66	58	78	27	19	19	17	24	20	2	5	6	7.7	1.02	0.000653
38	400	500	39,000	45	80	76	82	29	26	21	18	24	20	2	5	8	7.7	1.54	0.001534
42	475	590	35,000	51	95	82	99	36	30	27	24	27	22	3	6	8	13	2.59	0.003441
48	550	685	30,000	55	105	92	101	37	30	30	25	27	22	3	6	9	13	3.39	0.005481
55	725	905	26,000	60	120	105	103	38	31	31	26	27	22	3	6	10	13	6.84	0.009172
65	1075	1340	22,500	70	139	125	107	40	39	36	25.3	27	22	3	6	12	14	7.00	0.019633

<sup>1)</sup> For selections see page 22 et seqq./other spiders see page 121.

<sup>2)</sup> Speeds must be empirically determined. Not generally transferable to every application.

#### Review of shaft-hub-connection: Friction torques T<sub>f</sub> [Nm] for hub type 6.0 steel

Size		Ø12	Ø15	Ø18	Ø19	Ø20	Ø22	Ø24	Ø25	Ø28	Ø32	Ø35	Ø38	Ø40	Ø42	Ø45	Ø48	Ø50	Ø55 *	Ø60 *	Ø65 *	
24	H6/k6	55	102	165	115	133	172	217	241													
	H6/h6	34	82	150	81	100	143	194	222													
28	H6/k6		125	199	226	158	202	253	280	246	340	432										
	H6/h6		99	177	201	111	157	211	240	195	292	398										
38	H6/k6					216	274	340	376	374	508	635	586	666	752	649						
	H6/h6					170	231	301	339	318	452	592	509	589	674	524						
42	H6/k6										665	830	1015	770	871	1035	1215	1153				
	H6/h6										570	749	953	656	766	948	1150	1076				
48	H6/k6														1128	1321	1530	1211	1477			
	H6/h6														914	1102	1306	985	-			
55	H6/k6														1314	1543	1562	1711	1562	1915		
	H6/h6														1217	1463	1329	1474	-	-		
65	H6/k6															1606	1852	2026	1891	2306	2134	
	H6/h6															1349	1584	1751	-	-	-	-

\* From Ø55 G6/m6.

The friction torque depends on the speed.

The friction torque is reduced with bigger clearance. For the strength calculation of shaft/hollow shaft see KTR standard 45710 on our homepage www.ktr.com.

#### Technical data

Size	Tooth element ROTEX® GS HP	Displacements			Torsional stiffness [Nm/rad]		Radial spring stiffness [N/mm]	Axial stiffness [N/mm]
		Axial ΔK <sub>a</sub> [mm]	Radial ΔK <sub>r</sub> [mm]	Angular ΔK <sub>w</sub> [degree]	CT stat.	CT dyn.	C <sub>r</sub>	C <sub>a</sub>
24	52 ShD	+1.0/-0.8	0.10	0.9	3,780	10,950	7,210	3,440
	64 ShD		0.07	0.8	6,050	17,520	10,100	4,820
28	52 ShD	+1.0/-0.8	0.10	0.9	7,760	23,980	8,380	4,360
	64 ShD		0.07	0.8	12,420	38,370	11,740	6,110
38	52 ShD	+1.0/-0.8	0.10	0.9	27,800	69,000	11,190	6,280
	64 ShD		0.07	0.8	44,480	110,400	15,670	8,790
42	52 ShD	+1.4/-1.0	0.14	0.9	52,950	101,750	12,490	7,410
	64 ShD		0.10	0.8	84,720	162,800	17,490	10,380
48	52 ShD	+1.4/-1.0	0.14	0.9	64,140	128,530	11,480	8,230
	64 ShD		0.10	0.8	102,620	205,640	16,070	11,520
55	52 ShD	+1.4/-1.0	0.14	0.9	87,500	198,940	12,240	9,830
	64 ShD		0.10	0.8	140,000	318,300	17,140	13,770
65	52 ShD	+1.4/-1.0	0.14	0.9	110,350	295,200	14,000	14,820
	64 ShD		0.10	0.8	174,930	472,300	19,600	20,750

The displacement figures may only be used one by one, if they appear simultaneously, they must be limited in proportion. Care should be taken to maintain the distance dimension E accurately in order to allow for axial clearance of the coupling while in operation. Detailed mounting instructions are shown on our homepage www.ktr.com.

Ordering example:

ROTEX® GS 24 HP	98 ShA-GS	d1 6.0 - Ø25		d2 6.0 - Ø25	
Coupling size	Hardness of tooth element	Hub type	Finish bore	Hub type	Finish bore

Components

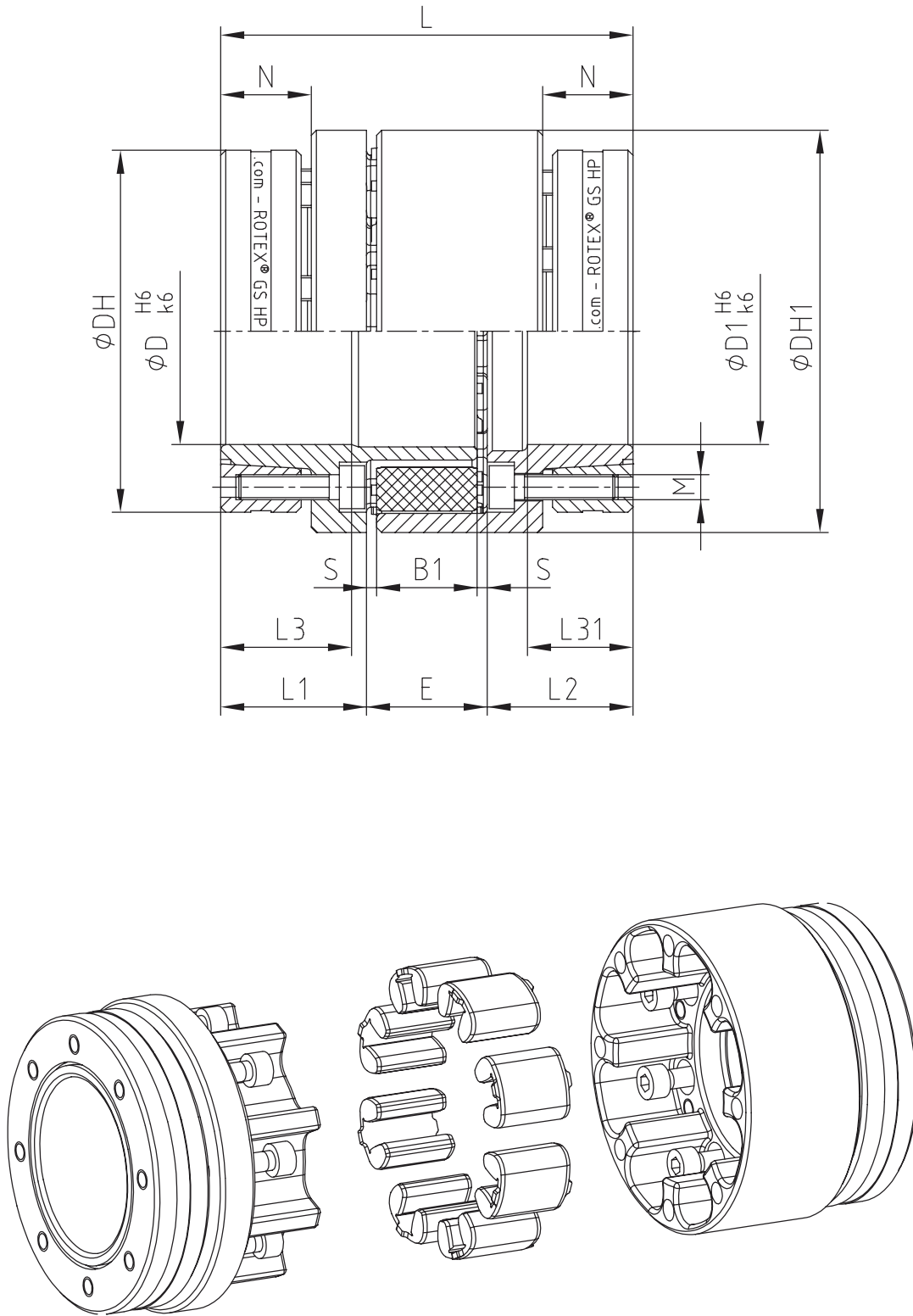

ROTEX® GS

ROTEX® GS HP

Backlash-free  
servo couplings

TOOLFLEX®

RADEX®-NC

# ROTEX® GS P ETP®

## Backlash-free jaw couplings

### Integrated hydraulic clamping system

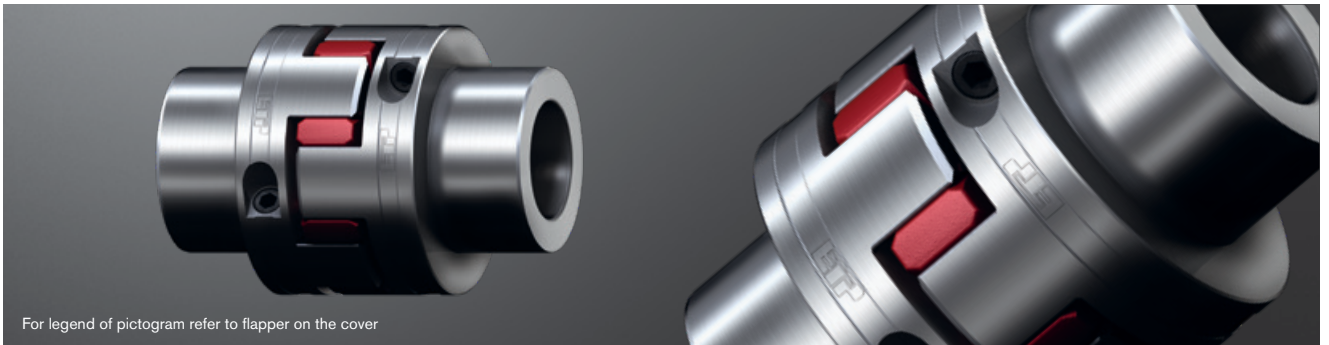

For legend of pictogram refer to flapper on the cover

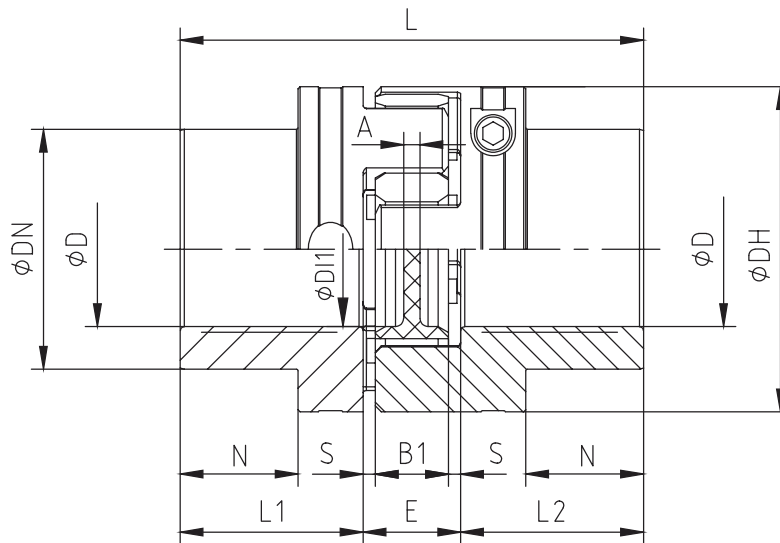
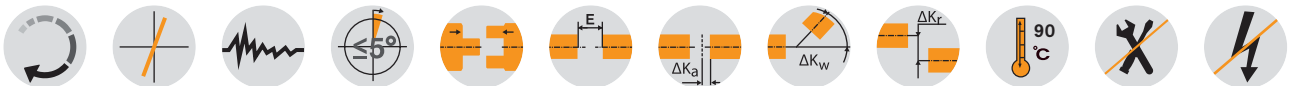

ROTEX® GS P ETP®																
Size	Spider GS <sup>1)</sup> torque T <sub>KN</sub> [Nm]			Dimensions [mm]										Setscrew		Weight per hub with max. bore [kg]
	98 ShA	57 ShA	64 ShD	D <sub>max</sub>	DH <sup>2)</sup>	DI1	L	L1, L2	N	E	B1	S	A	M	T <sub>A</sub> [Nm]	
24	60	68	75	24	55	27	78	30	16	18	14	2	3	M 6	5	0.33
28	160	180	200	32	65	30	90	35	20	20	15	2.5	4	M 6	5	0.53
38	325	365	405	40	80	38	114	45	29	24	18	3	4	M 6	5	0.98
42	450	495	560	48	95	46	126	50	34	26	20	3.5	4	M 6	5	1.51

<sup>1)</sup> For selections see page 22 et seqq./other spiders see page 121.

<sup>2)</sup> ØDH + 2 mm with high speeds for expansion of spider

Review of shaft-hub-connection: Friction torques T <sub>R</sub> [Nm] for hub type ROTEX® GS P ETP®																	
Size	Tolerance fit	Bore diameter D/collar diameter DN															
		Ø15/ Ø24	Ø16/ Ø26	Ø19/ Ø30	Ø20/ Ø32	Ø24/ Ø39	Ø25/ Ø40	Ø28/ Ø44	Ø30/ Ø47	Ø32/ Ø50	Ø35/ Ø55	Ø38/ Ø59	Ø40/ Ø62	Ø42/ Ø65	Ø45/ Ø70	Ø48/ Ø74	
24	F6/h6	42	50	70	80	125											
28		50	60	80	95	150	160	210	230	250							
38						220	230	310	350	380	450	570	610				
42							270	360	410	440	540	660	730	820	940	1100	

ETP® is a registered trademark by ETP® Transmission AB.

Ordering example:	ROTEX® GS P ETP® 24	98 ShA-GS	Ø20	Ø24	Ø20
	Coupling size	Spider hardness	Optional: Bore in spider	Finish bore	Finish bore

# ROTEX® GS expansion hubs

## Backlash-free jaw couplings

### Clamping system for hollow shaft connection

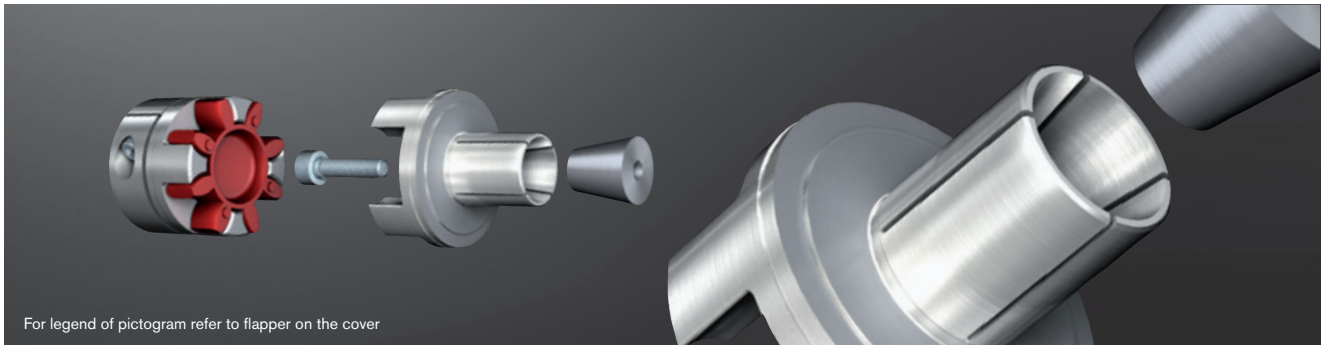

For legend of pictogram refer to flapper on the cover

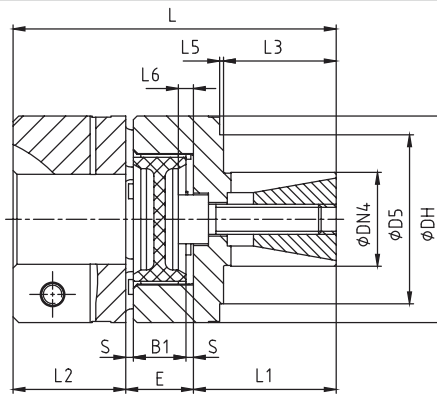
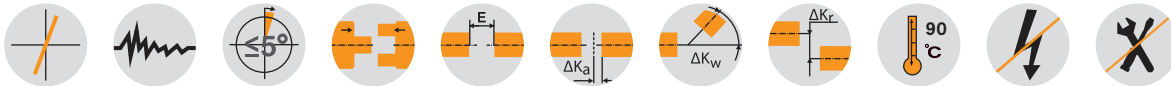

ROTEX® GS expansion hub - Expansion hub material aluminium/clamp pin material stainless steel																	
Size	Spider GS <sup>2)</sup> torque T <sub>KN</sub> [Nm]				Dimensions [mm]											Friction torque <sup>3)</sup> [Nm]	
	80 ShA	98 ShA	57 ShA	64 ShD	DN4 <sup>2)</sup>	D5	DH	L1 <sup>2)</sup>	L2	L3 <sup>2)</sup>	L5 <sup>2)</sup>	L6	L	E	B1		S
9	1.8	5	-	6	10	-	20	20	10	11	-	0	40	10	8	1.0	6.4
12	3	9	-	12	10	20	25	19	11	14	1.5	2	42	12	10	1.0	7.7
14	4	12.5	-	16	12	24	30	18.5	11	12.5	3	2	42.5	13	10	1.5	7.7
19	6	21	23	26	20	35	40	28	25	20	1	0	69	16	12	2.0	35.7
24	-	60	68	75	25	45	55	38	30	30	1	4	86	18	14	2.0	82.0
28	-	160	180	200	35	55	65	44	35	36	1	5	99	20	15	2.5	182.0

<sup>1)</sup> For selections see page 22 et seq./other spiders see page 121.

<sup>2)</sup> Example: Other dimensions on customers' request.

<sup>3)</sup> The friction torque applies for the specified figures DN4, L1, L3, L5 and a hollow shaft material steel.

### ROTEX® GS expansion hub for axis of belt

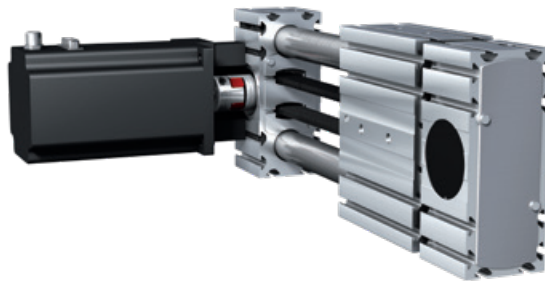

### Special types for hollow shaft connections

Shaft journal

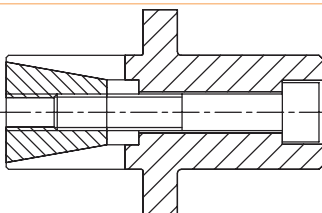

ROTEX® GS hub with CLAMPEX® KTR 150

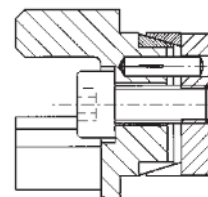

Ordering example:	ROTEX® GS 24	98 ShA-GS	Ø20	9.0 - Ø24		2.5 - Ø20	
	Coupling size	Spider hardness	Optional: Bore in spider	Hub type	Finish bore	Hub type	Finish bore

# ROTEX® GS A-H

## Backlash-free jaw couplings

### Drop-out center design coupling

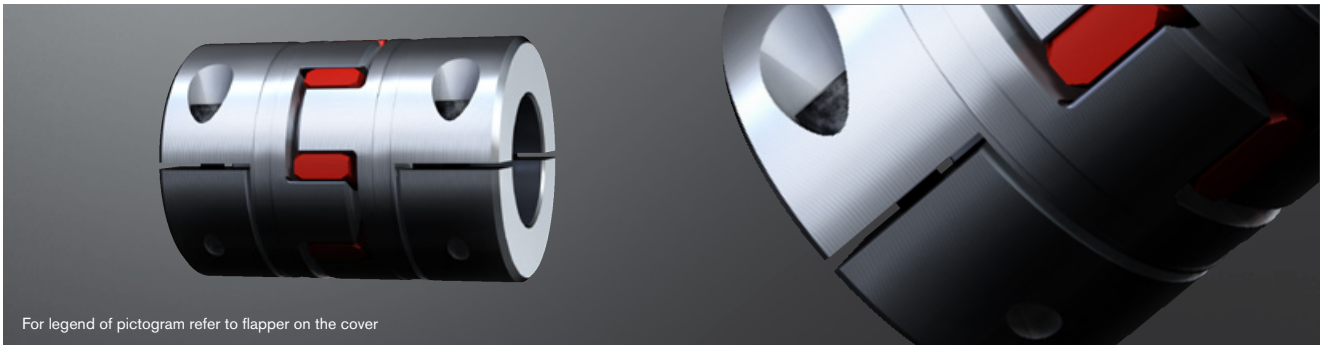

For legend of pictogram refer to flapper on the cover

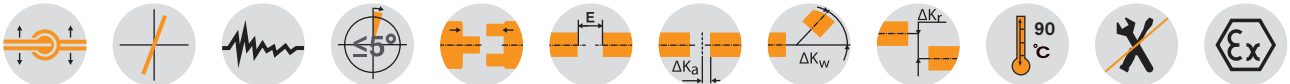

#### ROTEX® GS type A-H - Hub material aluminium

Size	Dimensions [mm]											Cap screws DIN EN ISO 4762	
	D <sub>max</sub>	L	L1, L2	E	B1	S	DH	DK	X1, X2	DBSE	M	T <sub>A</sub> [Nm]	
19	20	66	25	16	12	2.0	40	46	17.5	31	M 6	10	
24	30	78	30	18	14	2.0	55	57.5	22.0	34	M 6	10	
28	38	90	35	20	15	2.5	65	73	25.0	40	M 8	25	
38	45	114	45	24	18	3.0	80	83.5	33.0	48	M 8	25	
42	50	126	50	26	20	3.0	95	93.5	36.5	53	M 10	49	

#### Technical data

Size	Spider Shore-GS <sup>1)</sup>	Shore scale	Max. speed [rpm]	Torque [Nm]		Static torsion spring stiffness [Nm/rad]	Weight per hub with max. bore [kg]	Mass moment of inertia J per hub with max. bore [kgm <sup>2</sup> ]
				T <sub>KN</sub>	T <sub>K max</sub>			
19	80	A	9550	6.0	12.0	618	77 x 10 <sup>-3</sup>	19.6 x 10 <sup>-6</sup>
	92	A		12.0	24.0	1090		
	98	A		21.0	42.0	1512		
	64	D		26.0	52.0	2560		
24	92	A	6950	35	70	2280	161 x 10 <sup>-3</sup>	77.3 x 10 <sup>-6</sup>
	98	A		60	120	3640		
	64	D		75	150	5030		
28	92	A	5850	95	190	4080	240 x 10 <sup>-3</sup>	173 x 10 <sup>-6</sup>
	98	A		160	320	6410		
	64	D		200	400	10260		
38	92	A	4750	190	380	6525	470 x 10 <sup>-3</sup>	496 x 10 <sup>-6</sup>
	98	A		325	650	11800		
	64	D		405	810	26300		
42	92	A	4000	265	530	10870	1770 x 10 <sup>-3</sup>	2409 x 10 <sup>-6</sup>
	98	A		450	900	21594		
	64	D		560	1120	36860		

<sup>1)</sup> For selections see page 22 et seqq./other spiders see page 121.

<sup>2)</sup> Static torsion spring stiffness with 0.5 x T<sub>KN</sub>

To make sure that the coupling can be assembled/disassembled radially, please observe the insertion dimension X1/X2 of the shafts.

#### Review of shaft-hub-connection: Friction torques T<sub>R</sub> [Nm] for hub type 7.8

Size	Ø8	Ø10	Ø11	Ø14	Ø15	Ø16	Ø18	Ø19	Ø20	Ø22	Ø24	Ø25	Ø28	Ø30	Ø32	Ø35	Ø38	Ø40	Ø42	Ø45	Ø46	Ø48	Ø50
19	17	21	23	30	32	34	38	40	42														
24		21	23	30	32	34	38	40	42	47	51	53	59	63									
28				54	58	62	70	74	78	86	93	97	109	117	124	136	148						
38							70	74	78	86	93	97	109	117	124	136	148	156	163	175			
42										136	149	155	174	186	198	217	235	248	260	279	285	297	310

Ordering example:

ROTEX® GS 38	A-H	98 ShA-GS	7.8 – Ø38		7.9 – Ø30	
Coupling size	Type	Spider hardness	Hub type	Finish bore	Hub type	Finish bore

Type A-H

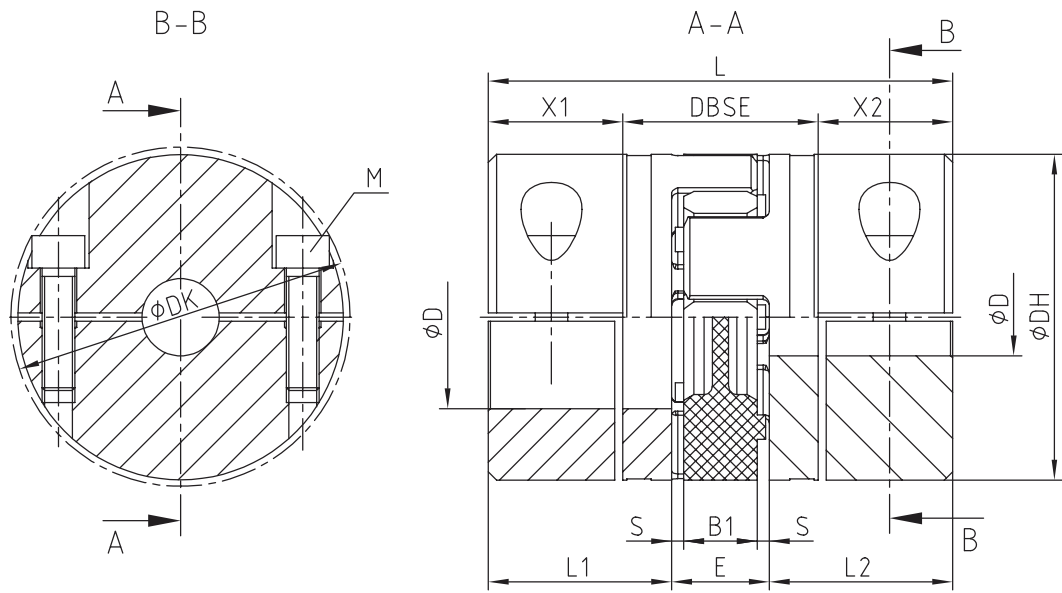

Caution:  
Feather keyways are offset to one another by approx. 5°!  
Hub material: Al-H

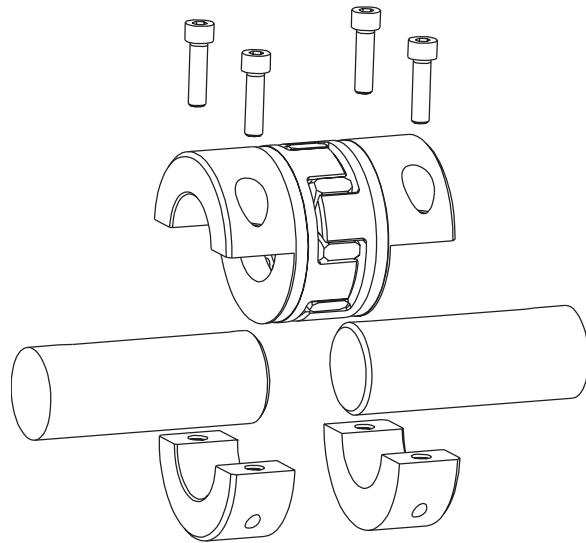

Types of hubs

Type 7.8

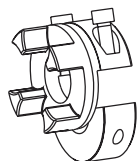

clamping hub type H without feather keyway for single-cardanic connection

Type 7.9

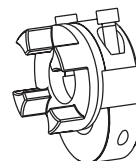

clamping hub type H with feather keyway for single-cardanic connection

# ROTEX® GS DKM

## Backlash-free jaw couplings

### Double-cardanic jaw coupling

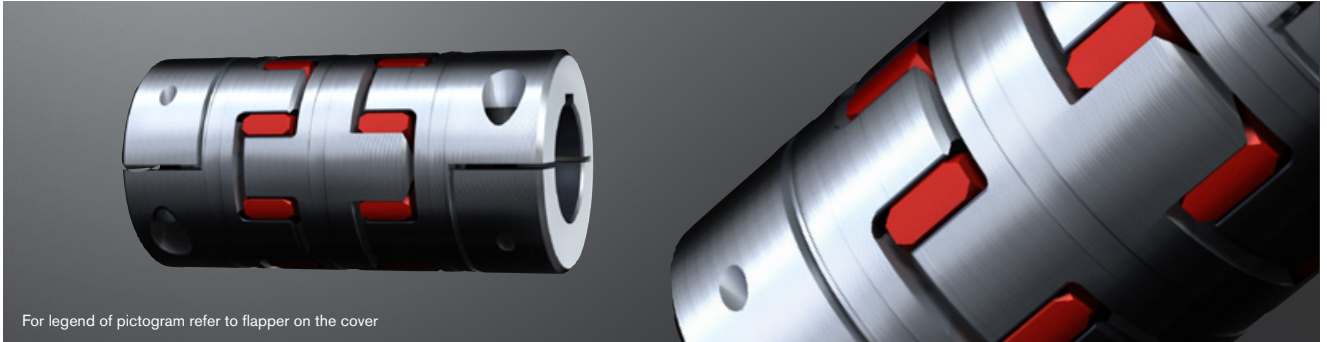

For legend of pictogram refer to flapper on the cover

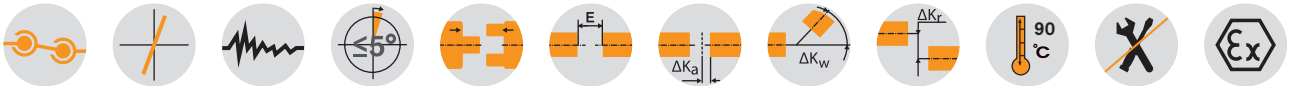

ROTEX® GS DKM - Spacer material aluminium/hub material depends on hub type

Size	Spider GS <sup>1)</sup> torque T <sub>KN</sub> [Nm]		Dimensions [mm]													
	98 ShA	64 ShD	D <sub>max</sub> <sup>2)</sup>	DN	DH	DI1	DI	L1, L2	N	L11	DBSE	L	E	B1	S	A
5	0.9	—	5	—	10	—	—	5	—	3	13	23	5	4	0.5	4.0
7	2.0	2.4	7	—	14	—	—	7	—	4	20	34	8	6	1.0	6.0
9	5.0	6.0	11	—	20	7.2	—	10	—	5	25	45	10	8	1.0	1.5
12	9.0	12.0	12	—	25	8.5	—	11	—	6	30	52	12	10	1.0	3.5
14	12.5	16.0	16	—	30	10.5	—	11	—	8	34	56	13	10	1.5	2.0
19	21.0	26.0	24	—	40	18.0	18	25	—	10	42	92	16	12	2.0	3.0
24	60	75	30	—	55	27.0	27	30	—	16	52	112	18	14	2.0	3.0
28	160	200	38	—	65	30.0	30	35	—	18	58	128	20	15	2.5	4.0
38	325	405	45	—	80	38.0	38	45	—	20	68	158	24	18	3.0	4.0
42	450	560	55	85	95	46	46	50	28	22	74	174	26	20	3.0	4.0
48	525	655	62	95	105	51	51	56	32	24	80	192	28	21	3.5	4.0
55	685	825	74	110	120	60	60	65	37	28	88	218	30	22	4.0	4.5

<sup>1)</sup> For selections see page 22 et seqq./other spiders see page 121.

<sup>2)</sup> Dependent on hub type. Hub types can be freely selected, for summary see page 126.

Ordering  
example:

ROTEX® GS 24	DKM	98 ShA-GS	Ø25	1.0 - Ø25	2.5 - Ø25		
Coupling size	Type	Spider hardness	Optional: Bore in spider	Hub type	Finish bore	Hub type	Finish bore

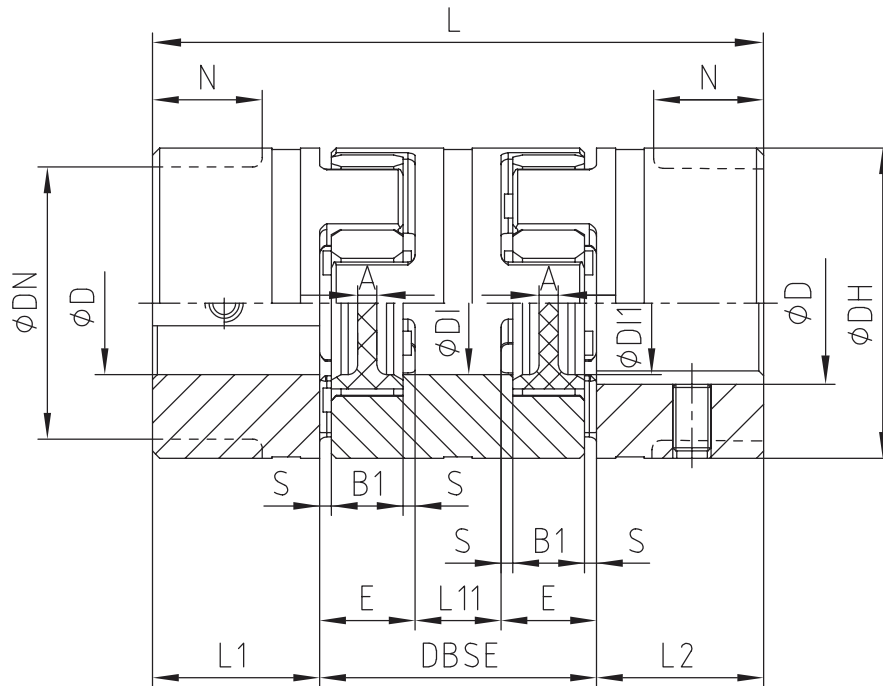

Other types:

ROTEX® GS - CF - DKM

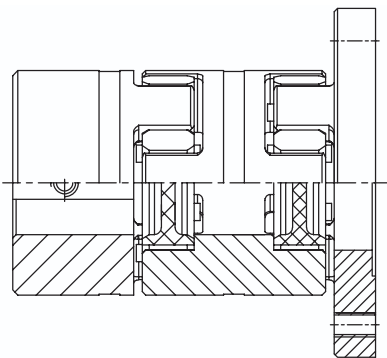

ROTEX® GS DKM-H

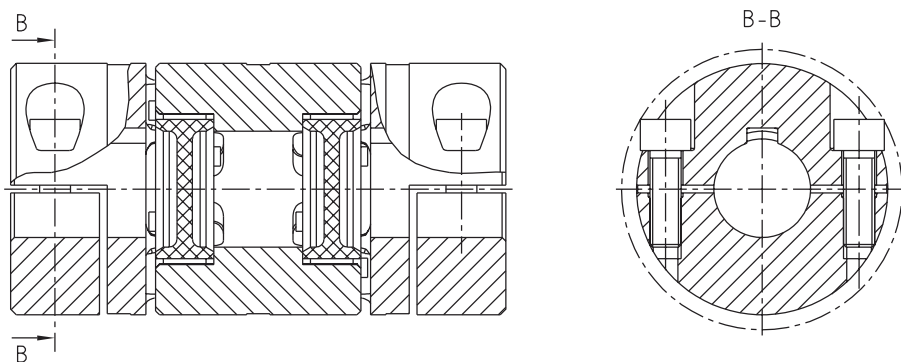

# ROTEX® GS ZR3

## Backlash-free intermediate shaft couplings

### Intermediate shaft coupling with aluminium pipe

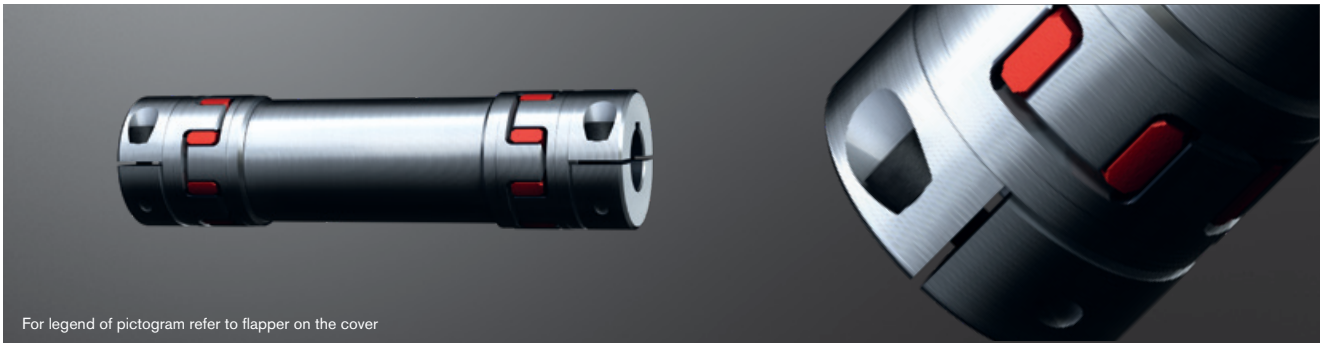

For legend of pictogram refer to flapper on the cover



#### Type ZR3

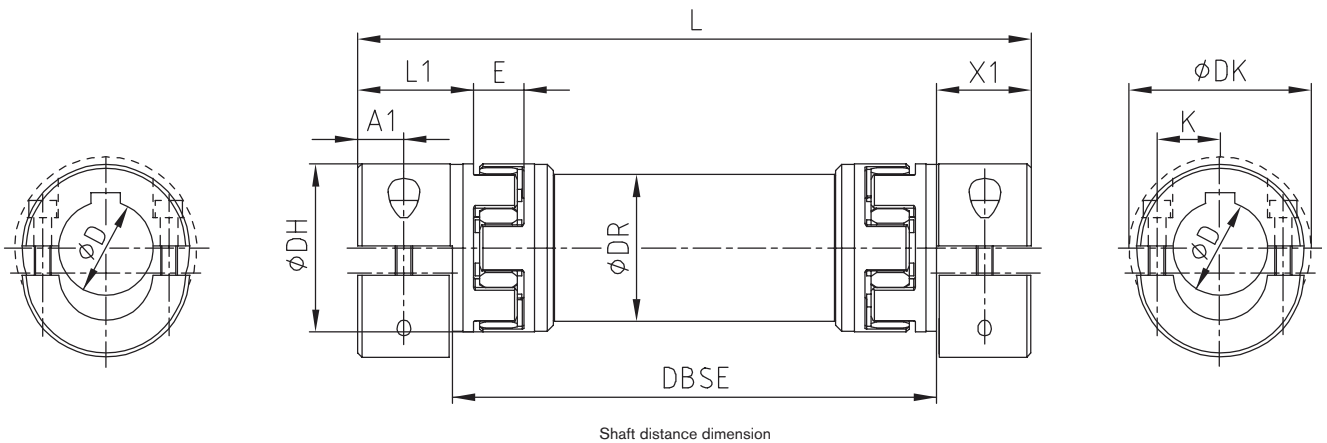

#### ROTEX® GS Type ZR3 - Hub material aluminium/intermediate pipe material aluminium

Size	Dimensions [mm]														Cap screws DIN EN ISO 4762	
	D <sub>max</sub>	DH	L1	L	X1	E	DBSE		L = DBSE + 2 x X1		DR	DK	A1	K	M	T <sub>A</sub> [Nm]
							min.	max.	min.	max.						
14	15	30	18.5	36.0	14.5	13	72	2971	101	3000	28	33.3	7.5	10.5	M 4	2.9
19	20	40	25	49.0	17.5	16	98	2965	133	3000	40	46	8.0	14.5	M 6	10
24	30	55	30	59.0	22.0	18	121	3456	165	3500	50	57.5	10.5	20	M 6	10
28	38	65	35	67.0	25.0	20	137	3950	187	4000	60	73	11.5	25	M 8	25
38	45	80	45	83.5	33.0	24	169	3934	235	4000	70	83.5	15.5	30	M 8	25
42	50	95	50	93.0	36.5	26	180	3927	253	4000	80	93.5	18.0	32	M 10	49
48	55	105	56	100.0	39.5	28	202	3921	281	4000	100	105	18.5	36	M 12	86

#### Technical data of type ZR3

Size	Spider GS <sup>1)</sup> torque T <sub>KN</sub> [Nm]		Moment of inertia [10 <sup>-3</sup> kgm <sup>2</sup> ]			Static torsion spring stiffness <sup>3)</sup> [Nm/rad]
	98 ShA	64 ShD	Hub <sup>2)</sup>	ZR hub	Pipe/meter	
14	12.5	16.0	0.00362	0.00238	0.088	858
19	21.0	26.0	0.02002	0.01304	0.329	3243.6
24	60.0	75.0	0.07625	0.04481	0.673	6631.8
28	160	200	0.17629	0.10950	1.199	11814.1
38	325	405	0.50385	0.2572	2.972	29290.4
42	450	560	1.12166	0.5523	4.560	44929.7
48	525	655	1.87044	1.1834	9.251	91158.2

<sup>1)</sup> For selections see page 22 et seqq./other spiders see page 121.

<sup>2)</sup> with D<sub>max</sub>

<sup>3)</sup> Torsion spring stiffness with a length of 1 m of intermediate pipe with L<sub>pipe</sub> = LZR - 2 · L

With inquiries and orders please specify the shaft distance dimension DBSE along with the maximum speed to review the critical bending speed. See diagramme on page 125.

The intermediate pipe can be combined with other hub types, but in that case it can no longer be radially disassembled. Please specify the required shaft distance dimension in your order. Straightness/concentricity of pipes according to DIN EN 755-1.

For diagramme for coupling selection see page 125.

Ordering example:	ROTEX® GS 24	ZR3	1200 mm	98 ShA-GS	7.5 - Ø24		7.5 - Ø24	
	Coupling size	Type	Shaft distance dimension (DBSE)	Spider hardness	Hub type	Finish bore	Hub type	Finish bore

# ROTEX® GS ZRS

## Backlash-free intermediate shaft couplings

### Intermediate shaft coupling with aluminium pipe

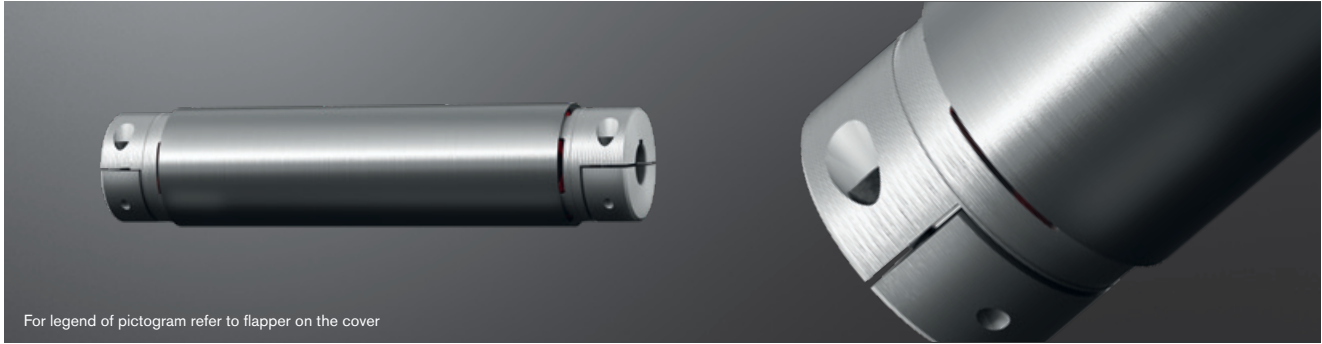

For legend of pictogram refer to flapper on the cover



#### Type ZRS

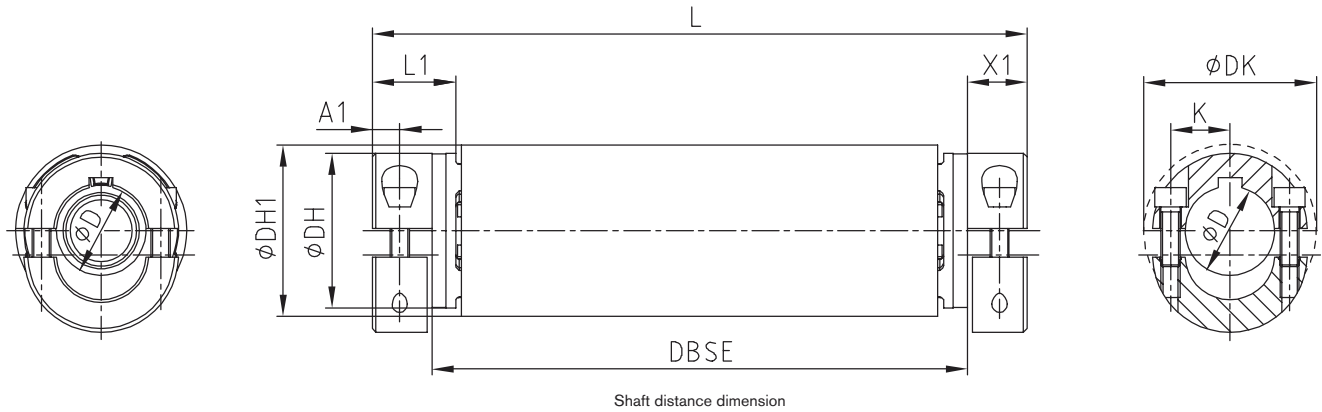

ROTEX® type ZRS													
Size	Dimensions [mm]								Intermediate pipe Torsion spring stiffness C <sup>4)</sup> [Nm/rad]	Cap screws DIN EN ISO 4762		L	Min. DBSE
	D <sub>max</sub>	DH	L1	X1	A1	K	DK	DH1		M	Tightening torque T <sub>A</sub> [Nm]		
19	20	40	25	17.5	8.0	14.5	46.0	45	3800	M6 x 16	14	L = DBSE + 2 x X1	33
24	24	55	30	22.0	15.0	20.0	57.5	60	11100	M6 x 20	14		37
28	38	65	35	25.0	17.5	25.0	73.0	72	23600	M8 x 25	34		40
38	45	80	45	33.0	22.5	30.0	83.5	87	43800	M8 x 30	34		49
42	55	95	50	36.5	25.0	30.0	97.0	103	82600	M10 x 35	67		53

<sup>4)</sup> Torsion spring stiffness with an intermediate pipe length of 1 m  
With vertical applications a support washer must be used (please specify in your order).  
Insertion dimension of shaft X1, to make sure the coupling can be radially assembled/disassembled.

For diagramme for coupling selection see page 50.

### Types of hubs

Type 7.5

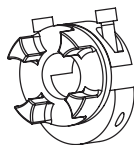

Clamping hub type DH without feather keyway for double-cardanic connections

Type 7.6

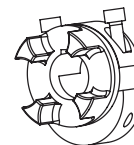

Clamping hub type DH with feather keyway for double-cardanic connections

Ordering example:	ROTEX® GS 24	ZRS	1200 mm	98 ShA-GS	7.5 - Ø24		7.5 - Ø24	
	Coupling size	Type	Shaft distance dimension (DBSE)	Spider hardness	Hub type	Finish bore	Hub type	Finish bore

# ROTEX® GS ZR1 and ZR2

## Backlash-free intermediate shaft couplings

### Intermediate shaft couplings with steel pipe/steel shaft

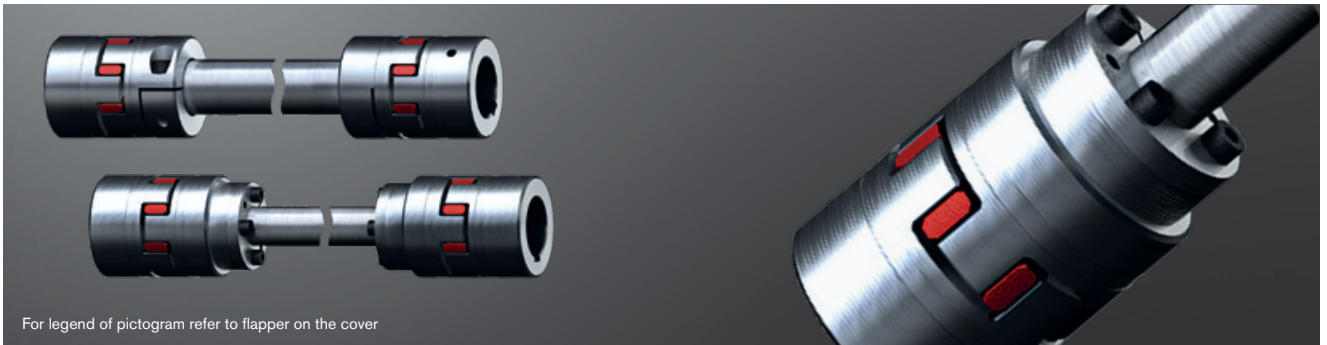

For legend of pictogram refer to flapper on the cover



#### ROTEX® GS Type ZR1

Size	Spider GS <sup>1)</sup> torque T <sub>KN</sub> [Nm]			Dimensions [mm]										Cap screws DIN EN ISO 4762			Friction torque T <sub>R</sub> [Nm]	
	98 ShA	57 ShD	64 ShD	D <sub>max</sub> <sup>2)</sup>	DH	L1, L2	LH	E	B1	S	W	DBSE	Minimum dimension for DBSE	L	DR <sup>3)</sup>	M		T <sub>A</sub> [Nm]
14 ZR1	12.5	-	16.0	16	30	11	35	13	10	1.5	11.5	Please specify with inquiries and orders.	71	DBSE+22	14x2.5	M 3	1.34	6.1
19 ZR1	21.0	23	26.0	24	40	25	66	16	12	2.0	14.0		110	DBSE+50	20x3.0	M 6	10.5	34
24 ZR1	60	68	75	28	55	30	78	18	14	2.0	16.0		128	DBSE+60	25x2.5	M 6	10.5	45
28 ZR1	160	180	200	38	65	35	90	20	15	2.5	17.5		145	DBSE+70	35x4.0	M 8	25	105
38 ZR1	325	365	405	45	80	45	114	24	18	3.0	21.0		180	DBSE+90	40x4.0	M 8	25	123

#### ROTEX® GS Type ZR2

Size	Spider GS <sup>1)</sup> torque T <sub>KN</sub> [Nm]			Dimensions [mm]										Precision tube		Clamping set size KTR 250	Clamping screws DIN EN ISO 4762	Tightening torque T <sub>A</sub> [Nm]		
	98 ShA	57 ShD	64 ShD	D <sub>max</sub> <sup>2)</sup>	DH	L1, L2	LC1	LH	E	B1	S	W	DBSE	Minimum dimension for DBSE	L				DR <sup>3)</sup> [mm]	C <sub>2</sub> <sup>4)</sup> [Nm/rad]
14 ZR2	12.5	-	16.0	16	30	11	26	50	13	10	1.5	11.5	Please specify with inquiries and orders.	109	DBSE+22	10x2.0	68.36	10x16	M 4	5.6
19 ZR2	21.0	23	26.0	24	40	25	26	67	16	12	2.0	14.0		120	DBSE+50	12x2.0	130	12x18	M 4	5.6
24 ZR2	60	68	75	28	55	30	38	86	18	14	2.0	16.0		156	DBSE+60	20x3.0	954.9	20x28	M 6	17.0
28 ZR2	160	180	200	38	65	35	45	100	20	15	2.5	17.5		177	DBSE+70	25x2.5	1811	25x34	M 6	17.0
38 ZR2	325	365	405	45	80	45	45	114	24	18	3.0	21.0		192	DBSE+90	32x3.5	5167	32x43	M 6	17.0
42 ZR2	450	-	560	55	95	50	52	128	26	20	3.0	23.0		214	DBSE+100	40x4.0	11870	40x53	M 6	17.0
48 ZR2	525	-	655	62	105	56	70	154	28	21	3.5	24.5		261	DBSE+112	45x4.0	17486	45x59	M 8	41.0
55 ZR2	685	-	825	74	120	65	80	175	30	22	4.0	26.0		288	DBSE+130	55x4.0	33543	55x71	M 8	41.0
65 ZR2	940	-	1175	80	135	75	80	185	35	26	4.5	30.5		387	DBSE+150	60x4.0	44362	60x77	M 8	41.0

<sup>1)</sup> For selections see page 22 et seqq./other spiders see page 121.

<sup>2)</sup> Dependent on hub type. Hub types can be freely selected, for summary see page 126.

<sup>3)</sup> Must be remachined, if necessary.

<sup>4)</sup> Torsion spring stiffness with a length of 1 m of intermediate pipe.

With inquiries and orders please specify the shaft distance dimension DBSE along with the maximum speed to review the critical bending speed.

With vertical applications a support washer must be used (please specify in your order).

Straightness/concentricity of pipes according to DIN EN 10305-1.

Ordering example:

ROTEX® GS 24	ZR1	1000 mm	98 ShA-GS	1.0 - Ø24		2.5 - Ø24	
Coupling size	Type	Shaft distance dimension DBSE	Spider hardness	Hub type	Finish bore	Hub type	Finish bore

Type ZR1

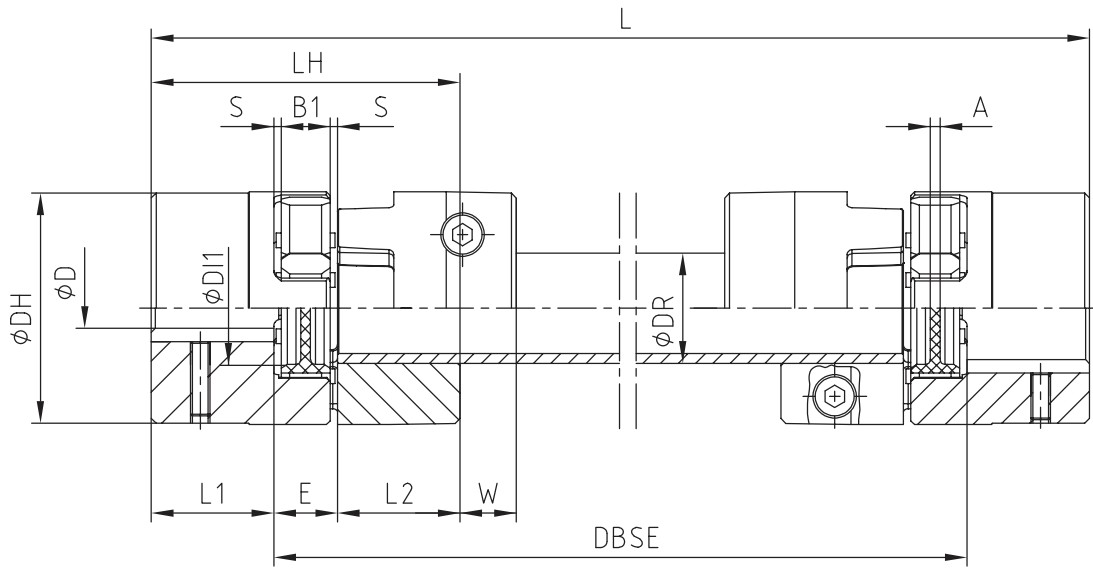

Type ZR2

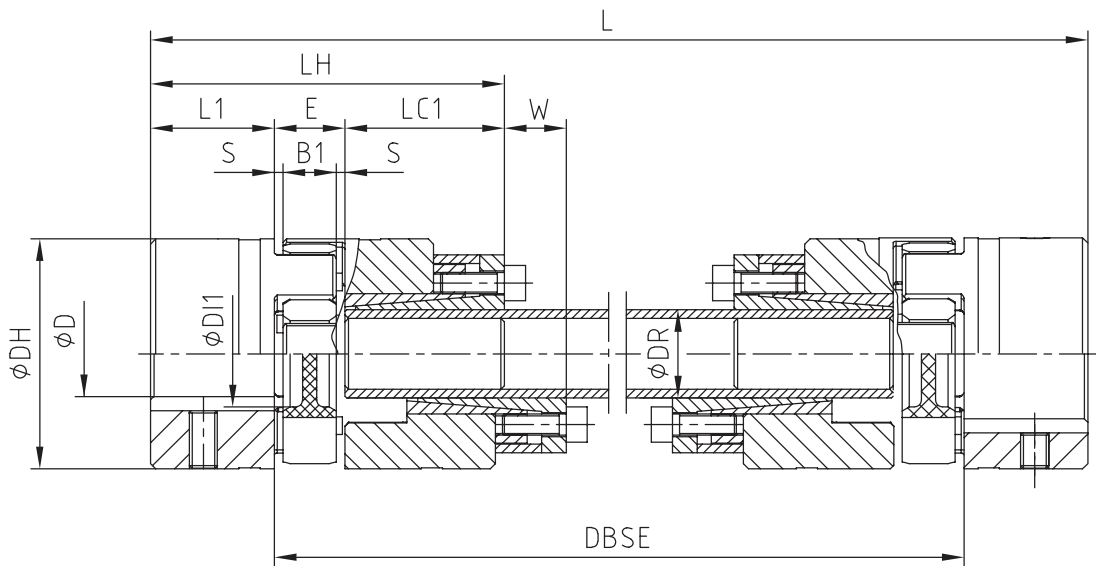

# TOOLFLEX®

## Metal bellow-type couplings

### Technical description

TOOLFLEX® is a metal bellow-type coupling, a coupling system which has proven in the field with numerous applications. The metal bellow optimally compensates for axial, radial and angular displacements. At the same time its geometric shape allows for high torsion spring stiffness and a low mass moment of inertia. TOOLFLEX® is manufactured in twelve sizes for maximum torques up to 600 Nm. Its main application ranges are both positioning drives, e. g. ball spindles with a high pitch, and indexing tables or planetary and worm gears with small gear ratios.

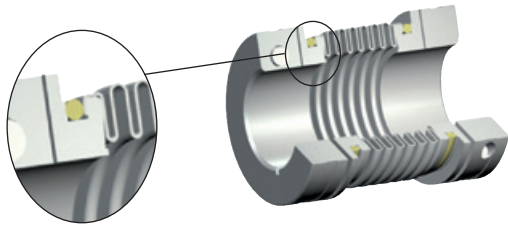

Subject to its proven bonding technique a non-positive, backlash-free connection of the aluminium hubs with the multi-layer bellows made of stainless steel is generated. The flanged insert connection for sizes 16 to 55 ensures torque transmission of every single bellow layer. Since TOOLFLEX® is a metal coupling, it remains fatigue-endurable in the high-temperature range up to a maximum of 200 °C. Apart from that it is resistant to the effect of media respectively critical operating conditions.

The renowned shaft-hub-connection made by clamping hubs ensures an easy assembly by a radial clamping screw. Subject to two slots in the hub there is no deformation of the bellow when tightening the clamping screw. For higher friction torques type KN with taper hubs can be used.

Double slotted clamping hub

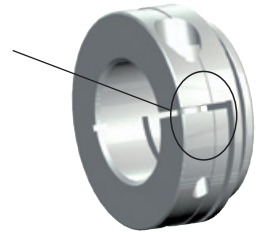

### Types



Type with setscrew

Type with clamping hubs

Type S-H / M-H

Type ZR

Type PI

Type KN

Type CF

Summary											
Size	Type	Bel-low-hub-connection	Torque of bellow [Nm]		Standard types				Special types		
			T <sub>KN</sub> [Nm]	T <sub>K max</sub> [Nm]	Max. speed [rpm]				PI	KN 6.5	CF
					Setscrew 1.0 / 1.1	Clamping hubs 2.5 / 2.6	S-H / M-H 7.8 / 7.9	ZR 7.5 / 7.6			
5	S	Bonded Maximum ambient temperature 100 °C	0.1	0.15	47,700						
	M										
7	S		1	1.5	31,800	31,800					
	M										
9	S		1.5	2.25	23,800	23,800					
	M										
12	S		2	3	19,000	19,100					
	M										
16	S		5	7.5	14,900	14,900					
	M										
20	S		15	22.5	11,900	11,900	9,550	3,000	11,900		
	M										
30	S	Flanged Maximum ambient temperature 120 °C	35	52.5	8,700	6,950	3,000	8,700	15,280	8,700	
	M										
38	S		65	97.5	7,350	5,850	3,000	7,350	12,600	7,350	
	M										
42	S		95	142.5	6,820			6,820	11,580	6,820	
	M										
45	S		170	255	5,750	4,750	3,000	5,750	9,300	5,750	
	M										
55 Al	S		340	510	4,800						
	M										
55	S		Welded Maximum ambient temperature 200 °C	340	510	4,800			4,800	7,870	
	M										
65	S	600		900	3,850						
	M										

# TOOLFLEX®

## Metal bellow-type couplings

### Types of hubs

Due to the use of TOOLFLEX® for many different applications and mounting conditions, this coupling system is available with various hub types and two different lengths of bellows. A combination of the components forms a type. TOOLFLEX® is supplied as a complete unit; a supply of individual components is not possible.



**Type 1.0**  
with feather keyway and setscrew  
Positive-locking power transmission. Permissible torque depending on the permissible surface pressure. Not suitable for backlash-free power transmission with heavily reversing operation.



**Type 1.1**  
without feather keyway, with setscrew  
Non-positive torque transmission. Suitable for backlash-free transmission of very low torques.



**Type 1.3**  
with spline bore  
Positive-locking power transmission. Spline on request of customers (e. g. for shaft with flattening).



**Type 1.2**  
without feather keyway, without setscrew  
For low torques. Suitable for bonding or pressing of the shaft.



**Type 2.5** clamping hub  
double slotted, without feather keyway  
Frictionally engaged, backlash-free shaft-hub-connection. Transmittable torques depending on bore diameter.



**Type 2.6** clamping hub  
double slotted, with feather keyway  
Positive-locking power transmission with additional friction fit. The friction fit avoids resp. reduces reverse backlash. Surface pressure of the keyway connection is reduced.



**Type 7.5** clamping hub type DH  
without feather keyway for double-cardanic connection  
Frictionally engaged, backlash-free shaft-hub-connection for radial assembly of coupling. Transmittable torques depending on bore diameter.



**Type 7.6** clamping hub type DH  
with feather keyway for double-cardanic connection  
Positive-locking power transmission with additional friction fit for radial assembly of coupling. The friction fit avoids resp. reduces reverse backlash. Surface pressure of the keyway connection is reduced.

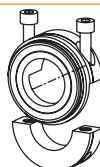

**Type 7.8** clamping hub type H  
without feather keyway for single-cardanic connection  
Frictionally engaged, backlash-free shaft-hub-connection for radial assembly of coupling. Transmittable torques depending on bore diameter.



**Type 7.9** clamping hub type H  
with feather keyway for single-cardanic connection  
Positive-locking power transmission with additional friction fit for radial assembly of coupling. The friction fit avoids resp. reduces reverse backlash. Surface pressure of the keyway connection is reduced.

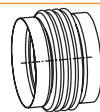

**Bellow type S**  
Bellow with 4 layers made of stainless steel; compact design with high torsion spring stiffness.

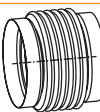

**Bellow type M**  
Bellow with 6 layers made of stainless steel; realizing large shaft distance dimensions and displacements.

### Special designs on request of customers

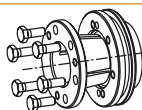

**Type 6.5** taper hub KN  
Integrated frictionally engaged shaft-hub-connection for the transmission of higher torques in the area of the shaft-hub-connection.



**Flange**  
Flange to connect to customer's component. Special dimensions on request.

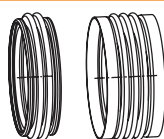

**Special bellows**  
Bellows with 1, 2 or 3 layers available on request.

# TOOLFLEX® S

## Metal bellow-type couplings

### Type S: Hubs with setscrews

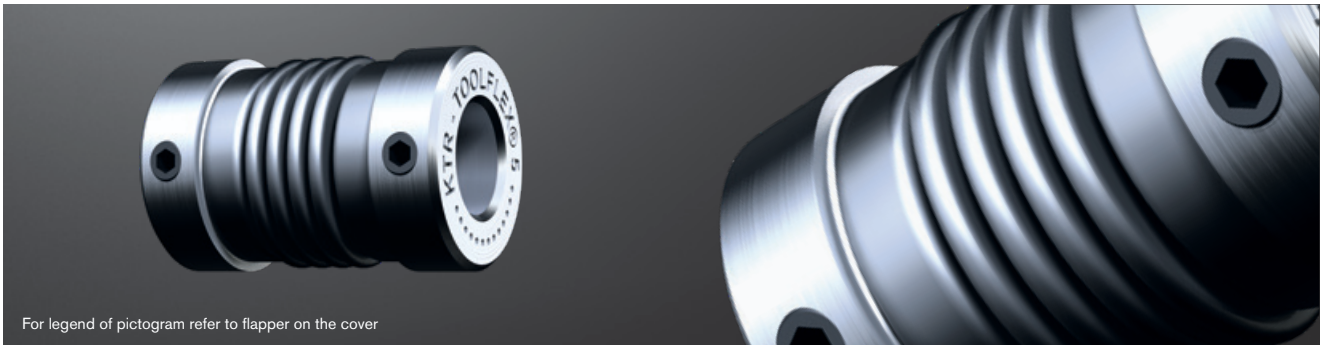

For legend of pictogram refer to flapper on the cover

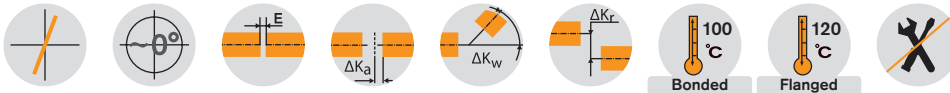

TOOLFLEX® S type 1.1

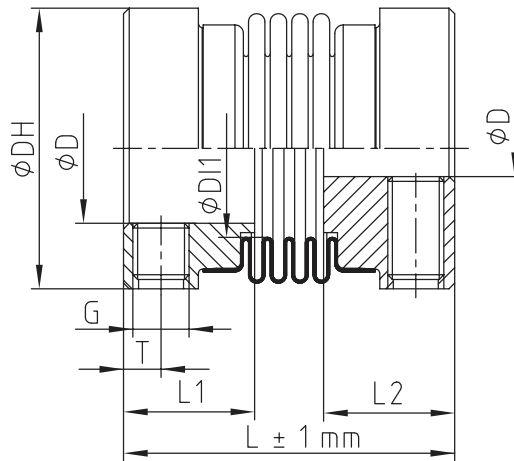

TOOLFLEX® S with setscrew (type 1.1) - Hub material aluminium/bellow material stainless steel

Size	Bellow-hub-connection	Torque of bellow T <sub>KN</sub> <sup>1)</sup> [Nm]	Max. speed [rpm]	Dimensions [mm]									Perm. displacements			Torsion spring stiffness C <sub>T</sub> [Nm/rad]	Weight <sup>3)</sup> [kg]
				Finish bore D		General				Setscrew			Axial [mm]	Radial [mm]	Angular [degree]		
				min.	max.	DH	DI1	L	L1, L2	G	T	Z = number <sup>2)</sup>					
5		0.1	47700	2	5	10	6	15	6	M 2	1.8	1	±0.30	0.10	0.7	97	0.0027
7	4)	1.0	31800	3	8	15	9	18	7	M 3	2.0	1	±0.30	0.10	0.7	390	0.005
9		1.5	23800	3	10	20	12	21	8	M 3	2.2	2	±0.35	0.15	1.0	750	0.010
12		2.0	19000	4	14	25	16	27.5	11	M 4	2.8	2	±0.40	0.15	1.0	1270	0.017
16		5.0	14900	5	18	32	20	37	13	M 5	4	2	±0.30	0.15	1.0	4500	0.046
20	5)	15	11900	6	25	40	27	42	15	M 5	5	2	±0.40	0.15	1.0	9600	0.076

<sup>1)</sup> For selections see page 22 et seqq.

<sup>2)</sup> Number per hub; from size 9: 2 x 120° offset.

<sup>3)</sup> Figures refer to the complete coupling with max. bore.

<sup>4)</sup> Bonded

<sup>5)</sup> Flanged

### Types of hubs

Type 1.0



Hub with feather keyway and setscrew

Type 1.1



Hub without feather keyway, with setscrew

Type 1.2



Hub without feather keyway, without setscrew

Type 1.3



Hub with spline bore

Ordering example:

TOOLFLEX® 7 S	1.1 - Ø4		1.1 - Ø6	
Size and type of coupling	Hub type	Finish bore	Hub type	Finish bore

# TOOLFLEX® M

## Metal bellow-type couplings

### Type M: Hubs with setscrews

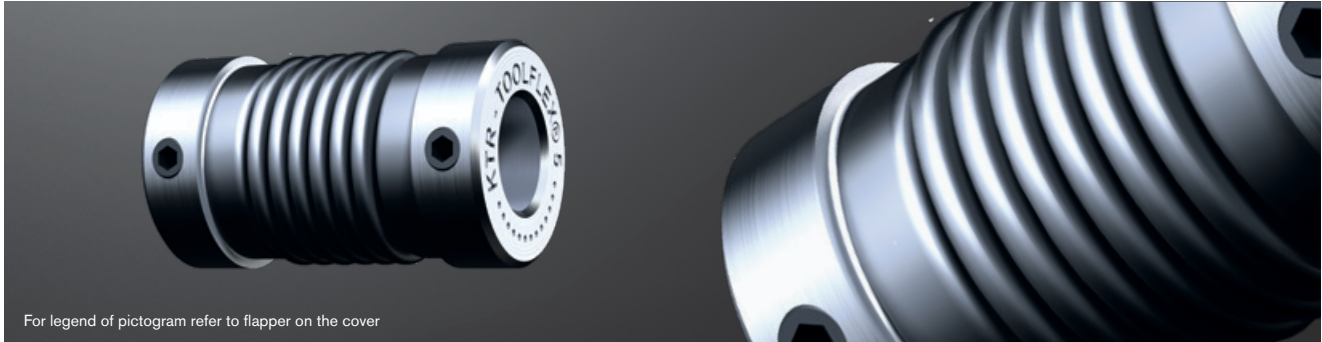

For legend of pictogram refer to flapper on the cover

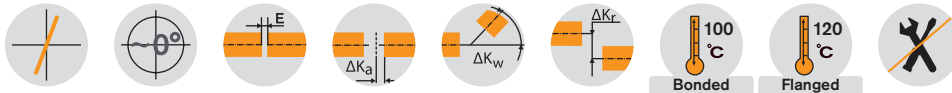

TOOLFLEX® M type 1.1

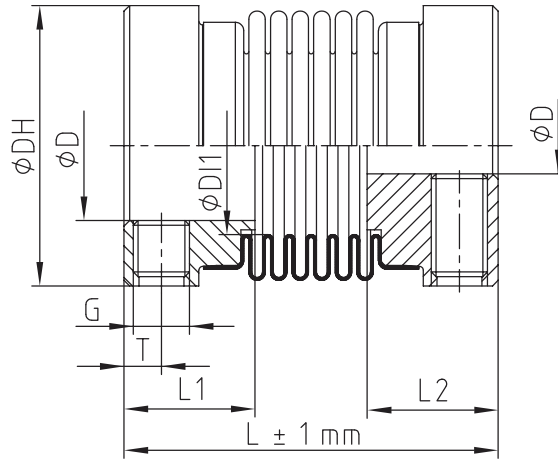

TOOLFLEX® M with setscrew (type 1.1) - Hub material aluminium/bellow material stainless steel

Size	Bellow-hub-connection	Torque of bellow T <sub>KN</sub> <sup>1)</sup> [Nm]	Max. speed [rpm]	Dimensions [mm]										Perm. displacements			Torsion spring stiffness C <sub>T</sub> [Nm/rad]	Weight <sup>3)</sup> [kg]
				Finish bore D		General				Setscrew				Axial [mm]	Radial [mm]	Angular [degree]		
				min.	max.	DH	D1	L	L1, L2	G	T	Z = number <sup>2)</sup>						
5		0.1	47700	2	5	10	6	17	6	M 2	1.8	1	±0.40	0.15	1.0	75	0.003	
7	4)	1.0	31800	3	8	15	9	20	7	M 3	2.0	1	±0.40	0.15	1.0	300	0.006	
9		1.5	23800	3	10	20	12	24	8	M 3	2.2	2	±0.50	0.20	1.5	580	0.011	
12		2.0	19000	4	14	25	16	31	11	M 4	2.8	2	±0.60	0.20	1.5	980	0.019	
16	5)	5.0	14900	5	18	32	20	41	13	M 5	4	2	±0.50	0.20	1.5	3050	0.049	
20		15	11900	6	25	40	27	49	15	M 5	5	2	±0.60	0.20	1.5	6600	0.082	

<sup>1)</sup> For selections see page 22 et seqq.

<sup>2)</sup> Number per hub; from size 9: 2 x 120° offset.

<sup>3)</sup> Figures refer to the complete coupling with max. bore.

<sup>4)</sup> Bonded

<sup>5)</sup> Flanged

### Types of hubs

Type 1.0



Hub with feather keyway and setscrew

Type 1.1



Hub without feather keyway, with setscrew

Type 1.2

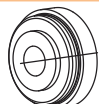

Hub without feather keyway, without setscrew

Type 1.3



Hub with spline bore

Ordering example:

TOOLFLEX® 7 M	1.1 - Ø4		1.1 - Ø6	
Size and type of coupling	Hub type	Finish bore	Hub type	Finish bore

# TOOLFLEX® S

## Metal bellow-type couplings

### Type S: with clamping hubs

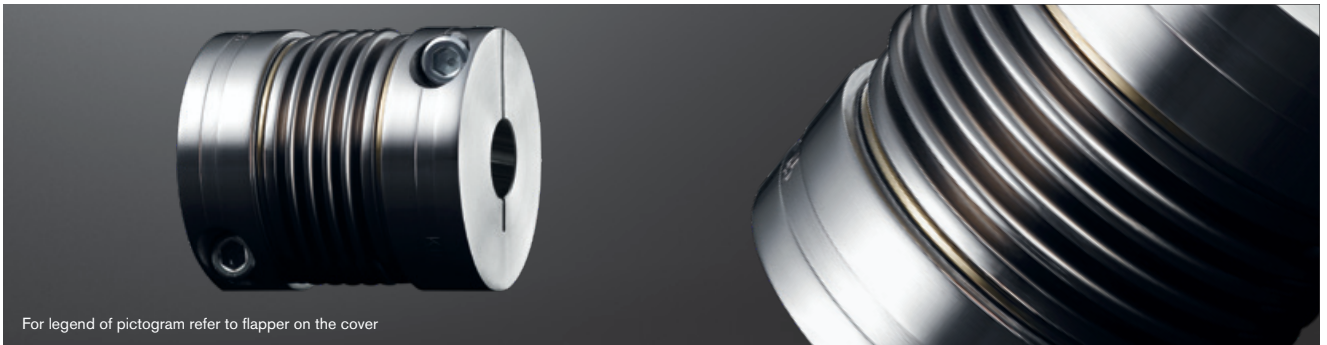

For legend of pictogram refer to flapper on the cover

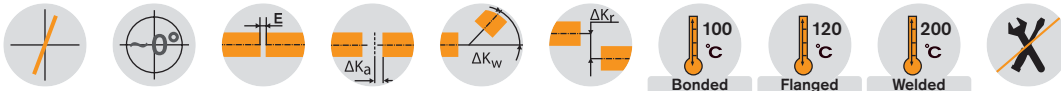

#### TOOLFLEX® Type S with clamping hubs - Hub material aluminium (size 55/65 steel)/bellow material stainless steel

Size	Dimensions [mm]											
	Finish bore D		General					Clamping screws DIN EN ISO 4762				
	min.	max.	L	L1, L2	E	DH	DI1	M	DK	A1	K	T <sub>A</sub> [Nm]
7	3	7	24	9	6	15	9	M 2	16.5	3.2	5	0.37
9	3	9	29	11	7	20	12	M 2.5	21.5	3.5	7.1	0.76
12	4	12	34.5	13	8.5	25	16	M 3	26.5	4	8.5	1.34
16	5	16	45	17.0	11	32	20	M 4	35.0	5	12.0	2.9
20	8	20	55	21.5	12	40	27	M 5	43.5	6	14.5	6
30	10	30	63	23.0	17	55	33	M 6	58.0	7	19	10
38	12	38	69	25.5	18	65	42	M 8	72.6	9	25	25
42	14	42	84	30.0	24	70	46	M 8	76.1	9	27	25
45	14	45	86.5	32.0	22.5	83	58	M 10	89.0	11	30	49
55 Al	20	55	111	40.0	31	100	73	M 12	106.0	14	37	86
55 <sup>3)</sup>	20	55	111	40.0	31	100	73	M 12	106.0	14	37	120
65 <sup>3)</sup>	30	65	126	45.0	36	125	95	M 14	127.2	15	45	190

#### Technical data

Size	Bellow-hub-connection	Torque of bellow T <sub>KN</sub> [Nm]	Max. speed [rpm]	Hub material	Moment of inertia <sup>2)</sup> [x10 <sup>-6</sup> kgm <sup>2</sup> ]	Torsion spring stiffness C <sub>T</sub> [Nm/rad]	Axial stiffness C <sub>a</sub> [N/mm]	Radial stiffness C <sub>r</sub> [N/mm]	Perm. displacements			Weight <sup>2)</sup> [kg]
									Axial [mm]	Radial [mm]	Angular [degree]	
7	Bonded	1	31800	Aluminium	0.26	390	—	—	±0.3	0.10	0.7	0.007
9		1.5	23800	Aluminium	0.97	750	—	—	±0.35	0.15	1.0	0.014
12		2	19100	Aluminium	2.6	1270	—	—	±0.4	0.15	1.0	0.025
16		5	14900	Aluminium	9	4500	43	138	±0.3	0.15	1.0	0.06
20	Flanged	15	11950	Aluminium	30	9600	63	189	±0.4	0.15	1.0	0.12
30		35	8700	Aluminium	114	17800	97	233	±0.5	0.20	1.5	0.24
38		65	7350	Aluminium	245	37400	108	318	±0.6	0.20	1.5	0.35
42		95	6820	Aluminium	396	54700	120	499	±0.6	0.20	1.5	0.49
45		170	5750	Aluminium	931	95800	132	738	±0.9	0.20	1.5	0.82
55 Al		340	4800	Aluminium	1665	144100	160	894	±1.1	0.25	1.5	1.50
55 <sup>3)</sup>	340	4800	Steel	4996	144100	160	894	±1.0	0.25	1.5	3.20	
65 <sup>3)</sup>	600	3850	Steel	13318	322740	212	1365	±1.0	0.30	1.5	5.50	

<sup>1)</sup> For selections see page 22 et seqq.

<sup>2)</sup> Figures refer to the complete coupling with max. bore.

<sup>3)</sup> Hub made of steel welded with bellow.

#### Review of shaft-hub-connection: Friction torques T<sub>R</sub> [Nm] for hub type 2.5

Size	Ø3	Ø4	Ø5	Ø6	Ø7	Ø8	Ø9	Ø10	Ø11	Ø12	Ø14	Ø15	Ø16	Ø18	Ø19	Ø20	Ø24	Ø25	Ø28	Ø30	Ø32	Ø35	Ø38	Ø40	Ø42	Ø45	Ø50	Ø55	Ø60	Ø65
7	0.7	0.9	1.0	1.2	1.4																									
9	1.2	1.5	1.9	2.2	2.5	2.8	3.1																							
12		2.3	2.8	3.3	3.8	4.3	4.8	5.2	5.7	6.1																				
16			5.4	6.4	7.3	8.2	9.1	10.0	10.9	11.7	13.4	14.2	15.0																	
20						13.5	15.0	16.5	18.0	19.3	22.1	23.5	24.8	27.4	28.7	30.0														
30										26	28	32	34	36	40	42	43	51	53	58	61									
38											63	67	71	79	82	86	101	105	115	122	129	139	148							
42											63	67	71	79	83	87	102	106	117	124	130	141	150	157	163					
45																136	160	166	183	194	206	222	238	248	259	274				
55 Al																205	242	251	277	295	312	337	362	378	394	418	457	494		
55 <sup>3)</sup>																341	354	391	416	440	475	510	533	556	589	644	697			
65 <sup>3)</sup>																			576	610	660	710	743	775	823	901	977	1051	1124	

Ordering example:	TOOLFLEX® 30 S	Ø25	Ø25	Ø30	Ø30
	Size and type of coupling	Hub type	Finish bore	Hub type	Finish bore

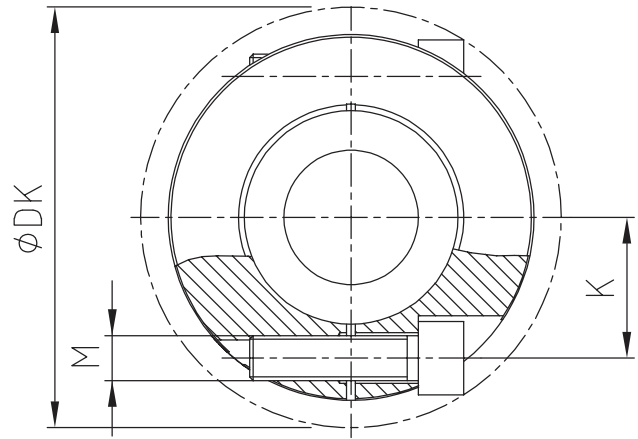
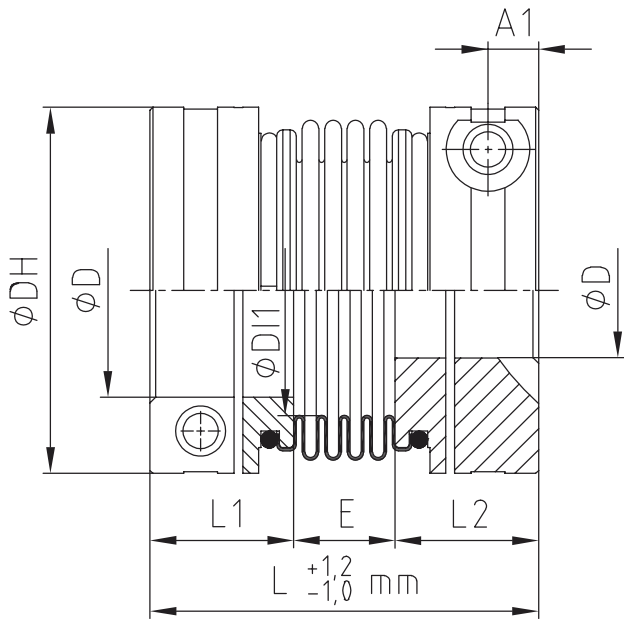

ROTEX® GS

Backlash-free  
servo couplings

ROTEX® GS HP

**Other types:**  
Type for FANUC motors

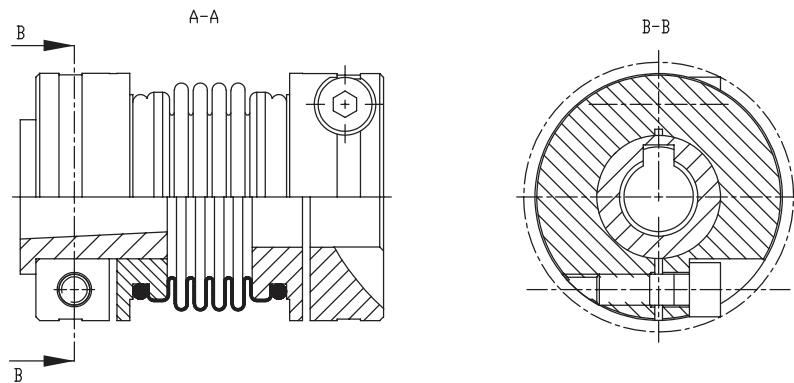

TOOLFLEX®

## Types of hubs

Type 2.5



Clamping hub double slot without feather keyway

Type 2.6

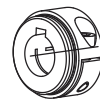

Clamping hub double slot with feather keyway

RADEX®-NC

# TOOLFLEX® M

## Metal bellow-type couplings

### Type M: with clamping hubs

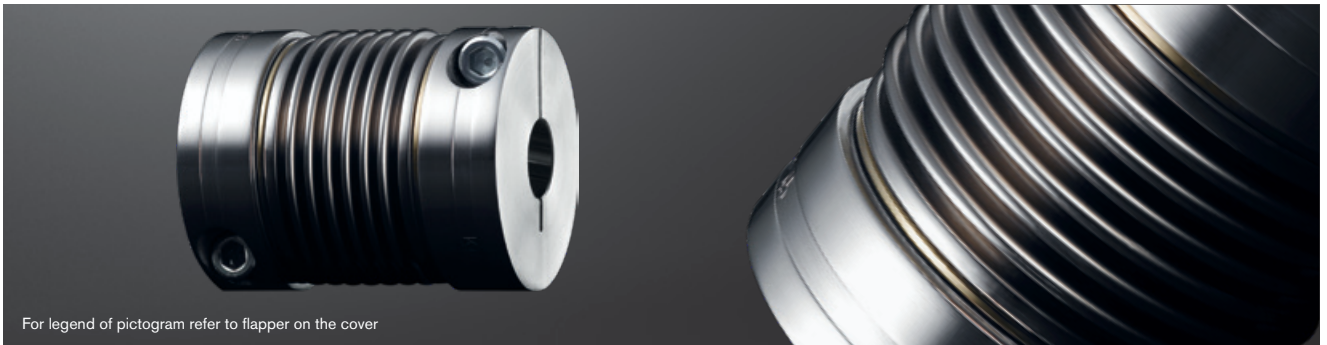

For legend of pictogram refer to flapper on the cover

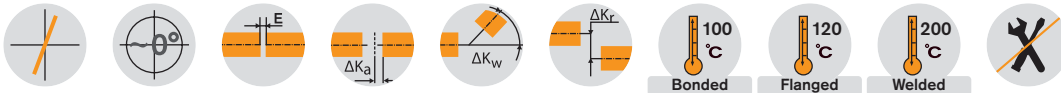

#### TOOLFLEX® Type M with clamping hubs - Hub material aluminium (size 55/65 steel)/bellow material stainless steel

Size	Dimensions [mm]											
	Finish bore D		General					Clamping screws DIN EN ISO 4762				
	min.	max.	L	L1, L2	E	DH	DI1	M	DK	A1	K	T <sub>A</sub> [Nm]
7	3	7	26	9	8	15	9	M 2	16.5	3.2	5	0.37
9	3	9	32	11	10	20	12	M 2.5	21.5	3.5	7.1	0.76
12	4	12	38	13	12	25	16	M 3	26.5	4	8.5	1.34
16	5	16	49	17.0	15	32	20	M 4	35.0	5	12	2.9
20	8	20	62	21.5	19	40	27	M 5	43.5	6	14.5	6
30	10	30	72	23.0	26	55	33	M 6	58.0	7	19	10
38	12	38	81	25.5	30	65	42	M 8	72.6	9	25	25
42	14	42	95	30.0	35	70	46	M 8	76.1	9	27	25
45	14	45	103	32.0	39	83	58	M 10	89.0	11	30	49
55 Al	20	55	125	40.0	45	100	73	M 12	106.0	14	37	86
55 <sup>3)</sup>	20	55	125	40.0	45	100	73	M 12	106.0	14	37	120
65 <sup>3)</sup>	30	65	142	45.0	52	125	95	M 14	127.2	15	45	190

#### Technical data

Size	Bellow-hub-connection	Torque of bellow T <sub>KN</sub> [Nm] <sup>1)</sup>	Max. speed [rpm]	Hub material	Moment of inertia <sup>2)</sup> [x10 <sup>-8</sup> kgm <sup>2</sup> ]	Torsion spring stiffness C <sub>T</sub> [Nm/rad]	Axial stiffness C <sub>a</sub> [N/mm]	Radial stiffness C <sub>r</sub> [N/mm]	Perm. displacements			Weight <sup>2)</sup> [kg]
									Axial [mm]	Radial [mm]	Angular [degree]	
7	Bonded	1	31800	Aluminium	0.3	300	—	—	±0.4	0.15	1.0	0.008
9		1.5	23800	Aluminium	1.0	580	—	—	±0.5	0.20	1.5	0.015
12		2	19100	Aluminium	2.7	980	—	—	±0.6	0.20	1.5	0.03
16		5	14900	Aluminium	10	3050	29	92	±0.5	0.20	1.5	0.06
20	Flanged	15	11950	Aluminium	32	6600	42	126	±0.6	0.20	1.5	0.14
30		35	8700	Aluminium	123	14800	65	155	±0.8	0.25	2.0	0.31
38		65	7350	Aluminium	262	24900	72	212	±0.8	0.25	2.0	0.45
42		95	6820	Aluminium	427	36500	80	333	±0.8	0.25	2.0	0.52
45		170	5750	Aluminium	1020	64000	88	492	±1.0	0.25	2.0	1.13
55 Al		340	4800	Aluminium	1706	96100	107	598	±1.1	0.30	2.0	2.0
55 <sup>3)</sup>		340	4800	Steel	5118	96100	107	598	±1.0	0.30	2.0	3.3
65 <sup>3)</sup>	600	3850	Steel	13727	226550	135	910	±2.0	0.35	2.0	5.6	

<sup>1)</sup> For selections see page 22 et seqq.

<sup>2)</sup> Figures refer to the complete coupling with max. bore.

<sup>3)</sup> Hub made of steel welded with bellow.

#### Review of shaft-hub-connection: Friction torques T<sub>R</sub> [Nm] for hub type 2.5

Size	Ø3	Ø4	Ø5	Ø6	Ø7	Ø8	Ø9	Ø10	Ø11	Ø12	Ø14	Ø15	Ø16	Ø18	Ø19	Ø20	Ø24	Ø25	Ø28	Ø30	Ø32	Ø35	Ø38	Ø40	Ø42	Ø45	Ø50	Ø55	Ø60	Ø65
7	0.7	0.9	1.0	1.2	1.4																									
9	1.2	1.5	1.9	2.2	2.5	2.8	3.1																							
12		2.3	2.8	3.3	3.8	4.3	4.8	5.2	5.7	6.1																				
16			5.4	6.4	7.3	8.2	9.1	10.0	10.9	11.7	13.4	14.2	15.0																	
20						13.5	15.0	16.5	18.0	19.3	22.1	23.5	24.8	27.4	28.7	30.0														
30										26	28	32	34	36	40	42	43	51	53	58	61									
38											63	67	71	79	82	86	101	105	115	122	129	139	148							
42											63	67	71	79	83	87	102	106	117	124	130	141	150	157	163					
45																136	160	166	183	194	206	222	238	248	259	274				
55 Al																205	242	251	277	295	312	337	362	378	394	418	457	494		
55 <sup>3)</sup>																341	354	391	416	440	475	510	533	556	589	644	697			
65 <sup>3)</sup>																			576	610	660	710	743	775	823	901	977	1051	1124	

Ordering example:	TOOLFLEX® 30 M	2.5 - Ø25				2.5 - Ø30			
	Size and type of coupling	Hub type	Finish bore	Hub type	Finish bore				

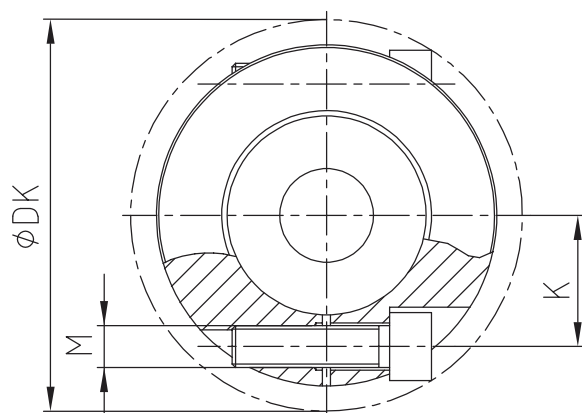
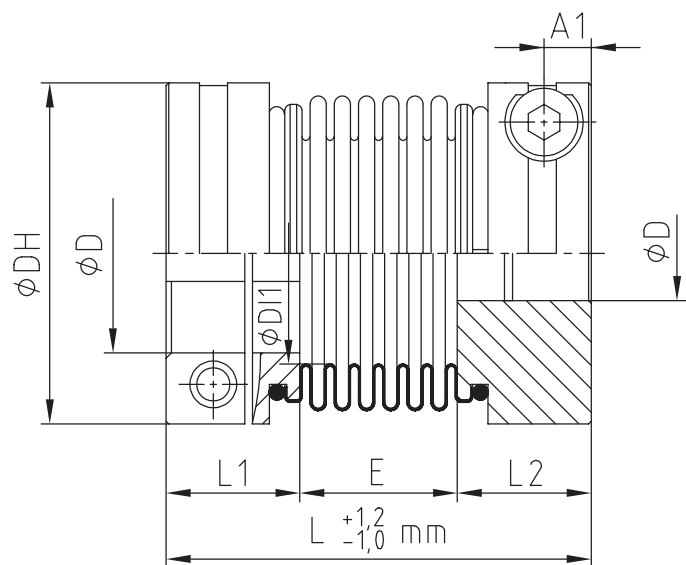

ROTEX® GS

Backlash-free  
servo couplings

ROTEX® GS HP

**Other types:**  
Type for FANUC motors

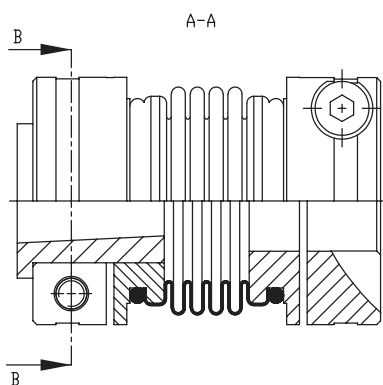

TOOLFLEX®

## Types of hubs

Type 2.5



Clamping hub double slot without feather keyway

Type 2.6



Clamping hub double slot with feather keyway

RADEX®-NC

# TOOLFLEX® PI

## Metal bellow-type couplings

### Axial plug-in

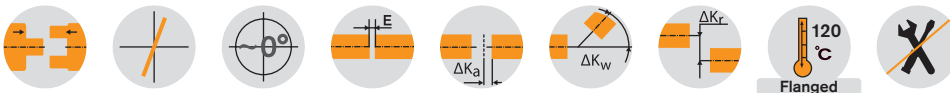
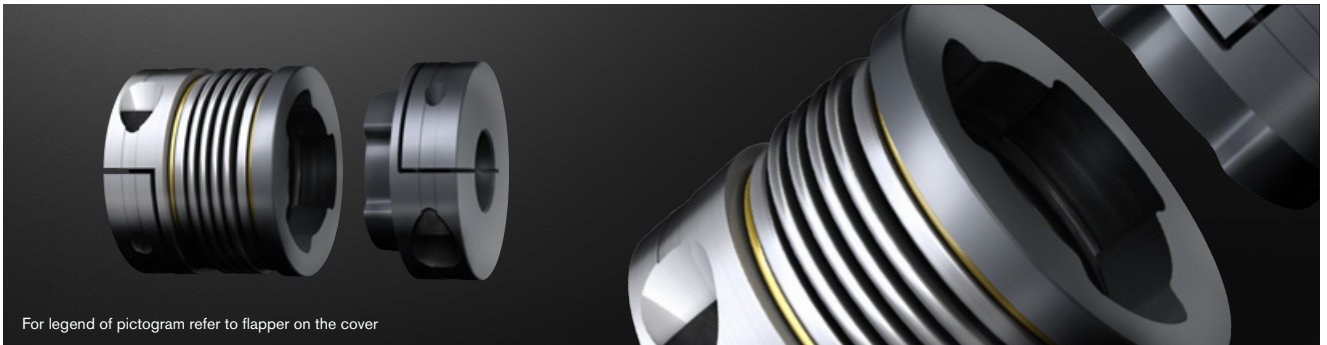

TOOLFLEX® Type S-PI - Hub material aluminium/bellow material stainless steel																
Size	Type	Dimensions [mm]										Clamping screws DIN EN ISO 4762				
		General														
		min. D, D1	max. D	max. D1	L <sup>1)</sup>	L1	L2	E	DH	HB = prestress	M	DK	K	A1, A2	T <sub>A</sub> [Nm]	
20	S	8	20	20	67.0	21.5	33.5	12.0	40	0.5 - 1	M 5	43.5	14.5	6	6	
30	S	10	30	28	73.5	23.0	33.5	17.0	55	0.5 - 1	M 6	58.0	19.0	7	10	
38	S	12	38	32	87.5	25.5	44.0	18.0	65	0.5 - 1.5	M 8	72.6	25.0	9	25	
42	S	14	42	35	93.0	30	39.0	21.0	70	0.5 - 1.5	M 8	76.1	25.0	9	25	
45	S	14	45	42	96.0	32.0	41.5	22.5	83	0.5 - 1.5	M 10	89.0	30.0	11	49	
55 <sup>4)</sup>	S	20	55	55	130.1	40	58.5	31.5	100	0.5 - 1.5	M 12	106.0	37	14	120	

Technical data of TOOLFLEX® S-PI										
Size	Type	Torque of bellow T <sub>KN</sub> <sup>2)</sup> [Nm]	Max. speed [rpm]	Moment of inertia <sup>3)</sup> [x10 <sup>6</sup> kgm <sup>2</sup> ]	Torsion spring stiffness C <sub>T</sub> [Nm/rad]	Axial stiffness C <sub>a</sub> [N/mm]	Radial stiffness C <sub>r</sub> [N/mm]	Perm. displacements		Weight <sup>4)</sup> [kg]
								Radial [mm]	Angular [degree]	
20	S	15	11950	37	6600	63	189	0.15	1.0	0.15
30	S	35	8700	140	11500	97	233	0.20	1.5	0.29
38	S	65	7350	329	21500	108	318	0.20	1.5	0.50
42	S	95	6820	396	31500	120	499	0.20	1.5	0.49
45	S	170	5750	1031	55000	132	738	0.25	1.5	0.93
55 <sup>4)</sup>	S	340	4800	6150	144100	160	894	0.25	1.5	3.80

TOOLFLEX® Type M-PI - Hub material aluminium/bellow material stainless steel																
Size	Type	Dimensions [mm]										Clamping screws DIN EN ISO 4762				
		General														
		min. D, D1	max. D	max. D1	L <sup>1)</sup>	L1	L2	E	DH	H = prestress	M	DK	K	A1, A2	T <sub>A</sub> [Nm]	
20	M	8	20	20	74.0	21.5	33.5	19.0	40	0.5 - 1	M 5	43.5	14.5	6	6	
30	M	10	30	28	82.5	23.0	33.5	26.0	55	0.5 - 1	M 6	58.0	19.0	7	10	
38	M	12	38	32	99.5	25.5	44.0	30.0	65	0.5 - 1.5	M 8	72.6	25.0	9	25	
42	M	14	42	35	104.0	30	39.0	32.0	70	0.5 - 1.5	M 8	76.1	25.0	9	25	
45	M	14	45	42	112.5	32.0	41.5	39.0	83	0.5 - 1.5	M 10	89.0	30.0	11	49	
55 <sup>4)</sup>	M	20	55	55	143.6	40	58.5	45	100	0.5 - 1.5	M 12	106.0	37	14	120	

Technical data of TOOLFLEX® M-PI										
Size	Type	Torque of bellow T <sub>KN</sub> <sup>2)</sup> [Nm]	Max. speed [rpm]	Moment of inertia <sup>3)</sup> [x10 <sup>6</sup> kgm <sup>2</sup> ]	Torsion spring stiffness C <sub>T</sub> [Nm/rad]	Axial stiffness C <sub>a</sub> [N/mm]	Radial stiffness C <sub>r</sub> [N/mm]	Perm. displacements		Weight <sup>4)</sup> [kg]
								Radial [mm]	Angular [degree]	
20	M	15	11950	38	4900	42	126	0.20	1.5	0.16
30	M	35	8700	145	10200	65	155	0.25	2.0	0.31
38	M	65	7350	346	15100	72	212	0.25	2.0	0.52
42	M	95	6820	427	22000	80	333	0.25	2.0	0.52
45	M	170	5750	1127	41000	88	492	0.30	2.0	1.00
55 <sup>4)</sup>	M	340	4800	6270	96100	107	598	0.30	2.0	3.90

<sup>1)</sup> When plugged in  
<sup>2)</sup> For selections see page 22 et seqq.  
<sup>3)</sup> Figures refer to the complete coupling with max. bore.  
<sup>4)</sup> Hub made of steel welded with bellow.

Review of shaft-hub-connection: Friction torques T <sub>R</sub> [Nm] for hub type 2.5																				
Size	Ø8	Ø9	Ø10	Ø11	Ø12	Ø14	Ø15	Ø16	Ø18	Ø19	Ø20	Ø24	Ø25	Ø28	Ø30	Ø32	Ø35	Ø38	Ø40	Ø42
20	13.5	15.0	16.5	18.0	19.3	22.1	23.5	24.8	27.4	28.7	30.0									
30				26	28	32	34	36	40	42	43	51	53	58	61					
38						63	67	71	79	82	86	101	105	115	122	129	139	148		
42						63	67	71	79	83	87	102	106	117	124	130	141	150	157	163
45											136	160	166	183	194	206	222	238	248	259
55 <sup>4)</sup>												341	354	391	416	440	475	510	533	556

Ordering example:	TOOLFLEX® 30 S-PI	D - Ø22	D1 - Ø18
	Size and type of coupling	Finish bore	Finish bore

TOOLFLEX® S-PI

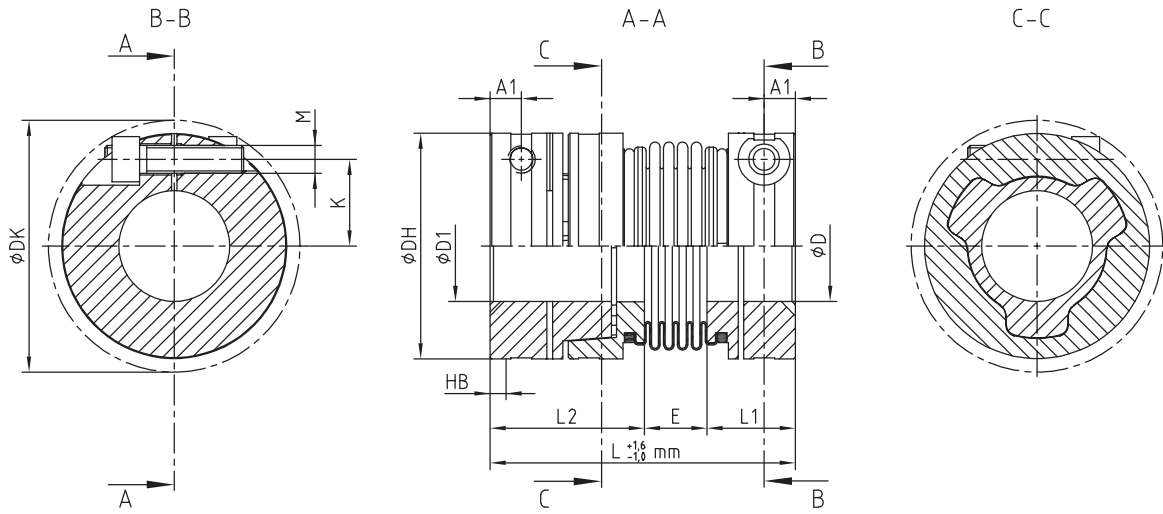

TOOLFLEX® M-PI

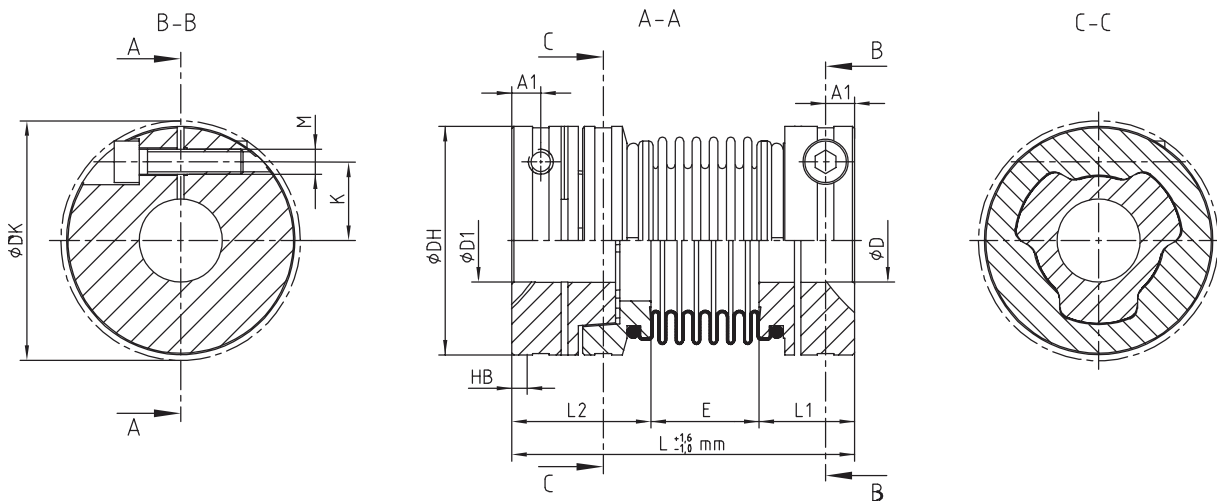

ROTEX® GS

Backlash-free  
servo couplings

ROTEX® GS HP

TOOLFLEX®

RADEX®-NC

# TOOLFLEX® S-H / M-H

## Metal bellow-type couplings

### Half shell clamping hubs

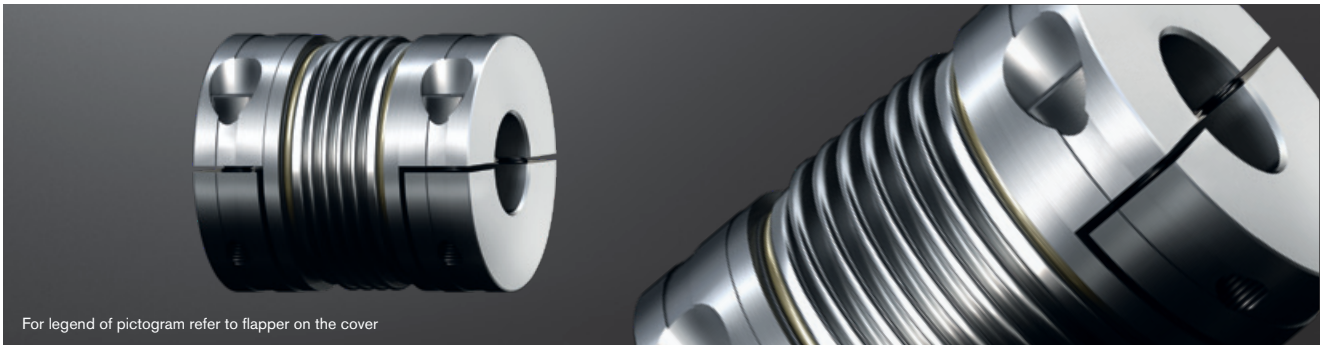

For legend of pictogram refer to flapper on the cover

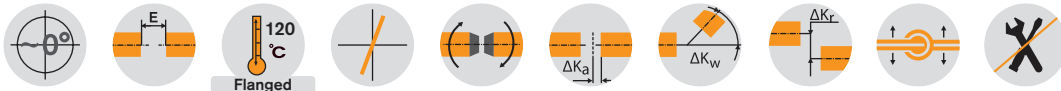

TOOLFLEX® type S-H / half shell clamping hubs - Hub material aluminium/bellow material stainless steel														
Size	Finish bore D		Dimensions [mm]											
	min.	max.	General								Clamping screws DIN EN ISO 4762			
			L	L1, L2	E	DH	DK	DBSE	A1	X1, X2	K	M	T <sub>A</sub> [Nm]	
20	8	20	51	19.5	12.0	40	41.2	26.0	5.5	12.5	14.5	M 4	5.0	
30	10	30	68	25.5	17.0	55	57.7	34.0	7.5	17.0	19.0	M 6	15.0	
38	12	38	78	30.0	18.0	65	72.6	36.0	9.5	21.0	25.0	M 8	40.0	
45	14	45	94.5	36.0	22.5	83	88.8	46.5	11.0	24.0	30.0	M 10	70.0	

Technical data of TOOLFLEX® S-H											
Size	Bel-low-hub-connection	Torque of bellow T <sub>KN</sub> <sup>1)</sup> [Nm]	Max. speed [rpm]	Moment of inertia <sup>2)</sup> [x10 <sup>-6</sup> kgm <sup>2</sup> ]	Torsion spring stiffness C <sub>T</sub> [Nm/rad]	Axial stiffness C <sub>a</sub> [N/mm]	Radial stiffness C <sub>r</sub> [N/mm]	Perm. displacements			Weight <sup>2)</sup> [kg]
								Axial [mm]	Radial [mm]	Angular [degree]	
20	Flanged	15	9550	28	9600	63	189	±0.4	0.15	1.0	0.110
30		35	6950	132	17800	97	233	±0.5	0.20	1.5	0.285
38		65	5850	292	37400	108	318	±0.6	0.20	1.5	0.422
45		170	4750	1003	95800	132	738	±0.9	0.20	1.5	0.897

TOOLFLEX® type M-H / half shell clamping hubs - Hub material aluminium/bellow material stainless steel														
Size	Finish bore D		Dimensions [mm]											
	min.	max.	General								Clamping screws DIN EN ISO 4762			
			L	L1, L2	E	DH	DK	DBSE	A1	X1, X2	K	M	T <sub>A</sub> [Nm]	
20	8	20	58	19.5	19.0	40	41.2	33.0	5.5	12.5	14.5	M 4	5.0	
30	10	30	77	25.5	26.0	55	57.7	43.0	7.5	17.0	19.0	M 6	15.0	
38	12	38	90	30.0	30.0	65	72.6	48.0	9.5	21.0	25.0	M 8	40.0	
45	14	45	111	36.0	39.0	83	88.8	63.0	11.0	24.0	30.0	M 10	70.0	

Technical data of TOOLFLEX® M-H											
Size	Bel-low-hub-connection	Torque of bellow T <sub>KN</sub> <sup>1)</sup> [Nm]	Max. speed [rpm]	Moment of inertia <sup>2)</sup> [x10 <sup>-6</sup> kgm <sup>2</sup> ]	Torsion spring stiffness C <sub>T</sub> [Nm/rad]	Axial stiffness C <sub>a</sub> [N/mm]	Radial stiffness C <sub>r</sub> [N/mm]	Perm. displacements			Weight <sup>2)</sup> [kg]
								Axial [mm]	Radial [mm]	Angular [degree]	
20	Flanged	15	9550	29	6600	42	126	±0.6	0.20	1.5	0.115
30		35	6950	138	14800	65	155	±0.8	0.25	2.0	0.304
38		65	5850	310	24900	72	212	±0.8	0.25	2.0	0.445
45		170	4750	1069	64000	88	492	±1.0	0.25	2.0	0.947

<sup>1)</sup> For selections see page 22 et seqq.

<sup>2)</sup> Figures refer to the complete coupling with max. bore.

To make sure that the coupling can be assembled/disassembled radially, please observe the insertion dimension X1/X2 of the shafts.

Review of shaft-hub-connection: Friction torques T <sub>R</sub> [Nm] for hub type 7.8																					
Size	Ø8	Ø9	Ø10	Ø11	Ø12	Ø14	Ø15	Ø16	Ø18	Ø19	Ø20	Ø24	Ø25	Ø28	Ø30	Ø32	Ø35	Ø38	Ø40	Ø42	Ø45
20	20	23	25	28	30	35	38	40	45	48	50										
30			51	56	61	71	76	81	92	97	102	122	127	143							
38					120	140	150	160	180	190	200	240	250	280	300	320	350	380			
45						197	211	226	254	268	282	338	352	395	423	451	493	536	564	592	634

Ordering example:	TOOLFLEX® 30 S-H		7.8 - Ø25				7.9 - Ø30														
	Size and type of coupling		Hub type		Finish bore		Hub type		Finish bore												

TOOLFLEX® S-H

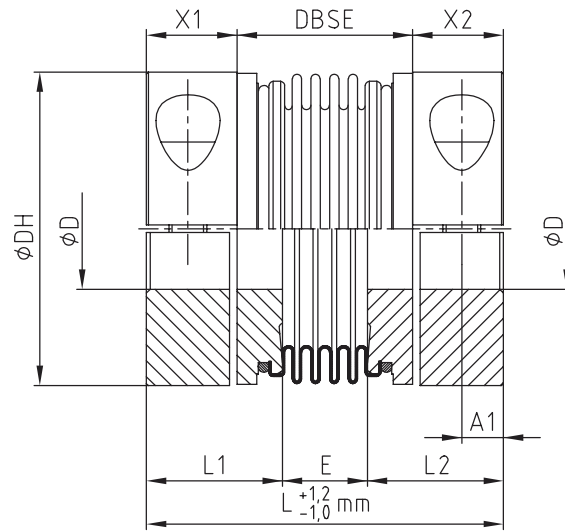
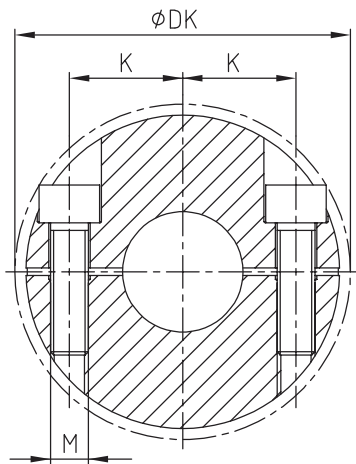

TOOLFLEX® M-H

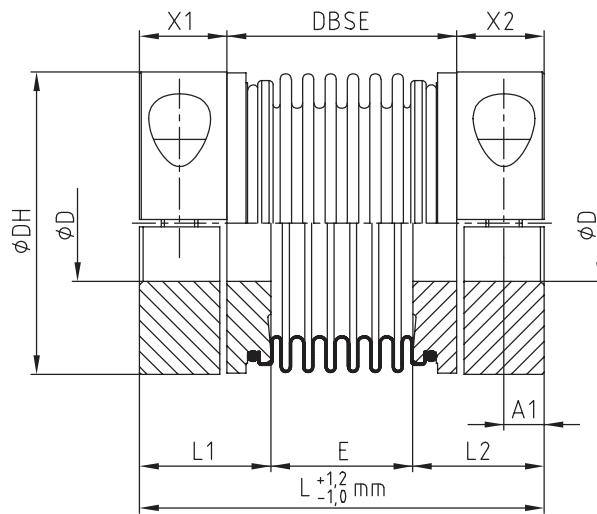
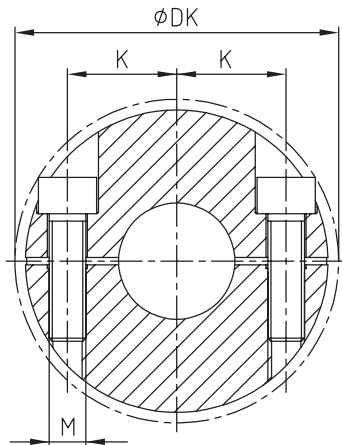

ROTEX® GS

Backlash-free  
servo couplings

ROTEX® GS HP

TOOLFLEX®

Types of hubs

Type 7.8



clamping hub type H without feather keyway for single-cardanic connection

Type 7.9



clamping hub type H with feather keyway for single-cardanic connection (on request)

RADEX®-NC

# TOOLFLEX® ZR

## Metal bellow-type couplings

### Intermediate shaft coupling with bonded aluminium pipe

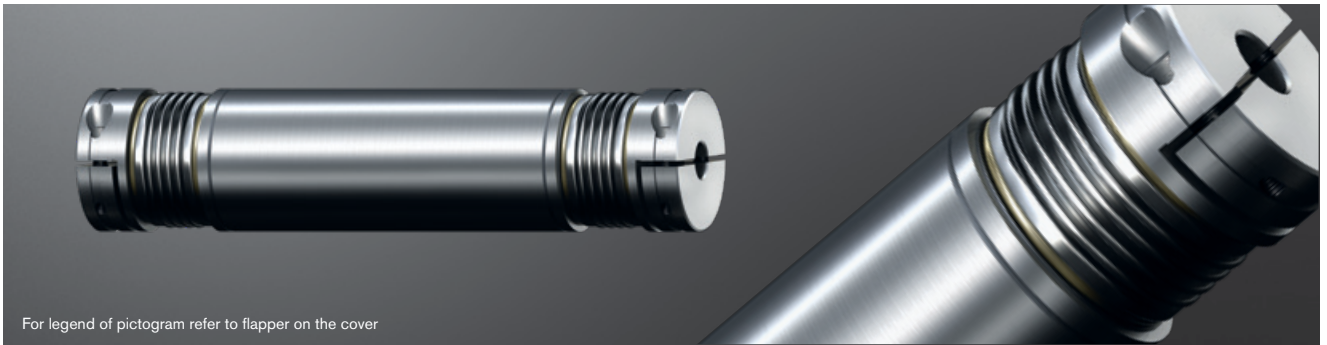

For legend of pictogram refer to flapper on the cover

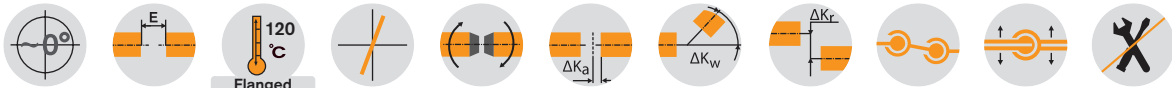

TOOLFLEX® type ZR / half shell clamping hubs - Hub material aluminium/bellow material stainless steel																
Size	Finish bore D		Dimensions [mm]												Clamping screws DIN EN ISO 4762	
	min.	max.	DH	LH	X1	General				DR	DK	A1	K	M	T <sub>A</sub> [Nm]	
						DBSE		L = DBSE + 2 • X1								
						min.	max.	min.	max.							
20	8	20	40	40	12.5	80	2975	105	3000	40	41.2	5.5	14.5	M 4	5	
30	10	28	55	58.5	17.0	114	3466	148	3500	50	58.0	7.5	19	M 6	15	
38	12	38	65	61	21.0	129	3958	171	4000	60	72.6	9.5	25	M 8	40	
45	14	45	83	78.5	25.0	149	3950	199	4000	80	89.0	11.0	30	M 10	70	

Technical data of TOOLFLEX® ZR				
Size	Torque of bellow T <sub>KN</sub> <sup>1)</sup> [Nm]	Moment of inertia [10 <sup>-3</sup> kgm <sup>2</sup> ]		Static torsion spring stiffness [Nm/rad]
		ZR hub <sup>2)</sup>	Pipe/meter	
20	15	0.024378	0.329	3245
30	35	0.121256	0.673	6630
38	65	0.253162	1.199	11,815
45	170	0.961451	4.560	44,930

<sup>1)</sup> For selections see page 22 et seqq.

<sup>2)</sup> Figures refer to the complete coupling with max. bore.

<sup>3)</sup> Torsion spring stiffness with a length of 1 m of intermediate pipe with  $L_{\text{pipe}} = L - 2 \cdot LH$

With inquiries and orders please specify the shaft distance dimension DBSE along with the maximum speed to review the critical bending speed.

Straightness/concentricity of pipes according to DIN EN 755-1.

Review of shaft-hub-connection: Friction torques T <sub>R</sub> [Nm] for hub type 7.5																						
Size	Ø8	Ø9	Ø10	Ø11	Ø12	Ø14	Ø15	Ø16	Ø18	Ø19	Ø20	Ø24	Ø25	Ø28	Ø30	Ø32	Ø35	Ø38	Ø40	Ø42	Ø45	
20	20	23	25	28	30	35	38	40	45	48	50											
30			51	56	61	71	76	81	92	97	102	122	127	143								
38					120	140	150	160	180	190	200	240	250	280	300	320	350	380				
45						197	211	226	254	268	282	338	352	395	423	451	493	536	564	592	634	

Ordering example:	TOOLFLEX® 30	ZR	1200 mm	7.5 - Ø24		7.6 - Ø24	
	Size and type of coupling	Type	Shaft distance dimension DBSE	Hub type	Finish bore	Hub type	Finish bore

TOOLFLEX® ZR

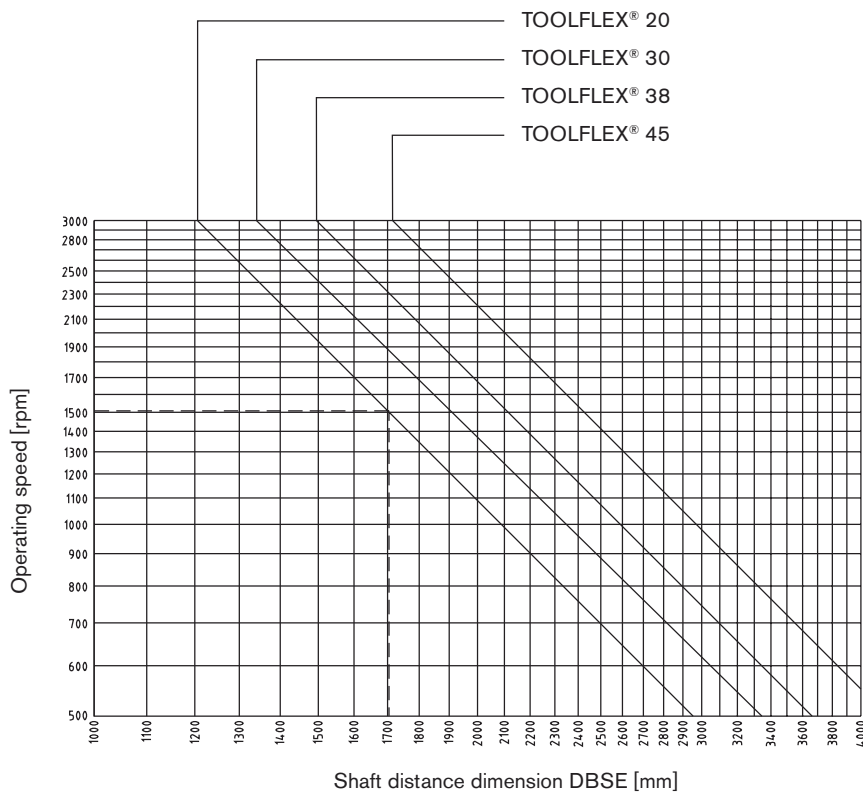
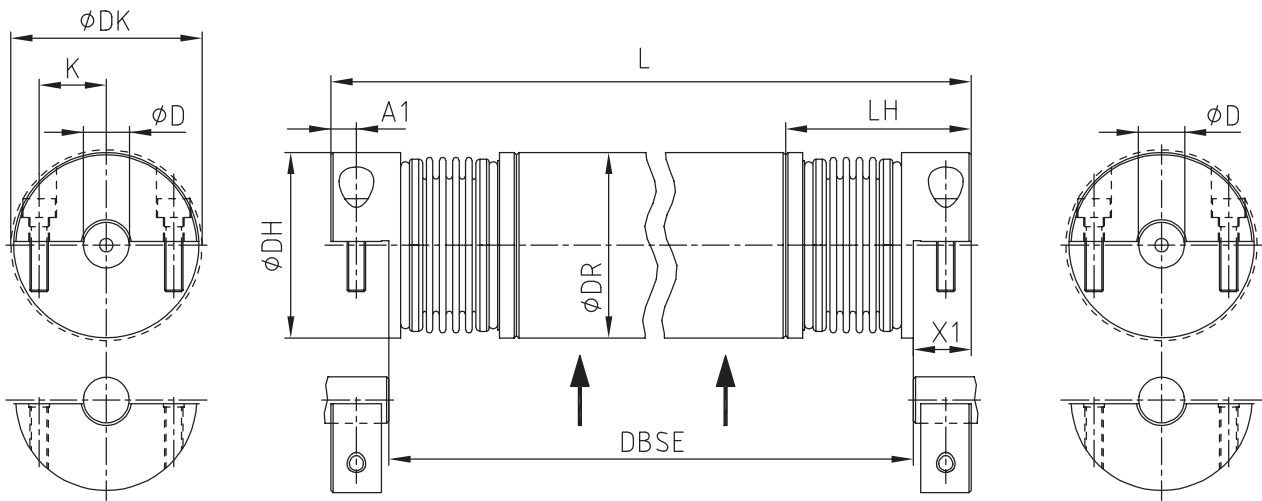

ROTEF® GS

Backlash-free  
servo couplings

ROTEF® GS HP

TOOLFLEX®

RADEX®-NC

Types of hubs

Type 7.5



Clamping hub type DH without feather keyway for double-cardanic connection

Type 7.6



Clamping hub type DH with feather keyway for double-cardanic connection (on request)

# RADEX®-NC

## Servo laminae couplings

### Technical description

RADEX®-NC is a line specifically developed for servo technology. With this coupling a set of torsionally stiff steel laminae that are soft in bending ensure reliable compensation for axial, angular and radial shaft displacements. As an all-metal coupling - the laminae are made of stainless steel - RADEX®-NC can even be used with high temperatures (up to 200 °C) and under aggressive ambient conditions. RADEX®-NC is manufactured in 10 sizes from size 5 to 75 for max. torques up to 4800 Nm. In addition to the two different types (EK = single-cardanic and DK = double-cardanic) it is available in five different hub types.



A typical application of RADEX®-NC are backlash-free worm gear pairs with low gear ratios. For reason of the gear ratio of the gearbox the stiffness of the coupling must be converted from the drive side into the driven side. Here the gear ratio itself has a decisive effect because it is included in the calculation by square. This converted stiffness is added in line with the gearbox stiffness in order to obtain the total stiffness. In case of gear ratios that are smaller than  $i = 8$  we recommend to use RADEX®-NC due to the loss of stiffness of the total system arising with the use of flexible couplings.

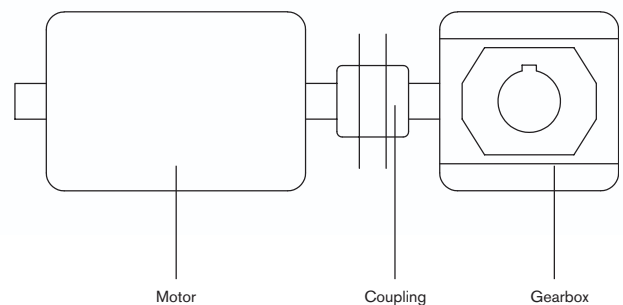

### Use in potentially explosive atmospheres

RADEX®-NC couplings are suitable for power transmission in drives in potentially explosive atmospheres. The couplings are assessed and approved as units of category 2G/2D according to EU directive 2014/34/EU and thus suitable for the use in potentially explosive atmospheres of zone 1, 2, 21 and 22. Please read through our information included in the respective type examination certificate and the operating and assembly instructions at [www.ktr.com](http://www.ktr.com).

Selection:

If used in potentially explosive atmospheres, the clamping hubs without feather keyway only for use in category 3 (with feather keyway for cat. 2) must be selected in that there is a minimum safety factor of  $s = 2$  between the peak torque of the unit (including all operating parameters) and the nominal torque and frictional torque of engagement of the coupling.



# RADEX®-NC DK and EK Servo laminae couplings

## Laminae sets

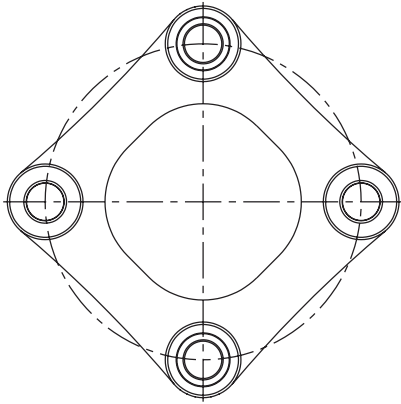

Size 5 to 26  
(lamina with 4 holes)

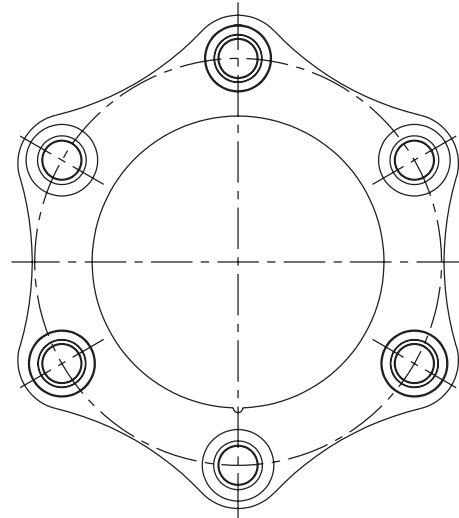

Size 36 to 75  
(lamina with 6 holes)

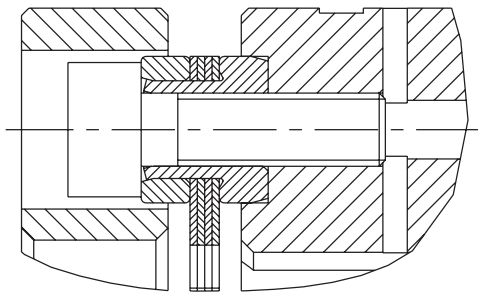

Size 5 to 10  
(cylindrical sleeve)

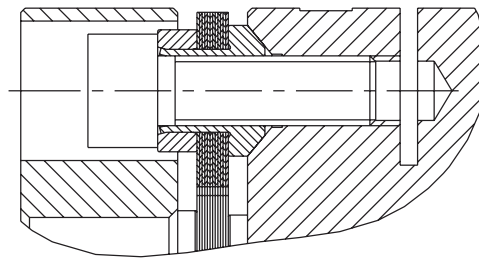

Size 16 to 75  
(taper sleeve)

## Types of hubs



**Type 2.5 clamping hub**  
double slotted, without feather keyway  
Frictionally engaged, backlash-free shaft-hub-connection.  
Transmittable torques depending on bore diameter.



**Type 2.6 clamping hub**  
double slotted, with feather keyway  
Positive-locking power transmission with additional friction fit. The friction fit avoids resp. reduces reverse backlash. Surface pressure of the keyway connection is reduced.



**Type 6.5 clamping ring hub**  
Integrated frictionally engaged shaft-hub-connection for the transmission of higher torques. Suitable for high speeds.



**Type 7.5 clamping hub type DH**  
without feather keyway for double-cardanic connection  
Frictionally engaged, backlash-free shaft-hub-connection for radial assembly of coupling. Transmittable torques depending on bore diameter.

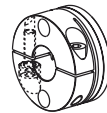

**Type 3.5 clamping hub**  
triple slotted, without feather keyway  
Frictionally engaged, backlash-free shaft-hub-connection, good properties of concentric running and reduced imbalance. Transmittable torques depending on bore diameter. Type 3.5 standard from size 43

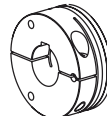

**Type 3.6 clamping hub**  
triple slotted, with feather keyway  
Positive-locking power transmission with additional friction fit. The friction fit avoids resp. reduces reverse backlash. Surface pressure of the keyway connection is reduced. Type 3.6 standard from size 43



**Type 7.6 clamping hub type DH**  
with feather keyway for double-cardanic connection  
Positive-locking, backlash-free power transmission with additional friction fit for radial assembly of coupling. The friction fit avoids resp. reduces reverse backlash. Surface pressure of the keyway connection is reduced.

ROTEX® GS

Backlash-free  
servo couplings

ROTEX® GS HP

TOOLFLEX®

RADEX®-NC

# RADEX®-NC DK and EK Servo laminae couplings

## Double- and single-cardanic types



For legend of pictogram refer to flapper on the cover

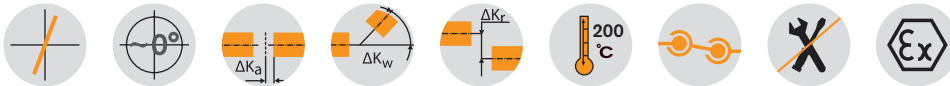

### Hub type 2.5/2.6

#### Type DK

#### Type EK

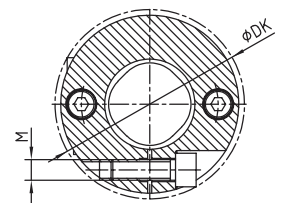
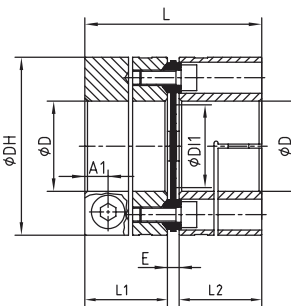
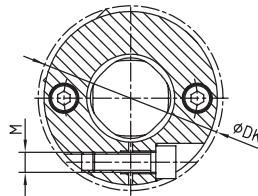
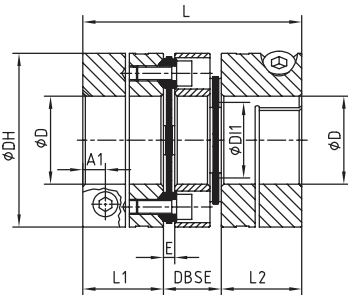

### RADEX®-NC Types DK and EK - Hub and spacer material aluminium/laminas made of stainless steel

Size	Dimensions [mm]										Clamping screws DIN EN ISO 4762		Mass moment of inertia [kgm <sup>2</sup> ]	
	D <sub>max.</sub>	DH	DK	Type DK		Type EK	D11	E	A1	M	T <sub>A</sub> [Nm]	Type DK	Type EK	
				L1, L2	L	DBSE						L	Type DK	Type EK
5	12	26	26	12	34	10	26.5	12	2.5	3.5	M 2.5	0.8	0.000004	0.000003
10	15	35	35	16	44	12	35	14.5	3	5	M 4	3	0.000016	0.000012
16	20	46	49	22	58	14	47	19.5	3	6.8	M 6	10	0.000063	0.00005
21	30	58	59	25	69	19	53.5	24	3.5	6.8	M 6	10	0.00018	0.00014
26	38	69	73	32	88	24	69	30	5	9	M 8	25	0.00046	0.00036
36	45	84	87	35	93.6	23.6	74.8	48	4.8	10.5	M 10	49	0.0011	0.00091

### Technical data

Size	T <sub>KN</sub> <sup>1)</sup> [Nm]	T <sub>K max</sub> <sup>1)</sup> [Nm]	Max. speed [rpm]	Torsion spring stiffness [Nm/rad]			Laminae type	Displacements of type DK			Displacements of type EK		
				Type DK		Type EK		Radial [mm]	Axial [mm]	Angular per lamina [degree]	Radial [mm]	Axial [mm]	Angular per lamina [degree]
				Type EK	Type DK								
5	2.5	5	18,300	2,400	1,200	4 holes	0.13	± 0.4	1	-	± 0.2	1	
10	7.5	15	13,600	5,600	2,800	4 holes	0.16	± 0.8	1	-	± 0.4	1	
16	35	53	10,500	20,000	10,000	4 holes	0.19	± 1.0	1	-	± 0.5	1	
21	70	105	8,500	40,000	20,000	4 holes	0.27	± 1.2	1	-	± 0.6	1	
26	120	180	7,000	84,000	42,000	4 holes	0.33	± 1.6	1	-	± 0.8	1	
36	340	510	5,700	280,000	140,000	6 holes	0.32	± 2.0	1	-	± 1.0	1	

<sup>1)</sup> For selection see page 22 et seqq.

### Review of shaft-hub-connection: Friction torques T<sub>R</sub> [Nm] for hub type 2.5

Size	Pilot bored	Ø3	Ø5	Ø8	Ø10	Ø12	Ø14	Ø15	Ø16	Ø19	Ø20	Ø22	Ø24	Ø25	Ø28	Ø30	Ø32	Ø35	Ø38	Ø40	Ø42	Ø45
5	2.5	1.1	1.8	2.8	3.4	4																
10	4.5		5	7.7	9.5	11.1	12.7	13.5														
16	5.5				23	27	31	33	35	41	43											
21	7.5					28	32	34	36	42	44	48	52	54	59	63						
26	9.5							66	70	81	85	92	100	103	114	121	127	137	147			
36	11.5									129	135	147	159	165	182	194	199	221	237	247	258	273

Ordering  
example:

RADEX®-NC 21	DK	2.5 - Ø20		2.5 - Ø25	
Coupling size	Type	Hub type	Finish bore	Hub type	Finish bore

# RADEX®-NC DK and EK Servo laminae couplings

## Double- and single-cardanic types

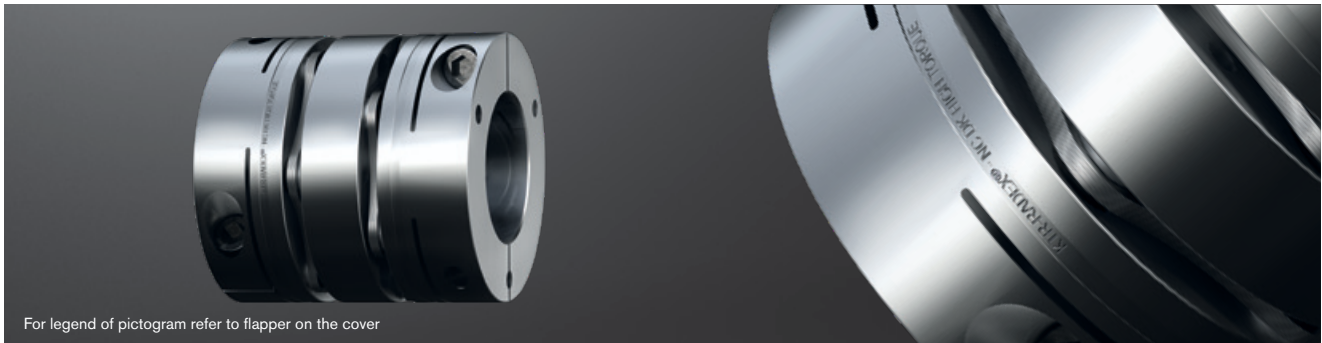

For legend of pictogram refer to flapper on the cover

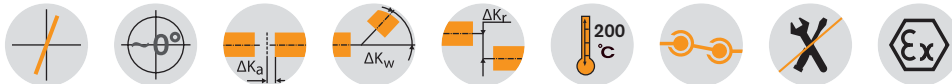

### Hub type 3.5/3.6

#### Type DK

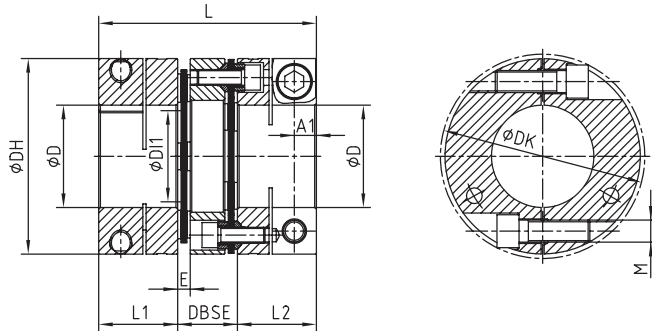

#### Type EK

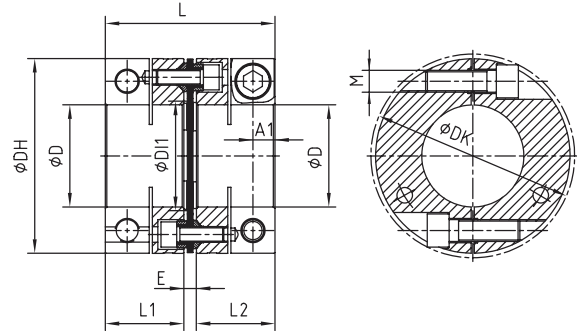

ROTEX® GS

Backlash-free  
servo couplings

ROTEX® GS HP

TOOLFLEX®

RADEX®-NC

### RADEX®-NC Types DK and EK - Hub and spacer material aluminium up to size 61, steel with size 75 / laminae made of stainless steel

Size	Dimensions [mm]										Clamping screws DIN EN ISO 4762		Mass moment of inertia [kgm <sup>2</sup> ]	
	D <sub>max.</sub>	DH	DK	Type DK		Type EK	DI1	E	A1	M	T <sub>A</sub> [Nm]	Type DK	Type EK	
				L1, L2	L							DBSE	L	Type DK
43	55	104	104	40.5	115	34	89	61	8	10.5	M 10	49	0.0033	0.0025
51	70	124	130	50	138	38	108	73	8	14	M 14	135	0.0082	0.006
61	80	144	148.5	54	150	42	118	88	10	16	M 16	210	0.016	0.012
75	90	170	181.1	70	189	49	152	104	12	21.5	M 20	610	0.099	0.077

### Technical data

Size	T <sub>KN</sub> <sup>1)</sup> [Nm]	T <sub>K max</sub> <sup>1)</sup> [Nm]	Max. speed [rpm]	Torsion spring stiffness [Nm/rad]		Laminae type	Displacements of type DK			Displacements of type EK		
				Type EK	Type DK		Radial [mm]	Axial [mm]	Angular per lamina [degree]	Radial [mm]	Axial [mm]	Angular per lamina [degree]
43	600	900	8,100	510,000	255,000	6 holes	0.45	± 2.20	1	—	± 1.10	1
51	1,300	1,950	6,700	920,000	460,000	6 holes	0.52	± 2.50	1	—	± 1.25	1
61	2,000	3,000	6,100	1,500,000	750,000	6 holes	0.56	± 2.60	1	—	± 1.30	1
75	3,200	4,800	5,100	2,100,000	1,050,000	6 holes	0.64	± 2.90	1	—	± 1.45	1

<sup>1)</sup> For selection see page 22 et seqq.

### Review of shaft-hub-connection: Friction torques T<sub>R</sub> [Nm] for hub type 3.5

Size	Pilot bored	Ø24	Ø25	Ø28	Ø30	Ø32	Ø35	Ø38	Ø40	Ø42	Ø45	Ø48	Ø50	Ø55	Ø58	Ø60	Ø65	Ø70	Ø75	Ø80	Ø85	Ø90	
43	15.0	238	248	258	297	317	347	377	397	416	446	476	496	545									
51	28.0				594	633	693	752	792	831	891	950	990	1089	1148	1188	1286	1385					
61	30.0							1039	1093	1148	1230	1312	1367	1503	1585	1640	1777	1913	2050	2187			
75	35												3129	3192	3630	3755	4068	4381	4694	5006	5319	5632	

Ordering  
example:

RADEX®-NC 43	DK	3.5 - Ø25		3.5 - Ø35	
Coupling size	Type	Hub type	Finish bore	Hub type	Finish bore

# RADEX®-NC DK and EK with clamping ring hubs

## Servo laminae couplings

### Double- and single-cardanic types



For legend of pictogram refer to flapper on the cover

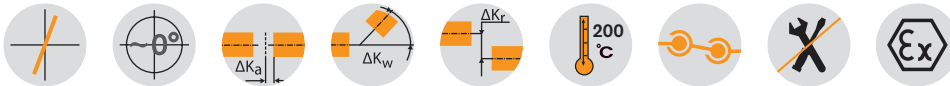

#### RADEX®-NC Types DK and EK - Hub and spacer material aluminium/laminas made of stainless steel

Size	Dimensions [mm]										Clamping screws DIN EN ISO 4017			Mass moment of inertia [kgm <sup>2</sup> ]		
	D <sub>max</sub>	DH	L1, L2	L3	Type DK		Type EK		L6	DI1	E	M x LM	Z = number <sup>1)</sup>	T <sub>A</sub> [Nm]	Type DK	Type EK
					L	DBSE	L	Type DK							Type EK	
16	20	46	24	18	62	14	3.0	3.0	19.5	3	M5 x 20	4	6	0.000075	0.000063	
21	28	58	28	22	75	19	3.1	3.1	24	3.5	M6 x 25	4	10	0.000218	0.000177	
26	35	69	36	28	96	24	2.4	2.4	30	5	M5 x 30	8	6	0.000565	0.000467	
36	42	84	43	35	109.6	23.6	4.35	4.35	48	4.8	M8 x 40	6	25	0.001581	0.001294	
43	60	104	46	35	126	34	4.95	4.95	61	8	M8 x 40	6	25	0.004051	0.003250	
51	70	124	50	38	138	38	6.25	6.25	73	8	M10 x 45	6	49	0.008981	0.007096	
61	80	144	55	43	152	42	6.75	6.75	88	10	M12 x 50	6	85	0.024188	0.020678	

#### Technical data

Size	T <sub>KN</sub> <sup>2)</sup> [Nm]	T <sub>K</sub> max <sup>2)</sup> [Nm]	Max. speed [rpm]	Torsion spring stiffness [Nm/rad]		Laminae type	Displacements of type DK			Displacements of type EK		
				Type EK	Type DK		Radial [mm]	Axial [mm]	Angular per lamina [degree]	Radial [mm]	Axial [mm]	Angular per lamina [degree]
16	35	53	31,150	20,000	10,000	4 holes	0.19	± 1.00	1.00	—	± 0.50	1
21	70	105	24,700	40,000	20,000	4 holes	0.27	± 1.20	1.00	—	± 0.60	1
26	120	180	20,800	84,000	42,000	4 holes	0.33	± 1.60	1.00	—	± 0.80	1
36	340	510	17,100	280,000	140,000	6 holes	0.32	± 2.00	1.00	—	± 1.00	1
43	600	900	13,800	510,000	255,000	6 holes	0.45	± 2.20	1.00	—	± 1.10	1
51	1300	1950	11,600	920,000	460,000	6 holes	0.52	± 2.50	1.00	—	± 1.25	1
61	2000	3000	10,000	1,500,000	750,000	6 holes	0.56	± 2.60	1.00	—	± 1.30	1

<sup>1)</sup> per clamping ring hub

<sup>2)</sup> For selection see page 22 et seqq.

#### Review of shaft-hub-connection: Friction torques T<sub>R</sub> [Nm] for hub type 6.5

Size	Tolerance fit	Ø10	Ø12	Ø14	Ø15	Ø16	Ø19	Ø20	Ø24	Ø25	Ø28	Ø30	Ø32	Ø35	Ø38	Ø40	Ø42	Ø45	Ø48	Ø50	Ø55*	Ø60*	Ø65*	Ø70*	Ø75*	Ø80*
16	H7/h6	29	33	57	70	50	83	97																		
	H7/k6	34	42	64	76	62	96	109																		
21	H7/h6	27	45	75	91	79	125	145	127	144	201															
	H7/k6	36	56	83	99	93	139	157	169	187	245															
26	H7/h6				104	126	194	169	279	311	338	404	273	357												
	H7/k6				124	145	214	200	305	334	382	444	355	441												
36	H7/h6							241	395	438	521	616	523	664	647	741	841									
	H7/k6							284	430	471	558	646	640	779	778	875	974									
43	H7/h6										595	705	647	814	946	1073	980	1163	1360	1200	1072	1372				
	H7/k6										684	789	784	916	1096	1219	1144	1332	1534	1376	1370	1669				
51	H7/h6										750	818	1020	1085	1228	1166	1377	1605	1450	1607	2283	2255	2704			
	H7/k6										822	927	1117	1254	1392	1348	1568	1803	1652	1960	2387	2447	2842			
61	H7/h6													880	1074	1211	1264	1480	1597	1750	1911	2097	2542	2669	2718	3168
	H7/k6													951	1131	1258	1333	1534	1668	1810	2032	2239	2635	2785	2855	3252

\* From Ø55 tolerance G7/h6 or G7/m6

Ordering example:

RADEX®-NC 26	DK	6.5 - Ø24			6.5 - Ø35	
Coupling size	Type	Hub type	Finish bore	Hub type	Finish bore	

Hub type 6.5

Type DK

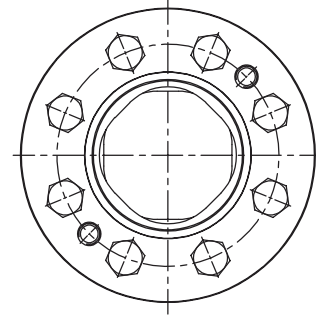
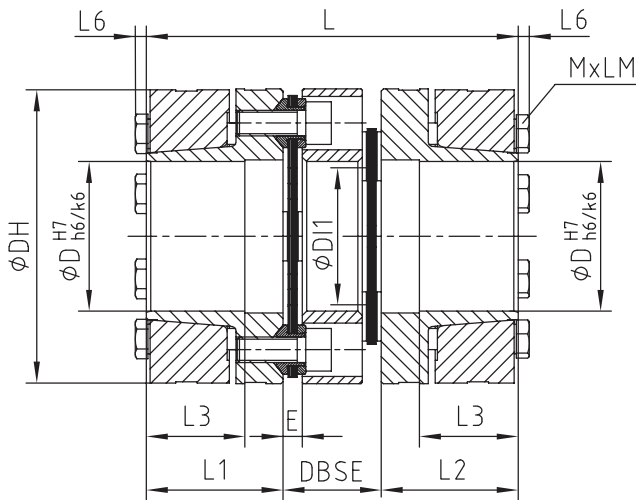

Type EK

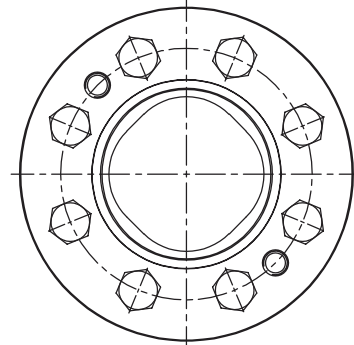
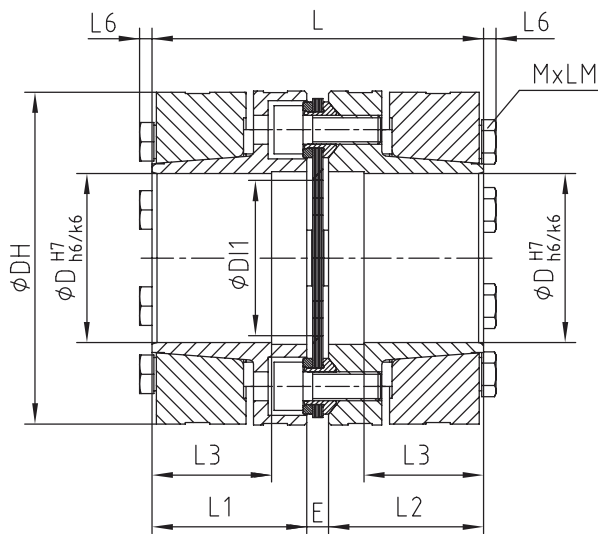

ROTEX® GS

Backlash-free  
servo couplings

ROTEX® GS HP

TOOLFLEX®

Types of hubs



Type 6.5  
Clamping ring hub

RADEX®-NC

# RADEX®-NC ZR

## Servo laminae couplings

### Double-cardanic type

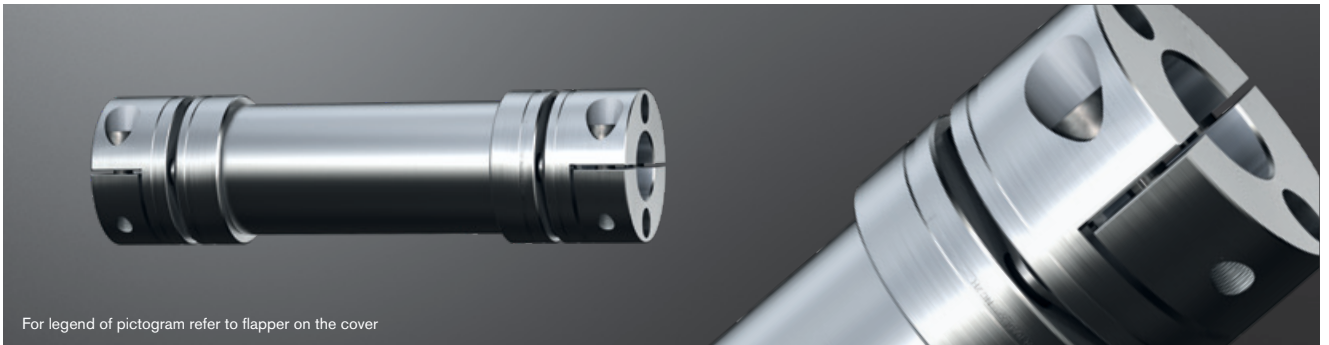

For legend of pictogram refer to flapper on the cover

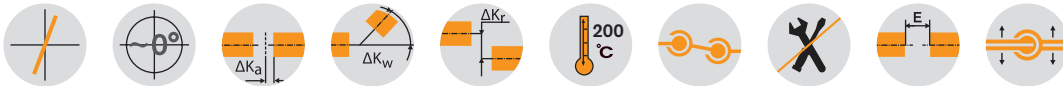

#### RADEX®-NC Type ZR - Hub and spacer material aluminium/laminas made of stainless steel

Size	Finish bore D		Dimensions [mm]											Clamping screws DIN EN ISO 4762	
	min.	max.	DH	L	X1	General		L = DBSE + 2 • X1		DR	DK	A1	K	M	T <sub>A</sub> [Nm]
						min.	max.	min.	max.						
16	6	20	46	42	17.0	75	2966	109	3000	40	48.9	8	16	M 6	15.0
21	8	30	58	47.5	17.0	92	3466	126	3500	50	59.2	8	20.5	M 6	15.0
26	10	35	69	59	21.5	124	3957	167	4000	60	72.6	9.5	25	M 8	40.0
36	12	45	84	62.3	26.5	114	3947	167	4000	80	86.8	12	30	M 10	70.0

#### Technical data of RADEX®-NC ZR

Size	TKN <sup>1)</sup> [Nm]	Moment of inertia [10 <sup>-3</sup> kgm <sup>2</sup> ]		Static torsion spring stiffness [Nm/rad]
		ZR hub <sup>2)</sup>	Pipe/meter	
16	35	0.049596	0.329	2449
21	70	0.138744	0.673	4980
26	120	0.348421	1.199	9220
36	340	0.869569	4.560	34014

<sup>1)</sup> For selections see page 22 et seqq.

<sup>2)</sup> Figures refer to the complete coupling with max. bore.

<sup>3)</sup> Torsion spring stiffness with a length of 1 m of intermediate pipe with  $L_{\text{pipe}} = L - 2 \cdot LH$

With inquiries and orders please specify the shaft distance dimension DBSE along with the maximum speed to review the critical bending speed.

Straightness/concentricity of pipes according to DIN EN 755-1.

#### Review of shaft-hub-connection: Friction torques T<sub>R</sub> [Nm] for hub type 7.5

Size	Ø8	Ø9	Ø10	Ø11	Ø12	Ø14	Ø15	Ø16	Ø18	Ø19	Ø20	Ø24	Ø25	Ø28	Ø30	Ø32	Ø35	Ø38	Ø40	Ø42	Ø45	
16			51	56	61	71	76	81	92	97	102											
21					61	71	76	81	92	97	102	122	127	143	153							
26							150	160	180	190	200	240	250	280	300							
36										268	282	338	352	395	423	451	493	536	564	592	634	

Ordering example:

RADEX®-NC 26	ZR	1200 mm	7.5 - Ø24	7.6 - Ø24
Coupling size	Type	Shaft distance dimension (DBSE)	Hub type	Finish bore
			Finish bore	Hub type
				Finish bore

## Components

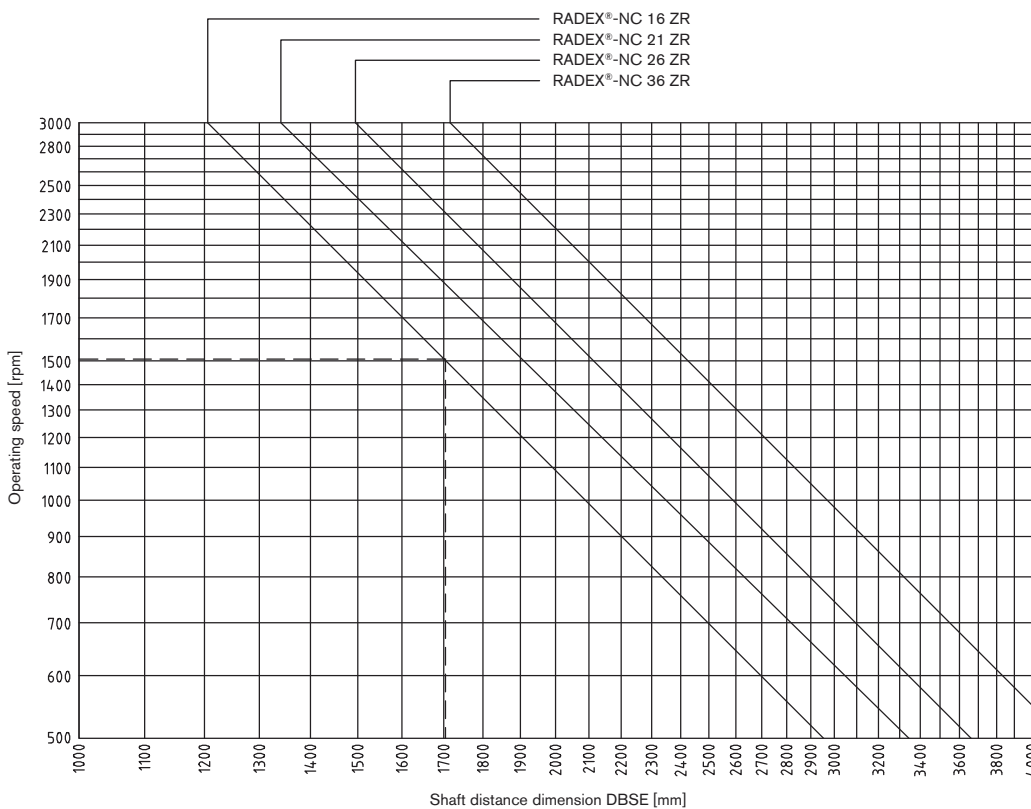
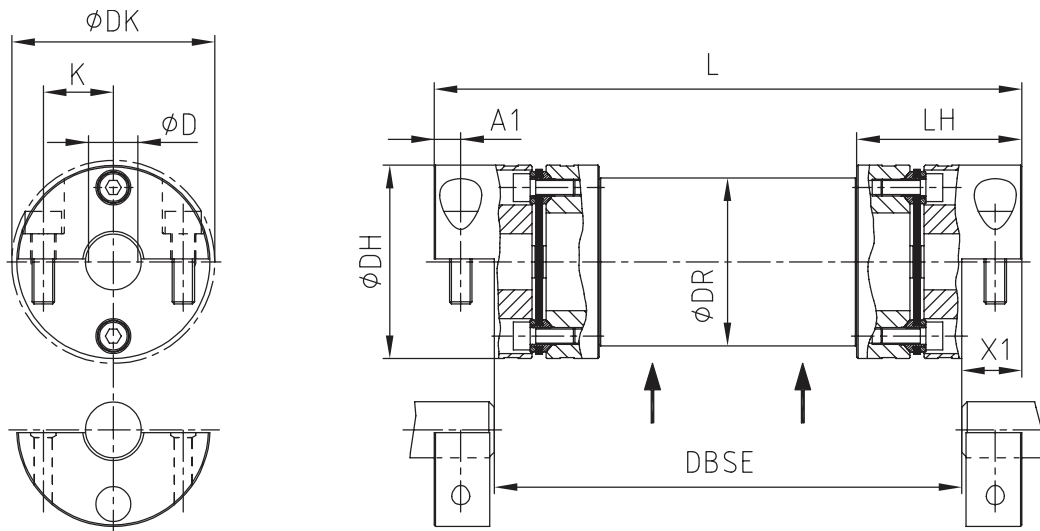

## Types of hubs

Type 7.5

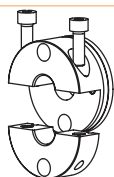

Clamping hub type DH without feather keyway for double-cardanic connection

Type 7.6

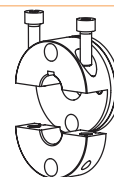

Clamping hub type DH with feather keyway for double-cardanic connection (on request)



# Steel laminae couplings

Types and operating description 172

---

## RADEX®-N

General information and hub types	174
Types and applications	175
Technical data	176
Standard types	178
Customised types	180
Corrosion-resistant type for large shaft distances	181
Standard series NANA 3 for pump drives in accordance with API 610	182

---

## RIGIFLEX®-N

General information and hub types	184
Technical data	185
Type A	187
Type A-J	188
Type A-H	189

RADEX®-N



RIGIFLEX®-N



# STEEL LAMINAE COUPLINGS

## TYPES AND OPERATING DESCRIPTION

### Properties of laminae couplings







		
Product	RADEX®-N	RIGIFLEX®-N
Type	Steel laminae coupling	
<b>Features</b>		
Torsionally stiff	●	●
Backlash-free	●	●
Maintenance-free	●	●
Compensating for misalignment	●	●
<b>Special features</b>		
Stock programme	Basic programme available from stock, customised solutions available	Basic programme available from stock, customised solutions available
Applications / core industries	Pumps, compressors, fans	Pumps, compressors, fans
API	610	610 & 671
<b>Performance data</b>		
Max. rated torque $T_{KN}$ [Nm]	280,000	280,000
Max. speed n [rpm]	20,000	23,000
Max. operating temperature T [°C]	280	280
<b>Standard materials</b>		
<b>Hubs</b>		
Steel (S355J2)	●	●
Q & T steel (C45N)	●	●
Q & T steel (42CrMo4V)		
Q & T steel (30CrNiMo8)		
<b>Spacers</b>		
Steel (S355J2)	●	●
Q & T steel (C45N)	●	●
Q & T steel (42CrMo4V)	with torsion shafts	
Q & T steel (30CrNiMo8)	with torsion shafts	
<b>Special materials (corrosion-resistant)</b>		
<b>Hubs</b>		
Steel (1.4305)	●	○
Steel (1.4404)	●	
<b>Spacers</b>		
Steel (1.4305)	●	
Steel (1.4404)	●	
Spacer made of Composite GRP (fibre glass)	●	○
Spacer made of Composite CFRP (carbon fibre)	●	
Surface coating	Painting, phosphating, zinc-coating and passivating, Geomet, Tenifer Q	Painting, phosphating, zinc-coating and passivating, Geomet, Tenifer Q

● ≈ Standard  
○ ≈ On request

# STEEL LAMINAE COUPLINGS

## TYPES AND OPERATING DESCRIPTION

### Product finder of laminae couplings

		
<b>Product</b>	<b>RADEX®-N</b>	<b>RIGIFLEX®-N</b>
<b>Type</b>	Steel laminae coupling	
<b>Geometries</b>		
Design	Single- and double-cardanic	double-cardanic
Max. shaft diameter [mm]	330	400
Radial assembly	●	●
<b>Certifications/type examinations</b>		
ATEX 	●	●
GOST R/ GOST TR 	●	●
DNV GL 	●	●
ABS 	●	●
LR 	●	●

● ≈ Standard

### Details on laminae couplings

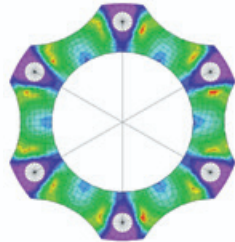
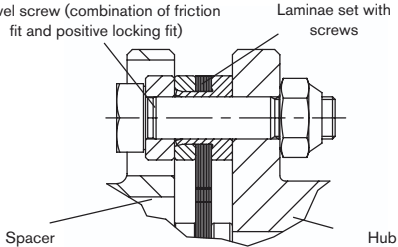
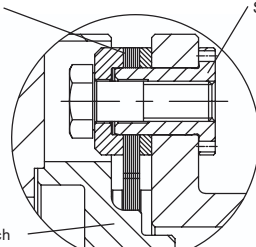
<p><b>Laminas - laminae shape optimized by FEM</b></p> <p>The steel laminae sets made of high-strength, stainless spring steel were developed based on FEM calculations. Considering the necessary options of displacement of the coupling, the optimum shape with regard to torque transmission and torsional stiffness was aimed at. The waisted shape of the steel laminas on the outside diameter resulted from this optimization calculation.</p>	
<p><b>RADEX®-N - laminae sets with dowel screws</b></p> <p>The core of the steel laminae coupling are the laminae sets and their connection to hubs resp. spacers. High-strength special dowel screws that are alternately screwed to hubs and spacer allow for a combination of friction fit and positive locking fit. Thus a high power density with simultaneous ease of displacement and low restoring forces is ensured.</p>	<p>Dowel screw (combination of friction fit and positive locking fit)</p> <p>Laminae set with screws</p>  <p>Spacer</p> <p>Hub</p>
<p><b>RIGIFLEX®-N - protecting the spacer</b></p> <p>Since our main idea with the development of RIGIFLEX®-N was to comply with the standards of API 610 and API 671, the spacer is secured by a safety catch, too. In case if the laminas break the spacer remains inside the coupling. In general the spacer is supplied along with laminae sets pre-assembled by the manufacturer. These are connected with the spacers resp. flanges fully free from backlash via positive-locking special pins.</p>	<p>Laminae set</p> <p>Special pins</p>  <p>Safety catch</p>

# RADEX®-N

## Steel laminae couplings

### General advice

#### Advice on assembly and operation

See our mounting instructions KTR standard 471 10 at [www.ktr.com](http://www.ktr.com). With the assembly it is important to make sure that the laminae sets are assembled free from distortion in axial direction. If the finish bore is machined by the customer, the concentricity and axial running tolerances have to be adhered to (see sketch).

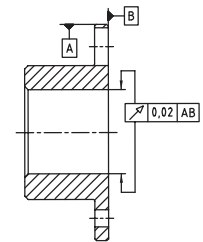

#### Installation

RADEX®-N couplings are designed for horizontal installation. With vertical installation the spacer might have to be supported (see sketch). Please consult with us.

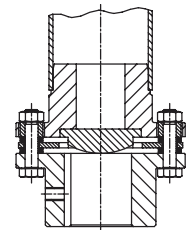

#### Delivery condition

RADEX®-N couplings are delivered as individual components (can be delivered assembled on request). The hubs can be supplied unbored or with finish bore and feather keyway or with a frictionally engaged shaft-hub-connection. The shaft-hub-connection needs to be inspected by the customer (consult with KTR, if necessary).



#### Balancing

On request of the customer the RADEX®-N couplings can be supplied with balancing. For standard applications this is not necessary due to accurate machining of the coupling. Please consult with us, if necessary.

#### Safety regulations

The coupling has to be dimensioned in that the permissible coupling load is not exceeded during any operating condition. For this purpose the actual loads have to be compared to the permissible coupling parameters. The customer has to protect rotating parts from accidental contact (Safety of Machinery DIN EN 292 chapter 2). Take precautions to make sure there is sufficient coupling protection in case of fracture of the coupling caused by overload.

### Types of hubs



#### Type 1.0 hub with feather keyway and setscrew

Positive-locking torque transmission, permissible torque depending on the permissible surface pressure. Not suitable for backlash-free torque transmission with heavily reversing operation.

#### Type 1.1 hub without feather keyway, with setscrew

Non-positive torque transmission for crimp connections and adhesive bonds. (No ATEX approval)

#### Type 1.2 hub without feather keyway, without setscrew

Non-positive torque transmission for crimp connections and adhesive bonds. (No ATEX approval)

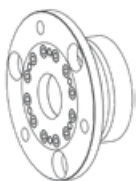

#### Type 6.0 clamping ring hub

Integrated frictionally engaged shaft-hub-connection for the transmission of higher torques. Clamping screws on laminae side. Transmittable torques depending on bore diameter. Suitable for high speeds.

#### Type 6.5 clamping ring hub

Integrated frictionally engaged shaft-hub-connection for the transmission of higher torques. Clamping screws from outside. Transmittable torques depending on bore diameter. Suitable for high speeds.



#### Type 2.5 clamping hub double slotted, without feather keyway

Frictionally engaged, backlash-free shaft-hub-connection. Transmittable torques depending on bore diameter. For ATEX category 3 only.

#### Type 2.6 clamping hub double slotted, with feather keyway

Positive-locking shaft-hub connection with additional friction fit. The friction fit prevents respectively reduces reverse backlash.

# RADEX®-N

## Steel laminae couplings

### Types and applications

Type NN (see page 178)

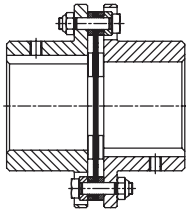

Type NANA 1/NANA 2 (see page 178)

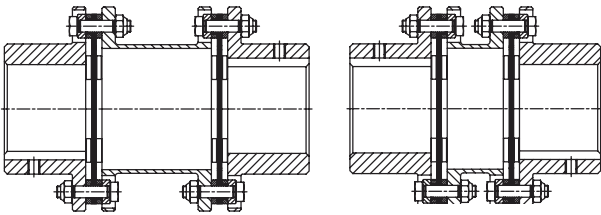

Type NANA 3 (see page 182)

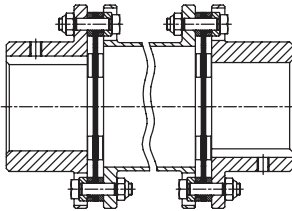

Type NANA 4 (see page 180)

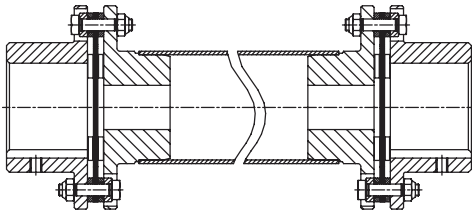

Type NNW (see page 180)

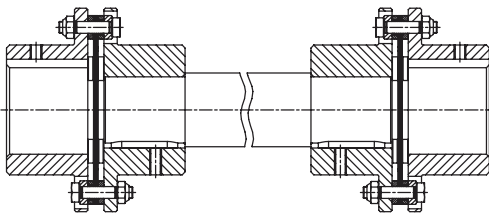

Type NNZ (see page 179)

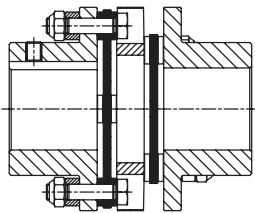

Type NENE (see page 179)

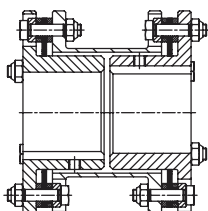

#### Features

- Single-cardanic type
- Only angular and axial displacement permissible
- High torsional rigidity
- Compact dimensions

#### Applications

- Mixers
- Agitators
- Immersion pumps
- Fans
- Applications with high radial load

- Double-cardanic type
- Compensating for high misalignment with low restoring forces
- Standard spacers available from stock

- Paper machines
- Printing and processing machines
- Materials handling
- Steel mills
- Generators
- Mill drives

- Double-cardanic type
- Spacers adapted to standard dimensions of pumps
- Radial assembly, no shifting of the machine required
- Available according to API 610

- Process pumps
- Water pumps
- Pumps according to API standard
- Turbines
- Compressors

- Customised spacers
- Max. shaft distance dimension up to approx. 6 m
- Welded intermediate pipes for high torsional stiffness

- Foil and paper machines
- Pallet and conveyor systems
- Robotic palletizers
- Test benches
- Cooling towers/blowers

- Customised spacers
- coupling consisting of 2-off type NN with intermediate shaft
- For drives with relatively low speeds

- Low-speed drives with large shaft distance dimensions
- Agitators
- Crushers
- Presses
- Packaging machinery

- Compact double-cardanic coupling
- Cannot be radially assembled
- With intermediate disk
- Ideally suitable for replacing curved-tooth gear couplings made of steel
- Standard type up to size 70

- Robotics
- Paper machines and inserters
- Machine tools
- Packaging machinery
- Test benches

- With reduced hubs
- Compact double-cardanic design
- Spacer cannot be radially assembled
- Variable spacer length

- Applications with short shaft distance dimensions
- Replacement of curved-tooth gear couplings made of steel

# RADEX®-N

## Steel laminae couplings

### Technical data

The following laminae types are to be distinguished with RADEX®-N:

Size 20 – 50  
(laminae with 4 holes)

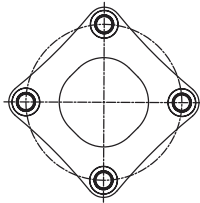

Size 60 – 135  
(laminae with 6 holes)

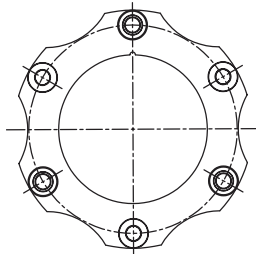

Size 136 – 336  
(laminae with 6 holes)

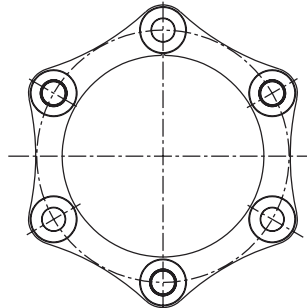

Size 138 – 338  
(laminae with 8 holes)

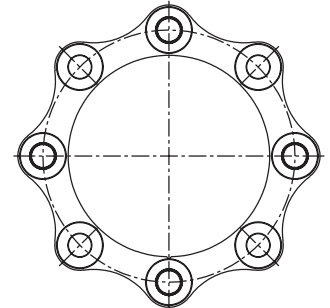

Torques and displacements									
Size	Laminae type	Torques [Nm] <sup>1)</sup>				Perm. displacements <sup>2)</sup>			
		TKN	TK max	TKW	Angular [°] each laminae	Axial [mm]		Radial [mm]	
						NN	NANA 1/ NANA 2/NNZ	NANA 1	NANA 2
20		30	60	15	1.0	0.60	1.2	1.0	0.2
25		60	120	30	1.0	0.80	1.6	1.0	0.2
35	laminae with 4 holes	120	240	60	1.0	1.00	2.0	1.1	0.3
38		240	480	120	1.0	1.20	2.4	1.2	0.3
42		320	640	160	1.0	1.40	2.8	1.2	0.4
50		470	940	235	1.0	1.60	3.2	1.5	0.4
60		900	1800	450	1.0	1.00	2.0	1.5	0.8
70		1300	2600	650	1.0	1.10	2.2	1.8	1.0
80		1800	3600	900	1.0	1.30	2.6	2.1	1.2
85		2600	5200	1300	1.0	1.30	2.6	2.2	1.2
90		4600	9200	2300	1.0	1.00	2.0	2.2	1.1
105		5600	11200	2800	1.0	1.20	2.4	2.4	1.4
115		9900	19800	4950	1.0	1.40	2.8	2.5	1.5
135	laminae with 6 holes	13500	27000	6750	1.0	1.75	3.5	3.8	–
136		17500	35000	8750	0.7	1.85	3.7		
156		25000	50000	12500	0.7	2.10	4.2		
166		35000	70000	17500	0.7	2.25	4.5		
186		42000	84000	21000	0.7	2.40	4.8		
206		52500	105000	26250	0.7	2.60	5.2		
246		90000	180000	45000	0.7	3.00	6.0		
286		150000	300000	75000	0.7	3.35	6.7		
336		210000	420000	105000	0.7	3.75	7.5		
138		23000	46000	11500	0.5	1.30	2.6	Depending on drop-out center dimension E	
158	33000	66000	16500	0.5	1.40	2.8			
168	45000	90000	22500	0.5	1.50	3.0			
188	laminae with 8 holes	56000	112000	28000	0.5	1.60	3.2		
208		70000	140000	35000	0.5	1.75	3.5		
248		120000	240000	60000	0.5	2.00	4.0		
288		200000	400000	100000	0.5	2.40	4.5		
338		280000	560000	140000	0.5	2.50	5.0		

Permissible speeds and torsional stiffness figures					
Size	Max. speed [rpm] (higher speeds on request)	Torsion spring stiffness x 10 <sup>6</sup> [Nm/rad] per laminae set	Size	Max. speed [rpm] (higher speeds on request)	Torsion spring stiffness x 10 <sup>6</sup> [Nm/rad] per laminae set
20	20400	0.02	156	3500	17.00
25	16800	0.03	166	3300	19.00
35	13900	0.11	186	3000	25.00
38	12000	0.20	206	2800	31.00
42	11000	0.28	246	2300	55.00
50	9000	0.50	286	2000	79.00
60	8200	0.56	336	1800	125.00
70	7300	0.90	138	3800	20.00
80	6300	1.10	158	3500	26.00
85	5900	1.50	168	3300	30.00
90	5400	2.00	188	3000	39.00
105	5000	2.50	208	2800	49.00
115	4300	3.50	248	2300	83.00
135	3700	6.90	288	2000	125.00
136	3800	13.00	338	1800	200.00

<sup>1)</sup> For selection of coupling see page 18 et seqq.

<sup>2)</sup> The permissible displacement figures specified are maximum figures which must not arise simultaneously. If axial, radial and angular displacement arises at the same time, these values must be reduced.

# RADEX®-N

## Steel laminae couplings

### Technical data

Weights and mass moments of inertia						
Size	Hub <sup>1)</sup> [kg] / [kgm <sup>2</sup> ]	Laminae set [kg] / [kgm <sup>2</sup> ]	NN <sup>1)</sup> complete [kg] / [kgm <sup>2</sup> ]	NANA 1 <sup>1)</sup> complete [kg] / [kgm <sup>2</sup> ]	NANA 2 <sup>1)</sup> complete [kg] / [kgm <sup>2</sup> ]	NNZ <sup>1)</sup> complete [kg] / [kgm <sup>2</sup> ]
20	0.13 / 0.000043	0.04 / 0.00002	0.3 / 0.00011	0.6 / 0.000204	-	0.4 / 0.000166
25	0.2 / 0.000116	0.08 / 0.00005	0.56 / 0.00028	0.9 / 0.000522	-	0.8 / 0.000414
35	0.6 / 0.00042	0.10 / 0.00010	1.2 / 0.00094	1.9 / 0.00158	-	1.6 / 0.00129
38	0.8 / 0.00073	0.20 / 0.00026	1.8 / 0.0017	2.8 / 0.00303	-	2.4 / 0.00247
42	1.1 / 0.00123	0.25 / 0.00040	2.4 / 0.0029	3.6 / 0.00482	-	3.1 / 0.00409
50	1.7 / 0.00291	0.46 / 0.0010	4.0 / 0.0068	6.2 / 0.0118	-	5.1 / 0.00932
60	1.9 / 0.00378	0.40 / 0.0012	4.2 / 0.0087	6.0 / 0.0141	5.8 / 0.0138	5.3 / 0.0120
70	2.8 / 0.00714	0.42 / 0.0016	6.0 / 0.016	8.6 / 0.0253	8.2 / 0.0242	7.5 / 0.0214
80	4.1 / 0.0134	0.72 / 0.0037	9.0 / 0.031	12.6 / 0.0476	12.0 / 0.0458	11.1 / 0.0410
85	5.1 / 0.0195	1.0 / 0.0065	11.2 / 0.046	16.2 / 0.0734	15.5 / 0.0711	14.8 / 0.0650
90	6.2 / 0.0282	2.3 / 0.0162	14.7 / 0.073	22.0 / 0.121	21.3 / 0.119	20.1 / 0.108
105	7.6 / 0.0414	2.2 / 0.0180	17.4 / 0.101	25.8 / 0.165	24.6 / 0.159	23.1 / 0.145
115	12.0 / 0.0899	4.0 / 0.0433	27.9 / 0.223	42.8 / 0.381	41.2 / 0.372	38.3 / 0.333
135	19.0 / 0.187	7.3 / 0.105	45.1 / 0.478	71.3 / 0.835	-	-
136	16.8 / 0.153	7.9 / 0.113	41.4 / 0.419	-	-	-
156	20.2 / 0.217	11.9 / 0.200	52.2 / 0.634	-	-	-
166	30.0 / 0.373	12.3 / 0.255	72.3 / 1.001	-	-	-
186	42.0 / 0.629	12.7 / 0.318	96.7 / 1.576	-	-	-
206	55.1 / 1.004	18.2 / 0.548	128.3 / 2.556	-	-	-
246	85.9 / 2.229	31.2 / 1.304	203.1 / 5.762	-	-	-
286	145.1 / 4.977	44.4 / 2.495	334.4 / 12.449	-	-	-
336	223.9 / 10.486	64.2 / 4.74	512.0 / 25.712	Depending on drop-out center dimension E	Depending on drop-out center dimension E	-
138	16.2 / 0.145	9.9 / 0.143	42.3 / 0.433	-	-	-
158	19.5 / 0.205	14.9 / 0.252	54.0 / 0.662	-	-	-
168	29.4 / 0.360	15.2 / 0.318	74.0 / 1.038	-	-	-
188	41.7 / 0.611	15.6 / 0.396	99.0 / 1.618	-	-	-
208	54.1 / 0.971	22.4 / 0.680	130.5 / 2.622	-	-	-
248	84.0 / 2.144	38.2 / 1.605	206.2 / 5.893	-	-	-
288	142.5 / 4.823	53.8 / 3.056	338.8 / 12.702	-	-	-
338	220.1 / 10.18	78.0 / 5.817	518.2 / 26.177	-	-	-

<sup>1)</sup> Hubs with max. bore

### Cylindrical bores

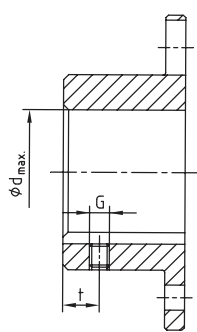

Standard hub 1.0 with feather keyway according to DIN 6885 sheet 1										
Size	dmax.	G	t	T <sub>A</sub> [Nm]	Size	dmax.	G	t	T <sub>A</sub> [Nm]	
20	20	M5	6	2.0	105	110	M12	30	40.0	
25	25	M5	8	2.0	115	120	M12	30	40.0	
35	38	M6	15	4.8	135	135				
38	42	M6	15	4.8	136 / 138	135				
42	50	M8	20	10.0	156 / 158	150				
50	55	M8	20	10.0	166 / 168	170				
60	65	M8	20	10.0	186 / 188	190				According to customer specification
70	75	M10	20	17.0	206 / 208	210				
80	85	M10	20	17.0	246 / 248	245				
85	90	M10	25	17.0	286 / 288	290				
90	100	M12	25	40.0	336 / 338	340				

### Backlash-free shaft-hub connections without feather key

Selection: If used in potentially explosive atmospheres the clamping ring hubs must be selected in that there is a minimum safety factor of  $s = 2$  between the peak torque of the machine including all operating parameters and the nominal torque and frictional locking torque of the coupling.

Clamping ring hub type 6.5  
(clamping screws from outside)

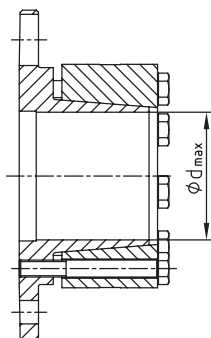

Clamping ring hub type 6.0  
(clamping screws from inside)

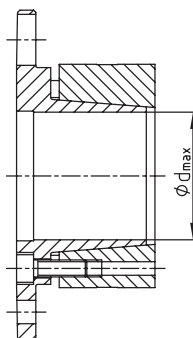

Type with CLAMPEX® element type 603

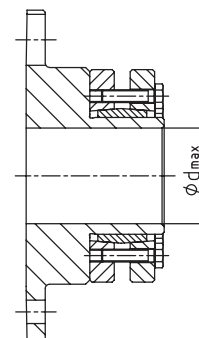

# RADEX®-N NN, NANA 1 and NANA 2 Steel laminae couplings

## Standard types



For legend of pictogram refer to flapper on the cover

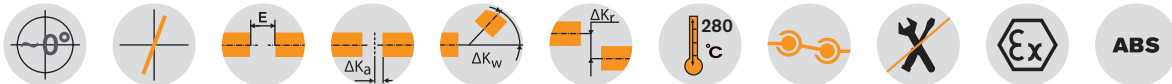

### Components

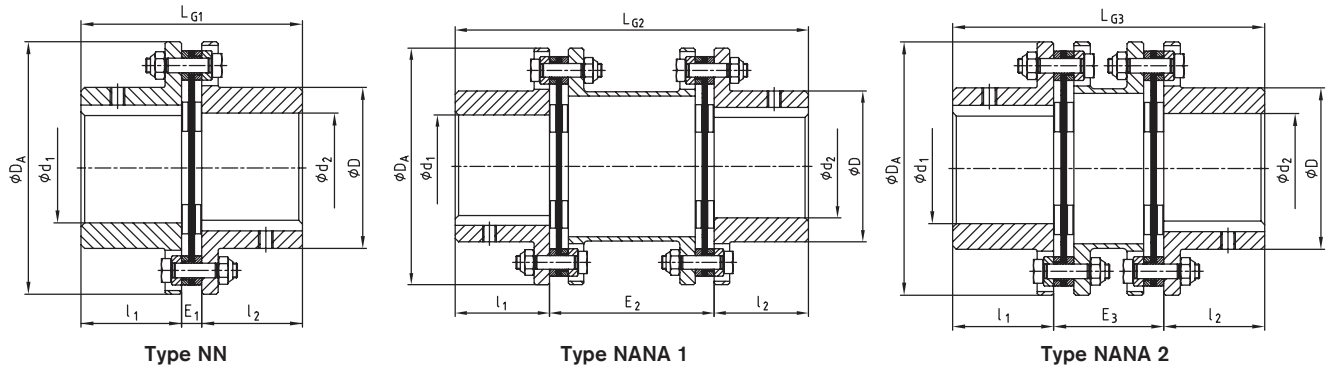

RADEX®-N Types NN, NANA 1, NANA 2										
Size	Max. finish bore	Dimensions [mm]								
	d <sub>1</sub> , d <sub>2</sub>	D	D <sub>A</sub>	l <sub>1</sub> , l <sub>2</sub>	L <sub>G1</sub>	E <sub>1</sub>	L <sub>G2</sub>	E <sub>2</sub>	L <sub>G3</sub>	E <sub>3</sub>
20	20	32	56	20	45	5	100	60	-	-
25	25	40	68	25	56	6	110	60	-	-
35	38	54	82	40	86	6	150	70	-	-
38	42	58	94	45	98	8	170	80	-	-
42	50	68	104	45	100	10	170	80	-	-
50	55	78	126	55	121	11	206	96	-	-
60	65	88	138	55	121	11	206	96	170	60
70	75	102	156	65	141	11	246	116	200	70
80	85	117	179	75	164	14	286	136	233	83
85	90	123	191	80	175	15	300	140	246	86
90	100	132	210	80	175	15	300	140	251	91
105	110	147	225	90	200	20	340	160	281	101
115	120	163	265	100	223	23	370	170	309	109
135	135	184	305	135	297	27	520	250	-	-
136	135	180	300	135	293	23				
156	150	195	325	150	327	27				
166	170	225	350	165	361	31				
186	190	250	380	185	401	31				
206	210	275	420	200	437	37				
246	245	320	500	240	524	44				
286	290	383	567	280	612	52				
336	340	445	660	330	718	58				
138	135	180	300	135	293	23				
158	150	195	325	150	327	27				
168	170	225	350	165	361	31				
188	190	250	380	185	401	31				
208	210	275	420	200	437	37				
248	245	320	500	240	524	44				
288	290	383	567	280	612	52				
338	340	445	660	330	718	58				

Ordering example:	RADEX®-N 60	NANA 1	Ø50	Ø60
	Coupling size	Type	Finish bore d <sub>1</sub>	Finish bore d <sub>2</sub>

# RADEX®-N NENA 1, NENA 2, NENE and NNZ Steel laminae couplings

## Standard types



For legend of pictogram refer to flapper on the cover

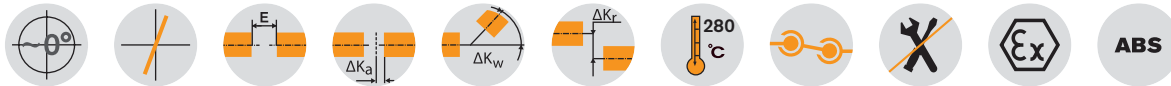

## Components

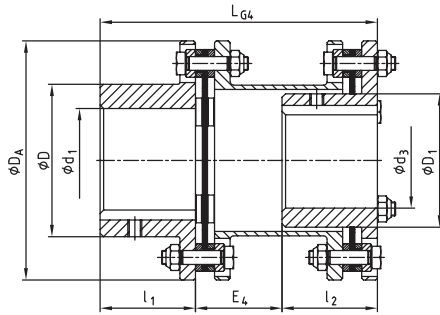

Type NENA 1

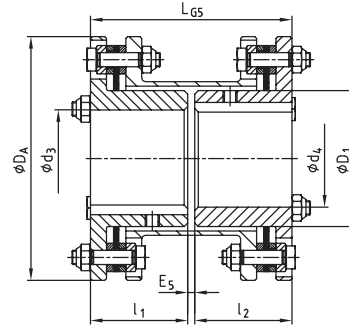

Type NENE

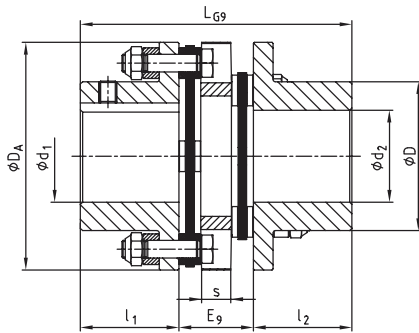

Type NNZ

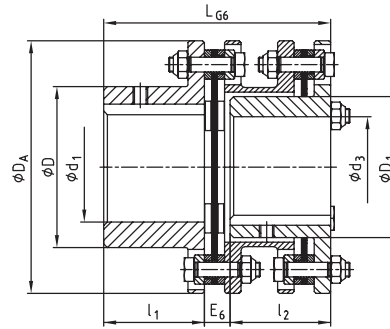

Type NENA 2

RADEX®-N Types NENA 1, NENE, NENA 2, NNZ

Size	Max. finish bore		Dimensions [mm]												
	d <sub>1</sub> , d <sub>2</sub>	d <sub>3</sub> , d <sub>4</sub>	D	D <sub>1</sub>	D <sub>A</sub>	l <sub>1</sub> , l <sub>2</sub>	LG4	E <sub>4</sub>	LG5	E <sub>5</sub>	LG6	E <sub>6</sub>	LG9	E <sub>9</sub>	
20	20	-	32	-	56	20	-	-	-	-	-	-	58	18	
25	25	-	40	-	68	25	-	-	-	-	-	-	70	20	
35	38	-	54	-	82	40	-	-	-	-	-	-	102	22	
38	42	-	58	-	94	45	-	-	-	-	-	-	118	28	
42	50	-	68	-	104	45	-	-	-	-	-	-	124	34	
50	55	-	78	-	126	55	-	-	-	-	-	-	144	34	
60	65	55	88	77	138	55	160	50	114	4	124	14	144	34	
70	75	65	102	90	156	65	190	60	134	4	144	14	166	36	
80	85	75	117	104	179	75	220	70	154	4	167	17	-	-	
85	90	80	123	112	191	80	232	72	164	4	178	18	-	-	
90	100	85	132	119	210	80	233	73	166	6	184	24	-	-	
105	110	90	147	128	225	90	263	83	186	6	204	24	-	-	
115	120	100	163	145	265	100	288	88	206	6	227	27	-	-	

Ordering example:

RADEX®-N 60	NENA 1	Ø50	Ø60
Coupling size	Type	Finish bore d <sub>1</sub>	Finish bore d <sub>2</sub>

# RADEX®-N NANA 4 and NNW Steel laminae couplings

## Customised types

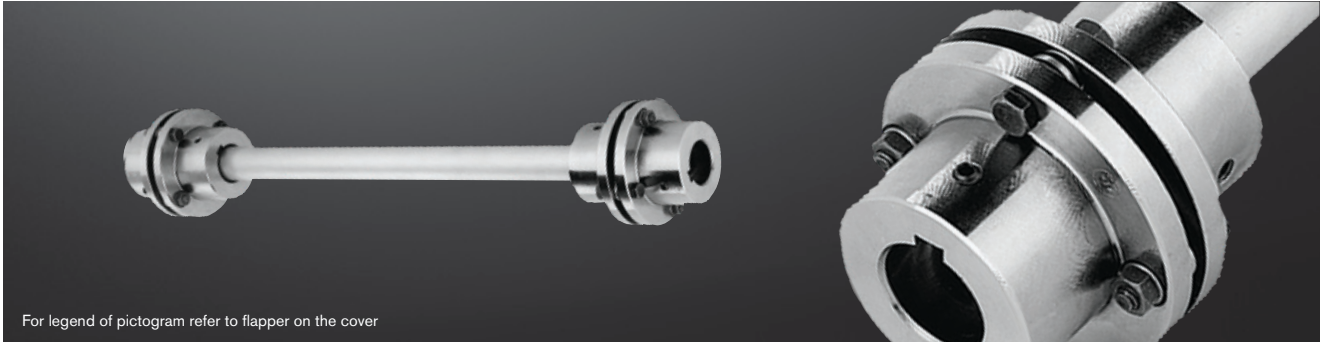

For legend of pictogram refer to flapper on the cover

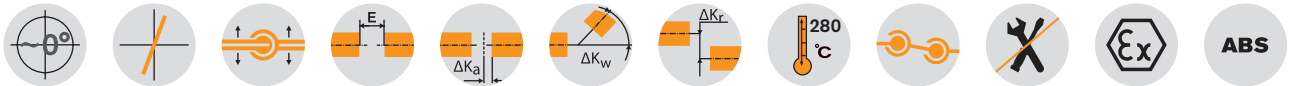

### Components

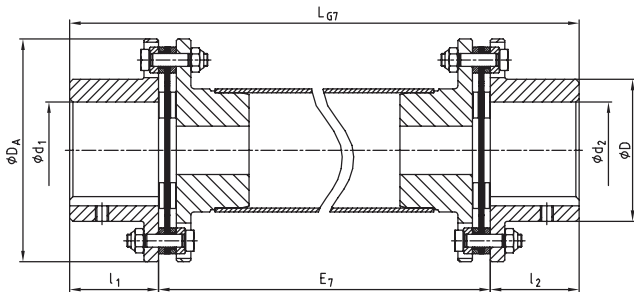

Type NANA 4

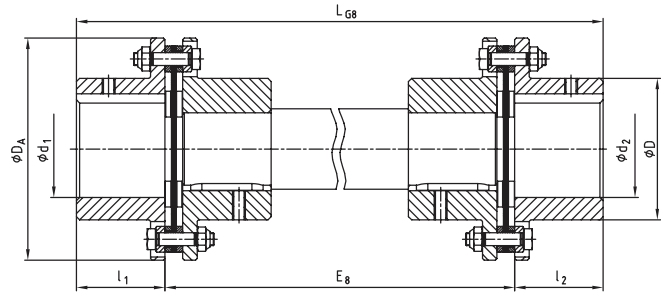

Type NNW

RADEX®-N Types NANA 4, NNZ and NNW								
Size	Max. finish bore	Dimensions [mm]						
	d <sub>1</sub> , d <sub>2</sub>	D	D <sub>A</sub>	l <sub>1</sub> , l <sub>2</sub>	LG7	E7	LG8	E8
20	20	32	56	20				
25	25	40	68	25				
35	38	54	82	40				
38	42	58	94	45				
42	50	68	104	45				
50	55	78	126	55				
60	65	88	138	55				
70	75	102	156	65				
80	85	117	179	75				
85	90	123	191	80				
90	100	132	210	80				
105	110	147	225	90				
115	120	163	265	100				
135	135	184	305	135				
136	135	180	300	135				
156	150	195	325	150				
166	170	225	350	165				
186	190	250	380	185				
206	210	275	420	200				
246	245	320	500	240				
286	290	383	567	280				
336	340	445	660	300				
138	135	180	300	135				
158	150	195	325	150				
168	170	225	350	165				
188	190	250	380	185				
208	210	275	420	200				
248	245	320	500	240				
288	290	383	567	280				
338	340	445	660	300				
					LG7 = E7 + l <sub>1</sub> + l <sub>2</sub>	Intermediate shaft dimension according to customer specification	LG8 = E8 + l <sub>1</sub> + l <sub>2</sub>	Intermediate shaft dimension according to customer specification

Ordering example:	RADEX®-N 60	NANA 4	Ø50	Ø60	2500
	Coupling size	Type	Finish bore d <sub>1</sub>	Finish bore d <sub>2</sub>	Shaft distance dimension

# RADEX®-N Composite Steel laminae couplings

Corrosion-resistant type for large shaft distances



For legend of pictogram refer to flapper on the cover



## Components

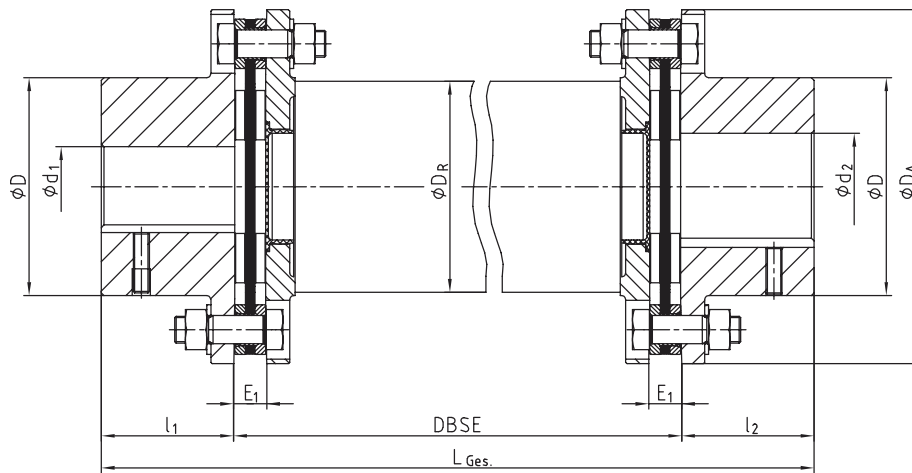

RADEX®-N Type NANA 4 CFK											
Size	Torque [Nm] <sup>1)</sup>		Dimensions [mm]								
	T <sub>KN</sub>	T <sub>K max</sub>	D <sub>A</sub>	d <sub>1</sub> , d <sub>2</sub> max.	D	l <sub>1</sub> , l <sub>2</sub>	E <sub>1</sub>	DBSE	L <sub>total</sub>	Composite tube D <sub>R</sub>	Max. DBSE <sup>2)</sup> with 1500 rpm
70	800	1600	149	75	102	65	11	As specified by the customer	l <sub>1</sub> + l <sub>2</sub> + DBSE	95	3500
85	1800	3600	184	90	123	80	15			117	3900
90	2500	5000	200	100	135	80	15			128	4100
115	4500	9000	253	120	163	100	23			160	4600

<sup>1)</sup> For selection of coupling see page 18 et seqq.

<sup>2)</sup> For higher speeds or bigger shaft distance dimensions please consult with KTR (+49 5971 798-484). The above-mentioned characteristic figures (e. g. max. DBSE) can be varied by Composite tubes optimized for the application, if necessary.

Particularly the steel laminae couplings are well suited for applications with especially large distance dimensions between the drive and the driven side (e. g. cooling towers, fans etc.) due to their design. In order to generate high speeds with large distance dimensions, RADEX®-N couplings with intermediate tubes made of glass fibre or carbon fibre reinforced nylon (GRP or CFRP) are used, if necessary.

Ordering example:	RADEX®-N 85	NANA 4 CFK	Ø60	Ø70	3000
	Coupling size	Type	Finish bore d <sub>1</sub>	Finish bore d <sub>2</sub>	Shaft distance dimension

# RADEX®-N NANA 3

## Steel laminae couplings

Pump drives in accordance with API 610



For legend of pictogram refer to flapper on the cover



RADEX®-N type NANA 3							
Size	Max. finish bore	Dimensions [mm]				Perm. displacements	
	d	D	DA	Estandard <sup>1)</sup>	l <sub>1</sub> , l <sub>2</sub>	Angular [°] each laminae	Axial [mm]
42	50	68	104	100	45	1.0	2.8
50	55	78	126	140/180	55	1.0	3.2
60	65	88	138	100/140/180/250	55	1.0	2.0
70	75	102	156	100/140/180	65	1.0	2.2
80	85	117	179	100/140/180/250	75	1.0	2.6
85	90	123	191	100/140/180/250	80	1.0	2.3
90	100	132	210	140/180/250	80	1.0	2.0
105	110	147	225	250	90	1.0	2.4
115	120	163	265	250	100	1.0	2.8
135	135	184	305	250	135	1.0	3.5
136	135	180	300		135	0.7	3.7
156	150	195	325		150	0.7	4.2
166	170	225	350		165	0.7	4.5
186	190	250	380		185	0.7	4.8
206	210	275	420		200	0.7	5.2
246	245	320	500		240	0.7	6.0
286	290	383	567		280	0.7	6.7
336	340	445	660	As specified by the customer	330	0.7	7.5
138	135	180	300		135	0.5	2.6
158	150	195	325		150	0.5	2.8
168	170	225	350		165	0.5	3.0
188	190	250	380		185	0.5	3.2
208	210	275	420		200	0.5	3.5
248	245	320	500		240	0.5	4.0
288	290	383	567		280	0.5	4.5
338	340	445	660		330	0.5	5.0

<sup>1)</sup> Other distance dimensions E available on request.

Ordering example:	RADEX®-N 60	NANA 3	Ø50	Ø60	140
	Coupling size	Type	Finish bore d <sub>1</sub>	Finish bore d <sub>2</sub>	Shaft distance dimension

## Components

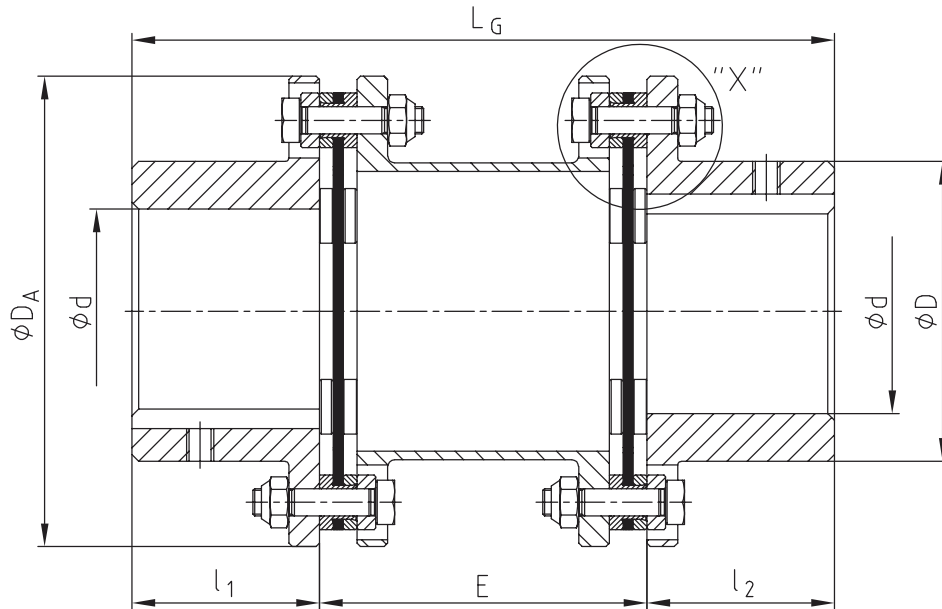

### Detail "X"

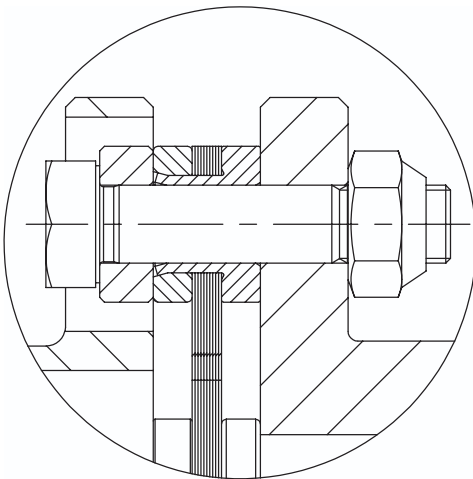

Safety catch of the spacer:  
The laminae sets are provided with a sleeve in order to secure the spacer in case if the laminas break.

# RIGIFLEX®-N

## Steel laminae couplings

### General advice

#### Advice on assembly and operation

See our mounting instructions KTR standard 47410 at [www.ktr.com](http://www.ktr.com). With the assembly it is important to make sure that the laminae sets are assembled free from distortion in axial direction.

If the finish bore is machined by the customer, the tolerances for concentricity and axial run-out have to be observed (see illustrations below).

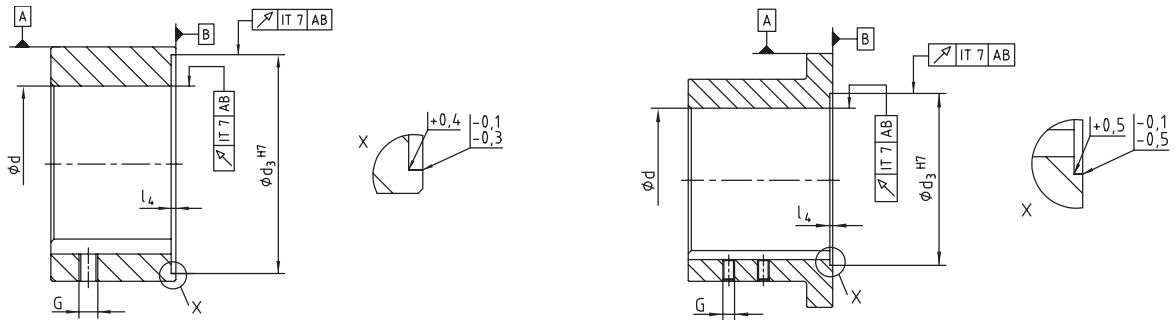

#### Installation

RIGIFLEX®-N couplings are designed for horizontal installation. With vertical installation the spacer must be supported, if necessary. Please consult with us.

#### Delivery condition

RIGIFLEX®-N-couplings are supplied as individual components (assembled on request), with the subassembly of spacers (flanges, laminae sets and spacer) being fully assembled. The hubs can be supplied unbored or with finish bore and feather keyway or with a frictionally engaged shaft-hub-connection. The shaft-hub-connection needs to be inspected by the customer (consult with KTR, if necessary).

#### Balancing

On request of the customer the RIGIFLEX®-N couplings can be balanced. Please consult with us, if necessary.

#### Safety regulations

The coupling has to be dimensioned in that the permissible coupling load is not exceeded during any operating condition. For this purpose the actual loads have to be compared to the permissible coupling parameters. The customer has to protect rotating parts from accidental contact (Safety of Machinery DIN EN 292 chapter 2). Take precautions to make sure there is sufficient coupling protection in case of fracture of the coupling caused by overload.

### Types of hubs

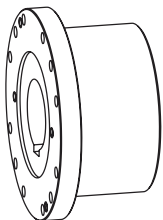

**Type 1.0 hub with feather keyway and setscrew**

Positive-locking torque transmission, permissible torque depending on the permissible surface pressure.

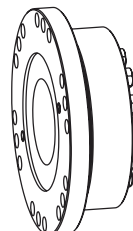

**Type with KTR 620 or 603 clamping set**

Frictionally engaged torque transmission with external clamping set KTR 620 or KTR 603. Transmittable torques depending on bore diameter.

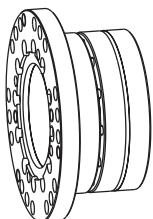

**Type 6.0 and 6.5 hub**

Integrated frictionally engaged shaft-hub-connection. Transmittable torques depending on bore diameter. Suitable for high speeds.

# RIGIFLEX®-N

## Steel laminae couplings

### Technical data

The following laminae types are to be distinguished with RIGIFLEX®-N:

Size 35 – 65  
(laminae with 4 holes)

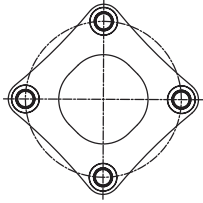

Size 75 – 160  
(laminae with 6 holes)

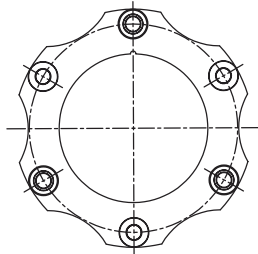

Size 166 – 406  
(laminae with 6 holes)

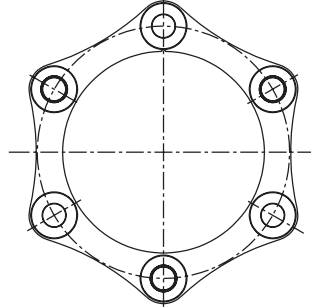

Size 168 – 408  
(laminae with 8 holes)

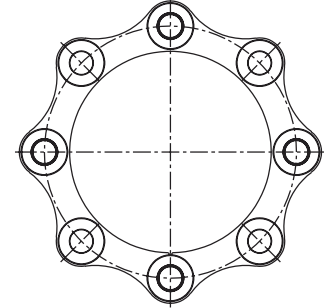

RADEX®-N

Laminae couplings

RIGIFLEX®-N

RIGIFLEX®-HP

### Torques and displacements

Size	Laminae type	Torques [Nm]			Perm. displacements						
		TKN	TK max	TKW	Angular displacement $\pm K_w^{1)}$ [°]	Axial displacement $\pm K_a$ [mm]	Radial $\pm K_r$ [mm]				
							E=100	E=140	E=180	E=200	E=250
35	laminae with 4 holes	130	260	65	0.7	1.2	0.90	1.40	–	–	–
50		270	540	135	0.7	1.4	0.77	1.26	–	–	–
65		550	1100	275	0.7	1.5	0.75	1.23	1.72	–	–
75		1100	2200	550	0.7	1.8	0.73	1.22	1.71	–	–
85		1900	3800	950	0.7	2.1	–	1.14	1.62	1.87	2.48
110		3500	7000	1750	0.7	2.4	–	1.05	1.54	1.78	2.39
120	laminae with 6 holes	5750	11500	2875	0.7	2.6	–	1.00	1.49	1.73	2.35
140		10500	21000	5250	0.7	3.3	–	–	–	1.55	2.16
160		16000	32000	8000	0.7	3.8	–	–	–	–	1.99
166		19000	38000	9500	0.7	3.7	Depending on shaft distance dimension E				
196		22500	45000	11250	0.7	4.2					
216		32000	64000	16000	0.7	4.5					
256		52500	105000	26250	0.7	5.2					
306		86000	172000	43000	0.7	6.0					
346		135000	270000	67500	0.7	6.7					
406		210000	420000	105000	0.7	7.5					
168	25000	50000	12500	0.5	2.6						
198	30000	60000	15000	0.5	2.8						
218	42500	85000	21500	0.5	3.0						
258	laminae with 8 holes	70000	140000	35000	0.5	3.5					
308		115000	230000	57500	0.5	4.0					
348		180000	360000	90000	0.5	4.5					
408		280000	560000	140000	0.5	5.0					

<sup>1)</sup> Angular displacement each laminae set

If axial, angular and radial shaft displacement arises in parallel observe the following table:

Size	Permissible angular displacement								
	0	0.1	0.2	0.3	0.4	0.5	0.6	0.7	
35	1.20	1.00	0.85	0.74	0.60	0.40	0.20	0.00	
50	1.40	1.20	1.00	0.80	0.60	0.40	0.20	0.00	
65	1.50	1.29	1.07	0.86	0.64	0.43	0.22	0.00	
75	1.80	1.54	1.29	1.03	0.77	0.52	0.26	0.00	
85	2.10	1.80	1.50	1.20	0.90	0.60	0.30	0.00	
110	2.40	2.06	1.71	1.37	1.03	0.69	0.34	0.00	
120	2.60	2.23	1.86	1.48	1.11	0.74	0.37	0.00	
140	3.30	2.83	2.36	1.88	1.41	0.94	0.47	0.00	
160	3.80	3.26	2.71	2.17	1.63	1.09	0.54	0.00	
166	3.70	3.17	2.64	2.12	1.59	1.06	0.53	0.00	
196	4.20	3.60	3.00	2.40	1.80	1.20	0.60	0.00	
216	4.50	3.86	3.21	2.57	1.93	1.29	0.64	0.00	
256	5.20	4.46	3.71	2.97	2.23	1.49	0.74	0.00	
306	6.00	5.14	4.29	3.43	2.57	1.72	0.86	0.00	
346	6.75	5.79	4.82	3.86	2.89	1.93	0.96	0.00	
406	7.50	6.43	5.36	4.28	3.21	2.14	1.07	0.00	
168	2.60	2.08	1.56	1.04	0.52	0.00	–	–	
198	2.80	2.24	1.68	1.12	0.56	0.00	–	–	
218	3.00	2.40	1.80	1.20	0.60	0.00	–	–	
258	3.50	2.80	2.10	1.40	0.70	0.00	–	–	
308	4.00	3.20	2.40	1.60	0.80	0.00	–	–	
348	4.50	3.60	2.70	1.80	0.90	0.00	–	–	
408	5.00	4.00	3.00	2.00	1.00	0.00	–	–	

# RIGIFLEX®-N

## Steel laminae couplings

### Technical data

Permissible speeds and stiffness figures								
Size	Max. speed [rpm]	per laminae set		ct [Nm/rad] for complete coupling with mounting length E				
		cw [Nm/rad]	ct x 10 <sup>6</sup> [Nm/rad]	E=100	E=140	E=180	E=200	E=250
35	23000	170	0.056	65020	56700	–	–	–
50	18000	490	0.27	73953	63990	–	–	–
65	13600	260	0.5	146022	129938	117046	–	–
75	12400	1000	0.67	306145	278381	255234	–	–
85	11000	1500	0.9	–	406641	369429	353265	318433
110	9000	1500	1.5	–	664284	637587	625028	595693
120	8000	3000	2.0	–	1798018	1637553	1567602	1416348
140	6400	10000	3.5	–	–	–	2363340	2226630
160	5600	10350	6.9	–	–	–	–	2654894
166	5600	26800	13.0					
196	5200	35800	17.0					
216	4600	41500	19.0					
256	3900	65000	31.0					
306	3300	112000	55.0					
346	2900	205000	79.0					
406	2500	276000	125.0					
168	5600	44300	20.0					
198	5200	82200	26.0					
218	4600	90000	30.0					
258	3900	138000	49.0					
308	3300	234000	83.0					
348	2900	416000	125.0					
408	2500	562000	200.0					

cw = angular stiffness  
ct = torsion spring stiffness

Weights and mass moments of inertia												
Size	Hub (max. bore)		Spacer complete [kg]					Spacer complete [kgm <sup>2</sup> ]				
	[kg]	[kgm <sup>2</sup> ]	E=100	E=140	E=180	E=200	E=250	E=100	E=140	E=180	E=200	E=250
35	0.60	0.0007	1.030	1.120	–	–	–	0.00040	0.00050	–	–	–
50	0.92	0.001019	2.262	2.442	–	–	–	0.00256	0.00263	–	–	–
65	2.7	0.00541	3.922	4.183	4.445	–	–	0.00810	0.00830	0.00828	–	–
75	2.4	0.00566	4.482	4.842	5.202	–	–	0.01143	0.01191	0.01239	–	–
85	3.7	0.01135	–	7.154	7.548	7.746	8.239	–	0.02364	0.02427	0.02459	0.02538
110	6.7	0.03222	–	12.492	13.478	13.972	15.205	–	0.06291	0.06540	0.06665	0.06976
120	9.2	0.05238	–	–	17.324	17.842	19.137	–	–	0.10314	0.10458	0.10818
140	18.2	0.15175	–	–	–	32.530	34.325	–	–	–	0.31901	0.32845
160	29.9	0.33890	–	–	–	–	52.458	–	–	–	–	0.68640
166	28.0	0.32										
196	37.0	0.554										
216	50.0	0.85										
256	95.0	2.35										
306	138.0	4.55										
346	215.0	9.75										
406	310.0	18.95										
168	30.0	0.33										
198	40.0	0.56										
218	52.0	0.88										
258	99.0	2.43										
308	142.0	4.78										
348	222.0	9.83										
408	325.0	19.22										

# RIGIFLEX®-N

## Steel laminae couplings

### Standard type A



For legend of pictogram refer to flapper on the cover

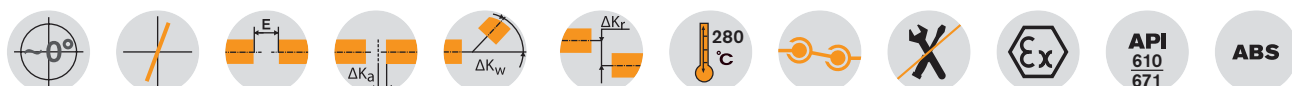

### Components

Size 35

Size 50 - 408

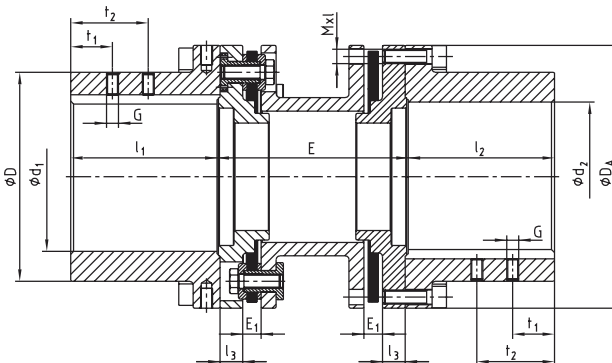
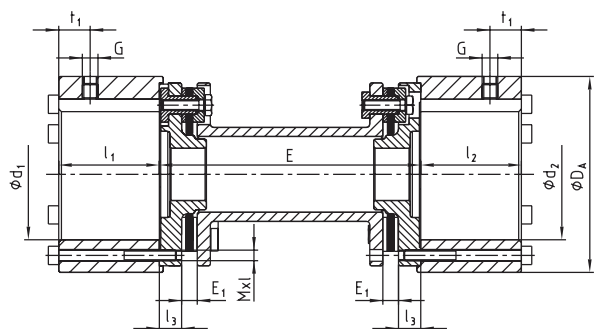

RIGIFLEX®-N type A

Size	Torques [Nm]			Max. finish bore d <sub>1</sub> , d <sub>2</sub>	Dimensions [mm]													Screws DIN EN ISO 4762	
	T <sub>KN</sub>	T <sub>K max</sub>	T <sub>KW</sub>		D	D <sub>A</sub>	l <sub>1</sub> , l <sub>2</sub>	l <sub>3</sub>	G	t <sub>1</sub>	t <sub>2</sub>	E <sub>1</sub>	E <sup>1)</sup>				Mxl	T <sub>A</sub> [Nm]	
35	130	260	65	50	-	75	38.5	8.5	M6	15	-	6	100	140	-	-	-	M4x45	4.1
50	270	540	135	50	70	95	50	12	M6	10	-	9	100	140	-	-	-	M6x22	14
65	550	1100	275	70	100	126	63	12	M8	20	-	11	100	140	180	-	-	M6x25	14
75	1100	2200	550	75	105	138	62.5	12	M8	20	-	11	100	140	180	-	-	M8x30	35
85	1900	3800	950	90	120	156	72.5	15	M10	20	-	12	-	140	180	200	250	M8x30	35
110	3500	7000	1750	110	152	191	87	18	M10	25	-	12	-	140	180	200	250	M10x35	69
120	5750	11500	2875	120	165	213	102	20	M12	25	-	12	-	-	180	200	250	M12x40	120
140	10500	21000	5250	150	200	265	126	25	M12	30	-	15	-	-	-	200	250	M16x50	295
160	16000	32000	8000	165	230	305	145	31	M12	30	-	15	-	-	-	-	250	M16x55	295
166	19000	38000	9500	165	230	305	155	31	M16	30	70	17					M20x50	560	
196	22500	45000	11250	195	260	330	185	32	M16	40	90	24					M20x50	560	
216	32000	64000	16000	210	285	370	205	32	M20	50	110	26					M20x65	560	
256	52500	105000	26250	260	350	440	245	38	M20	70	130	31					M24x80	970	
306	86000	172000	43000	305	400	515	295	43	M24	70	130	36					M27x100	1450	
346	135000	270000	67500	350	460	590	335	55	M24	95	175	45					M30x110	1950	
406	210000	420000	105000	405	530	675	395	58.5	M24	95	175	50	According to customer specification				M36x130	3300	
168	25000	50000	12500	165	230	305	155	31	M16	30	70	17					M20x50	560	
198	30000	60000	15000	195	260	330	185	32	M16	40	90	24					M20x50	560	
218	42500	85000	21500	210	285	370	205	32	M20	50	110	26					M20x65	560	
258	70000	140000	35000	260	350	440	245	38	M20	70	130	31					M24x80	970	
308	115000	230000	57500	305	400	515	295	43	M24	70	130	36					M27x100	1450	
348	180000	360000	90000	350	460	590	335	55	M24	95	175	45					M30x110	1950	
408	280000	560000	140000	405	530	675	395	58.5	M24	95	175	50					M36x130	3300	

<sup>1)</sup> Other shaft distance dimensions available on request.  
For selection of coupling see page 18 et seqq. Assembly instructions of KTR standard 47410 available at [www.ktr.com](http://www.ktr.com).

Ordering example:	RIGIFLEX®-N 120	A	Ø 100	Ø 120	200
	Coupling size	Type	Bore d <sub>1</sub>	Bore d <sub>2</sub>	Shaft distance dimension E

# RIGIFLEX®-N

## Steel laminae couplings

### Standard type A-J

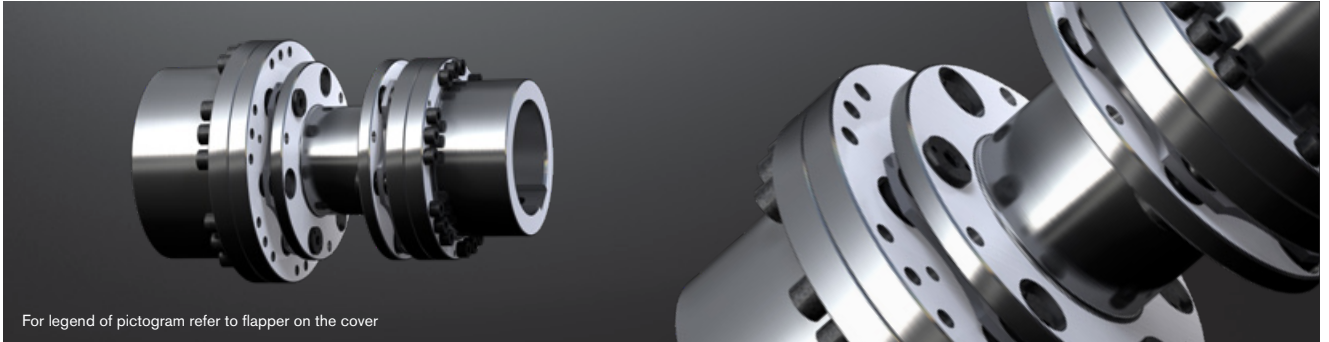

For legend of pictogram refer to flapper on the cover



### Components

Size 50 - 140

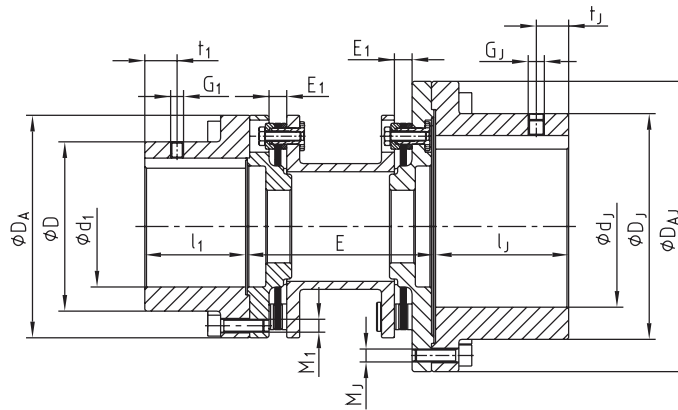

RIGIFLEX®-N type A-J																									
Size	Torques [Nm]			Max. finish bore		Dimensions [mm]														Screws DIN EN ISO 4762					
	TKN	TK max	TKW	d <sub>1</sub>	d <sub>2</sub>	D	D <sub>A</sub>	l <sub>1</sub>	D <sub>J</sub>	D <sub>AJ</sub>	l <sub>2</sub>	G <sub>1</sub>	t <sub>1</sub>	G <sub>2</sub>	t <sub>2</sub>	E <sub>1</sub>	E <sup>1)</sup>				M 1	T <sub>A</sub> [Nm]	M <sub>J</sub>	T <sub>AJ</sub> [Nm]	
50	270	540	135	50	70	70	95	50	100	126	63	M6	10	M8	20	9	100	140	-	-	-	M6	14	M6	14
65	550	1100	275	70	90	100	126	63	120	156	72.5	M8	20	M10	20	11	100	140	180	-	-	M6	14	M8	35
75	1100	2200	550	75	100	105	138	62.5	140	180	83	M8	20	M10	20	11	100	140	180	-	-	M8	35	M8	35
85	1900	3800	950	90	110	120	156	72.5	152	191	87.5	M10	20	M10	25	12	-	140	180	200	250	M8	35	M10	69
110	3500	7000	1750	110	150	152	191	87	200	265	127	M10	25	M12	30	12	-	140	180	200	250	M10	69	M16	295
120	5750	11500	2875	120	165	165	213	102	230	305	147	M12	25	M12	30	12	-	180	200	250	M12	120	M16	295	
140	10500	21000	5250	150	195	200	265	126	260	330	186	M12	30	M16	40/90	15	-	-	-	200	250	M16	295	M20	560
160	16000	32000	8000	165	210	230	305	145	285	370	205	M12	30	M20	50/60	15	-	-	-	200	250	M16	295	M20	560

<sup>1)</sup> Other shaft distance dimensions available on request.

For selection of coupling see page 18 et seqq. Assembly instructions of KTR standard 47410 available at [www.ktr.com](http://www.ktr.com).

### Other types:

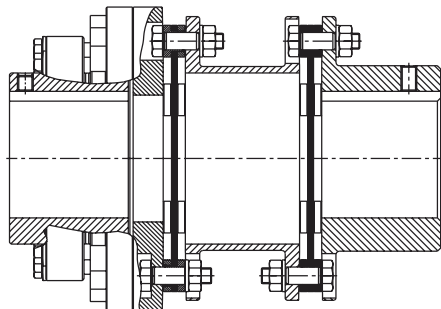

For RADEX®-N with integrated slipping unit see dimension sheet 699206

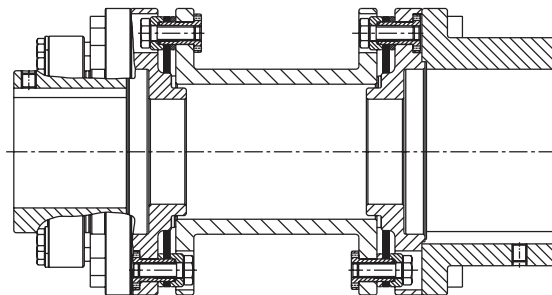

For RIGIFLEX®-N with integrated slipping unit see dimension sheet 698869

Ordering example:	RIGIFLEX®-N 85	A-J	Ø 80	Ø 120	200
	Coupling size	Type	Bore d <sub>1</sub>	Bore d <sub>2</sub>	Shaft distance dimension E

# RIGIFLEX®-N

## Steel laminae couplings

### Standard type A-H

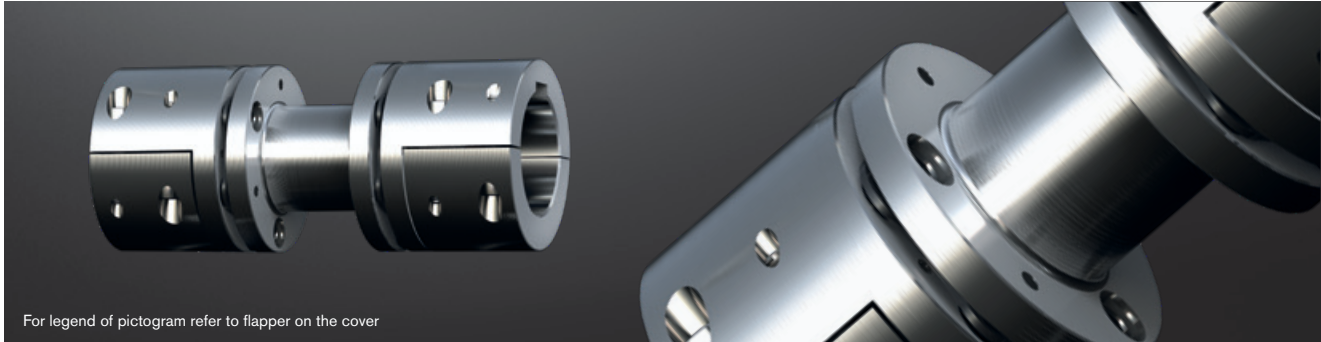

For legend of pictogram refer to flapper on the cover

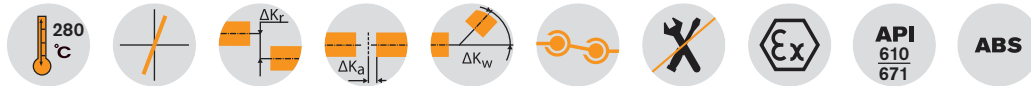

### Components

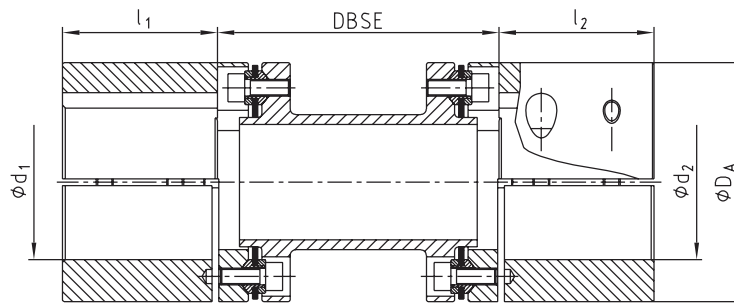

RIGIFLEX®-N type A-H											
Size	Torques [Nm]		Max. finish bore [mm]		Dimensions [mm]						
	T <sub>KN</sub>	T <sub>K max</sub>	d <sub>1</sub> , d <sub>2</sub>	D <sub>A</sub>	l <sub>1</sub> , l <sub>2</sub>	Standard shaft distance dimension DBSE <sup>1)</sup>			Perm. axial displacement	Perm. angular displacement (per laminae set [°])	
46	90	180	42	69	45					+/- 1.4	1.0
56	255	510	55	85	55	100				+/- 1.2	0.7
66	450	900	65	105	65		140	180	250	+/- 1.6	0.7
76	975	1950	75	124	75					+/- 1.8	0.7
86	1500	3000	85	145	85	-				+/- 2.2	0.7
106	2400	4800	105	168	105		-			+/- 2.4	0.7

<sup>1)</sup> Other shaft distance dimensions (DBSE) available on request

### Benefits of type A-H:

- Hub type 7.6 - half shell hub
- Easy and quick radial assembly and disassembly
- Type according to API 610 and 671 (see exceptions)
- Drop-out protection of spacer with fracture of laminae following API 671

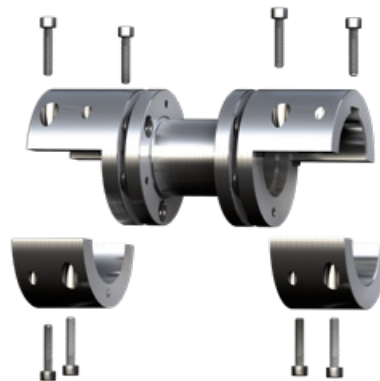

### Ordering example:

RIGIFLEX®-N 66	A-H	Ø 42	Ø 48	140
Coupling size	Type	Bore d <sub>1</sub>	Bore d <sub>2</sub>	Shaft distance dimension DBSE

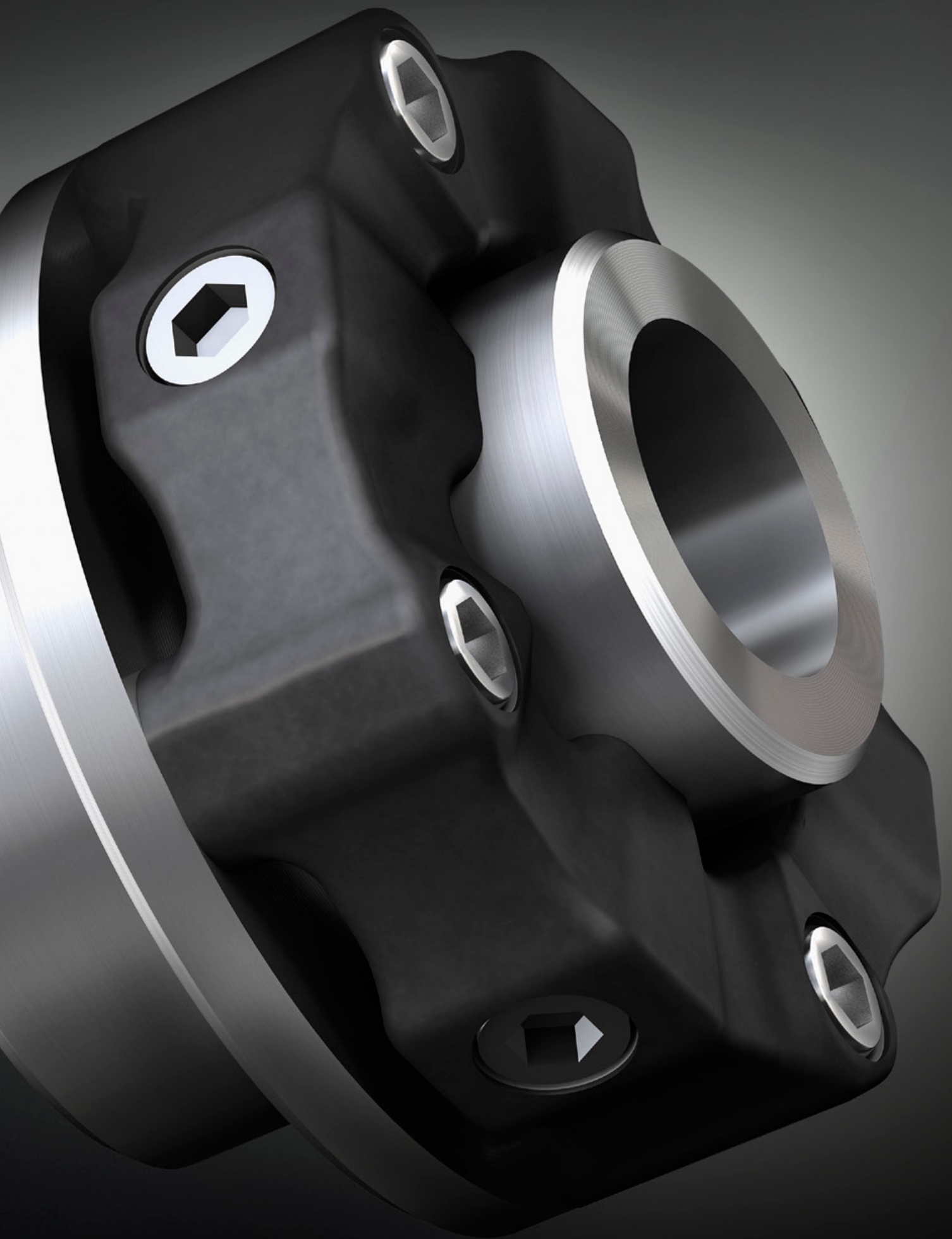

# Highly flexible shaft couplings

Types and operating description 192

---

## EVOLASTIC®

Description of product and application 194

Type E 196

Type EH 197

Type E2H 198

Type EFH 199

Type EP 200

Type EHP 201

Type E2HP 202

Type EFHP 203

Type D2H 204

Type DFH 205

---

## BoWex-ELASTIC®

Type HEW Compact 206

EVOLASTIC®



BoWex-ELASTIC® HEW Compact



# HIGHLY FLEXIBLE SHAFT COUPLINGS

## TYPES AND OPERATING DESCRIPTION

### Properties of highly flexible shaft couplings

		
<b>Product</b>	<b>EVOLASTIC®</b>	<b>BoWex® HEW Compact</b>
Type	Highly flexible jaw coupling	Highly flexible gear coupling
<b>Features</b>		
Highly flexible	●	●
Damping vibrations	●	
Maintenance-free	●	●
Axial plug-in	●	●
Shear type		●
Fail-safe	●	
Compensating for misalignment	●	●
<b>Types</b>		
Variant diversity	very high	medium
Special features	compensating for high displacements, compact design single- and double-cardanic	low restoring forces, compact design, single-cardanic
Applications / core industries	flexible all-rounder coupling for applications, among other things, in mechanical and plant engineering as well as agricultural machinery	rotation-critical applications such as screw compressors, piston compressors or transfer pumps
<b>Torque range <math>T_{KN}</math> [Nm]</b>		
Min.	100	200
Max.	5,600	8,400
<b>Max. circumferential speed <math>v</math> [m/s]</b>		
Steel + cast EN-GJS (dynamic balancing)	60	50
<b>Hub materials available</b>		
Steel (semi-finished product) » customised solutions available	●	●
Stainless steel	○	○
Corrosion-protected types	○	○
<b>Elastomers</b>		
Material	NR + EPDM	NR + EPDM
Degree of hardness	W, S, M	40 - 70 Shore A
Temperature range in [°C] min./ max. (NR)	-40 / +100	-40 / +100
Temperature range in [°C] min./max. (EPDM)	-30 / +120	-30 / +120

● ≈ Standard  
○ ≈ On request

# HIGHLY FLEXIBLE SHAFT COUPLINGS

## TYPES AND OPERATING DESCRIPTION

### Product finder for highly flexible shaft couplings

		
<b>Product</b>	<b>EVOLASTIC®</b>	<b>BoWex® HEW Compact</b>
Type	Highly flexible jaw coupling	Highly flexible gear coupling
<b>Geometries</b>		
Design	very short	short
Mass moment of inertia	low	low
Shaft distance dimension	small to large (depending on design)	low
<b>Types (extract)</b>		
Elastomers can be radially disassembled » without displacing driving/driven side	D2H, DFH	–
shaft-to-shaft connection	EH, E2H, EHP, E2HP	Standard
flange-to-shaft connection	EFH, EFHP, DFH	–
Double-cardanic » compensating for big displacements, lower restoring forces » bridging bigger shaft distances	D2H, DFH	–
<b>Certifications / type examinations</b>		
ATEX 	○	●
GOST R / GOST TR 	○	●
DNV/GL 	○	●
Bureau Veritas 	○	●

● = Standard  
○ = On request

# EVOLASTIC®

## Highly flexible couplings

### Description of product and application

The EVOLASTIC® is a highly flexible, failure-protected and backlash-free shaft and flange coupling for versatile use in a large number of main and auxiliary drives in mechanical and plant engineering.

Subject to the elastomer pre-stressed to pressure, the coupling is able to reduce and dampen torsional vibrations in the drive train and absorb overload shocks smoothly. Axial, radial and angular displacements are well balanced by the coupling.

The key component of this series is a vulcanised, circularly closed elastomer made of natural rubber (WN, SN, MN, up to 100 °C) or for higher temperatures made of synthetical EPDM material (WE, SE, ME, up to 120 °C).

The basic variants distinguish between directly screwed types and pluggable types. They cover all convenient mounting conditions ranging from a finished individual component through hub/hub and flange/hub applications to the driving shaft. Apart from that the product portfolio allows for highly individual and flexible mounting options, tailor-made for the special application.



Technical data														
Size	Elastomer type <sup>2)</sup>	Torque [Nm]				Perm. speed [rpm]	Perm. damping power P <sub>KW</sub> [W]		Dynamic torsion spring stiffness C <sub>dyn</sub> [Nm/rad]		Relative damping ψ [-]		Radial spring stiffness C <sub>r</sub> [N/mm]	
		TKN <sup>1)</sup>	TK <sub>max</sub> 50,000 load alternations [Nm]	TK <sub>max</sub> 1,000 load alternations [Nm]	TK <sub>W</sub>		30 °C	60 °C	30 °C	60 °C	30 °C	60 °C	30 °C	60 °C
						η <sub>max.</sub>								
12	SN	100	200	300	40	5,000	25	15	900	720	0.80	0.64	280	224
	MN	120	240	360	48	6,000			1,500	1,200	1.10	0.88	400	320
24	SN	200	400	600	80	4,200	40	24	2,000	1,600	0.80	0.64	400	320
	MN	240	480	720	96	5,000			3,600	2,880	1.10	0.88	550	440
32	SN	280	560	840	112	4,200	50	30	6,500	5,200	0.80	0.64	1,100	880
	MN	320	640	960	128	5,000			9,500	7,600	1.10	0.88	1,700	1,360
48	SN	420	840	1,260	168	4,200	75	45	6,800	5,440	0.80	0.64	1,000	800
	MN	480	960	1,440	192	5,000			13,500	10,800	1.10	0.88	1,500	1,200
60	SN	500	1,000	1,500	200	3,600	80	48	4,600	3,680	0.80	0.64	440	352
	MN	600	1,200	1,800	240	4,000			7,750	6,200	1.10	0.88	650	520
86	SN	760	1,520	2,280	304	4,000	90	54	12,500	10,000	0.90	0.72	1,300	1,040
	MN	860	1,720	2,580	344	4,500			21,000	16,800	1.10	0.88	1,625	1,300
125	SN	1,100	2,200	3,300	440	3,200	120	72	8,800	7,040	0.80	0.64	650	520
	MN	1,250	2,500	3,750	500	3,600			16,000	13,600	1.10	0.88	920	736
200	SN	1,700	3,400	5,100	680	3,400	150	90	29,000	23,200	0.90	0.72	1,700	1,360
	MN	2,000	4,000	6,000	800	3,600			44,000	35,200	1.10	0.88	2,125	1,700
280	WN	2,400	4,800	7,200	960	3,000	170	102	38,000	30,400	0.70	0.56	1,150	920
	MN	2,800	5,600	8,400	1,120	3,400			78,000	62,400	1.10	0.88	2,800	2,240
360	WN	3,200	6,400	9,600	1,280	3,000	200	120	48,500	38,800	0.70	0.56	1,800	1,440
	SN	3,400	6,800	10,200	1,360	3,400			67,000	53,600	0.90	0.72	2,200	1,760
560	MN	3,600	7,200	10,800	1,440	3,400	240	144	115,000	92,000	1.10	0.88	2,500	2,000
	WN	5,000	10,000	14,000	2,000	2,500			73,500	58,800	0.80	0.64	1,950	1,560
560	SN	5,200	10,400	14,000	2,080	2,800	240	144	105,000	84,000	1.00	0.80	2,500	2,000
	MN	5,600	11,200	14,000	2,240	3,000			138,000	110,400	1.10	0.88	3,000	2,400

<sup>1)</sup> TKN Torque that can be constantly transmitted over the entire speed range.  
<sup>2)</sup> Observe with selection DIN 740 part II (operating factor, temperature factor), parameters for an ambient temperature of 30 °C  
<sup>2)</sup> Other types of elastomers available on request

### Types

Types axially screwed+	
E	Elastomer + set of screws
EH	Elastomer + hub (radial)
E2H	Elastomer + two hubs (1x axial / 1x radial)
EFH	Elastomer + flange + hub (radial)
D2H	Two elastomers + intermediate shaft + two hubs (axial)
DFH	Two elastomers + intermediate shaft + flange and hub (axial)



Types plugged in axially	
EP	Elastomer (pluggable) + locking pin (radial)
EHP	Elastomer (pluggable) + hub (radial)
E2HP	Elastomer (pluggable) + two hubs (1x axial / 1x radial)
EFHP	Elastomer (pluggable) + flange + hub (radial)



# EVOLASTIC®

## Highly flexible couplings

### Types of hubs

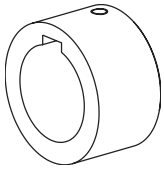

**Type 1.0**  
with feather keyway  
and setscrew

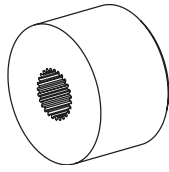

**Type 1.3**  
spline toothing

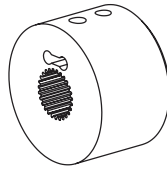

**Type 3.1**  
spline/clamping hub N

Other hub types on request.

**Examples:**

- slotted clamping hub
- taper or cylindrical press fit

### Displacements / Displacement stiffness

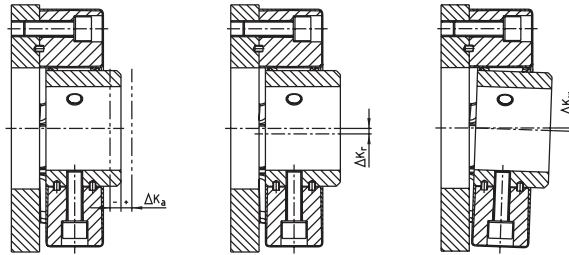

Displacements																									
Size	12		24		32		48		60		86		125		200		280		360		560				
Elastomer type	SN	MN	SN	MN	SN	MN	SN	MN	SN	MN	SN	MN	SN	MN	SN	MN	SN	MN	WN	SN	MN	WN	SN	MN	
Perm. radial displacement $\Delta K_r$ [mm]	1,500 rpm	1.9	1.4	2.0	1.5	1.4	0.9	1.8	1.2	2.5	1.9	1.6	1.3	2.5	2.0	1.8	1.4	2.5	1.4	2.3	1.8	1.6	2.3	1.8	1.6
	Max. <sup>1)</sup>	3.6	3.6	3.6	3.6	3.6	3.6	3.6	4.5	4.5	3.6	3.6	4.5	4.5	4.5	4.5	4.5	4.5	4.5	5.4	5.4	5.4	5.4	5.4	5.4
Perm. angular displacement $\Delta K_w$ [°]	1,500 rpm	3.0	3.0	2.0	2.0	2.0	2.0	3.0	3.0	2.0	2.0	3.0	3.0	2.0	2.0	2.0	2.0	2.0	2.0	2.0	2.0	2.0	2.0	2.0	2.0
	Max. <sup>1) 2)</sup>	6.0	6.0	4.0	4.0	4.0	4.0	6.0	6.0	4.0	4.0	6.0	6.0	4.0	4.0	4.0	4.0	4.0	4.0	4.0	4.0	4.0	4.0	4.0	4.0
Perm. axial displacement $\Delta K_a$ [mm]	±2.5		±3.0		±3.0		±2.5		±3.0		±3.0		±3.5		±3.0		±3.5		±4.0		±4.0		±4.0		

<sup>1)</sup> For short-term start-up operation  
<sup>2)</sup> Check for cardanic free movement

The radial and angular displacement of a coupling element refers to an operating speed of 1,500 rpm. Following the graph the permissible operating displacement increases with lower speed or reduces with rising speed by the factor  $f_{rpm}$ . The combination of radial and angular displacement in an application is divided up as a percentage. The permissible displacement refers to the total of alignment and operating displacement.

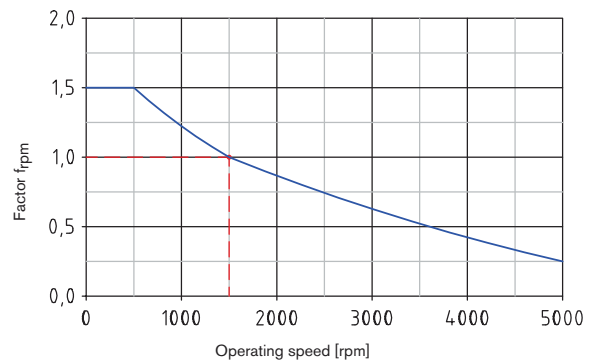
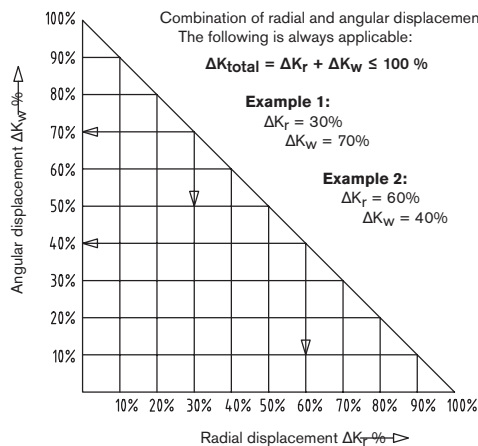

# EVOLASTIC® E

## Highly flexible couplings

Individual element - available in various kinds of Shore hardness



For legend of pictogram refer to flapper on the cover

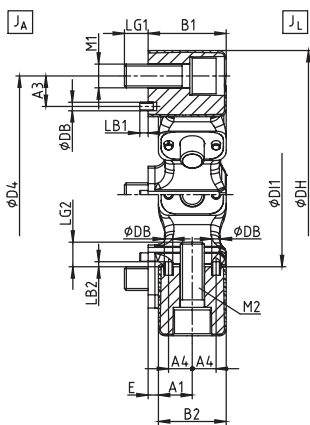

Size 12 - 280

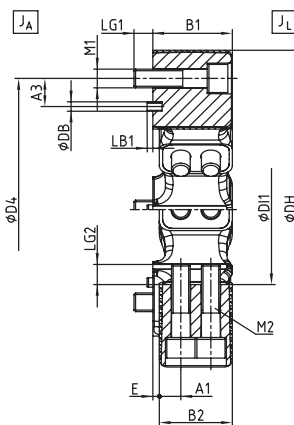

Size 360 - 560

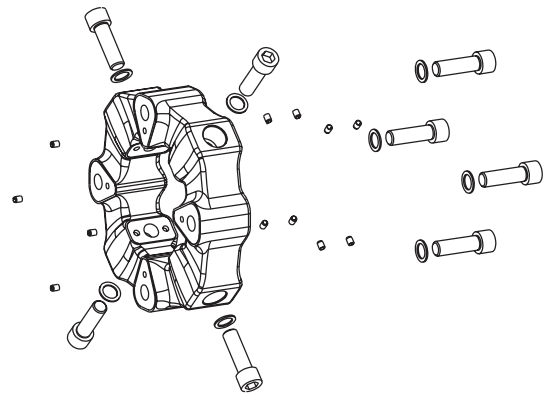

EVOLASTIC® type E																		
Size	Dimensions [mm]															Mass moment of inertia [kgm <sup>2</sup> ]		Weight [kg]
	DH	DI1	B1	B2	E	D4	Z x Pitch	A3	LG	LB1	DB	A1	A4	LB2	JA	JL		
	12	122	60	32	28	4	100	3 x 120°	12	10	4	4	14.0	10.0	-	0.0005	0.0005	
24	150	70	42	36	6	125	3 x 120°	18	12	4	5	18.0	13.5	5	0.0010	0.0010	0.93	
32	150	70	42	36	6	125	4 x 90°	18	12	4	5	18.0	13.5	5	0.0020	0.0020	1.13	
48	170	85	46	40	6	140	4 x 90°	18	14	5	5	20.0	14.0	5	0.0040	0.0030	1.55	
60	200	100	58	50	8	165	3 x 120°	20	16	5	5	25.0	18.0	5	0.0070	0.0070	2.28	
86	200	100	58	50	8	165	4 x 90°	20	16	5	5	25.0	18.0	5	0.0090	0.0080	2.76	
125	260	125	70	63	7	215	3 x 120°	25	20	5	8	31.5	22.5	5	0.0240	0.0220	4.74	
200	260	125	70	63	7	215	4 x 90°	25	20	5	8	31.5	22.5	5	0.0300	0.0280	5.79	
280	300	145	80	72	8	250	4 x 90°	25	20	5	8	36.0	22.5	5	0.0550	0.0500	7.89	
360	340	160	85	78	7	280	4 x 90°	30	20	6	10	2 x 23.0	-	-	0.0960	0.0950	11.50	
560	363	170	105	95	10	300	4 x 90°	40	24	6	10	2 x 28.5	-	-	0.1510	0.1450	15.38	

### Delivery condition:

EVOLASTIC® couplings type E are supplied with a mounting kit consisting of cap screws, screw locking washers and positioning sleeves. With the connection design make sure sufficient screw-in depth.

Size	Cap screw DIN EN ISO 4762 - 12.9		Tightening torque TA [Nm]
	M1 / axial	M2 / radial	
12	M10 x 30	M10 x 30	71
24	M12 x 35	M12 x 35	123
32	M12 x 35	M12 x 35	123
48	M14 x 40	M14 x 40	195
60	M16 x 50	M16 x 50	302
86	M16 x 50	M16 x 50	302
125	M20 x 65	M20 x 65	592
200	M20 x 65	M20 x 65	592
280	M20 x 65	M20 x 65	592
360	M20 x 80	M20 x 80	592
560	M24 x 90	M20 x 90	1,017 / 592

Ordering example:	EVOLASTIC® 48	E	SN
	Coupling size	Type	Elastomer type

# EVOLASTIC® EH

## Highly flexible couplings

### Individual element + shaft connection



For legend of pictogram refer to flapper on the cover

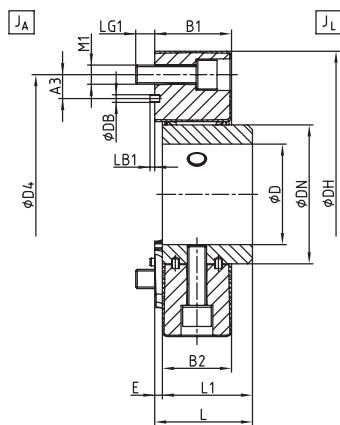

Size 12 - 280

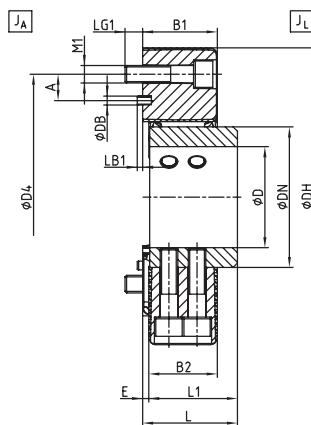

Size 360 - 560

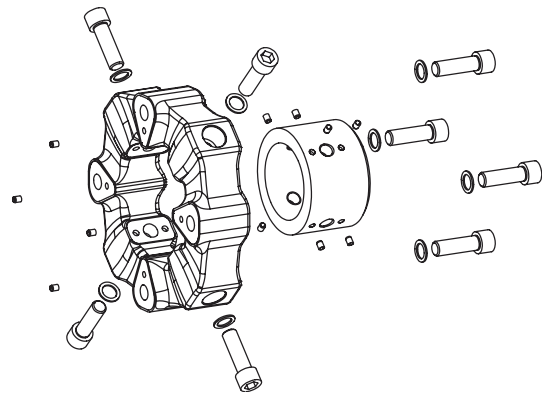

EVOLASTIC® type EH																		
Size	Dimensions [mm]															Mass moment of inertia [kgm <sup>2</sup> ] <sup>1)</sup>		Weight [kg] <sup>1)</sup>
	Max. finish bore D	DH	DN	B1	B2	E	L	L1	D4	Z x Pitch	M1	A3	LG	LB1	DB	J <sub>A</sub>	J <sub>L</sub>	
	12	38	122	60	32	28	4	46	42	100	3 x 120°	M10	12	10	4	4	0.0006	
24	46	150	70	42	36	6	56	50	125	3 x 120°	M12	18	12	4	5	0.0016	0.0021	1.76
32	46	150	70	42	36	6	56	50	125	4 x 90°	M12	18	12	4	5	0.0020	0.0030	1.95
48	55	170	85	46	40	6	61	55	140	4 x 90°	M14	18	14	5	5	0.0040	0.0050	2.90
60	65	200	100	58	50	8	74	66	165	3 x 120°	M16	20	16	5	5	0.0070	0.0110	4.55
86	65	200	100	58	50	8	74	66	165	4 x 90°	M16	20	16	5	5	0.0090	0.0120	5.03
125	85	257	125	70	63	7	88	80	215	3 x 120°	M20	25	20	5	8	0.0240	0.0340	8.77
200	85	257	125	70	63	7	88	80	215	4 x 90°	M20	25	20	5	8	0.0300	0.0400	9.80
280	105	299	145	80	72	8	102	94	250	4 x 90°	M20	25	20	5	8	0.0560	0.0730	13.54
360	115	340	160	85	78	7	108	100	280	4 x 90°	M20	30	20	6	10	0.0960	0.1320	18.85
560	120	363	170	105	95	10	135	125	300	4 x 90°	M24	40	24	6	10	0.1530	0.2080	26.34

<sup>1)</sup> With max. bore

EVOLASTIC®

Highly flexible shaft couplings

BoWex-ELASTIC® HEW Compact

Ordering example:	EVOLASTIC® 48	EH	SN	1.0	Ø52
	Coupling size	Type	Elastomer type	Hub type	Finish bore

# EVOLASTIC® E2H

## Highly flexible couplings

### shaft-to-shaft connection

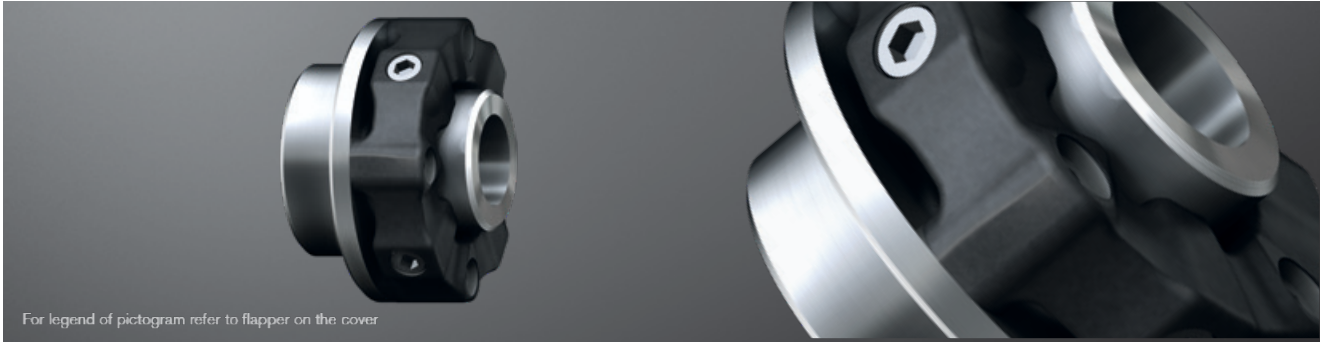

For legend of pictogram refer to flapper on the cover

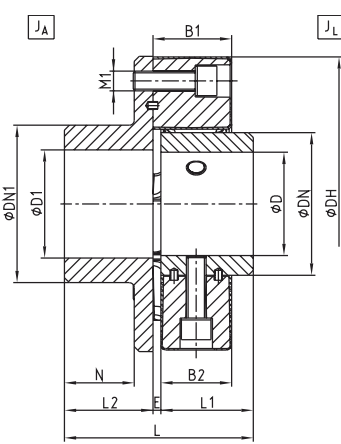

Size 12 - 280

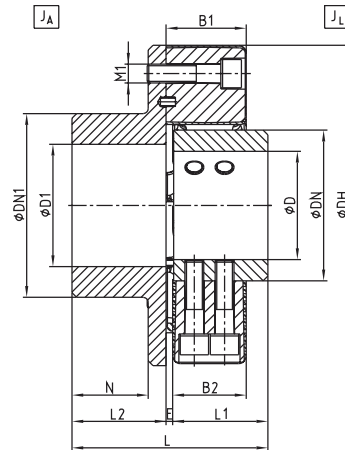

Size 360 - 560

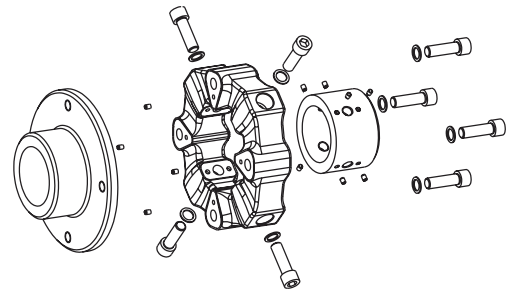

EVOLASTIC® type E2H																	
Size	Dimensions [mm]													Mass moment of inertia [kgm <sup>2</sup> ] <sup>1)</sup>		Weight [kg] <sup>1)</sup>	
	Max. finish bore		DH	DN	DN1	B1	B2	E	N	L	L1	L2	M1	JA	JL		
	D	D1															
12	38	55	122	60	80	32	28	4	32	88	42	42	M10	0.0030	0.0010	2.38	
24	46	70	150	70	100	42	36	6	38	106	50	50	M12	0.0081	0.0021	4.22	
32	46	70	150	70	100	42	36	6	38	106	50	50	M12	0.0090	0.0030	4.40	
48	55	85	170	85	115	46	40	6	41	116	55	55	M14	0.0160	0.0050	6.21	
60	65	100	200	100	140	58	50	8	50	140	66	66	M16	0.0360	0.0110	10.39	
86	65	100	200	100	140	58	50	8	50	140	66	66	M16	0.0370	0.0120	10.83	
125	85	110	260	125	160	70	63	7	60	168	80	80	M20	0.1110	0.0340	20.17	
200	85	110	260	125	160	70	63	7	60	168	80	80	M20	0.1160	0.0400	21.15	
280	105	110	300	145	160	80	72	8	70	192	94	90	M20	0.1960	0.0730	28.30	
360	115	130	340	160	195	85	78	7	80	208	100	100	M20	0.3540	0.1320	40.66	
560	120	140	370	170	200	105	95	10	100	260	125	125	M24	0.5890	0.2080	56.56	

<sup>1)</sup> With max. bore

Ordering example:	EVOLASTIC® 48	E2H	SN	1.0	Ø52	1.0	Ø52
	Coupling size	Type	Elastomer type	Hub type	Finish bore	Hub type	Finish bore

# EVOLASTIC® EFH

## Highly flexible couplings

### flange-to-shaft connection



For legend of pictogram refer to flapper on the cover

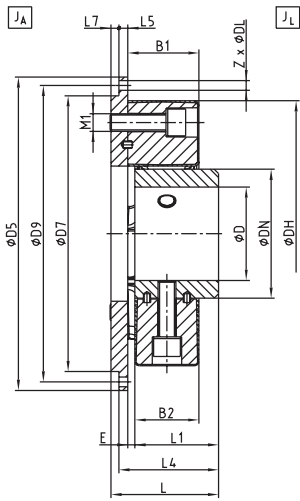

Size 12 - 280

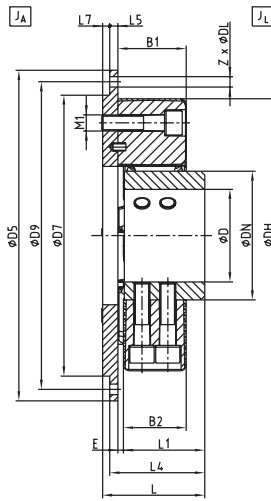

Size 360 - 560

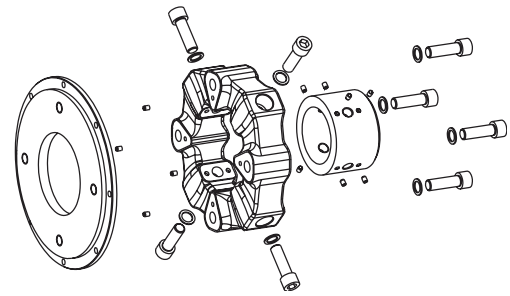

Flange dimensions according to SAE J620 [mm]				
Size	D5	D9	Z	DL
6 1/2"	215.90	200.02	6	9
7 1/2"	241.30	222.25	8	9
8"	263.52	244.47	6	11
10"	314.32	295.27	8	11
11 1/2"	352.42	333.37	8	11
14"	466.72	438.15	8	13

EVOLASTIC® type EFH																							
Size	Flange connection acc. to SAE - J620						Dimensions [mm]													Mass moment of inertia [kgm <sup>2</sup> ] <sup>1)</sup>		Weight [kg] <sup>1)</sup>	
	6.5"	7.5"	8"	10"	11.5"	14"	Max. finish bore D	DH	DN	B1	B2	E	L	L1	L4	L5	L7	M1	D7	JA	JL		
	12	●	●					38	122	60	32	28	4	56	42	52	6	4	M10	180	0.013		0.001
																				190	0.020	0.001	3.78
24	●	●					46	150	70	42	36	6	68	50	62	6	6	M12	180	0.016	0.002	4.26	
																				190	0.023	0.002	4.82
32	●	●					46	150	70	42	36	6	68	50	62	6	6	M12	180	0.016	0.003	4.44	
																				190	0.023	0.003	5.00
48		●	●				55	170	85	46	40	6	75	55	67	6	8	M14	190	0.026	0.005	6.03	
															71	10	4		200	0.034	0.005	6.62	
																				260	0.091	0.005	9.91
60			●	●			65	200	100	58	50	8	90	66	84	10	6	M16	270	0.103	0.011	12.07	
																				310	0.165	0.011	14.49
86			●	●			65	200	100	58	50	8	90	66	84	10	6	M16	270	0.105	0.012	12.52	
																				360	0.166	0.012	14.94
125			●	●			85	260	125	70	63	7	107	80	98	10	9	M16	270	0.129	0.034	16.72	
																				310	0.199	0.034	19.57
200			●	●			85	260	125	70	63	7	107	80	98	10	9	M20	270	0.135	0.039	17.64	
																				310	0.205	0.039	20.50
																				405	0.572	0.039	30.01
280			●	●			105	300	145	80	72	8	121	94	112	10	9	M20	310	0.226	0.072	23.54	
																				405	0.593	0.072	33.05
360			●	●			115	340	160	85	78	7	127	100	118	10	9	M20	405	0.628	0.130	37.55	
560			●	●			120	363	170	105	95	10	160	125	145	10	15	M24	405	0.794	0.203	49.06	

<sup>1)</sup> With max. bore

Ordering example:	EVOLASTIC® 48	EFH	SN	8	1.0	Ø52
	Coupling size	Type	Elastomer type	Flange ØDA acc. to SAE or special	Hub type	Finish bore

# EVOLASTIC® EP

## Highly flexible couplings

Pluggable elastomer - available in various kinds of Shore hardness



For legend of pictogram refer to flapper on the cover

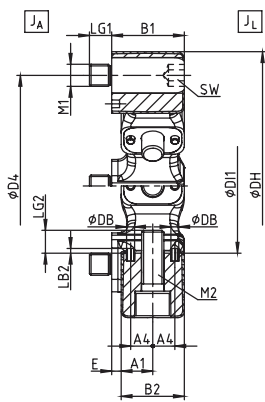

Size 12 - 280

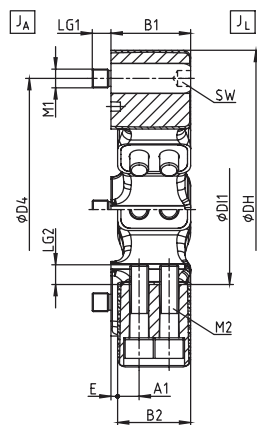

Size 360

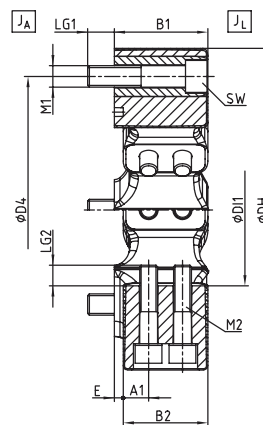

Size 560

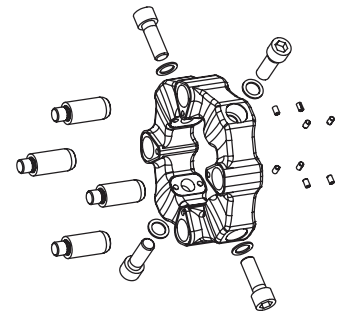

EVOLASTIC® type EP															
Size	Dimensions [mm]												Mass moment of inertia [kgm <sup>2</sup> ]		Weight [kg]
	DH	DI1	B1	B2	E	D4	Z x Pitch	LG	DB	A1	A4	LB2	J <sub>A</sub>	J <sub>L</sub>	
	12	122	60	32	28	4	100	3 x 120°	10	4	14.0	10.0	-	0.001	
24	150	70	42	36	6	125	3 x 120°	12	5	18.0	13.5	5	0.002	0.001	1.03
32	150	70	42	36	6	125	4 x 90°	12	5	18.0	13.5	5	0.003	0.002	1.26
48	170	85	46	40	6	140	4 x 90°	14	5	20.0	14.0	5	0.005	0.003	1.74
60	200	100	58	50	8	165	3 x 120°	16	5	25.0	18.0	5	0.009	0.007	1.52
86	200	100	58	50	8	165	4 x 90°	16	5	25.0	18.0	5	0.010	0.008	3.08
125	260	125	70	63	7	215	3 x 120°	20	8	31.5	22.5	5	0.028	0.022	5.16
200	260	125	70	63	7	215	4 x 90°	20	8	31.5	22.5	5	0.036	0.028	6.35
280	300	145	80	72	8	250	4 x 90°	20	8	36.0	22.5	5	0.068	0.050	8.71
360	340	160	85	78	7	280	4 x 90°	20	-	2 x 23.0	-	-	0.110	0.096	12.21
560	363	170	105	95	10	300	4 x 90°	30	-	2 x 28.5	-	-	0.203	0.145	17.67

### Delivery condition:

EVOLASTIC® couplings type EP are supplied with a mounting kit consisting of cap screws, screw locking washers, locking pins and positioning sleeves. With the connection design make sure sufficient screw-in depth. For the locking pin provide for an adhesive (e. g. Loctite® 243).

Size	Pin			Cap screw radial DIN EN ISO 4762 - 12.9	
	M1 / axial	SW	Tightening torque [Nm]	M2 / radial	Tightening torque [Nm]
12	M10	8	71	M10 x 30	71
24	M12	10	123	M12 x 35	123
32	M12	10	123	M12 x 35	123
48	M14	12	195	M14 x 40	195
60	M16	14	302	M16 x 50	302
86	M16	14	302	M16 x 50	302
125	M20	17	592	M20 x 65	592
200	M20	17	592	M20 x 65	592
280	M20	17	592	M20 x 65	592
360	M20	17	592	M20 x 80	592
560	M24	19	1017	M20 x 90	592

Ordering example:	EVOLASTIC® 48	EP	SN
	Coupling size	Type	Elastomer type

# EVOLASTIC® EHP

## Highly flexible couplings

Pluggable elastomer + shaft connection



For legend of pictogram refer to flapper on the cover

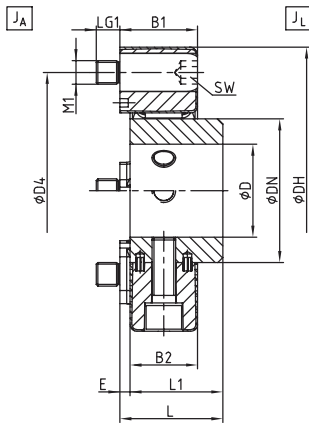

Size 12 - 280

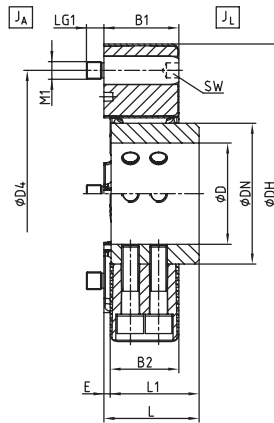

Size 360

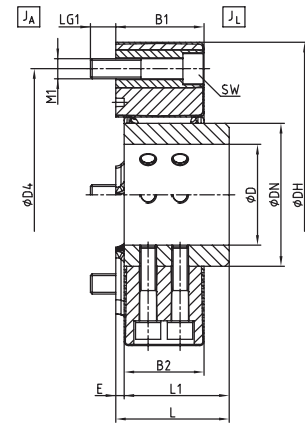

Size 560

EVOLASTIC® type EHP																
Size	Dimensions [mm]												Mass moment of inertia [kgm <sup>2</sup> ] <sup>1)</sup>		Weight [kg] <sup>1)</sup>	
	Max. finish bore D	DH	DN	B1	B2	E	L	L1	D4	Z x Pitch	LG	M1	SW	JA		JL
	12	38	122	60	32	28	4	46	42	100	3 x 120°	10	M10	8		0.001
24	46	150	70	42	36	6	56	50	125	3 x 120°	12	M12	10	0.002	0.002	1.85
32	46	150	70	42	36	6	56	50	125	4 x 90°	12	M12	10	0.003	0.003	2.08
48	55	170	85	46	40	6	61	55	140	4 x 90°	14	M14	12	0.004	0.005	3.07
60	65	200	100	58	50	8	74	66	165	3 x 120°	16	M16	14	0.009	0.010	4.79
86	65	200	100	58	50	8	74	66	165	4 x 90°	16	M16	14	0.010	0.012	5.32
125	85	260	125	70	63	7	88	80	215	3 x 120°	20	M20	17	0.028	0.024	9.15
200	85	260	125	70	63	7	88	80	215	4 x 90°	20	M20	17	0.036	0.039	10.30
280	105	300	145	80	72	8	102	94	250	4 x 90°	20	M20	17	0.068	0.076	14.29
360	115	340	160	85	78	7	108	100	280	4 x 90°	20	M20	17	0.110	0.131	19.44
560	120	363	170	105	95	10	135	125	300	4 x 90°	30	M24	19	0.203	0.203	28.41

<sup>1)</sup> With max. bore

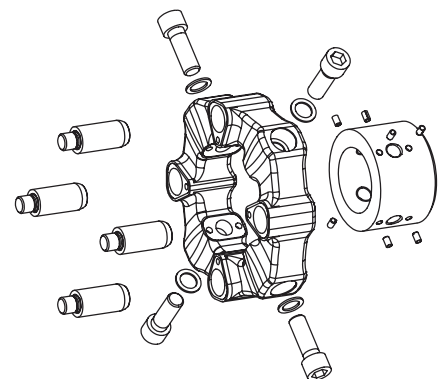

Ordering example:	EVOLASTIC® 48	EHP	SN	1.0	Ø52
	Coupling size	Type	Elastomer type	Hub type	Finish bore

EVOLASTIC®

Highly flexible shaft couplings

BoWex-ELASTIC® HEW Compact

# EVOLASTIC® E2HP

## Highly flexible couplings

### Shaft-to-shaft connection, plug-in



For legend of pictogram refer to flapper on the cover

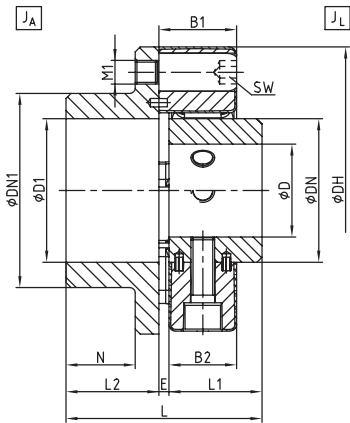

Size 12 - 280

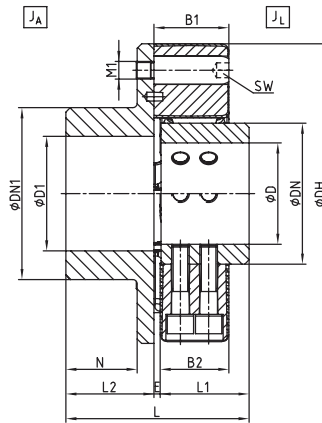

Size 360

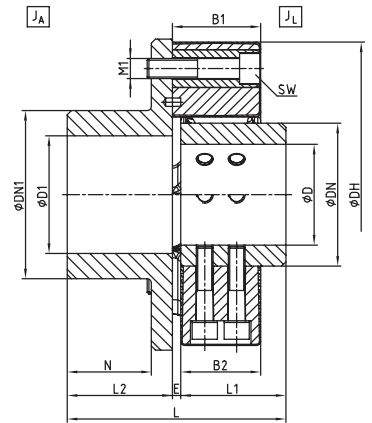

Size 560

EVOLASTIC® type E2HP																		
Size	Dimensions [mm]														Mass moment of inertia [kgm <sup>2</sup> ] <sup>1)</sup>		Weight [kg] <sup>1)</sup>	
	Max. finish bore		DH	DN	DN1	B1	B2	E	N	L	L1	L2	M1	SW	JA	JL		
	D	D1																
12	38	55	122	60	80	32	28	4	32	88	42	42	M10	8	0.003	0.001	2.44	
24	46	70	150	70	100	42	36	6	38	106	50	50	M12	10	0.009	0.002	4.26	
32	46	70	150	70	100	42	36	6	38	105	50	50	M12	10	0.009	0.003	4.53	
48	55	85	170	85	115	46	40	6	41	116	55	55	M14	12	0.016	0.005	6.41	
60	65	100	200	100	140	58	50	8	50	140	66	66	M16	14	0.038	0.010	10.62	
86	65	100	200	100	140	58	50	8	50	140	66	66	M16	14	0.039	0.012	11.13	
125	85	110	260	125	160	70	63	7	60	168	80	80	M20	17	0.115	0.034	20.55	
200	85	110	260	125	160	70	63	7	60	168	80	80	M20	17	0.123	0.039	21.65	
280	105	110	300	145	160	80	72	8	70	192	94	90	M20	17	0.208	0.073	29.05	
360	115	130	340	160	195	85	78	7	80	208	100	100	M20	17	0.368	0.104	41.25	
560	120	140	363	170	200	105	95	10	100	260	125	125	M24	19	0.640	0.203	58.62	

<sup>1)</sup> With max. bore

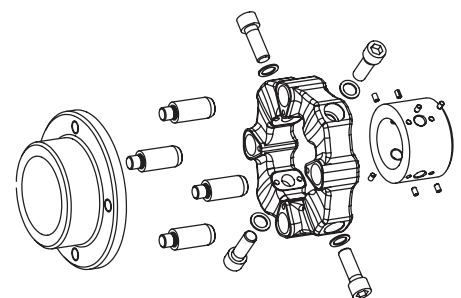

Ordering example:	EVOLASTIC® 48	E2HP	SN	1.0	Ø52	1.0	Ø52
	Coupling size	Type	Elastomer type	Hub type	Finish bore	Hub type	Finish bore

# EVOLASTIC® EFHP

## Highly flexible couplings

Flange-to-shaft connection, pluggable



For legend of pictogram refer to flapper on the cover

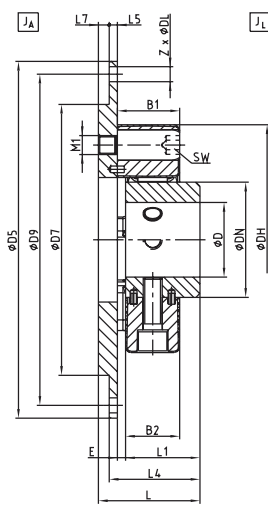

Size 12 - 280

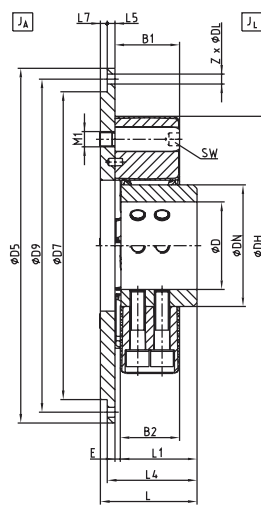

Size 360

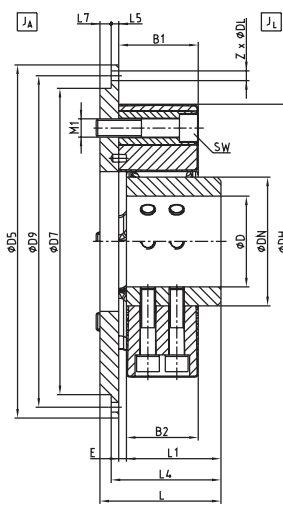

Size 560

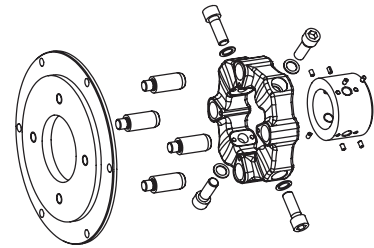

Flange dimensions according to SAE J620 [mm]				
Size	D5	D9	Z	DL
6 1/2"	215.90	200.02	6	9
7 1/2"	241.30	222.25	8	9
8"	263.52	244.47	6	11
10"	314.32	295.27	8	11
11 1/2"	352.42	333.37	8	11
14"	466.72	438.15	8	13

EVOLASTIC® type EFHP																							
Size	Flange connection acc. to SAE - J620						Dimensions [mm]													Mass moment of inertia [kgm <sup>2</sup> ] <sup>1)</sup>		Weight [kg] <sup>1)</sup>	
	6.5"	7.5"	8"	10"	11.5"	14"	Max. finish bore D	DH	DN	B1	B2	E	L	L1	L4	L5	L7	M1	SW	D7	J <sub>A</sub>		J <sub>L</sub>
12	●						38	122	60	32	28	4	56	42	52	6	4	M10	8	180	0.014	0.001	3.33
		●																		190	0.020	0.001	3.84
24	●	●					46	150	70	42	36	6	68	50	62	6	6	M12	10	180	0.016	0.002	4.30
			●																	190	0.249	0.002	4.86
32	●	●					46	150	70	42	36	6	68	50	62	6	6	M12	10	180	0.017	0.003	4.57
			●																	190	0.024	0.003	5.13
48			●				55	170	85	46	40	6	75	55	67	6	8	M14	12	190	0.027	0.005	6.20
				●											71	10	4			200	0.035	0.005	6.80
60				●			65	200	100	58	50	8	90	66	84	10	6	M16	14	270	0.105	0.011	12.30
					●															310	0.166	0.011	14.73
86				●			65	200	100	58	50	8	90	66	84	10	6	M16	14	270	0.107	0.012	12.82
					●															310	0.168	0.012	15.24
125				●			85	260	125	70	63	7	107	80	98	10	9	M20	17	270	0.134	0.034	17.10
					●															310	0.204	0.034	19.95
200				●			85	260	125	70	63	7	107	80	98	10	9	M20	17	270	0.141	0.039	18.20
					●															405	0.578	0.039	30.57
280				●			105	300	145	80	72	8	121	94	112	10	9	M20	17	310	0.239	0.072	24.35
					●															405	0.606	0.072	33.87
360					●		115	340	160	85	78	7	127	100	118	10	9	M20	17	405	0.642	0.130	38.25
560						●	120	363	170	105	95	10	160	125	145	10	15	M24	19	405	0.847	0.203	51.35

<sup>1)</sup> With max. bore

Ordering example:	EVOLASTIC® 48	EFHP	SN	8	1.0	Ø55
	Coupling size	Type	Elastomer type	Flange ØDA acc. to SAE or special	Hub type	Finish bore

EVOLASTIC®

Highly flexible shaft couplings

BoWex-ELASTIC® HEW Compact

# EVOLASTIC® D2H

## Highly flexible couplings

### Double-cardanic shaft-to-shaft connection

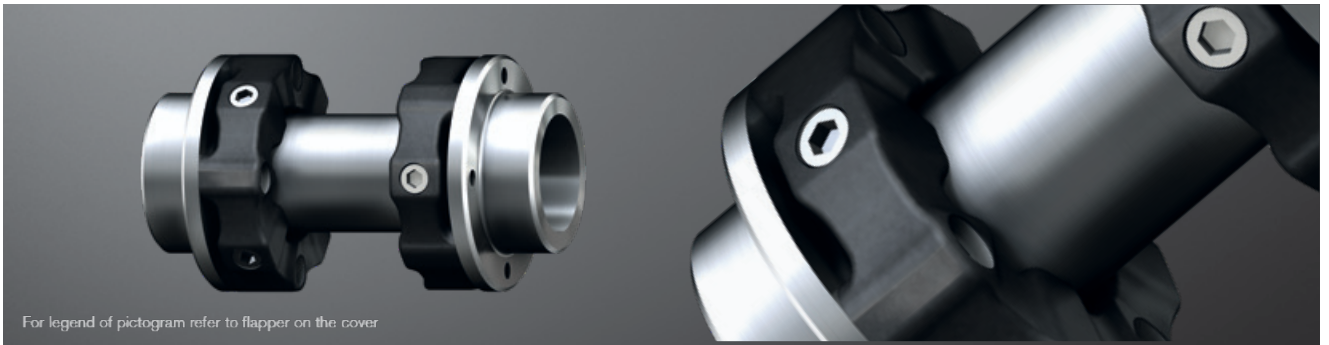

For legend of pictogram refer to flapper on the cover

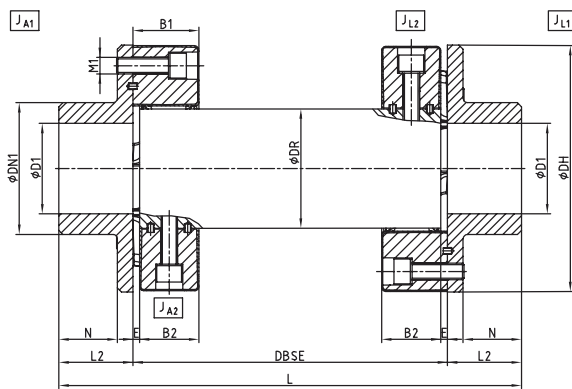

Size 12 - 280

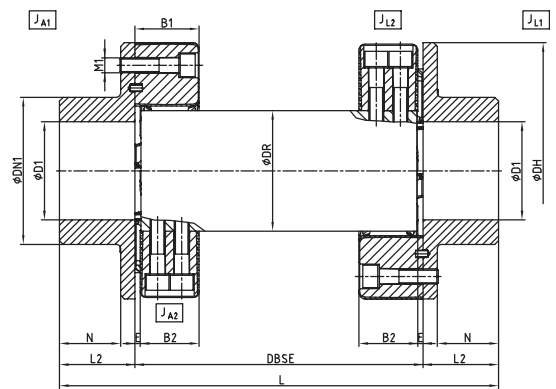

Size 360 - 560

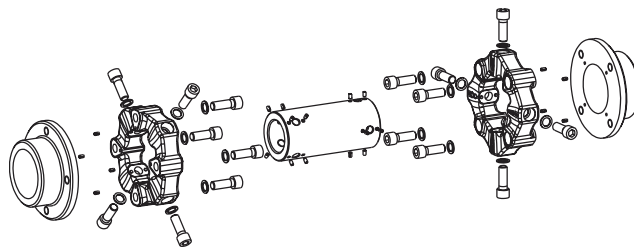

EVOLASTIC® type D2H												
Size	Dimensions [mm]										Mass moment of inertia [kgm <sup>2</sup> ] <sup>1)</sup>	
	Max. finish bore D1	DH	DN1	DR	B1	B2	E	L2	N	M1	JA1	JL1
12	55	122	80	60	32	28	4	42	32	M10	0.003	0.003
24	70	150	100	70	42	36	6	50	38	M12	0.008	0.008
32	70	150	100	70	42	36	6	50	38	M12	0.009	0.009
48	85	170	115	85	46	40	6	55	41	M14	0.016	0.016
60	100	200	140	100	58	50	8	66	50	M16	0.036	0.036
86	100	200	140	100	58	50	8	66	50	M16	0.037	0.037
125	110	260	160	125	70	63	7	80	60	M20	0.111	0.111
200	110	260	160	125	70	63	7	80	60	M20	0.116	0.116
280	110	300	160	145	80	72	8	94	70	M20	0.196	0.196
360	130	340	195	160	85	78	7	100	80	M20	0.354	0.354
560	140	370	200	170	105	95	10	125	100	M24	0.589	0.589

<sup>1)</sup> With max. bore  
Dimension L and DBSE as well as total weight depend on the mounting length  
Mass moments JA2 and JL2 depend on the mounting length and are available on request

Ordering example:	EVOLASTIC® 48	D2H	140	SN	1.0	Ø52	1.0	Ø52
	Coupling size	Type	Shaft distance DBSE	Elastomer type	Hub type	Finish bore	Hub type	Finish bore

# EVOLASTIC® DFH

## Highly flexible couplings

### Double-cardanic flange-to-shaft connection

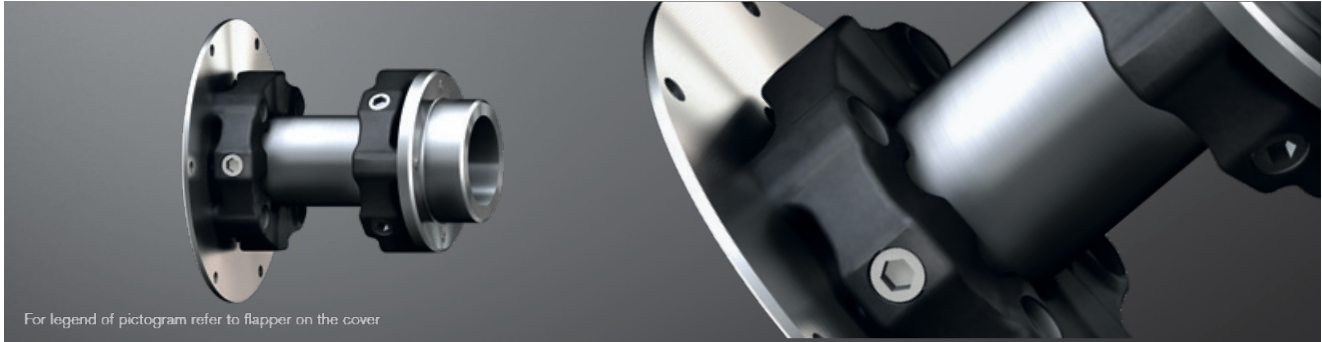

For legend of pictogram refer to flapper on the cover

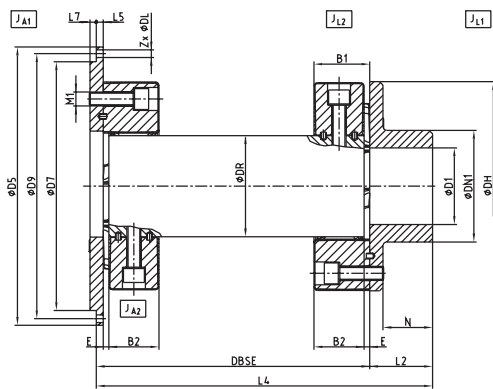

Size 12 - 280

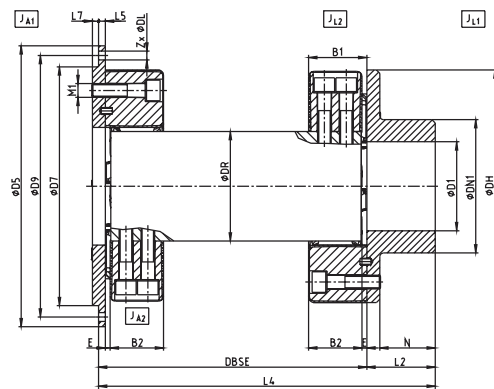

Size 360 - 560

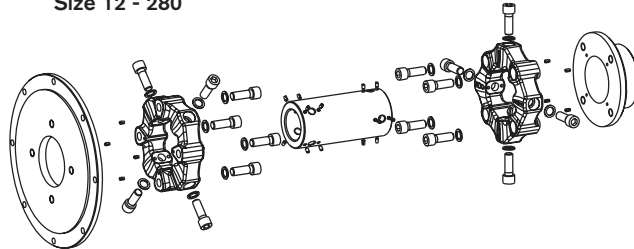

Flange dimensions according to SAE J620 [mm]				
Size	D5	D9	Z	DL
6 1/2"	215.90	200.02	6	9
7 1/2"	241.30	222.25	8	9
8"	263.52	244.47	6	11
10"	314.32	295.27	8	11
11 1/2"	352.42	333.37	8	11
14"	466.72	438.15	8	13

EVOLASTIC® type DFH																					
Size	Flange connection acc. to SAE - J620					Dimensions [mm]													Mass moment of inertia [kgm <sup>2</sup> ] <sup>1)</sup>		
	6.5"	7.5"	8"	10"	11.5"	14"	Max. finish bore D1	DH	DN1	DR	B1	B2	E	L2	L5	L7	N	M1	D7	JA1	JL1
12	●	●					55	122	80	60	32	28	4	42	6	4	32	M10	180 190	0.013 0.020	0.003
24	●	●					70	150	100	70	42	36	6	50	6	6	38	M12	180 190	0.016 0.023	0.008
32	●	●					70	150	100	70	42	36	6	50	6	6	38	M12	180 190	0.016 0.023	0.009
48		●	●				85	170	115	85	46	40	6	55	6	8	41	M14	190 200	0.026 0.034	0.016
60			●	●			100	200	140	100	58	50	8	66	10	6	50	M16	260 270	0.091 0.103	0.036
86				●	●		100	200	140	100	58	50	8	66	10	6	50	M16	310 270	0.165 0.166	0.037
125				●	●		110	260	160	125	70	63	7	80	10	9	60	M20	310 270	0.199 0.129	0.111
200				●	●		110	260	160	125	70	63	7	80	10	9	60	M20	405 310	0.572 0.135	0.116
280				●	●		110	300	160	145	80	72	8	94	10	9	70	M20	405 310	0.593 0.226	0.196
360				●	●		130	340	195	160	85	78	7	100	10	9	80	M20	405	0.628	0.354
560				●	●		140	370	200	170	105	95	10	125	10	15	100	M24	405	0.794	0.589

<sup>1)</sup> With max. bore  
Dimension L4 and DBSE as well as total weight depend on the mounting length  
Mass moments JA2 and JL2 depend on the mounting length and are available on request

Ordering example:	EVOLASTIC® 48	DFH	140	SN	8	1.0	Ø52
	Coupling size	Type	Shaft distance DBSE	Elastomer type	Flange ØDA acc. to SAE or special	Hub type	Finish bore

# BoWex-ELASTIC® HEW Compact Curved-tooth gear coupling®

Compensating for large displacements, very compact design



For legend of pictogram refer to flapper on the cover

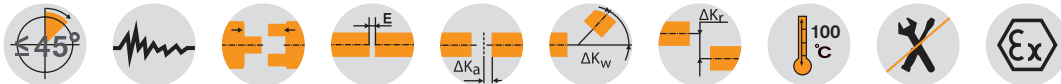

BoWex-ELASTIC® type HEW Compact																							
Size	Dimensions [mm]																			Weight with pilot bored coupling [kg]	Mass moment of inertia with pilot bored coupling [kgm²]		
	Max. finish bore		L		L1		L2	E		DA	DN	DN1	D4	D7	B1	NH	Z	M	JA		JL1	JL2	
	D	D1	HEW1	HEW2	HEW1	HEW2		HEW1	HEW2														
42-130	42	42	118	98	42	42	42	34	14	131	65	65	78	90	45	37	6	M6	3.4	0.003	0.001	0.001	
65-180	65	60	145	122	55	55	60	30	7	180	98	85	110	130	44	47	8	M10	9.0	0.014	0.006	0.006	
80-225	90	75	210	158	90	70	70	50	18	225	124	100	120	145	77	51	10	M12	18.9	0.035	0.029	0.021	
100-305	100	100	258	187	110	70	90	58	17	305	152	170	175	200	90	73	16	M12	40.2	0.152	0.087	0.068	
125-365	125	125	328	240	140	100	120	68	20	365	192	170	205	230	105	90	12	M16	75.0	0.360	0.260	0.192	

Technical data												
Coupling size	Elastomer hardness [Shore A]	Torque [Nm]			Perm. speed $n_{max}$ [rpm]	Perm. damping power			Dynamic torsion spring stiffness $C_{dyn}$ [Nm/rad]	Relative damping $\psi$	Resonance factor $V_R \approx 2 \cdot \Gamma / \psi$	Radial spring stiffness $C_r$ [N/mm]
		TKN	TK max.	with 10 Hz $T_{KW}$		PKW						
						60 °C	80 °C	90 °C				
42 HEW Compact	T50	200	400	50	7300	30	18	12	780	0.8	7.9	178
	T65	270	540	68					2400	1.2	5.2	600
	T70	320	640	80					2900	1.2	5.2	710
65 HEW Compact	T50	550	1100	138	5500	55	33	22	2850	0.8	7.9	379
	T65	740	1500	185					7800	1.2	5.2	955
	T70	860	1700	215					9500	1.2	5.2	1240
80 HEW Compact	T50	1250	2500	313	4400	90	54	36	5000	0.8	7.9	420
	T65	1600	3200	400					13000	1.2	5.2	1090
	T70	1900	3800	475					16500	1.2	5.2	1450
100 HEW Compact	T50	2750	5500	688	3200	150	90	60	17000	0.8	7.9	760
	T65	3900	7800	975					44000	1.2	5.2	1850
	T70	4500	9000	1125					50000	1.2	5.2	2250
125 HEW Compact	T50	5500	11000	1375	2900	220	132	88	25000	0.8	7.9	750
	T65	7500	15000	1875					62000	1.2	5.2	1930
	T70	8400	16800	2100					70000	1.2	5.2	2300

Ordering example:	BoWex® 65 HEW Compact	T50	d <sub>1</sub> Ø40	d <sub>2</sub> Ø65
	Size and type of coupling	Elastomer hardness	Finish bore H7 keyway to DIN 6885 sheet 1 (JS9)	Finish bore H7 keyway to DIN 6885 sheet 1 (JS9)

BoWex-ELASTIC® HEW1 Compact

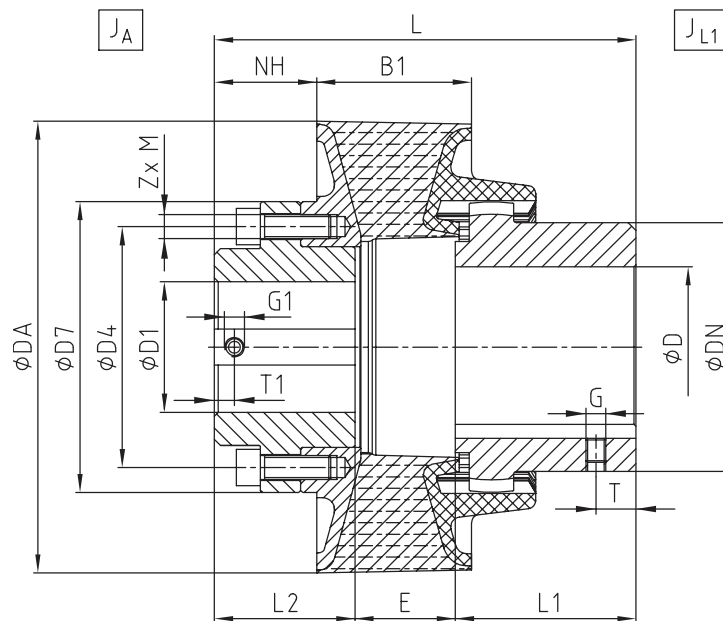

BoWex-ELASTIC® HEW2 Compact (with reduced hub)

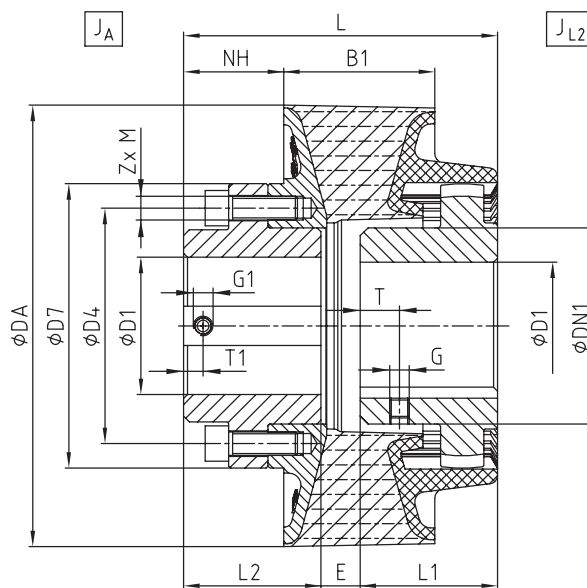

Displacements – type HEW Compact															
BoWex-ELASTIC® size	42-130			65-180			80-225			100-305			125-365		
Elastomer hardness [Shore A]	T50	T65	T70	T50	T65	T70	T50	T65	T70	T50	T65	T70	T50	T65	T70
Max. axial displacement $\Delta K_a$ [mm]	$\pm 2$			$\pm 2$			$\pm 2$			$\pm 2$			$\pm 2$		
Max. radial displacement with $n=1500$ rpm $\Delta K_r$ [mm]	$\pm 1.1$	$\pm 1$	$\pm 0.5$	$\pm 1.6$	$\pm 1.5$	$\pm 0.7$	$\pm 1.8$	$\pm 1.7$	$\pm 0.8$	$\pm 2.2$	$\pm 2$	$\pm 1$	$\pm 2.5$	$\pm 2.3$	$\pm 1.1$
Max. radial displacement with $n=3000$ rpm $\Delta K_r$ [mm]	$\pm 0.55$	$\pm 0.5$	$\pm 0.25$	$\pm 0.8$	$\pm 0.75$	$\pm 0.35$	$\pm 0.9$	$\pm 0.85$	$\pm 0.5$	$\pm 1.1$	$\pm 1$	$\pm 0.5$	$\pm 1.25$	$\pm 1.15$	$\pm 0.55$
Max. angular displacement with $n=1500$ rpm $\Delta K_w$ [degree]	$\pm 1$	$\pm 0.75$	$\pm 0.5$	$\pm 1$	$\pm 0.75$	$\pm 0.5$	$\pm 1$	$\pm 0.75$	$\pm 0.4$	$\pm 1$	$\pm 0.75$	$\pm 0.5$	$\pm 1$	$\pm 0.75$	$\pm 0.5$
Max. angular displacement with $n=3000$ rpm $\Delta K_w$ [degree]	$\pm 0.5$	$\pm 0.4$	$\pm 0.25$	$\pm 0.5$	$\pm 0.4$	$\pm 0.25$	$\pm 0.5$	$\pm 0.4$	$\pm 0.5$	$\pm 0.5$	$\pm 0.25$	$\pm 0.25$	$\pm 0.5$	$\pm 0.4$	$\pm 0.25$

EVOLASTIC®

Highly flexible shaft couplings

BoWex-ELASTIC® HEW Compact



# Flange couplings

Types and operating description 210

---

## BoWex®

BoWex® FLE-PA 212

BoWex® FLE-PAC 214

Selection according to SAE standard 216

Mounting dimensions according to SAE standard deviating from SAE standard 217

---

## MONOLASTIC®

Type with 3 holes 218

SAE type 219

---

## BoWex-ELASTIC®

Type HE1 - HE4 220

Type HE3, HE4 and HE-D 222

Type HE-ZS and HEW 224

Type HEG 226

---

## SINULASTIC®

Description of product and application 228

Properties of types by comparison 229

Technical data / materials 230

Type AK / AL 231

Type AKC / ALC 232

Type T 233

---

## VAROLASTIC®

Description of product and application 234

Types of hubs and displacements 235

Type F and FD 236

BoWex® FLE-PAC



MONOLASTIC®



BoWex-ELASTIC®



SINULASTIC®



VAROLASTIC®



# FLANGE COUPLINGS

## TYPES AND OPERATING DESCRIPTION

### Properties of flange couplings

Product	BoWex® FLE-PA/-PAC	MONOLASTIC®	BoWex-ELASTIC®	SINULASTIC®	VAROLASTIC®
Type	Torsionally stiff flange coupling	Flexible flange coupling	Highly flexible flange coupling	Highly flexible flange coupling	Highly flexible flange coupling with progressive characteristic
<b>Features</b>					
Torsionally stiff	●				
Torsionally flexible		●			●
Highly flexible			●	●	●
Damping vibrations		●	●	●	●
Maintenance-free	●	●	●	●	●
Axial plug-in	●	●	●	●	●
<b>Special features/applications</b>					
Variant diversity	very high	high	very high	very high (type A, B, T, V)	high
Flange dimension	SAE standard and special dimensions	type 3/4 hole, SAE standard and special dimensions	SAE standard and special dimensions	SAE standard and special dimensions	SAE standard and special dimensions
internal spline	see standard programme of BoWex® hubs	for SAE or DIN pump shafts	see standard programme of BoWex® hubs	Type B	see standard programme of hubs
Applications	hydrostatic drives of construction machines, agricultural machines, ...	hydrostatic drives of construction machines, agricultural machines, ...	generators, splitterboxes, water pumps, piston compressors, agricultural machines, mill drives, separator drives, ...	generators, gensets, splitterboxes, traction drives, hydraulic pumps, piston compressors, ...	Main drives in mechanical and plant engineering
<b>Performance data</b>					
Max. rated torque $T_{KN}$ [Nm]	6,600	1,850	70,000	25,000	8000
Max. speed n [rpm]	6,000	6,000	6,200	3,800	5,000
<b>Flange (standard and special)</b>					
Material	fibre-glass reinforced polyamide (PA)	natural rubber	natural rubber	natural rubber, EPDM, silicone	EPDM
	combination of polyamide with carbon fibre share and steel flange (PAC)				
Elastomer hardness	torsionally stiff	65, 70 Shore A	various kinds of hardness for vibration adaptation of drives	miscellaneous: S, M, H, U	HE / UE
<b>Flange (standard)</b>					
Temperature range [°C] min./max.	-25 / +130 (PA)	-40 / +100	-40 / +100	-40 / +120	-30 / +120
	-25 / +130 (PAC)				
<b>Engine power [kW]</b>					
Max.	800	250	5,000	3,500	1500

● ≈ Standard

○ ≈ On request

\* ≈ Depending on size

# FLANGE COUPLINGS

## TYPES AND OPERATING DESCRIPTION

### Product finder of flange couplings

Product	BoWex® FLE-PA/-PAC	MONOLASTIC®	BoWex-ELASTIC®	SINULASTIC®	VAROLASTIC®
Type	Torsionally stiff flange coupling	Flexible flange coupling	Highly flexible flange coupling	Highly flexible flange coupling	highly flexible flange coupling with progressive torsion spring stiffness
<b>Geometries</b>					
Design	extremely short	short	short	short	short
max. radial displacement	0.5 mm	1 mm	9.5 mm	3 mm	0.3 mm
shaft diameter min./max. [mm]	20 / 125	20 / 60	21 / 275	20 / 240	20 / 110
<b>Types (extract)</b>					
Intermediate shaft types » bridging larger shaft distances	–	–	HE-ZS	–	–
shaft-to-shaft connection	–	–	HEW1 and HEW2, HEW-ZS	○	–
flange-to-shaft connection	Standard	Standard	HE1, HE2, HE3 and HE4, HE-ZS	●	●
For cardan shafts » connecting coupling for I. C.-engines	–	–	HEG1 and HEG2	○	○
Combination with pump mounting flange	●	●	●	●	●
<b>Certifications / type examinations</b>					
ATEX			●	○	○
UL-listed	●		●	○	○
GOST R/GOST TR			●	○	○
DNV/GL	●	●	●	○	○
ABS					○
Bureau Veritas					○
LR					○
RS CLASS					○
CCS					○
ClassNK					○

● ≈ Standard  
○ ≈ On request  
\* ≈ Depending on size

### Please note: Pump mounting flanges



For connecting hydraulic pumps to the diesel engine, KTR supplies mounting flanges according to SAE connection dimensions sizes SAE 6 to SAE 1. These flanges are made of steel and EN-GJL-250 for hydraulic pumps with flange connections according to SAE-A, -B, -C, -D and -E as types with 2 and 4 holes.

Pump connection housings made of EN-GJL-250 to be mounted directly to the back plate of the engine.

### Miscellaneous pump mounting flange designs

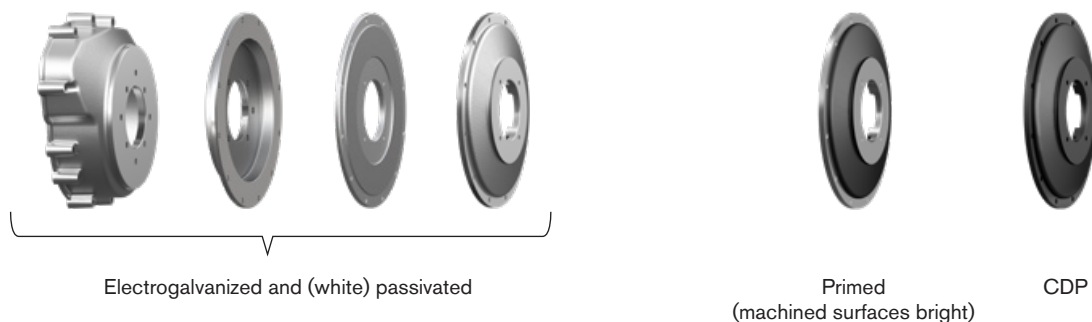

# BoWex® FLE-PA

## Torsionally stiff flange couplings

Axial plug-in, maintenance-free, torsionally stiff



For legend of pictogram refer to flapper on the cover

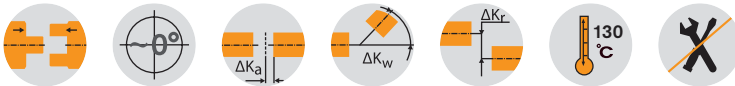

BoWex® FLE-PA – Dimensions/nominal dimension acc. to SAE																			
Size	Pilot bore	Finish bore d		Dimensions [mm]								Special length l1 max.	Nominal size acc. to SAE (Dg)						Max. axial displacement [mm]
		min.	max.	D	D1	I1	I3	I7	I8	I10	I11		6 1/2"	7 1/2"	8"	10"	11 1/2"	14"	
48	-	20	48	68	100	50	41	50	20	13	48	up to 60	●	●	●	●			± 2
T 48	13	15	48	68	100	50	38	45	20	13	46	-	●	●	●	●			± 1
T 55	17	20	55	85	115	50	37	48	24	13	48	-	●	●	●	●			± 2
65 / T 65	21	30	65	96	132	55	45	54	27	21	51	up to 70			●	●			± 2
T 70	26	30	70	100	153	60	48	56	30	21	57	-				●			± 2
80 / T 80	31	35	90	124	170	90	78	87	30	21	87	-				●	●		± 2
100 / T 100	38	40	100	152	265	110	78	108	35	21	110	-					●	●	± 2
125 / T 125	45	50	125	192	250	140	113	140	50	28	97	-					●	●	± 2

Technical data of BoWex® FLE-PA – Torques/weights/mass moments of inertia/torsion spring stiffness															
Size	Torque TK [Nm]			Weight/mass moment of inertia J	Hub with max. bore	FLE-PA flanges according to SAE						Dynamic torsion spring stiffness with +60 °C/ψ = 0.4 [Nm/rad]			
	TKN	TK max.	TKW			6 1/2"	7 1/2"	8"	10"	11 1/2"	14"	0.30 TKN	0.50 TKN	0.75 TKN	1.00 TKN
48	240	600	120	[kg]	0.79	0.32	0.43	0.51	0.64	-	-	35 x 10³	75 x 10³	105 x 10³	125 x 10³
				[kgm²]	0.0007	0.0021	0.0035	0.0049	0.0085	-	-	-	-	-	-
T 48	300	750	150	[kg]	0.79	0.32	0.43	0.51	0.64	-	-	40 x 10³	86 x 10³	120 x 10³	143 x 10³
				[kgm²]	0.0007	0.0021	0.0035	0.0049	0.0085	-	-	-	-	-	-
T 55	450	1125	225	[kg]	1.20	0.34	0.62	0.45	0.646	-	-	90 x 10³	140 x 10³	170 x 10³	195 x 10³
				[kgm²]	0.0016	0.0022	0.0053	0.0044	0.0086	-	-	-	-	-	-
65	650	1600	325	[kg]	1.50	-	-	0.63	0.64	0.89	-	110 x 10³	160 x 10³	200 x 10³	230 x 10³
				[kgm²]	0.0027	-	-	0.0064	0.0065	0.012	-	-	-	-	-
T 65	800	2000	400	[kg]	1.60	-	-	0.63	>0.90	>1.11	-	130 x 10³	190 x 10³	240 x 10³	280 x 10³
				[kgm²]	0.0035	-	-	0.0064	0.0065	0.012	-	-	-	-	-
T 70	1000	2500	500	[kg]	2.60	-	-	-	0.941	-	-	165 x 10³	315 x 10³	345 x 10³	368 x 10³
				[kgm²]	0.0059	-	-	-	0.0132	-	-	-	-	-	-
80	1200	3000	600	[kg]	5.20	-	-	-	1.05	1.12	-	200 x 10³	410 x 10³	580 x 10³	700 x 10³
				[kgm²]	0.0151	-	-	-	0.015	0.022	-	-	-	-	-
T 80	1500	3750	750	[kg]	5.20	-	-	-	1.05	1.12	-	240 x 10³	450 x 10³	638 x 10³	770 x 10³
				[kgm²]	0.0151	-	-	-	0.015	0.022	-	-	-	-	-
100	2050	5150	1025	[kg]	9.37	-	-	-	-	1.16	8.45	500 x 10³	700 x 10³	856 x 10³	950 x 10³
				[kgm²]	0.0401	-	-	-	-	0.021	0.234	-	-	-	-
T 100	2500	6250	1250	[kg]	9.37	-	-	-	-	1.16	8.45	600 x 10³	830 x 10³	960 x 10³	1070 x 10³
				[kgm²]	0.0401	-	-	-	-	0.021	0.234	-	-	-	-
125	4250	10700	2125	[kg]	19.73	-	-	-	-	2.09	9.85	1280 x 10³	1885 x 10³	2280 x 10³	2665 x 10³
				[kgm²]	0.1359	-	-	-	-	0.043	0.306	-	-	-	-
T 125	5300	13250	2650	[kg]	19.73	-	-	-	-	2.09	9.85	1600 x 10³	2250 x 10³	2700 x 10³	3200 x 10³
				[kgm²]	0.1359	-	-	-	-	0.043	0.306	-	-	-	-

Mounting procedure, screw type with property class, tightening torques as per KTR assembly instructions (see [www.ktr.com](http://www.ktr.com)).

Short mounting version

Long mounting version

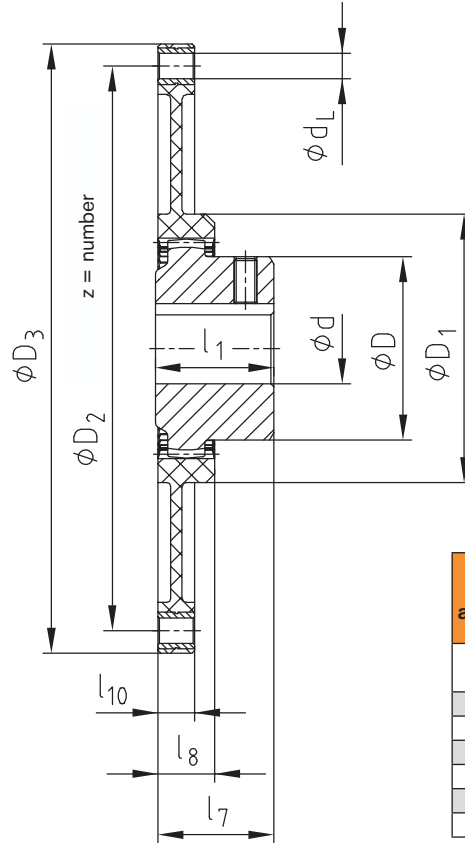
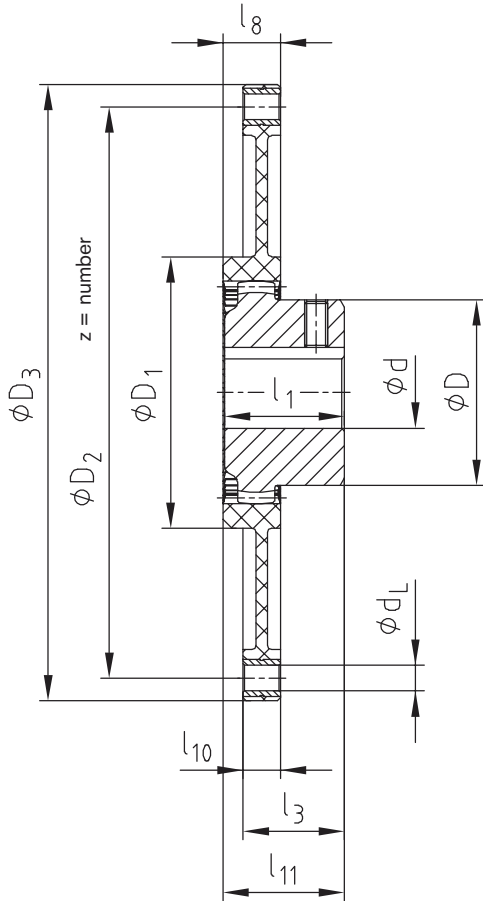

Flange dimensions according to SAE J620 [mm]				
Size	D <sub>3</sub>	D <sub>2</sub>	z	d <sub>L</sub>
6 1/2"	215.9	200.02	6	9
7 1/2"	241.3	222.25	8	9
8"	263.52	244.47	6	11
10"	314.32	295.27	8	11
11 1/2"	352.42	333.37	8	11
14"	466.72	438.15	8	13

Example of installation

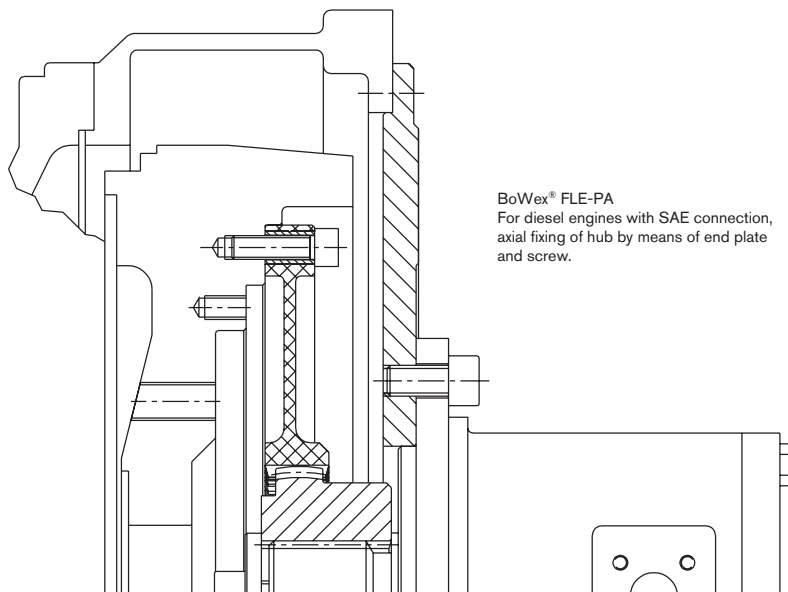

# BoWex® FLE-PAC

## Torsionally stiff flange couplings

Axial plug-in, extremely short design, carbon-fibre reinforced material



For legend of pictogram refer to flapper on the cover

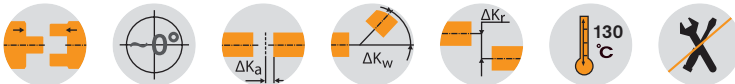

BoWex® FLE-PAC – Dimensions/nominal dimension acc. to SAE

Size	Pilot bore	Finish bore d		Dimensions [mm]							Special length l <sub>1</sub> max.	Nominal size acc. to SAE (D <sub>3</sub> )						Max. axial displacement [mm]
		min.	max.	D	D <sub>1</sub>	l <sub>1</sub>	l <sub>3</sub>	l <sub>7</sub>	l <sub>8</sub>	l <sub>10</sub>		6 1/2"	7 1/2"	8"	10"	11 1/2"	14"	
48 / T 48	13	15	48	68	110	50	35	46	25	3	up to 60	●	●	●	●			± 3
T 55	17	20	55	85	148	50	32	42	28	3	-	●	●	●	●			± 3
65 / T 65	21	30	65	96	165	55	36	46	32	4	up to 70	●	●	●	●	●		± 3
80 / T 80	31	35	90	124	220	90	72	76	35	4	-				●	●	●	± 3
100 / T 100	38	40	100	152	280	110	85	102	47	5	-					●	●	± 3
125 / T 125	45	50	125	192	250	140	113	140	50	28	-					●	●	± 3

Special flange dimensions deviating from SAE standard are also available.

Technical data of BoWex® FLE-PAC – Torques/weights/mass moments of inertia/torsion spring stiffness

Size	Torque T <sub>K</sub> [Nm]			Weight/mass moment of inertia J	Hub with max. bore	FLE-PAC flanges according to SAE						Dynamic torsion spring stiffness with +60 °C/ψ = 0.45 [Nm/rad]						
	T <sub>KN</sub>	T <sub>K max.</sub>	T <sub>KW</sub>			6 1/2"	7 1/2"	8"	10"	11 1/2"	14"	0.30 T <sub>KN</sub>	0.50 T <sub>KN</sub>	0.75 T <sub>KN</sub>	1.00 T <sub>KN</sub>			
48	300	600	150	[kg]	0.79	0.77	0.98	1.19	1.73									
				[kgm <sup>2</sup> ]	0.0007	0.0049	0.0077	0.0109	0.0221									
T 48	370	740	185	[kg]	0.79	0.77	0.98	1.19	1.73									
				[kgm <sup>2</sup> ]	0.0007	0.0049	0.0077	0.0109	0.0221									
T 55	550	1100	275	[kg]	1.20	0.74	0.95	1.16	1.7									
				[kgm <sup>2</sup> ]	0.0016	0.0049	0.0077	0.0109	0.0222									
65	800	1600	400	[kg]	1.50	0.93	1.2	1.48	2.20	2.83								
				[kgm <sup>2</sup> ]	0.0027	0.0065	0.0101	0.0145	0.0294	0.0467								
T 65	1000	2000	500	[kg]	1.60	0.93	1.2	1.48	2.20	2.83								
				[kgm <sup>2</sup> ]	0.0035	0.0065	0.0101	0.0145	0.0294	0.0467								
80	1500	3000	750	[kg]	5.20				2.27	2.90	5.20							
				[kgm <sup>2</sup> ]	0.0151				0.0312	0.0485	0.1462							
T 80	1850	3700	925	[kg]	5.20				2.27	2.90	5.20							
				[kgm <sup>2</sup> ]	0.0151				0.0312	0.0485	0.1462							
100	2550	5100	1275	[kg]	9.37				3.35	6.22								
				[kgm <sup>2</sup> ]	0.0401				0.0606	0.1828								
T 100	3100	6200	1550	[kg]	9.37				3.35	6.22								
				[kgm <sup>2</sup> ]	0.0401				0.0606	0.1828								
125	5350	10700	2675	[kg]	19.73				2.09	9.85								
				[kgm <sup>2</sup> ]	0.1359				0.043	0.306								
T 125	6600	13200	3300	[kg]	19.73				2.09	9.85								
				[kgm <sup>2</sup> ]	0.1359				0.043	0.306								

Mounting procedure, screw type with property class, tightening torques as per KTR assembly instructions (see [www.ktr.com](http://www.ktr.com)).

Short mounting version

Long mounting version

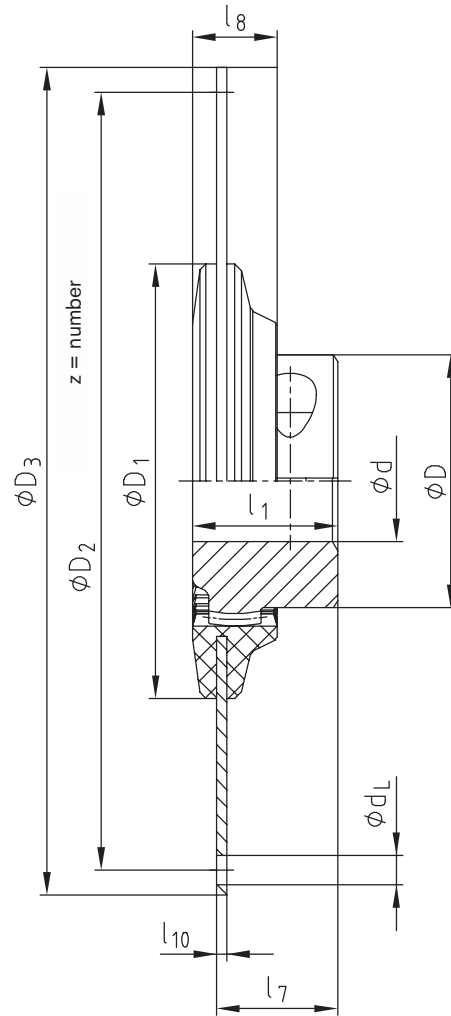
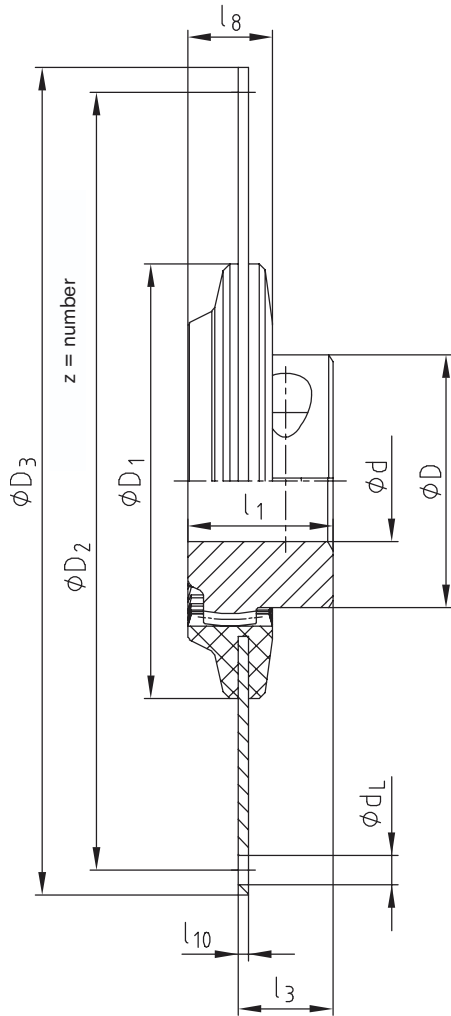

Flange dimensions according to SAE J620 [mm]				
Size	D <sub>3</sub>	D <sub>2</sub>	z	d <sub>L</sub>
6 1/2"	215.9	200.02	6	9
7 1/2"	241.3	222.25	8	9
8"	263.52	244.47	6	11
10"	314.32	295.27	8	11
11 1/2"	352.42	333.37	8	11
14"	466.72	438.15	8	14

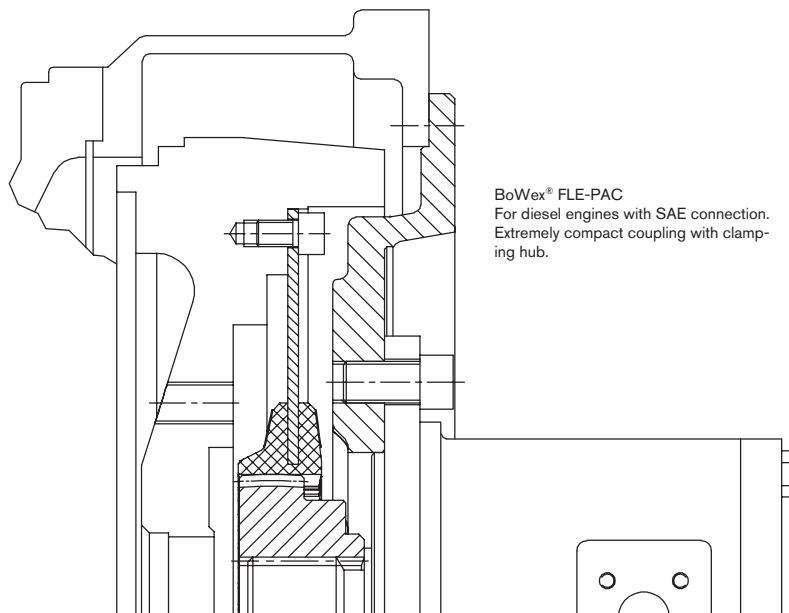

# BoWex® FLE-PA / FLE-PAC

## Torsionally stiff flange couplings

### Selection according to SAE standard

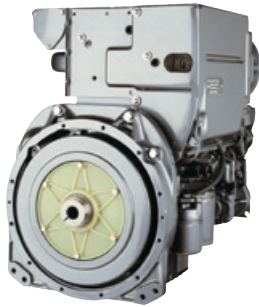

#### Determination of coupling

- Determination of coupling size
- Connection dimension of coupling
- Hub type/mounting length

- Table 1
- Table 2
- Table 3

#### SAE pump mounting flange

- Flange size according to SAE 617
- Connection flange of hydraulic pump

- Table 4
- Table 5

Short mounting version of coupling ( $l_3$ )

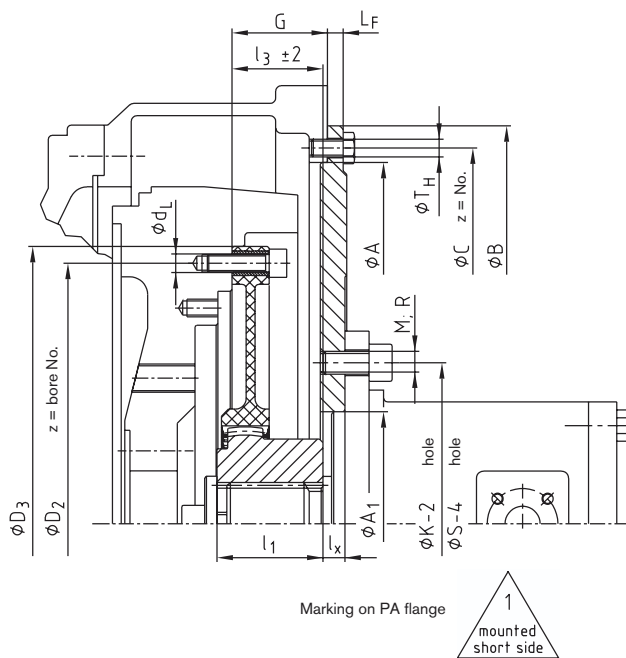

Long mounting version of coupling ( $l_7$ )

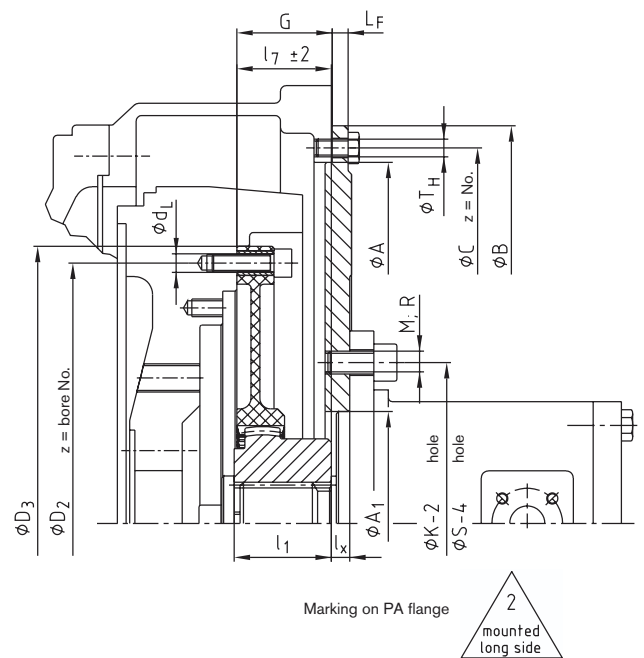

Spline hub

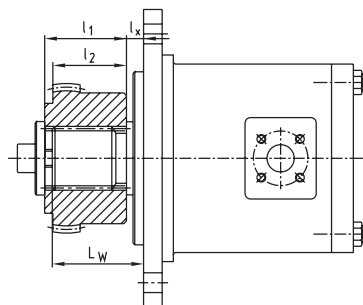

Clamping hub

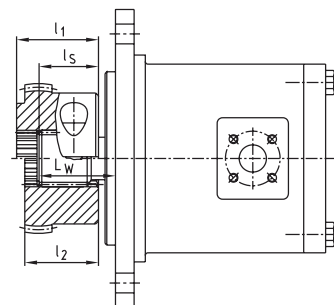

#### Calculation of mounting length $l_3$ or $l_7$

SAE shaft	$l_3 / l_7 = G + L_F - L_W + l_S$
DIN shaft	$l_3 / l_7 = G + L_F - l_X$

If axial fixing of the hub by means of an end plate and a screw is not possible for a pump shaft with involute spline, a clamping hub should be used.

#### Mounting instructions:

The flange can be fastened to the engine flywheel by means of socket head cap screws according to DIN EN ISO 4762 strength class 8.8 or by hexagon head screws strength class 8.8. We recommend screws are loctited in position.

#### Screw tightening torque of FLE-PA flange on the flywheel

M8	25 Nm
M10	49 Nm
M12	86 Nm

#### Screw tightening torque of spline clamping hubs DIN EN ISO 4762

42/48	M10	49 Nm
T55/65/T70	M12	86 Nm
80/100/125	M16	210 Nm

# BoWex® FLE-PA / FLE-PAC

## Torsionally stiff flange couplings

### Mounting dimensions according to SAE standard

1. Selection of coupling for diesel engine												
Diesel engine power		Coupling size	Flywheel acc. to SAE			Pump mounting flange		Driving shaft of pump				
kW	PS		G			LF						
up to 40	up to 55	48 FLE-PA	6 1/2"	30.15	1.19"	9.5	0.375"	See Table 3 hub type SAE J 498 / DIN 5480				
			7 1/2"	30.15	1.19"							
			8	62	2.44"							
up to 75	up to 100	T55 FLE-PA	6 1/2"	30.15	1.19"	9.5	0.375"		See Table 3 hub type SAE J 498 / DIN 5480			
			7 1/2"	30.15	1.19"							
			8	62	2.44"							
up to 90	up to 120	65 FLE-PA	10	54	2.12"	9.5	0.375"			See Table 3 hub type SAE J 498 / DIN 5480		
			10	54	2.12"							
			11 1/2"	39.6	1.56"							
up to 150	up to 200	T70 FLE-PA	10	54	2.12"	9.5	0.375"				See Table 3 hub type SAE J 498 / DIN 5480	
			10	54	2.12"							
up to 180	up to 240	80 FLE-PA	10	54	2.12"	9.5	0.375"					See Table 3 hub type SAE J 498 / DIN 5480
			11 1/2"	39.6	1.56"							
up to 285	380	100 FLE-PA	11 1/2"	39.6	1.56"	12.7	0.5"	See Table 3 hub type SAE J 498 / DIN 5480				
			14	25.4	1"							
up to 540	720	125 FLE-PA	11 1/2"	39.6	1.56"	12.7	0.5"		See Table 3 hub type SAE J 498 / DIN 5480			
			14	25.4	1"							

4. Housing dimensions according to SAE 617 [mm]						
SAE size	A	B	C	Z	TH	
SAE-1	511.18	552	530.2	12	M10	3/8"
SAE-2	447.68	489	466.7	12	M10	3/8"
SAE-3	409.58	451	428.6	12	M10	3/8"
SAE-4	361.95	403	381.0	12	M10	3/8"
SAE-5	314.33	356	333.4	8	M10	3/8"
SAE-6	266.7	308	285.7	8	M10	3/8"

5. Mounting flange for hydraulic pump acc. to SAE [mm]								
SAE size	SAE flange with 2 holes				SAE flange with 4 holes			
	A1	K-2	M	Z	A1	S-4	R	Z
A	82.55	106.4	M10 3/8"	2	82.55	104.6	M10 3/8"	4
B	101.6	146.0	M12 1/2"	2	101.6	127.0	M12 1/2"	4
C	127.0	181.0	M16 3/8"	2	127.0	162.0	M12 1/2"	4
D	152.4	228.6	M16 3/8"	2	152.4	228.6	M16 5/8"	4
E	-	-	-	-	165.1	317.5	M20 3/4"	4

2. Dimensions of coupling flange according to SAE J620 [mm]				
Nominal size	D3	D2	z = number	dL
6 1/2"	215.90	200.02	6	9
7 1/2"	241.30	222.25	8	9
8"	263.52	244.47	6	11
10"	314.32	295.27	8	11
11 1/2"	352.42	333.37	8	11
14"	466.72	438.15	8	14

3. Selection of coupling hubs - Calculation of mounting length l3 or l7															
BoWex® coupling size	Pump shaft to SAE J 498 and DIN 5480	Spine hub	Spine clamping hub	Dimensions of coupling hub [mm]			Mounting length of coupling l3 or l7								Code to order coupling hub Specify coupling size
							Flange size 6 1/2" and 7 1/2"		Flange size 8"		Flange size 10"		Flange size 11 1/2"		
				l1	l2	lS	K	L	K	L	K	L	K	L	
42	SAE-16/32 DP PI-S 3/4" z = 11	x	x	42	-	33	33	42							P559101
42	SAE-16/32 DP PB-S 1/8" z = 13	x	x	42	-	-	33	42							P567101
42	SAE-16/32 DP PB-BS 1" z = 15	x	x	42	-	27	33	42							P660201
48	SAE-16/32 DP	x	x	50	-	45	41	50	50	41	50				P663301
65	PA-S 1 3/8" z = 21	x	x	50	-	48			54	45	54	41			P663301
65	SAE-12/24 DP PC-S 1 1/4" z = 14	x	x	55	-	44			54	45	54	41			P656201
65	SAE-16/32 DP PD-S 1 1/2" z = 23	x	x	-	49	45					53	41			P664301
80	SAE-16/32 DP PE-S 1 3/4" z = 27	x	x	55	-	-						33	44		P665402
42	25 x 1.25 x 18	x	x	42	-	-	33	42							P000205
42	DIN 5480	x	x	42	-	-	33	42							P500202
42		x	x	42	-	-	33	42							P500203
48	30 x 2 x 14	x	x	50	-	-	41	50							P000206
48	DIN 5480	x	x	50	-	-	41	50	50		50				P500203
48		x	x	46	-	-	37	46							P000303
65	35 x 2 x 16	x	x	55	-	-					54	39			P000303
65	DIN 5480	x	x	60	-	-			50	59	50	59	39		P500301
65	40 x 2 x 18	x	x	55	-	-					54	39			P000304
65	DIN 5480	x	x	55	-	-			54	45	54	39			P500302
65	45 x 2 x 21	x	x	-	64	-			60	69	60	69	39		P000403
65	DIN 5480	x	x	55	-	-			54	45	54	39			P500401
80	50 x 2 x 24	x	x	55	-	-						37	42		P500405
	DIN 5480	x	x	55	-	-									

Shown above is a small overview of splines available, other SAE or DIN splines are also available. KTR splines are designed for shaft tolerances SAE class 5 resp. DIN 5480 9g.

Ordering example: Coupling FLE-PA/FLE-PAC			SAE pump mounting flange	
BoWex® 48 FLE-PA	7 1/2"	P663301	SAE-4	B-2L
Coupling size	SAE connection of coupling	Code of coupling hub	Pump mounting flange for engine housing	Pump flange acc. to SAE 2 holes/4 holes standard metric fastening thread
Table 1	Table 2	Table 3	Table 4	Table 5

# MONOLASTIC®

## One-piece, flexible flange couplings

Type with 3 holes (EP 0853203/U.S. Patent 6,117,017)



For legend of pictogram refer to flapper on the cover

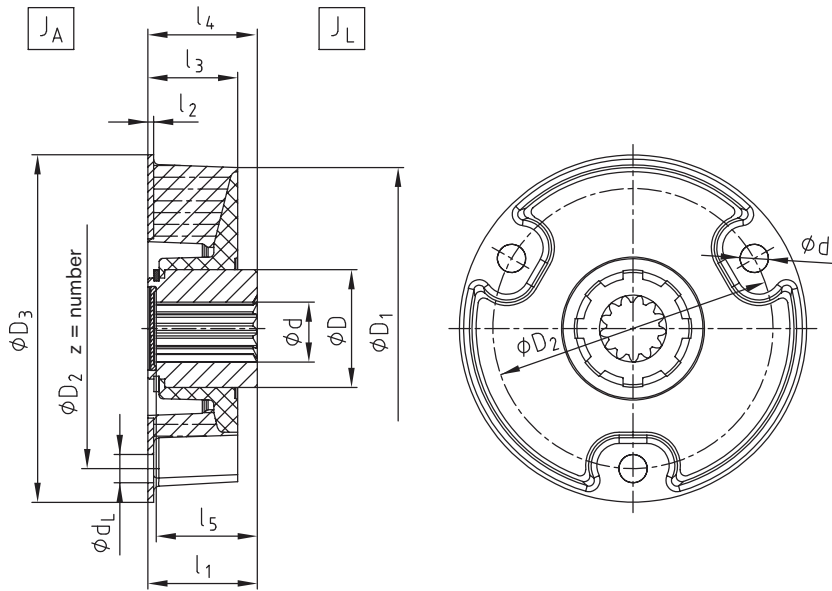
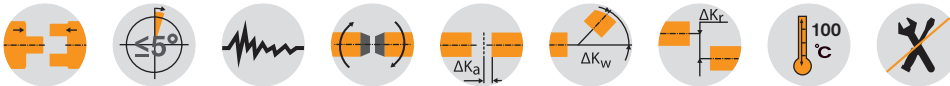

MONOLASTIC®																
Size	Elastomer hardness [Shore A]	Torque [Nm]			Dimensions [mm]											
		T <sub>KN</sub>	T <sub>K max.</sub>	T <sub>KW</sub>	d	D	D <sub>1</sub>	D <sub>2</sub>	z	d <sub>L</sub>	D <sub>3</sub>	l <sub>1</sub>	l <sub>2</sub>	l <sub>3</sub>	l <sub>4</sub>	l <sub>5</sub>
22	T65	40	100	20	20	34	93	80	3	8.10	100	33	1.5	32	34	30
	T65	70	175	35	25	42	115	100	3	10.10	124	40	2	32	40	38
28	T70	100	250	50	32	50	140	125	3	12.10	150	42	2	42	43	38
	T65	160	400	80	32	50	140	125	3	12.10	150	42	2	42	43	38
32	T70	225	562	112	32	50	140	125	3	12.10	150	42	2	42	43	38
	T70	260	650	130	32	50	167	140	3	14.10	175	46	3	35	46	43
50-140	T70	260	650	130	32	50	167	140	3	14.10	175	46	3	35	46	43
50-165	T70	300	750	150	32	50	175	165	3	16.15	200	46	3	35	46	43
50-170	T70	300	750	150	32	50	175	170	3	16.15	200	46	3	35	46	43
60-165	T70	400	1000	200	48	68	191	165	3	16.15	205	50	3	40	55	46

Technical data									
Size	Elastomer hardness [Shore A]	C <sub>dyn.</sub> with 60 °C [Nm/rad]	Perm. damping power with 60 °C P <sub>KW</sub> [W]	Max. displacement with 2200 rpm ΔK <sub>r</sub> [mm]	Perm. angular displacement with 2200 rpm ΔK <sub>w</sub> [°]	Radial spring stiffness C <sub>r</sub> [N/mm]	Mass moment of inertia [kgm <sup>2</sup> ]		Perm. operating speed n <sub>max.</sub> [rpm]
							JA	JL	
22	T65	600	10	0.6		200	0.00017	0.00010	6000
	T65	900	15	0.6		300	0.00054	0.00033	6000
28	T70	1300	25	0.5		400	0.00120	0.00081	6000
	T65	1800	25	0.6		400	0.00120	0.00081	6000
32	T70	2400	35	0.5	1	500	0.00210	0.00130	6000
	T70	4200	35	0.5	1	500	0.00210	0.00130	6000
50-140	T70	4200	35	0.5	1	1365	0.00210	0.00130	6000
50-165	T70	5600	40	0.5	1	1550	0.00250	0.00130	6000
50-170	T70	5600	40	0.5	1	1550	0.00250	0.00130	6000
60-165	T70	7800	40	0.5	1	1500	0.00599	0.00358	6000

The technical data specified apply for an ambient temperature of T = 60 °C.

# MONOLASTIC®

## One-piece, flexible flange couplings

Type SAE (EP 0853203/U.S. Patent 6,117,017)



For legend of pictogram refer to flapper on the cover

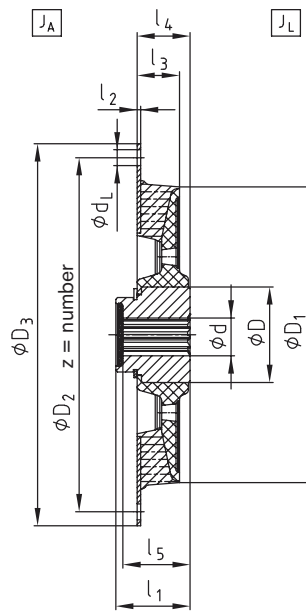
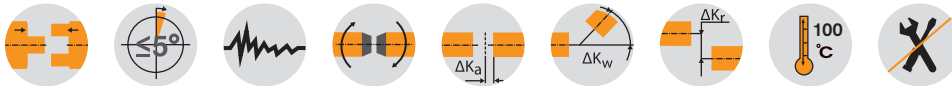

Flange dimensions according to SAE J620 [mm]

Size	D <sub>3</sub>	D <sub>2</sub>	z	d <sub>L</sub>
6 1/2"	215.9	200.02	6	9
7 1/2"	241.3	222.25	8	9
8"	263.52	244.47	6	11
10"	314.32	295.27	8	11
11 1/2"	352.42	333.37	8	11

MONOLASTIC®																		
Size	Elastomer hardness [Shore A]	Torque [Nm]			Dimensions [mm]									MONOLASTIC® flanges according to SAE				
		T <sub>KN</sub>	T <sub>K max.</sub>	T <sub>KW</sub>	d <sub>max.</sub>	D	D <sub>1</sub>	l <sub>1</sub>	l <sub>2</sub>	l <sub>3</sub>	l <sub>4</sub>	l <sub>5</sub>	6 1/2"	7 1/2"	8"	10"	11 1/2"	
30	T65	200	400	100	25	42	120	39	2	21	30	36	X	X				
	T70	250	500	125														
50	T65	350	700	175	32	50	167	42	2	24	30	38	X	X	X	X		
	T70	450	900	225														
G50	T70	600	1200	300	32	50	178	42	2	24	36	38		X	X	X		
65	T65	750	1500	375	48	68	200	45	3	32	45	42				X	X	
	T70	1000	2000	500														
75	T65	1500	3000	750	60	90	265	58	3	35	50	54				X	X	
	T70	1850	3700	925														

Technical data											
Size	Elastomer hardness [Shore A]	C <sub>dyn.</sub> with 60 °C [Nm/rad]	Perm. damping power with 60 °C P <sub>KW</sub> [W]	Max. displacement with 2200 rpm ΔK <sub>r</sub> [mm]	Perm. angular displacement with 2200 rpm ΔK <sub>w</sub> [°]	Radial spring stiffness C <sub>r</sub> [N/mm]	Mass moment of inertia [kgm <sup>2</sup> ]			Perm. operating speed n <sub>max.</sub> [rpm]	
							JA	JL			
30	T65	3750	25	0.5	1	1150	6 1/2"	0.0038	0.00030	6000	
	T70	4875				1500	7 1/2"	0.0057			
50	T65	9000	35	0.5	1	1300	8"	0.0078	0.00120	6000	
	T70	12000				1700	10"	0.0153			
G50	T70	17500	40	0.5	1	1910	7 1/2"	0.0060	0.00120	6000	
							8"	0.0080			
							10"	0.0162			
65	T65	14000	45	0.5	1	1900	10"	0.0238	0.00380	6000	
	T70	18000				2450	11 1/2"	0.0368			
75	T65	34000	80	0.5	1	1850	10"	0.0272	0.01450	6000	
	T70	42000				2400	11 1/2"	0.0402			

T = Temperature-stable rubber compound. The technical data specified apply for an ambient temperature of T = 60 °C.

# BoWex-ELASTIC® HE1 - HE4

## Highly flexible flange couplings

Axial plug-in, available in different kinds of hardness



For legend of pictogram refer to flapper on the cover

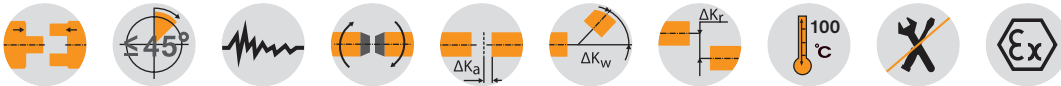

BoWex-ELASTIC® Type HE1 - HE4																										
Size	Bore d [mm]		Flange connection acc. to SAE - J620						Dimensions [mm]										Type HE1 / HE2		Type HE3 / HE4					
	Pilot bored	max.	6 1/2"	7 1/2"	8"	10"	11 1/2"	14"	l <sub>3</sub> HE1/HE2	l <sub>3</sub> HE3/HE4	D <sub>5</sub>	l <sub>2</sub> HE1/HE2	l <sub>2</sub> HE3/HE4	D <sub>4</sub>	D	l <sub>1</sub>	LHE1	LHE2	LHE3	LHE4	Weight with max. bore [kg]	Mass moment of inertia with max. bore [kgm <sup>2</sup> ]	Weight with max. bore [kg]	Mass moment of inertia with max. bore [kgm <sup>2</sup> ]		
																							JA	JL	JA	JL
42 HE	-	42	●	●					4	2	180	44.5	37	145	65	42	70	50	55	40	1.8	0.0074	0.0016	1.8	0.0071	0.0021
																						2.8	0.0172	0.0016	-	-
48 HE	-	48		●					4	2	198	45	37	163	68	50	78	50	68	42	2.3	0.0119	0.0021	1.9	0.0070	0.0022
																						2.6	0.0170	0.0021	2.1	0.0103
65 HE	21	65			●				5	-	244	55.5	-	205	96	55	85	62	-	-	4.9	0.0424	0.0069	-	-	-
																						5.7	0.0647	0.0069	-	-
G 65 HE	21	65				●			-	3	-	-	45	205	96	55	-	-	73	50	-	-	-	3.9	0.0147	0.0075
																						-	-	-	4.1	0.0281
GG 65 HE	21	65					●		-	3	-	-	45	220	96	55	-	-	73	50	-	-	-	4.6	0.0423	0.0075
																						-	-	-	3.8	0.0163
80 HE	31	90					●		-	4	316	70	56	265	124	90	126	74	112	60	8.1	0.0239	0.0307	9.1	0.0414	0.0305
																		132	80			10.2	0.0765	0.0307	-	-
G 80 HE	31	90						●	-	4	356	80	66	300	124	90	136	80	122	70	9.7	0.0426	0.0471	11.1	0.0713	0.0472
																		142	84			14.7	0.2851	0.0471	-	-
GG 80 HE	31	90						●	-	4	-	-	71	302	124	90	-	-	130	80	-	-	-	11.9	0.0768	0.0498
																						-	-	-	18.3	0.2028
100 HE	38	100						●	-	4	-	-	76	350	152	110	142	90	150	82	-	-	-	16	0.2172	0.1013
G 100 HE	38	100						●	-	4	-	-	76	350	152	65	-	-	102	85	-	-	-	16	0.2172	0.1013

Other flange connections on request

Technical data															
Size	Elastomer hardness [Shore A]	Torque [Nm]				Perm. damping power P <sub>KW</sub> [W]			Perm. operating speed n <sub>max.</sub> [rpm]	Dynamic torsion spring stiffness C <sub>dyn.</sub> [Nm/rad]	Relative damping ψ	Resonance factor V <sub>R</sub> ≈ 2 • π / ψ	Radial spring stiffness C <sub>r</sub> [N/mm]		
		T <sub>KN</sub>	T <sub>K</sub> max. 10,000 LA [Nm]	T <sub>K</sub> max. 50,000 LA [Nm]	with 10 Hz T <sub>KW</sub>	60 °C	80 °C	90 °C							
42 HE	T40	165	395	330	41	26.0	15.6	10.4	6200	550	0.6	10.5	142		
	T50	205	490	410	51									7.9	219
	T65	260	625	520	65										
48 HE	T40	250	600	500	63	36.0	21.6	14.4	5600	850	0.6	10.5	176		
	T50	315	755	630	79									7.9	269
	T65	400	960	800	100										
65 HE	T40	440	1050	880	110	60.0	36.0	24.0	4500	1600	0.6	10.5	209		
	T50	550	1320	1100	138									7.9	288
	T65	720	1730	1440	180										
G65 HE	T40	540	1300	1080	135	68.0	40.8	27.2	4300	2350	0.6	10.5	294		
	T50	700	1700	1400	175									7.9	375
	T65	890	2140	1780	223										
GG 65 HE	T40	750	1800	1500	188	76.0	45.6	30.4	4000	3650	0.6	10.5	420		
	T50	960	2300	1920	240									7.9	550
	T65	1250	3000	2500	313										
80 HE	T40	950	2280	1900	238	120.0	72.0	48.0	3600	4500	0.6	10.5	351		
	T50	1300	3120	2600	325									7.9	507
	T65	1750	4200	3500	438										
G 80 HE	T40	1600	3850	3200	400	180.0	108.0	72.0	3000	7500	0.6	10.5	476		
	T50	2200	5280	4400	500									7.9	762
	T65	2900	6960	5800	725										
GG 80 HE	T40	2000	4800	4000	500	196.0	117.6	78.4	3000	9200	0.6	10.5	660		
	T50	2750	6600	5500	688									7.9	1020
	T65	3600	8650	7200	900										
100 HE	T40	2500	6000	5000	625	210.0	126.0	84.0	2700	39600	1.2	5.2	2800		
	T50	3250	7800	6500	813									7.9	730
	T65	4250	10200	8500	1063										
G 100 HE	T40	3000	7200	6000	750	215.0	129.0	86.0	2700	48000	1.2	10.5	584		
	T50	3800	9120	7600	950									7.9	935
	T65	5000	12000	10000	1250										

The technical data specified apply for an ambient temperature of T = 60 °C.

Ordering example:	BoWex-ELASTIC® 42	HE1	T40	8	70	U
	Coupling size	Type	Elastomer hardness	Flange Ø D <sub>A</sub> according to SAE or special	Mounting length L <sub>HE</sub>	Unbored or with finish bore

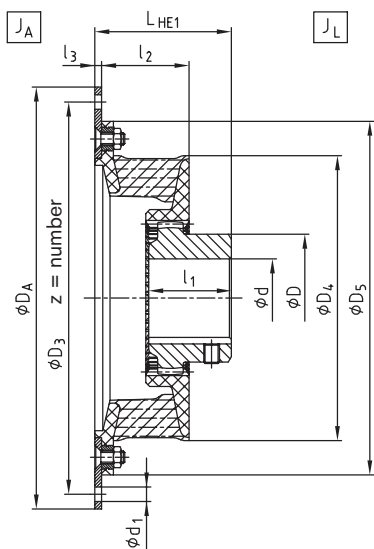

Type HE1

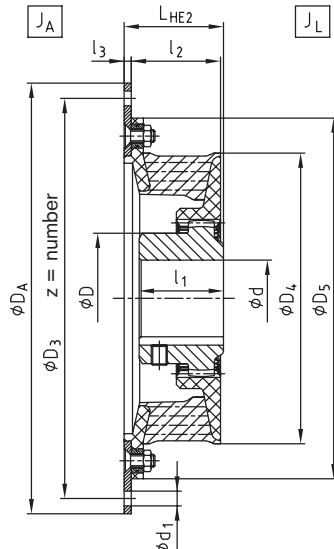

Type HE2

Flange dimensions according to SAE J620 [mm]				
Nominal size	DA	D3	z	d1
6 1/2"	215.90	200.02	6	9
7 1/2"	241.30	222.25	8	9
8"	263.52	244.47	6	11
10"	314.32	295.27	8	11
11 1/2"	352.42	333.37	8	11
14"	466.72	438.15	8	13

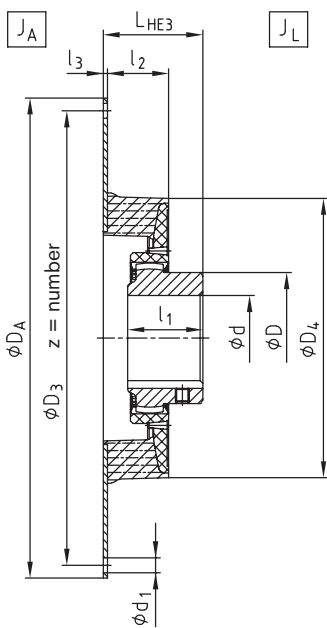

Type HE3

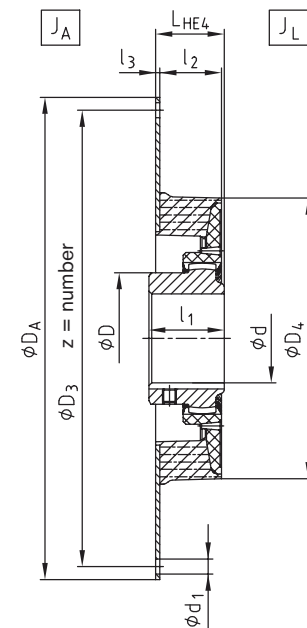

Type HE4

Displacements																
Size	42 HE			48 HE			65 HE G65 HE GG65 HE			80 HE G80 HE GG80 HE			100 HE G100 HE			
	T40	T50	T65	T40	T50	T65	T40	T50	T65	T40	T50	T65	T40	T50	T65	
Elastomer hardness [Shore A]	T40	T50	T65	T40	T50	T65	T40	T50	T65	T40	T50	T65	T40	T50	T65	
Perm. radial displacement ΔKr [mm]	n=1500 rpm	1.1	1.0	0.5	1.2	1.1	0.5	1.6	1.5	0.7	1.8	1.7	0.8	2.2	2.0	1.0
	max. 1)	3.6	3.3	1.5	3.8	3.5	1.7	5.1	4.7	2.2	5.7	5.3	2.4	6.5	6.0	3.0
Perm. angular displacement ΔKw [°]	n=1500 rpm	1.0	0.75	0.5	1.0	0.75	0.5	1.0	0.75	0.5	1.0	0.75	0.5	1.0	0.75	0.5
	n=3000 rpm	0.5	0.4	0.25	0.5	0.4	0.25	0.5	0.4	0.25	0.5	0.4	0.25	0.5	0.4	0.25
Perm. angular displacement ΔKw [°]	max. 1)			1.5			1.5			1.5			1.5			
Perm. axial displacement ΔKa [mm]	± 2			± 2			± 2			± 2			± 3			

1) For short-term start-up operation

Mounting procedure, screw type with property class, tightening torques as per KTR assembly instructions (see www.ktr.com).

# BoWex-ELASTIC® HE3 / HE4 / HE-D

## Highly flexible flange couplings

Axial plug-in, available in different kinds of hardness



For legend of pictogram refer to flapper on the cover

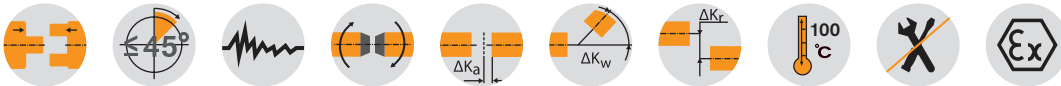

**BoWex-ELASTIC® Type HE3, HE4 and HE-D**

Size	Bore d [mm]		Flange connection acc. to SAE - J620							Dimensions [mm]							Weight with max. bore [kg]	Mass moment of inertia with max. bore [kgm <sup>2</sup> ]	
	Pilot bored	max.	14"	16"	18"	21"	24"	Ø800	Ø885	I3	I2	D <sub>4</sub>	D	I1	LHE3	LHE4		J <sub>A</sub>	J <sub>L</sub>
125 HE	45	125	•							6	92	416	192	140	186	103	33.1	0.3142	0.2750
G125 HE	45	125		•						6	89	440	192	140	179	91	34.8	0.4231	0.2750
150 HE	44	160			•					6	140	470	225	150	205	160	36.6	0.4634	0.3264
150 HE-D	44	160			•					-	286	470	225	275	291	-	39.5	0.6812	0.3264
G150 HE	44	160			•					6	140	504	225	150	205	160	46.8	0.7277	0.5414
G150 HE-D	44	160			•					-	286	504	225	275	291	-	51.5	1.2120	0.5414
200 HE	46	180				•				6	149	568	250	175	240	160	113	3.0045	1.0738
200 HE-D	46	180				•				-	325	568	250	298	310	-	155	6.4399	1.0738
G200 HE	46	180				•				6	149	600	250	175	240	160	51.9	0.8164	0.6500
G200 HE-D	46	180				•				-	325	600	250	298	310	-	56.6	1.3007	0.6500
240 HE	80	240					•			8	172	772	326	200	270	205	123	3.1820	1.291
275 HE	80	275						•		10	185	810	372	240	312	215	165	6.6173	1.291

**Technical data**

Size	Elastomer hardness [Shore A]	Torque [Nm]				Perm. damping power P <sub>KW</sub> [W]			Perm. operating speed n <sub>max.</sub> [rpm]	Dynamic torsion spring stiffness C <sub>dyn.</sub> [Nm/rad] 60 °C	Relative damping ψ	Resonance factor V <sub>R</sub> ≈ 2 • π / ψ	Radial spring stiffness C <sub>r</sub> [N/mm]
		T <sub>KN</sub> [Nm]	T <sub>K</sub> max. 10,000 LA [Nm]	T <sub>K</sub> max. 50,000 LA [Nm]	T <sub>KW</sub> [Nm]	60 °C	80 °C	90 °C					
125 HE	T40	3500	10500	7000	875	221	133	88	2300	20000	0.6	10.5	625
	T50	4800	11400	9600	1200								
	T70	6800	20400	13600	1700								
G125 HE	T40	4800	14400	7200	1200	240	144	96	2250	34000	0.6	10.5	890
	T50	6600	19800	9900	1650								
	T70	10000	30000	15000	2500								
150 HE	T50	8000	24000	12000	2000	262	157	105	2200	67500	0.8	7.9	714
	T70	14000	42000	21000	3500								
	T50	16000	48000	24000	4000								
150 HE-D	T50	16000	48000	24000	4000	524	314	210	2200	134000	0.8	7.9	1428
	T70	28000	84000	42000	7000								
	T50	10000	30000	15000	2500								
G150 HE	T50	18000	54000	27000	4500	278	167	111	2100	85000	0.8	7.9	1485
	T70	20000	60000	30000	5000								
	T50	20000	60000	30000	5000								
G150 HE-D	T50	36000	108000	54000	9000	556	334	222	2100	170000	0.8	7.9	2970
	T70	36000	108000	54000	9000								
	T50	14500	43500	21750	3625								
200 HE	T50	25000	75000	37500	6250	308	185	123	1900	241000	1.2	5.2	6769
	T70	29000	87000	43500	7250								
	T50	50000	150000	75000	12500								
200 HE-D	T50	29000	87000	43500	7250	616	370	246	1900	238000	0.8	7.9	3440
	T70	50000	150000	75000	12500								
	T50	17500	52500	26250	4375								
G200 HE	T50	30000	90000	45000	7500	324	194	130	1800	139000	0.8	7.9	1952
	T70	30000	90000	45000	7500								
	T50	35000	105000	52500	8750								
G200 HE-D	T50	60000	180000	90000	15000	648	388	260	1800	278000	0.8	7.9	3904
	T70	60000	180000	90000	15000								
	T50	29000	87000	43500	7250								
240 HE	T50	49000	147000	73500	12250	372	223	149	1500	521000	1.2	5.2	9160
	T70	42000	126000	63000	10500								
	T50	70000	210000	105000	17500								
275 HE	T50	42000	126000	63000	10500	410	246	164	1500	375000	0.8	7.9	2950
	T70	70000	210000	105000	17500								
	T50	70000	210000	105000	17500								

The technical data specified apply for an ambient temperature of T = 60 °C.

Ordering example:	BoWex-ELASTIC® 125	HE3	T40	14"	186	U
	Coupling size	Type	Elastomer hardness	Flange Ø D <sub>A</sub> according to SAE or special	Mounting length L <sub>HE</sub>	Unbored or with finish bore

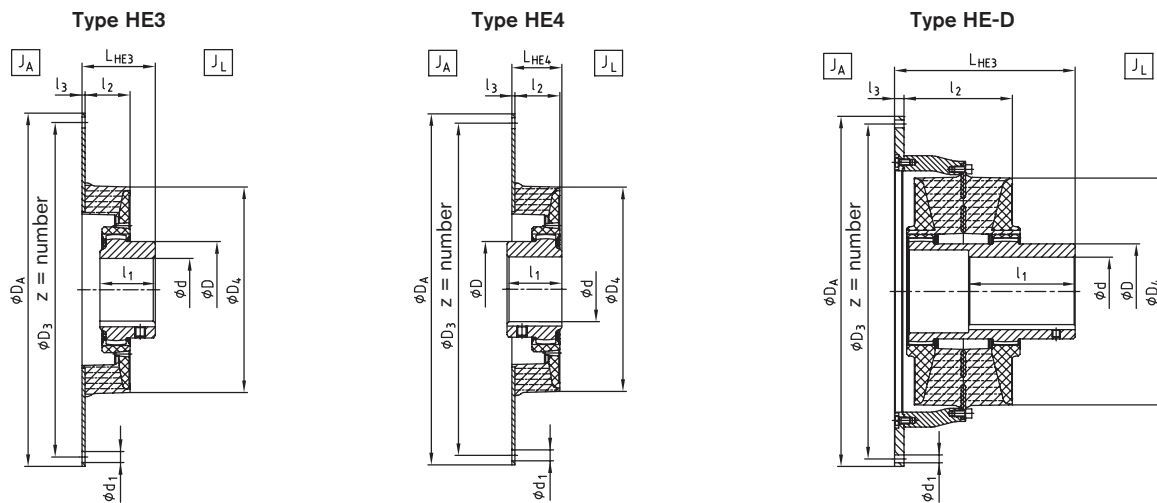

Type HE4 with taper clamping sleeve

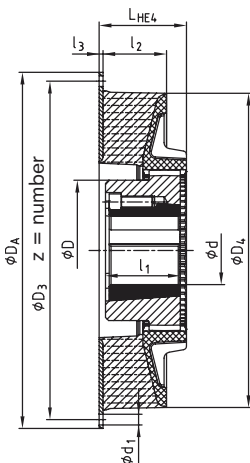

Flange dimensions according to SAE J620 [mm]				
Nominal size	DA	D3	z	d1
14"	466.72	438.15	8	13
16"	517.50	489.00	8	13
18"	571.50	542.90	6	17
21"	673.10	641.35	12	17
24"	733.42	692.15	12	21
Ø800 <sup>1)</sup>	800	770	32	17
Ø885 <sup>1)</sup>	885	855	36	17

<sup>1)</sup> Flange connection differing from SAE standard, dimensions in mm.

## Displacements

Radial displacement  $\Delta K_r$

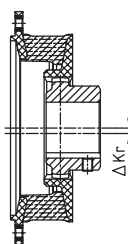

Angular displacement  $\Delta K_w$

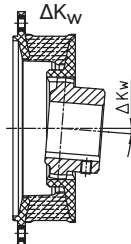

Axial displacement  $\Delta K_a$

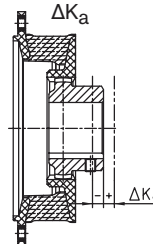

Displacements																
Size	125 HE G125 HE			150 HE G150 HE			200 HE G200 HE			240 HE			275 HE			
	T40	T50	T70	T40	T50	T70	T40	T50	T70	T40 Sh	T50	T70	T40	T50	T70	
Perm. radial displacement $\Delta K_r$ [mm]	n=1500 rpm	2.5	2.3	1.1	2.8	2.5	1.3	3.0	2.7	1.5	3.2	2.9	1.6	3.4	3.1	1.8
	max. <sup>2)</sup>	7.5	6.9	3.3	8.0	7.5	4.0	8.5	8.0	4.5	9.0	8.5	5.0	9.5	9.0	5.5
Perm. angular displacement $\Delta K_w$ [°]	n=1500 rpm	1.0	0.75	0.5	1.0	0.75	0.5	1.0	0.75	0.5	1.0	0.75	0.5	1.0	0.75	0.5
	n=3000 rpm	0.5	0.4	0.25	-	-	-	-	-	-	-	-	-	-	-	-
Perm. angular displacement $\Delta K_w$ [°]	max. <sup>2)</sup>	1.5			1.5			1.5			1.5			1.5		
Perm. axial displacement $\Delta K_a$ [mm]	± 3			± 4			± 4			± 4			± 4			

<sup>2)</sup> For short-term start-up operation

Mounting procedure, screw type with property class, tightening torques as per KTR assembly instructions (see [www.ktr.com](http://www.ktr.com)).

# BoWex-ELASTIC® HE-ZS and HEW Highly flexible flange couplings

With drop-out center design piece for pump drives, highly flexible shaft-to-shaft coupling



For legend of pictogram refer to flapper on the cover

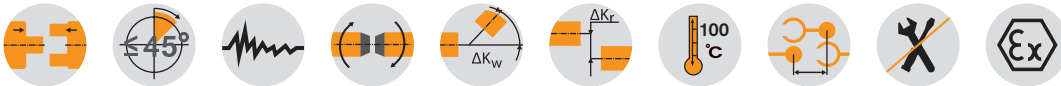

### BoWex-ELASTIC® Type HE-ZS

Size	Max. finish bore d4	Flange connection acc. to SAE - J620 DA for HE-ZS										Dimensions [mm]								Drop-out center design piece HE-ZS LZ [mm]					Weight with max. bore [kg]	Mass moment of inertia [kgm <sup>2</sup> ]									
		6 1/2"	7 1/2"	8"	10"	11 1/2"	14"	16"	18"	21"	24"	D1	D4	D5	D7	D8	I1	I2	I3	I6	100	120	140	180		250	JA	JL							
48 <sup>3)</sup>	28	•																											2.9 <sup>1)</sup>	0.0026	0.0033				
			•									160	164	200	78	45	40												3.6 <sup>1)</sup>	0.0106	0.0033				
G65 <sup>3)</sup>	45		•																																
				•								205		110	72	60	48	3	56										7.3 <sup>1)</sup>	0.0242	0.0129				
80 <sup>3)</sup>	65			•																															
					•							265	266	318	145	100	80	70	11	76									13.7 <sup>2)</sup>	0.0211	0.0497				
G80 <sup>3)</sup>	65				•																														
						•						300	302	358	145	100	80	80	11	76									14.6 <sup>2)</sup>	0.0402	0.0634				
100 <sup>3)</sup>	95					•																													
							•					350		202	148	110	80	4	106											19.5 <sup>2)</sup>	0.2251	0.0634			
125 <sup>4)</sup>	100						•																												
								•				416		225	165	120	99	6	116											29.8 <sup>2)</sup>	0.1951	0.1779			
G125 <sup>4)</sup>	120							•																											
									•			440		225	165	120	95	6	116												41.7 <sup>2)</sup>	0.3013	0.3363		
150 <sup>4)</sup>	135																																		
										•		470		245	185	140	140	6	136												43.6 <sup>2)</sup>	0.4123	0.3363		
G150 <sup>4)</sup>	135																																		
											•	504		245	185	140	140	6	136												45.6 <sup>2)</sup>	0.4781	0.3700		
200 <sup>4)</sup>	150																																		
												•	568		270	205	160	149	6	156												47.7 <sup>2)</sup>	0.6380	0.3700	
G200 <sup>4)</sup>	150																																		
													•	600		270	205	160	149	6	156											63.2	0.6918	0.6647	
																																	67.9	1.1410	0.6647
																																		68.3	0.7540
																																		73.0	1.2460
																																			98.7
																																			101.7
																																			103.5
																																			106.6

<sup>1)</sup> with L<sub>2</sub> 120  
<sup>2)</sup> with L<sub>2</sub> 100

<sup>3)</sup> For technical data see page 220

<sup>4)</sup> For technical data see page 222

### BoWex-ELASTIC® Type HEW

Size	Max. finish bore		Dimensions [mm]														Weight with max. bore [kg]	Mass moment of inertia [kgm <sup>2</sup> ]			
	d <sub>2</sub>	d <sub>3</sub>	D	D <sub>2</sub>	z x M	D <sub>4</sub>	D <sub>5</sub>	D <sub>6</sub>	I <sub>1</sub>	I <sub>2</sub>	I <sub>3</sub>	I <sub>4</sub>	I <sub>5</sub>	E	E <sub>1</sub>	L <sub>HEW1</sub>		L <sub>HEW2</sub>	JA	JL	
42	48	50	68	162	6	M6	146	180	85	50	45	15	50	42	4	32	132	104	4.3	0.0121	0.0015
48 <sup>3)</sup>	48	55	68	180	8	M6	164	200	92	50	45	17	55	45	4	32	137	109	5.5	0.0204	0.0019
65 <sup>3)</sup>	65	75	96	224	8	M8	205	245	125	70	55	28	75	63	5	42	187	150	13.2	0.0752	0.0071
80 <sup>3)</sup>	90	80	124	295.27	8	M10	266	318	130	90	70	17	80	70	5	45	215	160	19.7	0.1449	0.0285
G80 <sup>3)</sup>	90	95	124	333.4	8	M10	302	358	145	90	80	22	90	78	5	55	235	185	25.9	0.2748	0.0422
100 <sup>3)</sup>	100	110	152	438.15	8	M12	350	478	158	110	80	14	111.5	113	26	57	278	207	48.5	0.8356	0.1050
125 <sup>4)</sup>	125	125	192	438.15	8	M12	416	478	175	140	99	14	170	158	-	45	355	-	67.2	0.9498	0.2617
G125 <sup>4)</sup>	125	125	192	489	8	M12	440	530	175	140	95	14	170	158	-	45	355	-	76.6	1.4492	0.3034
150 <sup>4)</sup>	160	160	225	542.9	6	M16	470	585	225	150	100	18	160	145	-	70	380	-	110	2.7206	0.5303
G150 <sup>4)</sup>	160	160	225	542.9	6	M16	504	585	225	150	108	18	160	145	-	70	380	-	113.4	2.7809	0.5861
200 <sup>4)</sup>	180	200	250	641.35	12	M16	568	683	280	175	149	26	220	214	-	85	480	-	195	6.6418	1.1406
G200 <sup>4)</sup>	180	200	250	641.35	12	M16	600	683	280	175	149	26	220	214	-	85	480	-	200	6.6099	1.3419

<sup>3)</sup> For technical data see page 220

<sup>4)</sup> For technical data see page 222

Other sizes available. Please consult with us.

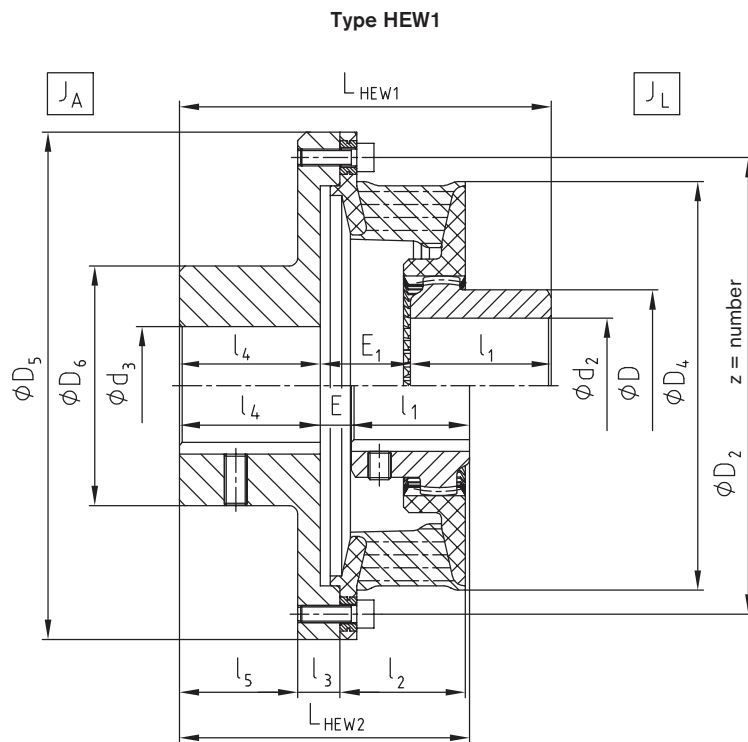
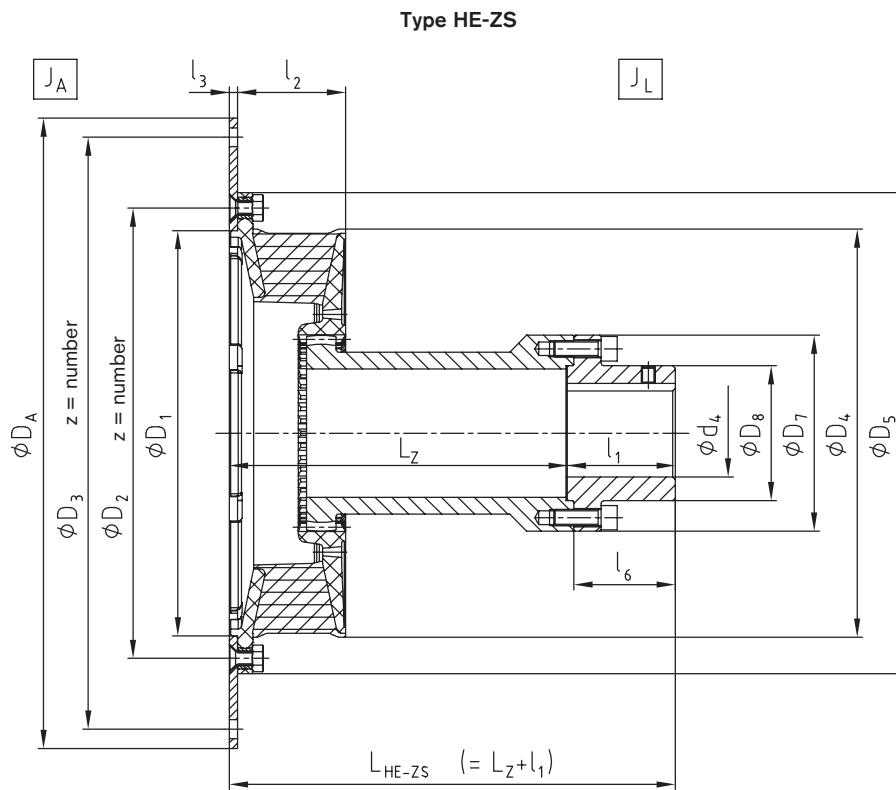

**Type HEW2**

# BoWex-ELASTIC® HEG

## Highly flexible flange couplings

### Cardan shaft connecting coupling



For legend of pictogram refer to flapper on the cover

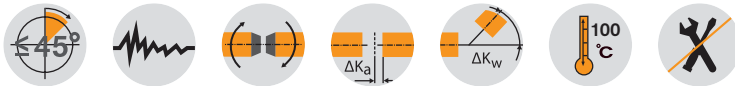

BoWex-ELASTIC® Type HEG1 and type HEG2																														
Size	Flywheel connection acc. to SAE-J620					Metric flange connection HEG1 dimensions [mm]										MECHANICS cardan shaft connection HEG2 dimensions [mm]								Dimensions [mm]			Weight [kg]	Mass moment of inertia		
	8"	10"	11 1/2"	14"	16"	58	65	75	90	100	120	150	180	l4	L	2 C	4 C	5 C	6 C	7 C	8,5 C	8 C	L1	D4	l2	l3		J <sub>A</sub> [kgm <sup>2</sup> ]	J <sub>L</sub> [kgm <sup>2</sup> ]	
48 <sup>1)</sup>	●					●	●	●						8	58.5										163	43.5	8	7	0.03	0.006
		●				●	●	●									●	●	●								8	0.06	0.006	
G65 <sup>1)</sup>		●						●	●	●				8	66		●	●	●					71	205	48.0	10	12	0.07	0.02
			●					●	●	●	●						●	●	●								14	0.10	0.02	
80 <sup>1)</sup>		●						●	●	●	●			10	88.5			●	●	●				104	265	68.5	23	21	0.11	0.06
			●					●	●	●	●	●					●	●	●								12	23	0.17	0.06
G80 <sup>1)</sup>			●					●	●	●	●	●		10	96			●	●	●	●			110	302	74.0	23	26	0.18	0.09
				●				●	●	●	●	●	●				●	●	●								12	33	0.48	0.09
100 <sup>1)</sup>				●				●	●	●	●	●	●	12	98					●	●			128	350	78.0	16	41	0.63	0.19
125 <sup>2)</sup>				●				●	●	●	●	●	●	12	111						●	●		135	416	96.0	18	56	0.74	0.42
					●			●	●	●	●	●	●								●	●				12	59	0.97	0.42	

<sup>1)</sup> For technical data see page 220

<sup>2)</sup> For technical data see page 222

Flywheel connection acc. to SAE-J620				
Size	D <sub>A</sub>	D <sub>1</sub>	z <sub>1</sub>	d <sub>1</sub>
8"	263.52	244.47	6	11
10"	314.32	295.27	8	11
11 1/2"	352.42	333.37	8	11
14"	466.72	438.15	8	14
16"	517.50	489.00	8	14

Metric flange connection HEG1 [mm]					
Size	D <sub>2</sub>	l1	D <sub>3</sub>	z <sub>2</sub>	d <sub>2</sub>
58	30	1.0	47.0	4	M5
65	35	1.0	52.0	4	M6
75	42	1.5	62.0	6	M6
90	47	2.0	74.5	4	M8
100	57	2.0	84.0	6	M8
120	75	2.0	101.5	8	M10
150	90	2.5	130.0	8	M12
180	110	3.0	155.5	8	M14

MECHANICS cardan shaft connection HEG2 [mm]						
Size	D <sub>5</sub>	l5	l6	l7	l8	z <sub>3</sub>
2 C	79.35	33.3	59.5	9.50	3.8	M8
4 C	107.92	36.5	87.3	9.50	3.8	M8
5 C	115.06	42.9	88.9	14.26	5.1	M10
6 C	140.46	42.9	114.3	14.26	5.1	M10
7 C	148.39	49.2	117.5	15.85	6.0	M12
8,5 C	165.08	71.4	123.8	15.85	6.0	M12
8 C	206.32	49.2	174.6	15.85	6.0	M12

BoWex-ELASTIC® type HEG has a maintenance-free plain bearing compensating for the radial loads generated by the cardan shaft. Moreover, the coupling has a friction disk which is axially prestressed by the elastomer part. The elastomer part is made of natural rubber via vulcanizing.

The permanent friction provides the coupling with excellent damping properties considerably reducing the high vibratory torques generated in the coupling during the starting process and passing through resonance.

Type HEG1

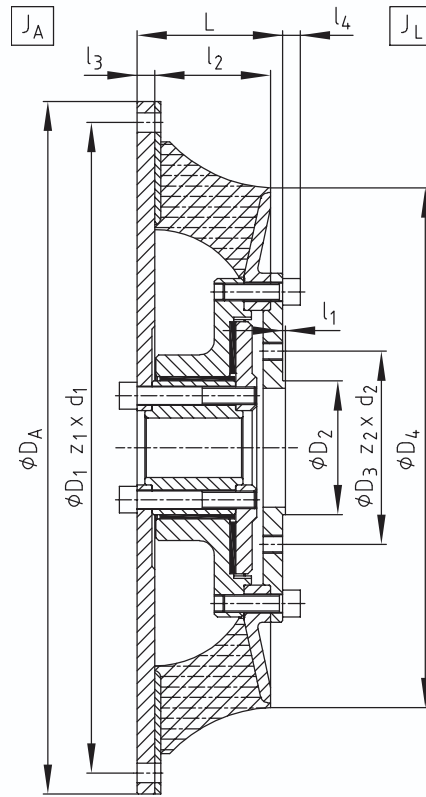

Type HEG2

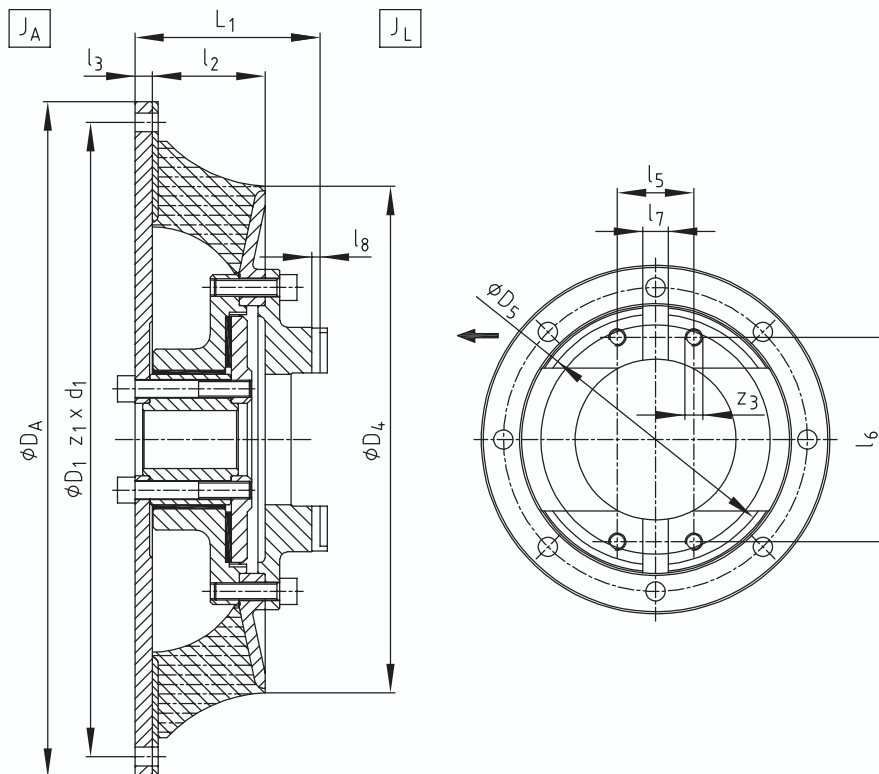

# SINULASTIC®

## highly flexible flange couplings

### Description of product and application

The SINULASTIC® is a highly flexible flange coupling based on a disk-shaped coupling body. Four basic versions cover a wide range of applications primarily for diesel engine drives.

The main task of the coupling is reducing torsional vibrations resulting from excitations of the I. C.-engine during standard operation and misfire operation as well as protecting the drive from overload. It can be used both for variable-speed and constant speed drives, while a supercritical selection of the drive train above resonance level is always made. It requires only very few (axial) installation space due to its compact shape.

Depending on the type the coupling is pluggable and compensates for displacements. It is a non-slip or shear type and radially mountable.

The elastomer element is available in various qualities for all types. It is composed of natural rubber compounds optimised over many years (SN, MN, HN, UN up to 100 °C) or upon request of synthetical EPDM material for higher temperatures (SE, ME, HE, UE up to 120 °C) as well as silicone rubber (SC, MC up to 120 °C). The various kinds of rubber hardness cover one application and torque range per size. The vibratory properties of the four types are compatible within one size.

A wide standard portfolio of hub connections covers a large variety of shaft configurations on the driven side while special connections can be implemented.



### SINULASTIC® - The types



A



T

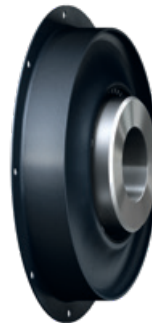

B



V

SINULASTIC® A was developed from the design of the renowned disk coupling with plug-in spline between elastomer and flange ring as well as a hub vulcanized on. The tooth shape that is subject to high loads particularly with alternating loads in the contact area between engine flange and rubber was extensively optimized, the sinusoidal tooth shape resulting from that is eponymous for the series. The engine flange was executed by a deep-drawn sheet metal section creating a smooth surface to the elastomer. Another benefit is the tight contact gap for easy mountability with simultaneously highly sound and defined form fit.

In contrast to type A, a Taperlock shaft connection as a standard version with feather key is used with SINULASTIC® T. The modular concept makes use of the plug-in ability of type A on the flange side.

Type B and V make use of a deep-drawn and inherently stable flange ring that the elastomer part is externally vulcanized on. This results in a low-cost solution for high speeds and overloads.

In combination with the renowned BoWex® inner hub the SINULASTIC® B as an all-rounder of the overall series is formed. The so-called BoWex® hub defines a pluggable connection resistant to high loads as well as favourable adaptations on the driven side up to long driving shaft systems owing to the potentials for particularly high displacements. The hub and connection variants of BoWex®-ELASTIC are fully compatible with the elastomers of this series.

SINULASTIC® V is favourably used where the ability for axial plug-in is not required. A resulting radial assembly is realised by a split ring on the hub side.

The slim shape of the elastomers allows for wear-free displacements in axial, radial and angular direction, while the coupling element is optimally suitable for not flange-mounted assembly, i. e. for system configurations set up freely.

# SINULASTIC®

## highly flexible flange couplings

BoWex® FLE-PA/-PAC

MONOLASTIC®

BoWex-ELASTIC®

Flange couplings

SINULASTIC®

VAROLASTIC®

### Properties of types by comparison

Features	Types		
	SINULASTIC® A SINULASTIC® T	SINULASTIC® V	SINULASTIC® B
Rated torque $T_{KN}$	Compatible within the series		
Maximum torque $T_{Kmax}$	$\geq 2x T_{KN}$	$3x T_{KN}$	$3x T_{KN}$
Vibratory properties, e. g. torsional stiffness	Compatible within the series		
Materials <sup>1)</sup>	Natural rubber (NR) in the hardness ranges WN, SN, MN, HN synthetical rubber (EPDM) in the hardness ranges WE, SE, ME, HE silicone rubber (Si) in the hardness ranges SC, MC		
Plug-in	Yes	No	Yes
Radial assembly	Partially possible	Yes	No
Mounting length	++	Ø	++
Axial displacement	++	+	++
Radial displacement	Ø	+	+
Angular displacement	Ø	++	++
Standard	For flywheel flange and shaft connection (SAE J620, DIN 5480 et seqq., DIN 6281, etc.)		
special solutions	Bearing-mounted connecting coupling, with failure protection, combination with shifting unit	Cardanic offset joint, failure protection, shaft systems	
	Application-specific shaft connections of elastomer elements		

<sup>1)</sup>The standard materials and availabilities depend on the size and type, special compounds available on request

### Displacements of type A/T

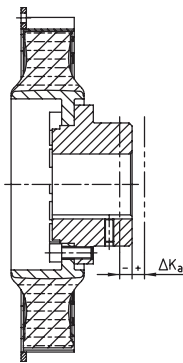

Axial displacement

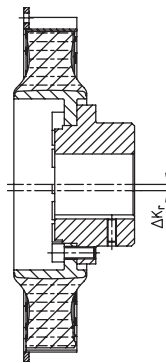

Radial displacement

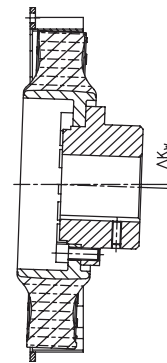

Angular displacement

SINULASTIC® size		20	28	38	53	96	114	140	180
Perm. axial displacement $\Delta K_a$ [mm] <sup>2)</sup>		$\pm 2.0$	$\pm 3.0$	$\pm 3.0$	$\pm 3.0$	$\pm 3.0$	$\pm 3.0$	$\pm 3.0$	$\pm 3.0$
Perm. radial displacement $\Delta K_r$ [mm]	1500 rpm	0.8	1.1	1.1	1.1	1.25	1.25	1.5	1.5
	$n_{max.}$	0.6	0.8	0.8	0.8	0.9	0.9	1.1	1.1
	max. <sup>1)</sup>	1.6	2.2	2.2	2.2	2.5	2.5	3.0	3.0
Perm. angular displacement $\Delta K_w$ [degree]	1500 rpm	0.7	0.6	0.6	0.6	0.5	0.5	0.4	0.4
	$n_{max.}$	0.5	0.4	0.4	0.4	0.4	0.4	0.3	0.3
	max. <sup>1)</sup>	1.1	0.9	0.9	0.9	0.8	0.8	0.6	0.6

<sup>1)</sup>With assembly, for a short time resp. rarely with downtime or start-up operation as well as exceptional load conditions.

<sup>2)</sup>Plug-in fit in the tooth contact allows for alternative mounting lengths

### Types of hubs type AK / AL <sup>1)</sup>

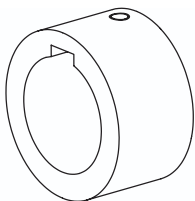

**Type 1.0**  
with feather keyway  
and setscrew  
(acc. to standard AK, AL)

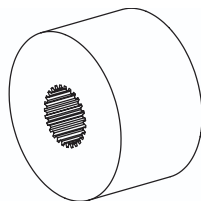

**Type 1.3**  
spline toothing

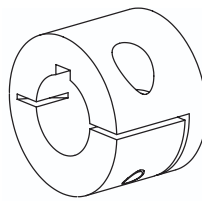

**Type 2.6**  
clamping hub double slot,  
with feather keyway

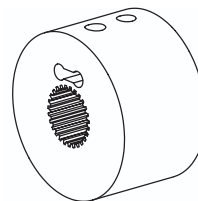

**Type 3.1**  
spline/clamping hub N

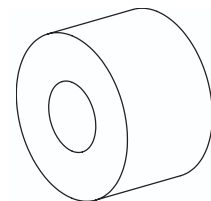

**Type 8.0**  
taper interference fit

**Type 8.1**  
cylindrical  
interference fit

<sup>1)</sup>Dimensions and type may differ depending on size, other types of hubs on request

# SINULASTIC®

## highly flexible flange couplings

### Technical data

Natural rubber (NR)														
Size	Elastomer type	Torque [Nm]				Dynamic torsion spring stiffness $C_{dyn}$ [Nm/rad] <sup>2)</sup>		Relative damping $\psi$ [-]		Perm. damping power [W] <sup>3)</sup>			Operating speed [rpm]	
		$T_{KN}$ <sup>1)</sup>	$T_{Kmax}$ 50,000 LA [Nm]	$T_{Kmax}$ 1,000 LA [Nm]	$T_{KW}$	30 °C	60 °C	30 °C	60 °C to 80 °C	30 °C	60 °C	80 °C	n	$n_{max}$
20	SN	1800	2700	3600	720	7500	6150	1.00	0.70	210	130	80	2700	3000
	MN	2000	3000	4000	800	11500	9430	1.10	0.77	240	149	91	2700	3000
	HN	2500	3750	7500	1000	18500	15170	1.30	0.91	270	167	103	3240	3600
	UN	2850	4275	8550	1140	22000	18040	1.40	0.98	290	180	110	3240	3600
	WN	2000	3000	4000	800	9800	8036	0.90	0.63	240	149	91	2340	2600
28	SN	2200	3300	4400	880	12500	10250	1.00	0.70	260	161	99	2340	2600
	MN	2800	4200	5600	1120	17000	13940	1.10	0.77	270	167	103	2340	2600
	HN	3400	5100	10200	1360	24000	19680	1.30	0.91	290	180	110	2520	2800
	UN	3750	5625	11250	1500	30000	24600	1.40	0.98	310	192	118	2520	2800
	SN	3100	4650	6200	1240	15000	12300	1.00	0.70	275	171	105	2520	2800
38	MN	3800	5700	7600	1520	22000	18040	1.10	0.77	300	186	114	2520	2800
	HN	4600	6900	13800	1840	35000	28700	1.30	0.91	330	205	125	2880	3200
	UN	5100	7650	15300	2040	41000	33620	1.40	0.98	350	217	133	2880	3200
	SN	4200	6300	8400	1680	17000	13940	1.00	0.70	285	177	108	2340	2600
	MN	5300	7950	10600	2120	28000	22960	1.10	0.77	325	202	124	2340	2600
53	HN	6200	9300	18600	2480	45500	37310	1.30	0.91	370	229	141	2700	3000
	UN	7000	10500	21000	2800	52000	42640	1.40	0.98	400	248	152	2700	3000
	SN	8100	12150	16200	3240	75000	61500	1.00	0.70	480	298	182	2070	2300
	MN	10000	15000	20000	4000	100000	82000	1.10	0.77	500	310	190	2070	2300
	HN	11200	16800	33600	4480	135000	110700	1.30	0.91	510	316	194	2250	2500
96	UN	13200	19800	39600	5280	175000	143500	1.40	0.98	520	322	198	2250	2500
	SN	10000	15000	20000	4000	90000	73800	1.00	0.70	500	310	190	2070	2300
	MN	11400	17100	22800	4560	125000	102500	1.10	0.77	530	329	201	2070	2300
	HN	13400	20100	40200	5360	160000	131200	1.30	0.91	550	341	209	2250	2500
	UN	15600	23400	46800	6240	190000	155800	1.40	0.98	560	347	213	2250	2500
140	SN	13000	19500	26000	5200	106000	86920	1.00	0.70	540	335	205	1890	2100
	MN	14000	21000	28000	5600	149000	122180	1.10	0.77	550	341	209	1890	2100
	HN	16200	24300	48600	6480	235000	192700	1.30	0.91	570	353	217	2070	2300
	UN	19000	28500	57000	7600	330000	270600	1.40	0.98	590	366	224	2070	2300
	SN	16000	24000	32000	6400	132000	108240	1.00	0.70	620	384	236	1890	2100
180	MN	18000	27000	36000	7200	185000	151700	1.10	0.77	630	391	239	1890	2100
	HN	22000	33000	66000	8800	295000	241900	1.30	0.91	650	403	247	2070	2300
	UN	25000	37500	75000	10000	380000	311600	1.40	0.98	670	415	255	2070	2300

Synthetical rubber (EPDM)					
Size	Elastomer type	Torque [Nm]			
		$T_{KN}$ <sup>1)</sup>	$T_{Kmax}$ 50,000 LW	$T_{Kmax}$ 1,000 LW	$T_{KW}$
20	SE	1800	2700	3600	720
	ME	2000	3000	4000	800
	HE	2500	3750	7500	1000
	UE	2850	4275	8550	1140
	SE	2200	3300	4400	880
28	ME	2800	4200	5600	1120
	HE	3400	5100	10200	1360
	UE	3750	5625	11250	1500
	SE	3100	4650	6200	1240
	ME	3800	5700	7600	1520
38	HE	4600	6900	13800	1840
	UE	5100	7650	15300	2040
	SE	4200	6300	8400	1680
	ME	5300	7950	10600	2120
	HE	6200	9300	18600	2480
53	UE	7000	10500	21000	2800
	SE	8100	12150	16200	3240
	ME	10000	15000	20000	4000
	HE	11200	16800	33600	4480
	UE	13200	19800	39600	5280
96	SE	10000	15000	20000	4000
	ME	11400	17100	22800	4560
	HE	13400	20100	40200	5360
	UE	15600	23400	46800	6240
	SE	13000	19500	26000	5200
140	ME	14000	21000	28000	5600
	HE	16200	24300	48600	6480
	UE	19000	28500	57000	7600
	SE	16000	24000	32000	6400
	ME	18000	27000	36000	7200
180	HE	22000	33000	66000	8800
	UE	25000	37500	75000	10000

Silicone rubber (SI)						
Size	Elastomer type	$T_{KN}$ RT <sup>4)</sup>	Torque [Nm] with +80 °C Ambient temperature <sup>1)</sup>			
			$T_{KN}$ <sup>1)</sup>	$T_{Kmax}$ 50,000 LW	$T_{Kmax}$ 1,000 LW	$T_{KW}$
20	SC	1800	1390	2080	2770	555
	MC	2000	1540	2310	3080	620
	SC	2200	1695	2540	3390	680
28	MC	2800	2155	3235	4310	865
	SC	3100	2390	3580	4770	955
38	MC	3800	2925	4390	5850	1170
	SC	4200	3235	4850	6465	1295
53	MC	5300	4080	6120	8155	1635
	SC	8100	6235	9350	12465	2495
96	MC	9600	7390	11080	14770	2955
	SC	9200	7080	10620	14155	2835
114	MC	11400	8770	13155	17540	3510
	SC	12500	9620	14435	19235	3850
140	MC	14000	10770	16155	21540	4310
	SC	16000	12310	18465	24620	4925
180	MC	18000	13850	20770	27695	4800

<sup>1)</sup>  $T_{KN}$  Torque that can be constantly transmitted over the entire speed range.  
<sup>2)</sup> Observe with selection DIN 740 part II (operating factor, temperature factor), parameters for an ambient temperature of 20 °C  
<sup>3)</sup> referring to 0.5  $T_{KW}$   
<sup>4)</sup> Here permanent damping power. Twice the damping power figure is permissible for one hour.  
<sup>5)</sup> Reference value with an ambient temperature of +20 °C

# SINULASTIC® highly flexible flange couplings

## Pluggable disk coupling with optimal tooth contact



For legend of pictogram refer to flapper on the cover

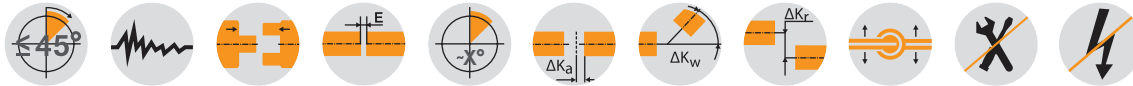

Type AK

Type AL

Types AK and AL specify the standard with variable hub connections as a short or long version

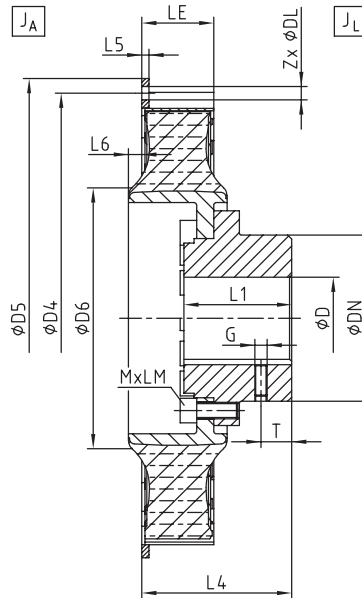
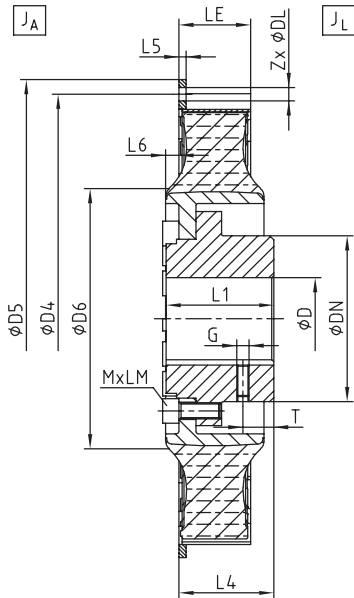

Flange dimensions according to SAE J620 [mm]				
Nominal size	D5	D4	Z	DL
11 1/2"	352.42	333.37	8	11
14"	466.72	438.15	8	13
18"	571.50	542.90	6	17
21"	673.10	641.35	12	17
24"	733.42	692.15	12	21
Ø475	475	450	12	11

SINULASTIC® type AK / AL																																		
Size	Flange connection acc. to SAE - J620						Dimensions [mm]										Mass moment of inertia [kgm²] 1)		Weight [kg] 1)															
	11 1/2"	14"	18"	21"	24"	Ø475	Max. finish bore D	DN	D6	LE	L1	L4		L6	L7	MxLM	G	T		JA	JL													
	AK	AL	L6	L7	MxLM	G	T	AK	AL																									
20	•						80	112	164	65	75	90.5 +3.5/-4.5	127.5 +3.5/-4.5	5.5	41.0 13.6	M12x30	M10	30	0.0947	0.0533	13.70													
28		•					115	162	244	44	90	93.5 ±3	109 ±3	7.0	7.0	M16x40	M12	35	0.1353	0.0533	14.79													
			•																											0.1873	0.1667	21.89		
				•																													0.4968	0.1667
38			•				115	162	244	58	100	93.5 ±3	123 ±3	7.0	7.0	M16x40	M12	35	0.2013	0.1667	22.15													
				•																												0.2444	0.1994	25.53
					•																												0.5539	0.1994
53				•			115	162	247	70	105	92.5 ±3	146 ±3	13.0	7.0	M16x40	M12	40	0.2584	0.1994	25.79													
					•																											0.7310	1.0321	63.86
						•																											0.2906	0.2378
96					•		175	248	352	84	150	129 ±4	192 ±4	1.0	11.0	M20x50	-	-	0.6000	0.2378	34.09													
						•																										0.3046	0.2378	29.70
																			•														0.7310	1.0321
114						•	175	248	352	98	150	129 ±4	206 ±4	1.0	11.0	M20x50	-	-	1.5407	1.0321	72.34													
																			•													2.2186	1.0321	77.90
																				•													0.8367	1.1212
140							175	248	431	94	200	200 ±3.5	280 ±3.5	3.0	14.0	M20x60	-	-	1.6464	1.1212	76.48													
																			•													2.3243	1.1212	82.05
																				•													1.6664	2.1577
180							175	248	431	114	200	200 ±3.5	300 ±3.5	3.0	14.0	M20x60	-	-	2.5280	2.1577	108.59													
																			•													1.9539	2.4188	109.82
																				•													2.8167	2.4188

1) With max. bore

Ordering example:	SINULASTIC® 96	AK	MN	18	1.0	Ø150
	Coupling size	Type	Elastomer type	Flange ØDA acc. to SAE or special	Hub type	Finish bore

# SINULASTIC® highly flexible flange couplings

## Pluggable disk coupling with optimal tooth contact



For legend of pictogram refer to flapper on the cover

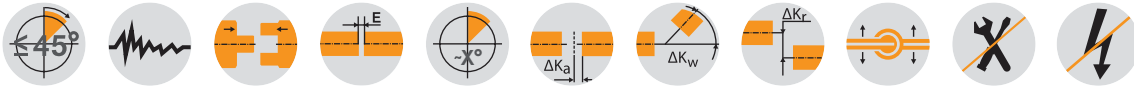

Type AKC

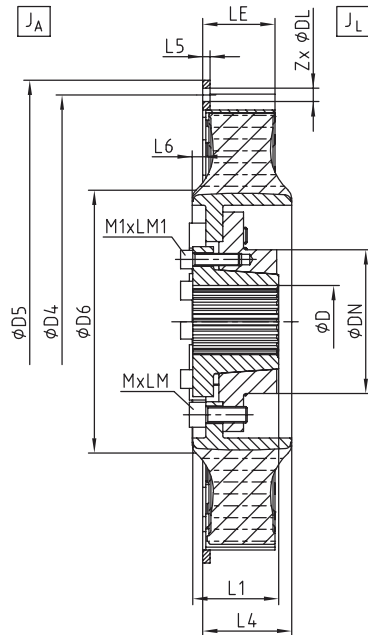

Type ALC

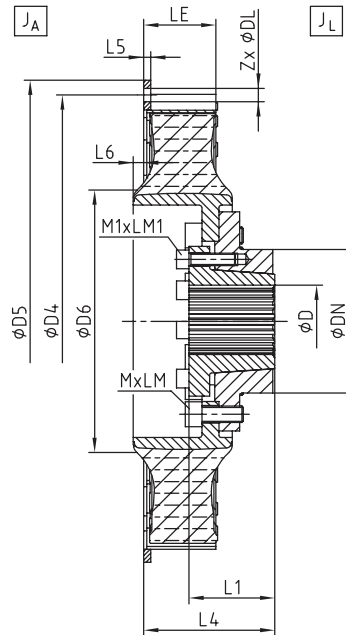

Types AKC and ALC  
identify the hub type  
as a spline clamping ring hub

Flange dimensions according to SAE J620 [mm]				
Nominal size	D5	D4	Z	DL
11 1/2"	352.42	333.37	8	11
14"	466.72	438.15	8	13
18"	571.50	542.90	6	17
21"	673.10	641.35	12	17
24"	733.42	692.15	12	21
Ø475	475	450	12	11

SINULASTIC® type AKC / ALC																					
Size	Flange connection acc. to SAE - J620						Dimensions [mm]										Mass moment of inertia [kgm <sup>2</sup> ] <sup>1)</sup>		Weight [kg] <sup>1)</sup>		
	11 1/2"	14"	18"	21"	24"	Ø475	Finish bore D		DN	D6	LE	L1	L4		L6	L7	MxLM	M1xLM1		JA	JL
							Pilot bored	max.					AK	AL							
20	●						30	50	109	164	65	57	70.5 +3.5/-4.5	95.5 +3.5/-4.5	5.5	41.0	M12x30	M10x30	0.0947	0.0520	13.93
		●														13.6			0.1353	0.0520	15.02
28		●					46	65	139	244	44	63	56.5 ±3	72 ±3	7.0	7.0	M16x40	M10x40	0.1873	0.1525	21.15
			●			●													0.4968	0.1525	25.79
38			●				46	80	139	244	58	69	65 ±3	92 ±3	7.0	7.0	M16x40	M10x40	0.2013	0.1525	21.40
				●		●													0.2444	0.1837	24.05
53				●			46	80	139	244	58	69	65 ±3	92 ±3	7.0	7.0	M16x40	M10x40	0.5539	0.1837	28.70
					●	●													0.2584	0.1837	24.31
53					●		46	80	139	247	70	83	83 ±3	124 ±3	13.0	7.0	M16x40	M12x45	0.2906	0.2240	28.72
						●													0.6000	0.2240	33.37
						●													0.3046	0.2240	28.98

<sup>1)</sup> With max. bore

Ordering example:	SINULASTIC® 53	AKC	MN	18	6.0	DIN 5480 - 60x2x28
	Coupling size	Type	Elastomer type	Flange ØDA acc. to SAE or special	Hub type	Finish bore

# SINULASTIC® highly flexible flange couplings

## Pluggable disk coupling with optimal tooth contact



For legend of pictogram refer to flapper on the cover

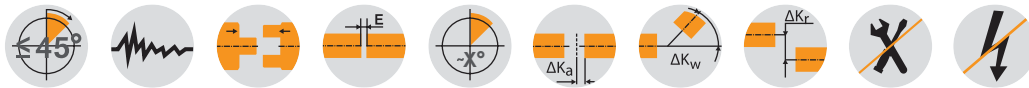

### Type T

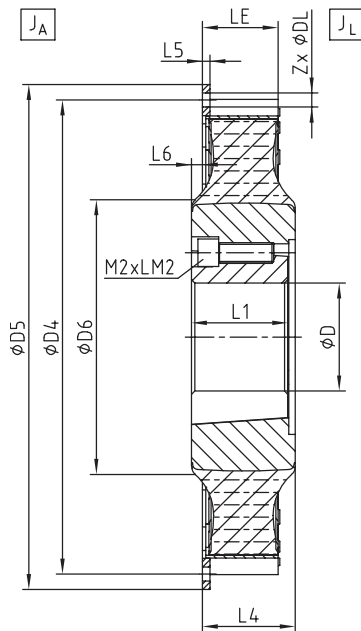

Type T specifies the hub type as Taperlock shaft connection

Flange dimensions according to SAE J620 [mm]				
Nominal size	D5	D4	Z	DL
11 1/2"	352.42	333.37	8	11
14"	466.72	438.15	8	13
18"	571.50	542.90	6	17
21"	673.10	641.35	12	17
24"	733.42	692.15	12	21
Ø475	475	450	12	11

SINULASTIC® type T																			
Size	Flange connection acc. to SAE - J620						Dimensions [mm]							Taper clamping sleeve		Mass moment of inertia [kgm <sup>2</sup> ] <sup>1)</sup>		Weight [kg] <sup>1)</sup>	
	11 1/2"	14"	18"	21"	24"	Ø475	Pilot bored	max.	D6	LE	L1	L4	L6	L7	M2xLM2	Type	JA		JL
20	●						35	90	164	60	63.5	70.5 +3.5/-4.5	5.5	41.0	1/2"x38	3525	0.0947	0.0568	13.75
		●												13.6			0.1353	0.0568	14.83
28		●					35	90	244	44	63.5	57.0 ± 3	7.0	7.0	1/2"x38	3525	0.1873	0.1919	24.37
			●														0.4968	0.1919	29.02
				●													0.2013	0.1919	24.63
38			●				40	110	244	58	76.2	70.0 ± 3	7.0	7.0	5/8"x44	4030	0.2444	0.2404	28.68
				●													0.5539	0.2404	33.33
					●												0.2584	0.2404	28.93
53				●			55	125	247	70	89.0	83.0 ± 3	13.0	7.0	3/4"x50	4535	0.2906	0.2993	33.72
					●												0.6000	0.2993	38.36
						●											0.3046	0.2993	33.97

<sup>1)</sup> With max. bore

Ordering example:	SINULASTIC® 38	T	MN	14	TL	Ø100
	Coupling size	Type	Elastomer type	Flange ØDA acc. to SAE or special	Hub type	Finish bore

**Description of product and application**

The VAROLASTIC® is a highly flexible flange coupling specifically designed for applications with variable load requirements. Its progressive torsion spring stiffness allows for optimum damping of vibrations, the drive systems being effectively protected against load peaks. It adapts automatically to different load conditions, thus optimising the vibration characteristics ensuring smooth operation.

The use of highly flexible elastomers (rollers) made of synthetical rubber (EPDM) dampens torsional vibrations and minimises shocks so that connected components are protected with temperatures of up to 120°C.

Due to its solid, compact design and the few components, the VAROLASTIC® reduces the maintenance effort and extends the service life of the overall drive train. It transmits the torque efficiently and prevents damaging axial or radial loads preserving bearing and other drive components.

Besides the standard version F it is optionally available as a failure protected version FD and prepared for the adaptation to different SAE connections.

The coupling is versatile convincing by its high power density under alternating operating conditions not only in mechanical and plant engineering.



Stiffness characteristic (progressive)

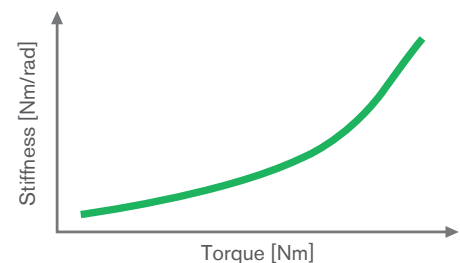

**VAROLASTIC® - The types**



**F**



**FD**

The two types of VAROLASTIC® F and VAROLASTIC® FD flange couplings differ in their anti-rotation feature. In the FD variant, this is achieved by a positive meshing (stop) within the coupling halves. In contrast to conventional solutions in the market, the coupling bound to direction of rotation stops before the rollers can be overloaded or destroyed. The functionality, as well as the coupling itself, is protected. Even in rare cases of overload, the drive can continue to be operated without restrictions.

**Properties of types by comparison**

Features	VAROLASTIC® F	VAROLASTIC® FD
Rated torques $T_{KN}$	According to series scale, usable range up to 100%, bound to direction of rotation	
Maximum torques $T_{KMax}$	$2x T_{KN}^{1)}$ / $3x T_{KN}^{2)}$	
Failure protection / Stop	No	Stop > $2x T_{KN}^{3)}$
Vibratory properties, e. g. torsional stiffness	non-linear, moderately progressive increase in torsional stiffness, high material damping and power loss	
Materials 1)	Synthetical EPDM up to 120°C permanent operating temperature for hardness ranges HE and UE	
Axial plug-in	Yes	Yes
Radial (dis) assembly	No	No
Mounting length	++	++
Displacement axial	+	∅
Displacement radial	∅	∅
Displacement angular	∅	∅
	For flywheel flange and shaft connection (SAE J620, DIN 5480 et seqq., DIN 6281, etc.)	

<sup>1)</sup> 100,000 load alternations

<sup>2)</sup> 1,000 load alternations

<sup>3)</sup> with room temperature

**Types of hubs**

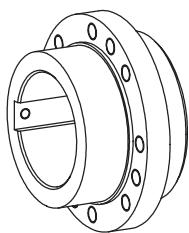

**Type 1.0**  
Hub with feather keyway and setscrew

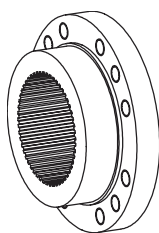

**Type 1.3**  
Hub with spline toothing

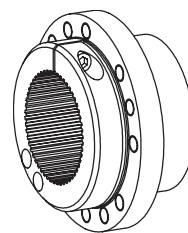

**Type 2.1**  
Clamping hub single slot with spline

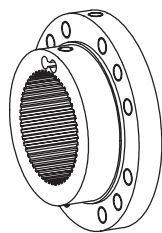

**Type 3.1**  
spline/clamping hub N

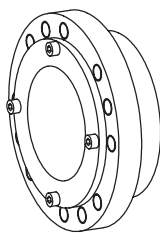

**Type 6.0**  
clamping ring hub

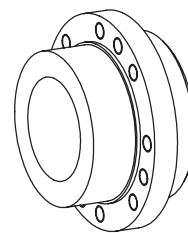

**Type 8.0**  
taper interference fit

**Type 8.1**  
cylindrical interference fit

Other hub types available on request.

**Displacements**

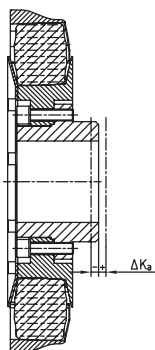

**Axial displacement**

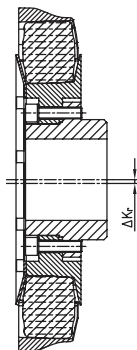

**Radial displacement**

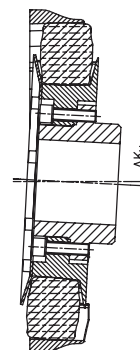

**Angular displacement**

Size	80	160	240	300	450	600
Perm. axial displacement $\Delta K_a$ [mm]	0.20	0.25	0.30	0.30	0.50	0.50
Perm. radial displacement $\Delta K_r$ [mm]	0.20	0.20	0.20	0.20	0.30	0.30
Perm. angular displacement $\Delta K_w$ [°]	0.15	0.15	0.20	0.20	0.25	0.25

Technical data																
Size	Elastomer type	Torque [Nm] <sup>1)</sup>				Dynamic torsion spring stiffness $C_{dyn}$ [Nm/rad]					Relative damping $\psi$ [-]		Perm. damping power $P_{KW}$ [W] <sup>2)</sup>		Operating speed [rpm]	
		$T_{KN}$	$T_{Kmax}$ 50.000 LA [Nm]	$T_{Kmax}$ 1.000 LA [Nm]	$T_{KW}$	10% $T_{KN}$	25% $T_{KN}$	50% $T_{KN}$	75% $T_{KN}$	100% $T_{KN}$	30 °C	80 °C	30 °C	80 °C	$n_t$	$n_{max}$
80	UE	800	1600	2400	400	1200	1700	4500	11500	24000			120	65	4500	5000
160	UE	1600	3200	4800	800	2500	5700	11000	24000	48000			200	110	4050	4500
240	UE	2400	4800	7200	1200	3800	7800	15000	35000	67000			250	140	3240	3600
300	UE	3000	6000	9000	1500	6000	10500	24000	52000	97000	1.6	1.17	350	190	2700	3000
450	UE	4500	9000	13500	2250	7000	12000	31000	71000	115000			530	270	2520	2800
600	UE	6000	12000	18000	3000	12000	19000	48000	104000	182000			600	320	2340	2600

<sup>1)</sup>  $T_{KN}$  Torque that can be continuously transmitted over the full speed range  
For selection consider DIN 740 part II (operating factor, temperature factor)  
<sup>2)</sup> Here permanent damping power. Twice the damping power figure is permissible for one hour.

# VAROLASTIC® F

highly flexible flange coupling with progressive torsion spring stiffness

## Pluggable roller coupling with optimised characteristic curve

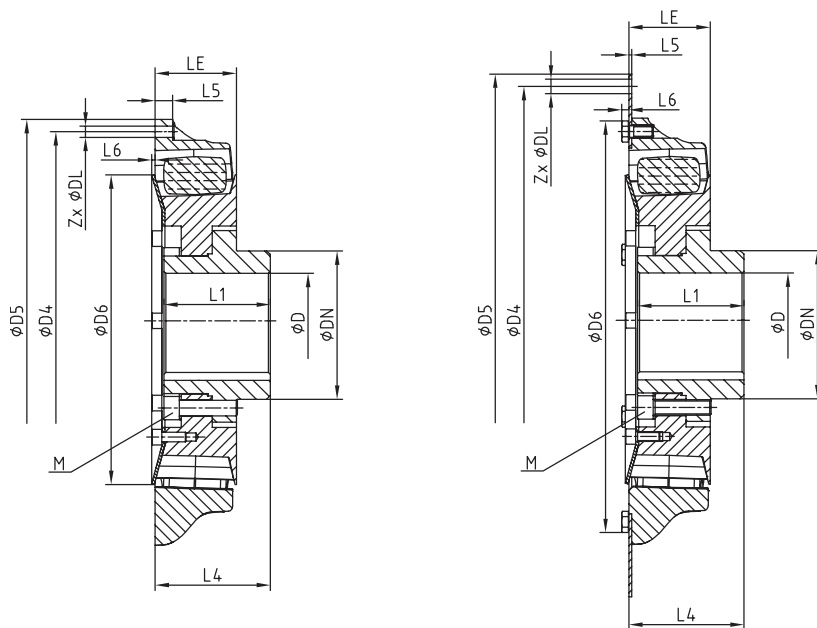
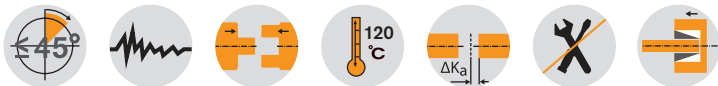
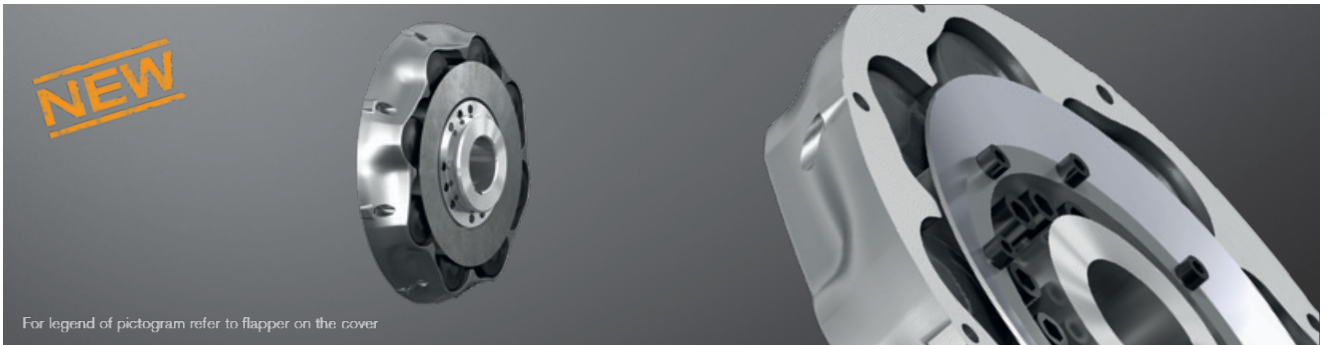

**Type A**  
(direct flange connection)

**Type B**  
(adaptive flange connection)

Flange dimensions according to SAE J620 [mm]				
Nominal size	D5	D4	Z	DL
8"	263.52	244.47	6	11
10"	314.32	295.27	8	11
11 1/2"	352.42	333.37	8	11
14"	466.72	438.15	8	13
18"	571.50	542.90	6	17

VAROLASTIC® type F																			
Size	Bore D [mm]	Type	Flange connection acc. to SAE - J620					Dimensions [mm]							Cap screws DIN EN ISO 4762		Mass moment of inertia [kgm <sup>2</sup> ] <sup>1)</sup>		Weight [kg] <sup>1)</sup>
			8"	10"	11 1/2"	14"	18"	DN	D6	LE	L1	L4	L6	L7	M	T <sub>A</sub> in Nm	J <sub>A</sub>	J <sub>L</sub>	
80	50	A	●					70	175	49	50	57	6.5	21	M8	32	0.0220	0.0100	4.84
		B		●				70	264					1.8			0.0330	0.0100	5.49
160	70	A		●				100	234					22	M12	100	0.0360	0.0730	8.88
		B			●			100	315	51	70	75	6.5	3			0.0590	0.0730	9.81
240	60	A			●			85	227				2	22	M12	100	0.0807	0.0377	11.23
		B				●		85	353	66	65	82	6.5	3			0.1706	0.0377	13.55
300	80	A			●			112	263				6	26	M12	100	0.0829	0.0648	12.80
		B				●		112	353	65	75	83	6.5	3			0.1719	0.0648	15.08
450	90	A				●		124	300	84	90	99	3.8	21.5	M16	240	0.2844	0.1544	26.96
600	110	A				●		162	338				3.7	19.5	M16	240	0.3022	0.2344	28.86
		B					●	162	460	85	110	119	7.5	3			0.4876	0.2344	31.91

<sup>1)</sup> With max. bore

Ordering example:	VAROLASTIC® 600	F	14"	2.7	DIN 5480 - 60x2x28
	Coupling size	Type	Motor flange	Hub type	Finish bore

# VAROLASTIC® F

highly flexible flange coupling with progressive torsion spring stiffness

## Pluggable roller coupling with optimised characteristic curve

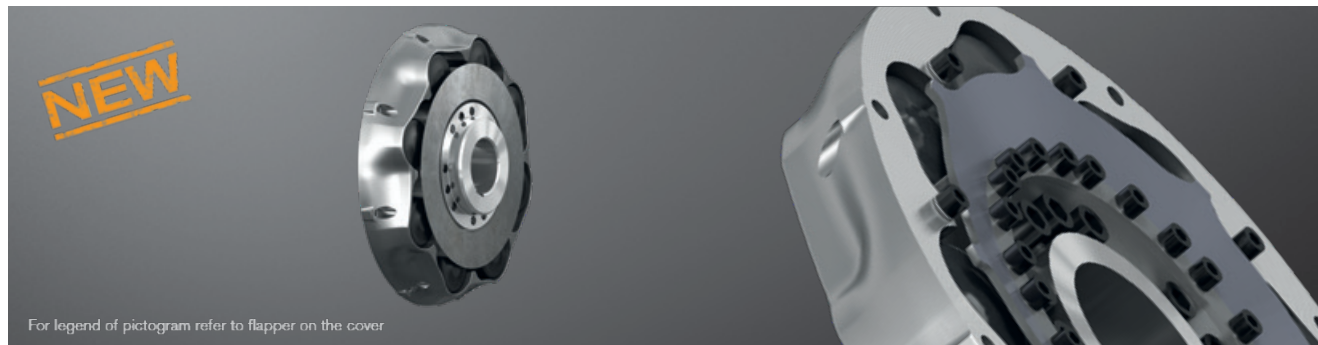

For legend of pictogram refer to flapper on the cover

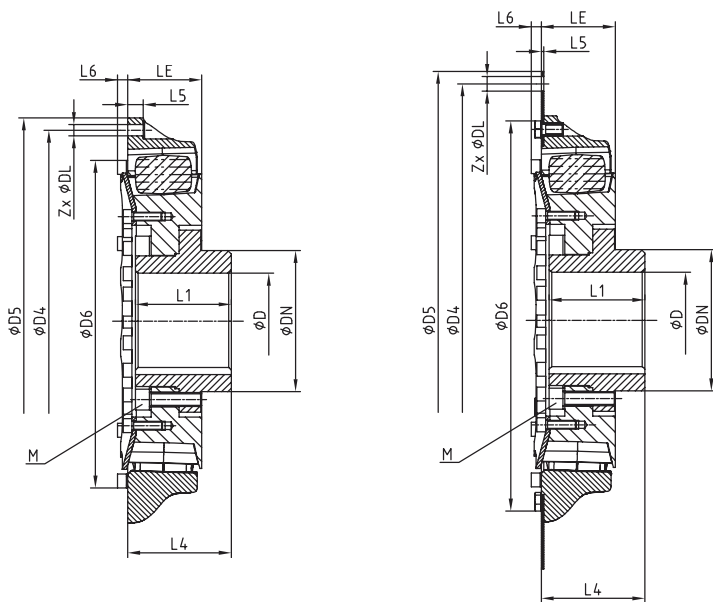
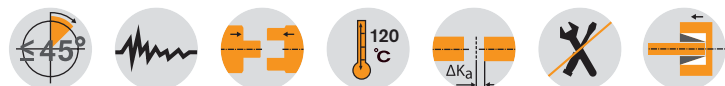

**Type C**  
(direct flange connection)

**Type D**  
(adaptive flange connection)

Flange dimensions according to SAE J620 [mm]				
Nominal size	D5	D4	Z	DL
8"	263.52	244.47	6	11
10"	314.32	295.27	8	11
11 1/2"	352.42	333.37	8	11
14"	466.72	438.15	8	13
18"	571.50	542.90	6	17

VAROLASTIC® type FD																			
Size	Bore D [mm]	Type	Flange connection acc. to SAE - J620					Dimensions [mm]							Cap screws DIN EN ISO 4762		Mass moment of inertia [kgm <sup>2</sup> ] <sup>1)</sup>		Weight [kg] <sup>1)</sup>
			8"	10"	11 1/2"	14"	18"	DN	D6	LE	L1	L4	L6	L7	M	T <sub>A</sub> in Nm	J <sub>A</sub>	J <sub>L</sub>	
80	50	C	•				70	213	49	50	57	9.2	21	M8	32	0.0223	0.0120	5.41	
		D		•		264		1.8					0.0339			0.0120	6.06		
160	70	C		•			100	273	51	70	75	9.2	22	M12	100	0.0370	0.0450	9.76	
		D			•	314		3					0.0699			0.0450	10.69		
240	60	C			•		85	271	66	65	82	9.5	22	M12	100	0.0834	0.0452	12.31	
		D			•	353		3					0.1732			0.0452	14.62		
300	80	C			•		112	311	65	75	83	11.5	26	M12	100	0.0875	0.0815	14.43	
		D			•	353		3					0.1766			0.0815	16.71		
450	90	C				•	124	351	84	90	99	11.5	21.5	M16	240	0.2896	0.1744	26.49	
		D			•	383		3.7					19.5			0.3095	0.2781		31.27
600	110	C				•	162	460	85	110	119	7.5	3	M16	240	0.4949	0.2781	34.32	
		D			•														

<sup>1)</sup> With max. bore

Ordering example:	VAROLASTIC® 300	FD	11.5"	1.0	Ø60
	Coupling size	Type	Motor flange	Hub type	Finish bore

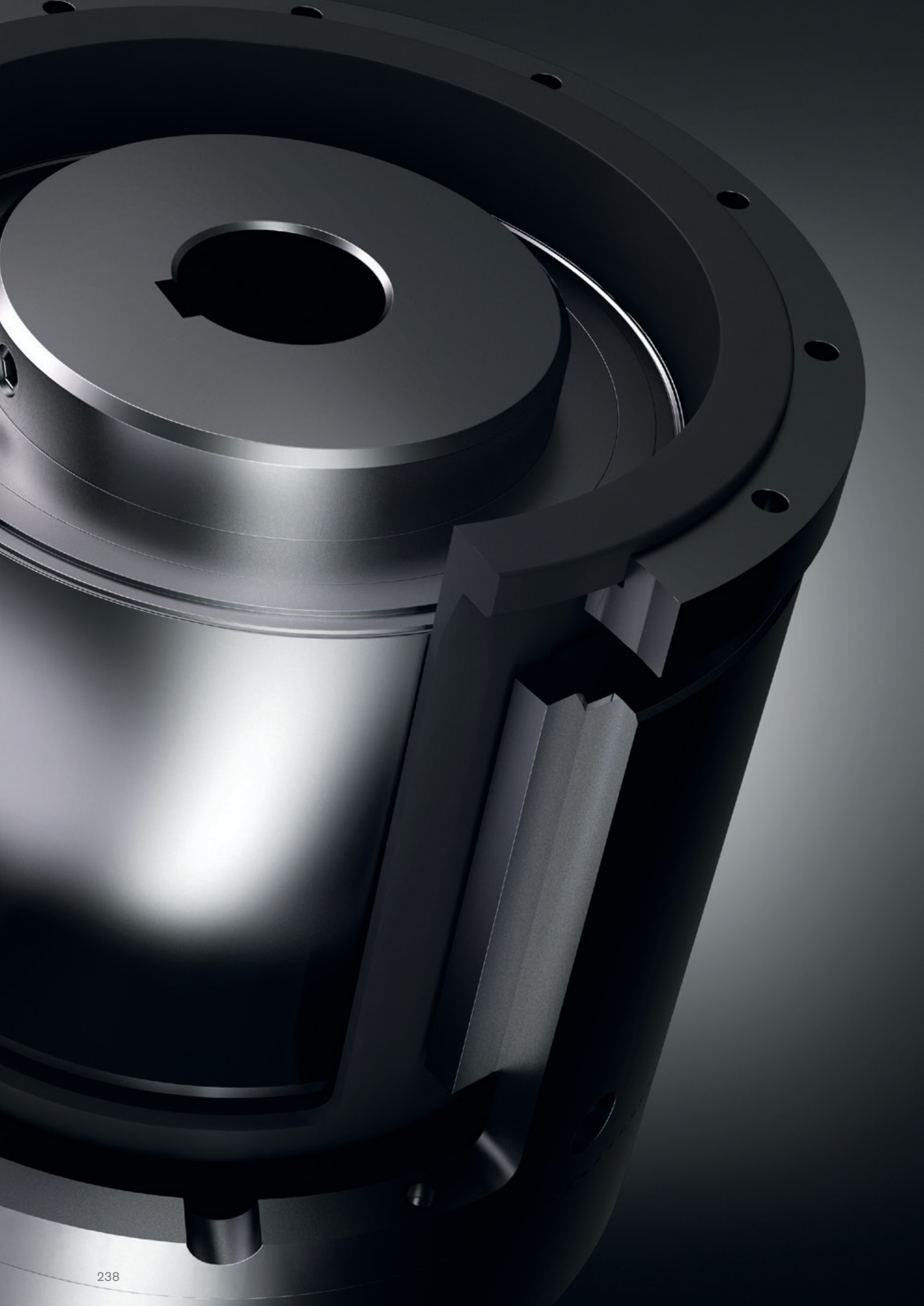

# Magnetic couplings

Types and operating description 240

---

## MINEX®-S

Containment shroud – material stainless steel	242
Containment shroud – material Hastelloy	244
Containment shroud – material PEEK	246
Containment shroud – material oxide ceramics	248
Conversion kits and customised subassemblies	250
Other types	251

---

## MINEX®-H

Hysteresis coupling 252

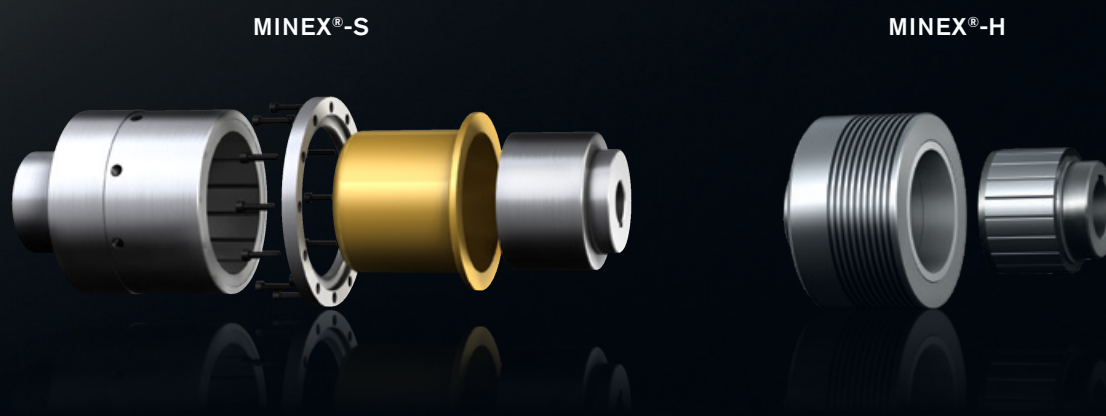

# MAGNETIC COUPLINGS

## TYPES AND OPERATING DESCRIPTION

### General information



#### General description

MINEX<sup>®</sup>-S magnetic couplings transmit the torque without contact through magnetic forces between the internal and external rotor. They ensure hermetic separation between driving and driven side in pumps and agitators sealing hazardous liquids and gases reliably. As a result they prevent serious leakages operating as a reliable alternative to usual dynamic shaft seals.

Internal rotor



External rotor



Run of flux lines

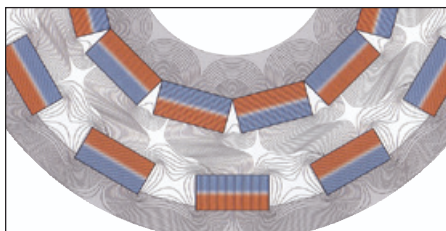

#### Operation/Design

The coupling consists of an external and an internal rotor. The external rotor has high-quality, permanent magnets of changing polarity on the inner side while the internal rotor has got them on the outside.

The external rotor is usually fixed on the drive side and the magnets are bonded in the keyways. The magnets of the internal rotor on the driven side are fully encapsulated.

#### Torque transmission

In their non-operative states the north and south poles of the rotors face each other and the magnetic field is completely symmetric. It is only when the rotors are twisted that the magnetic field lines are deflected, hence the torque is transmitted through the air gap. Then there is a synchronous operation under a constant torsion angle. If the maximum coupling torque and the maximum torsion angle are exceeded, the power transmission is interrupted.

Containment shroud



#### Sealing function

The containment shroud that is fixed on the housing separates internal and external rotor from each other.

It ensures a completely leak-proof separation of product space and atmosphere.

The sealing is made statically, e. g. with a flat gasket or an O-ring, thus eliminating the need to use dynamically loaded sealing elements.

As a standard KTR supplies both metallic and non-metallic containment shrouds.

The metallic types cover the widest application range, yet causing eddy current losses which might require cooling measures. If eddy current losses can be entirely excluded, the energy-efficient alternative materials PEEK and ceramics are available.

#### Use in potentially explosive atmospheres

MINEX<sup>®</sup> couplings are suitable for power transmission in drives in potentially explosive atmospheres. The types with metallic, ceramic and PEEK containment shrouds are assessed and approved as components of category II according to EU directive 2014/34/EU and thus suitable for the use in potentially explosive atmospheres of zone 2G.



Please read through our information included in the respective type examination certificate and the operating and assembly instructions at [www.ktr.com](http://www.ktr.com).

# MAGNETIC COUPLINGS

## TYPES AND OPERATING DESCRIPTION

### Properties of magnetic couplings

Product	Type with metallic containment shroud	Type with containment shroud made of PEEK CFRP	Type with containment shroud made of oxide ceramics
Type	Permanent-magnetic synchronous coupling		
<b>Properties</b>			
Permanent-magnetic	●	●	●
Contactless	●	●	●
Maintenance-free	●	●	●
Torsionally flexible	●	●	●
Low-vibration	●	●	●
<b>Special features/applications</b>			
	most common type covering the widest performance range particularly suitable for pump drives/ applications with liquids high $t_{max}$ [°C] and $p_{max}$ [bar]	no eddy current losses energy-efficient and economic particularly suitable for dry running	
		for medium requirements on $t_{max}$ [°C] and $p_{max}$ [bar]	high $t_{max}$ [°C] and $p_{max}$ [bar]
<b>Torque range <math>T_{KN}</math> [Nm]</b>			
Max.	1,000	600	600
<b>Max. pressure resistance [bar]</b>			
$p_{max}$ .	up to 90 bars depending on size	up to 16 bars with 130 °C	up to 40 bars depending on size
<b>Geometries</b>			
shaft diameter min./max. [mm]	Ø5 pilot bored	Ø5 pilot bored	Ø5 pilot bored
<b>Max. temperature resistance [°C]</b>			
$t_{max}$ .	150/300 depending on magnet material	130	300
<b>Certifications/type examinations</b>			
ATEX 	●	CFRP reinforcement ●	GRP reinforcement ●
	for further details see catalogue pages 250 - 253	for further details see catalogue pages 254 - 255	

### Torque reduction with temperature increase

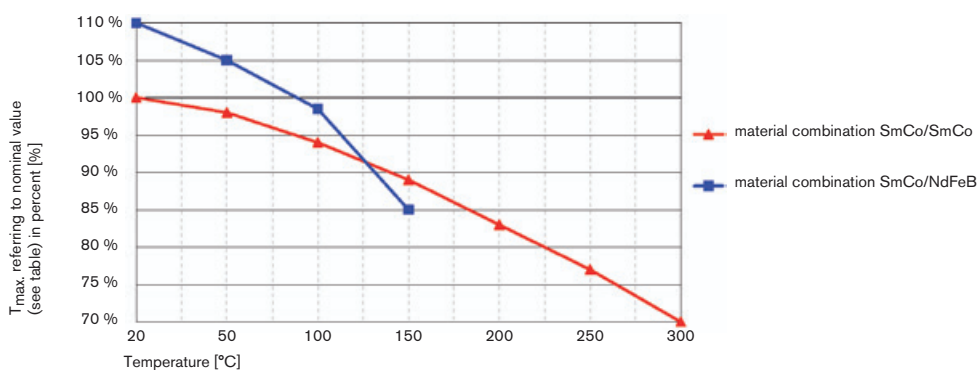

Temporary torque reduction with increased temperature for alternative material combinations [%].

#### Please note:

KTR recommends to use NdFeB magnets for the external rotor, provided that the operating temperature falls below 150 °C.

# MINEX®-S Magnetic couplings

## Containment shroud – material stainless steel

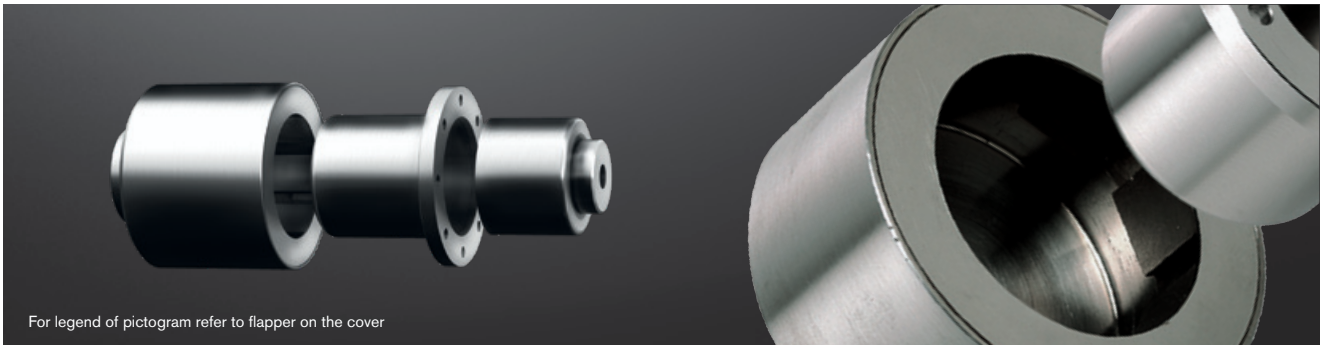

For legend of pictogram refer to flapper on the cover

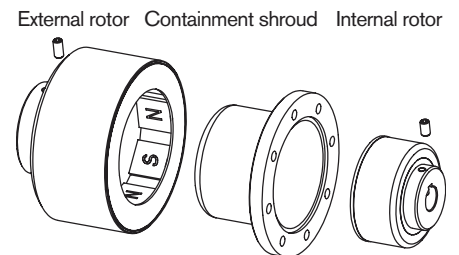
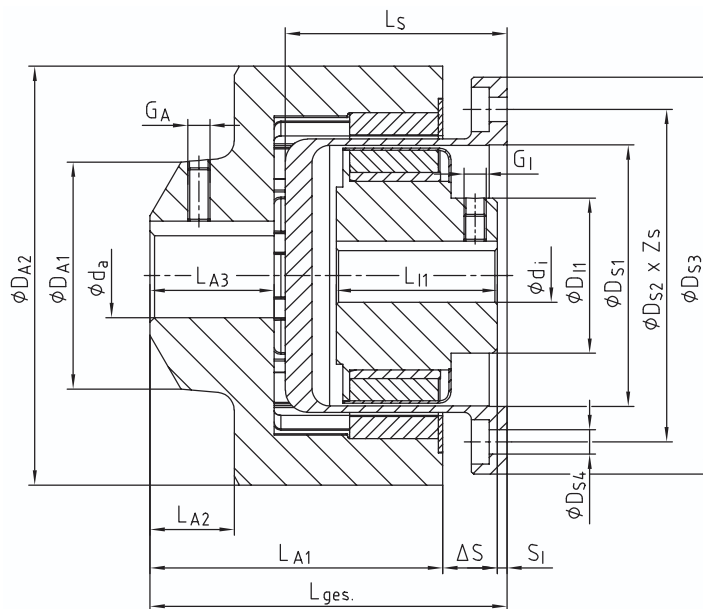

Technical data – Internal rotor and containment shroud														
Size	TK max [Nm] with 20 °C	Dimensions [mm]												
		Internal rotor						Containment shroud						
		Finish bore <sup>1)</sup> d <sub>i</sub>		D <sub>I1</sub>	L <sub>I1</sub>	G <sub>I</sub>	S <sub>I</sub>		D <sub>S1</sub>	D <sub>S2</sub>	D <sub>S3</sub>	D <sub>S4</sub>	Z <sub>S</sub>	L <sub>S</sub>
min.	max.	min.	max.											
SA 22/4	0.15	5	9	20	20	M 3	2.0	2.0	21.5	38	46	4.5	8	29
SA 34/10	1	5	12	20	22	M 3	2.0	5.5	34	46	55	4.5	4	30.5
SA 46/6	3	8	16	28	33	M 4	6.5	7.0	46	64	78	4.5	8	45
SA 60/8	7	12	22	35	36.3	M 5	1.7	5.5	59	75	83.5	5.5	8	50
SB 60/8	14			36	56	M 5	0.0	4.0			89			70.3
SC 60/8	22	12	24	36	76	M 5	0.0	4.0	59	75	89.5	5.5	8	90

Technical data – External rotor and general												
Size	Dimensions [mm]											
	External rotor									General		
	Finish bore <sup>1)</sup> d <sub>a</sub>		D <sub>A1</sub>	D <sub>A2</sub>	G <sub>A</sub>	L <sub>A1</sub>	L <sub>A2</sub>	L <sub>A3</sub>	ΔS	L <sub>total</sub>		
min.	max.	min.								max.		
SA 22/4	5	11	18	38	M 4	35	8.5	11	5	42	42	
SA 34/10	5	14	22	53	M 4	38.8	10.5	13	5.3	46	49.5	
SA 46/6	5	24	40	69.5	M 5	53	16	22	9	69	69.5	
SA 60/8	9	32	50	94.5	M 6	66	19	28	12	105.2	83.3	
SB 60/8	9	38			M 8	93.3	15	30				
SC 60/8	9	38	60	94.5	M 8	113.3	15	30	12	125.2	129.2	

<sup>1)</sup> Bores H7 with keyway to DIN 6885 sheet 1 [JS9]

Ordering example:	MINEX® SA 60/8	NdFeB	d <sub>i</sub> Ø20 mm	d <sub>a</sub> Ø24 mm
	Coupling size	NdFeB – t <sub>max.</sub> = 150 °C Sm2Co17 – t <sub>max.</sub> = 300 °C	Finish bore (H7), feather keyway acc. to DIN 6885 sheet 1 (JS9)	

## Examples of application

MINEX® couplings with containment shroud made of stainless steel are the most common type for pump drives and other applications with liquids in the lower performance range. Subject to their high resistance to pressure and temperature they cover a wide application range. The magnetic rotors are available from stock in an unbored or pilot bored design. If requested, the parts can be finish bored according to ISO fit H7 and provided with feather keyway to DIN 6885 sheet 1 [JS9].

Inside the rotating magnetic field metallic containment shrouds generally cause losses of eddy current which are converted into heat and which may require cooling measures. On applications with pumps the generated heat can usually be dissipated by the medium to be pumped. If higher pressure resistance than covered by the KTR standard is required, KTR provides for customised special solutions.

Typical applications: gear pumps, centrifugal pumps, screw spindle pumps, agitators, PU foaming lines

## Use in potentially explosive atmospheres

MINEX® couplings with containment shroud made of stainless steel are suitable for power transmission in drives used in potentially explosive atmospheres. They are assessed and approved as components of category II according to EU directive 2014/34/EU and thus suitable for the use in potentially explosive atmospheres of zone 2G.

If the couplings operate in potentially explosive atmospheres, the user has to provide for special measures. Please read through our information included in the respective type examination certificate and the operating and assembly instructions at [www.ktr.com](http://www.ktr.com).



Technical data – Materials, temperature and pressure resistance										
Size	TK max [Nm] with 20 °C	Internal rotor			Containment shroud			External rotor (+ flange hub optionally)		
		Standard material		Max. temperature	Standard material		Max. pressure	Standard material		Max. temperature
		Hub	Magnets	t <sub>max.</sub> [°C]	Hub	Cont. shroud	P <sub>N</sub> /P <sub>max.</sub> [bar]	Hub	Magnets	t <sub>max.</sub> [°C]
SA 22/4	0.15	1.4462	NdFeB	150	1.4571	1.4571	60/90	S355J2	NdFeB	150
SA 34/10	1	1.4462	NdFeB	150	1.4571	1.4571	16/24	S355J2	NdFeB	150
SA 46/6	3	1.4571	Sm2Co17	300	1.4571	1.4571	16/24	S355J2	Sm2Co17	300
SA 60/8	7	1.4571	Sm2Co17	300	1.4571	1.4571	40/60	S355J2	Sm2Co17*	300
SB 60/8	14	1.4571	Sm2Co17	300	1.4571	1.4571	40/60	S355J2	Sm2Co17*	300
SC 60/8	22	1.4571	Sm2Co17	300	1.4571	1.4571	40/60	S355J2	Sm2Co17*	300

\*) External rotor alternatively available with magnets made of NdFeB (t<sub>max.</sub> = 150 °C).

# MINEX®-S Magnetic couplings

## Containment shroud – material Hastelloy

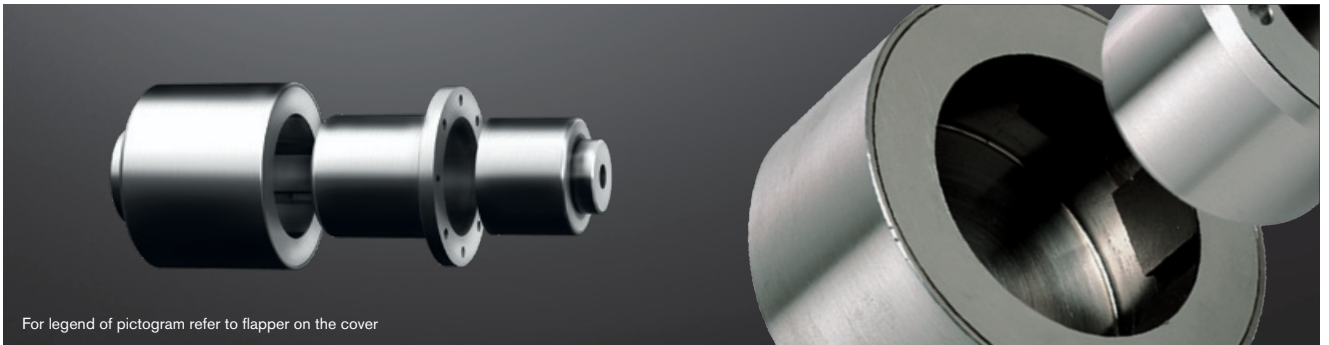

For legend of pictogram refer to flapper on the cover

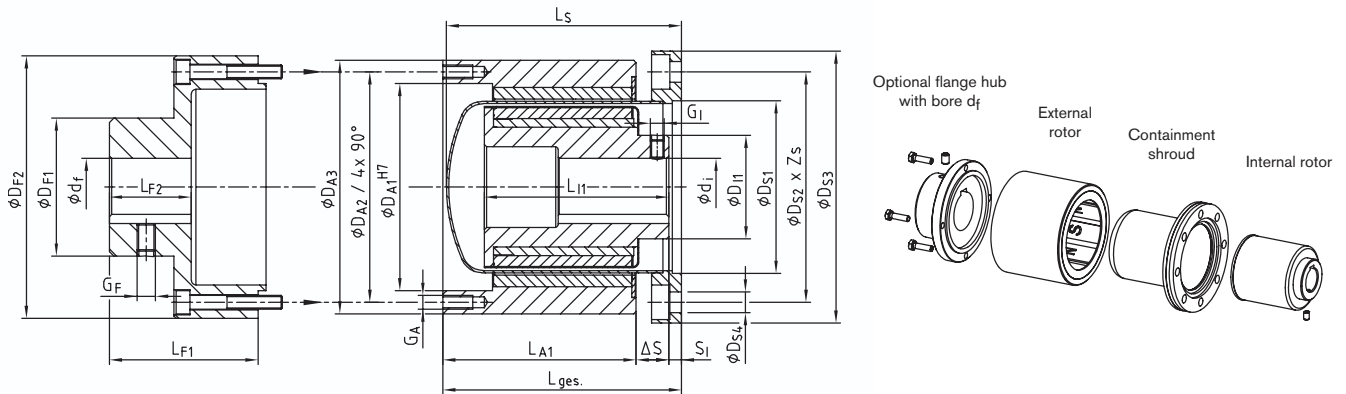

### Technical data – Materials, temperature and pressure resistance

Size	$T_K \text{ max [Nm]}$ with 20 °C	Internal rotor		Containment shroud			External rotor (+ flange hub optionally)			
		Standard material		Max. temperature	Standard material		Max. pressure	Standard material		Max. temperature
		Hub	Magnets	$t_{\text{max. [}^\circ\text{C]}$	Hub	Cont. shroud	$P_N/P_{\text{max. [bar]}$	Hub	Magnets	$t_{\text{max. [}^\circ\text{C]}$
SA 75/10	10	1.4571	Sm2Co17	300	1.4571	2.4602**	25/37.5	S355J2	Sm2Co17*	300
SB 75/10	24	1.4571	Sm2Co17	300	1.4571	2.4602**	25/37.5	S355J2	Sm2Co17*	300
SC 75/10	40	1.4571	Sm2Co17	300	1.4571	2.4602**	25/37.5	S355J2	Sm2Co17*	300
SB 110/16	60	1.4571	Sm2Co17	300	1.4571	2.4856	25/37.5	S355J2	Sm2Co17*	300
SC 110/16	95	1.4571	Sm2Co17	300	1.4571	2.4856	25/37.5	S355J2	Sm2Co17*	300
SB 135/20	100	1.4571	Sm2Co17	300	1.4571	2.4856	25/37.5	S355J2	Sm2Co17*	300
SC 135/20	145	1.4571	Sm2Co17	300	1.4571	2.4856	25/37.5	S355J2	Sm2Co17*	300
SD 135/20	200	1.4571	Sm2Co17	300	1.4571	2.4856	25/37.5	S355J2	Sm2Co17*	300
SC 165/24	210	1.4571	Sm2Co17	300	1.4571	2.4856	25/37.5	S355J2	Sm2Co17	300
SD 165/24	280	1.4571	Sm2Co17	300	1.4571	2.4856	25/37.5	S355J2	Sm2Co17	300
SE 165/24	370	1.4571	Sm2Co17	300	1.4571	2.4856	25/37.5	S355J2	Sm2Co17	300
SD 200/30	460	1.4571	Sm2Co17	300	1.4571	2.4856	16/24	S355J2	Sm2Co17	300
SE 200/30	600	1.4571	Sm2Co17	300	1.4571	2.4856	16/24	S355J2	Sm2Co17	300
SD 250/38	670	1.4571	Sm2Co17	300	1.4571	2.4856	12/18	S355J2	Sm2Co17	300
SE 250/38	820	1.4571	Sm2Co17	300	1.4571	2.4856	12/18	S355J2	Sm2Co17	300
SF 250/38	1000	1.4571	Sm2Co17	300	1.4571	2.4856	12/18	S355J2	Sm2Co17	300

\*) External rotor alternatively available with magnets made of NdFeB ( $t_{\text{max.}} = 150 \text{ }^\circ\text{C}$ ).

\*\*) Containment shroud size 75 alternatively available made of stainless steel 1.4571 ( $P_N/P_{\text{max}} = 16/24 \text{ bars}$ )

Ordering example:	MINEX® SB 75/10	NdFeB	$d_i \text{ } \phi 20 \text{ mm}$	$d_a \text{ } \phi 24 \text{ mm}$	Hastelloy
	Coupling size	NdFeB – $t_{\text{max.}} = 150 \text{ }^\circ\text{C}$ Sm2Co17 – $t_{\text{max.}} = 300 \text{ }^\circ\text{C}$	Finish bore (H7), feather keyway acc. to DIN 6885 sheet 1 (JS9)		Containment shroud type Stainless steel 1.4571 or Hastelloy

### Examples of application

MINEX® couplings with containment shroud made of Hastelloy are the most common type for pump drives and other applications with liquids in the medium and higher performance range. Subject to their high resistance to pressure and temperature they cover a wide application range.

Inside the rotating magnetic field metallic containment shrouds generally cause losses of eddy current which are converted into heat and which may require cooling measures. On applications with pumps the generated heat can usually be dissipated by the medium to be pumped. If higher pressure resistance than covered by the KTR standard is required, KTR provides for customised special solutions.

Typical applications: gear pumps, centrifugal pumps, screw spindle pumps, agitators, PU foaming lines

### Use in potentially explosive atmospheres

MINEX® couplings with containment shroud made of Hastelloy are suitable for power transmission in drives used in potentially explosive atmospheres. They are assessed and approved as components of category II according to EU directive 2014/34/EU and thus suitable for the use in potentially explosive atmospheres of zone 2G.

If the couplings operate in potentially explosive atmospheres, the user has to provide for special measures. Please read through our information included in the respective type examination certificate and the operating and assembly instructions at [www.ktr.com](http://www.ktr.com).



Technical data – External rotor and general																												
Size	Dimensions [mm]																											
	Internal rotor						Containment shroud						External rotor						Flange hub						General			
	Finish bore <sup>1)</sup>		D <sub>I1</sub>	L <sub>I1</sub>	G <sub>I</sub>	S <sub>I</sub>		D <sub>S1</sub>	D <sub>S2</sub>	D <sub>S3</sub>	D <sub>S4</sub>	Z <sub>S</sub>	L <sub>S</sub>	D <sub>A1</sub>	D <sub>A2</sub>	D <sub>A3</sub>	L <sub>A1</sub>	G <sub>A</sub>	d <sub>f</sub> max.	D <sub>F1</sub>	D <sub>F2</sub>	L <sub>F1</sub>	L <sub>F2</sub>	G <sub>F</sub>	ΔS	Total length <sup>2)</sup> (with flange hub)		
	d <sub>i</sub> min.	d <sub>i</sub> max.				min.	max.																			min.	max.	min.
SA 75/10			39.5			46.5										41.3									12.2	140	164.5	
SB 75/10	12	32	45	58	M 6	4	26.5	75	100	118	9	8	102	90	100	110	61.3	M 6	42	60	114	64.5	35.5	M 8	14.2	166.5	166.5	
SC 75/10			80			4.0										83.8												
SB 110/16			65			35.0										61.3									18.7	183.5	214.5	
SC 110/16	14	55	80	85	M 8	4	15.0	110	133	153	9	12	115	126	135	145	81.3	M 6	55	85	150	99.5	59.5	M 10	18.7	203.5	214.5	
SB 135/20			65			50.5										70.3									18.2	190.5	204.5	
SC 135/20	20	70	90	85	M 10	4	30.5	135	158	178	9	16	139	150	160	170	90.3	M 6	70	100	170	65.5	48.5	M 12	20.7	200.5	204.5	
SD 135/20			110			8.0										110.3									20.7	233	247	
SC 165/24			85			61.5										90.3										18.2	233	247
SD 165/24	24	80	110	110	M 12	6	39.0	163.5	192	218	11	12	170	180	188	198	110.3	M 6	75	110	198	77	60	M 16	20.7	233	247	
SE 165/24			130			19.0										130.3										20.7	234	247
SD 200/30			24.0			24.0	200	252	278	11	12	180	212	222	232	130.3	M 6	80	120	232	120	98	M 12	25.7	282	300		
SE 200/30	38	90	130	135	M 16	6	24.0	200	252	278	11	12	180	212	222	232	130.3	M 6	80	120	232	120	98	M 12	25.7	282	300	
SD 250/38			115			46.0										110.3											282	322
SE 250/38	38	100	165	135	M 16	6	26.0	255	285	315	13.5	12	182	272	282	292	130.3	M 6	100	150	300	140	93	M 16	25.7	302	322	
SF 250/38			155			6.0										150.3											322	322

<sup>1)</sup> Bores H7 with keyway to DIN 6885 sheet 1 [JS9]  
<sup>2)</sup> Total length without flange hub = L<sub>S</sub>

# MINEX®-S

## Magnetic couplings

### Containment shroud – material PEEK

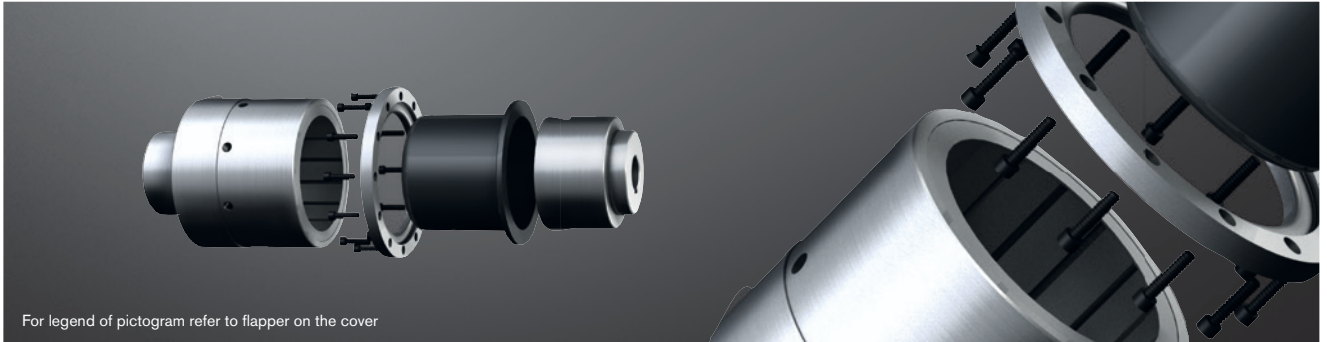

For legend of pictogram refer to flapper on the cover

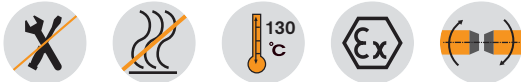

Technical data – Internal rotor and containment shroud														
Size	T <sub>K</sub> max [Nm] with 20 °C	Dimensions [mm]												
		Internal rotor						Containment shroud						
		Finish bore D <sup>1)</sup>		DN	L1	E		G	D5	D4	DA	DL	S	L <sub>S</sub> = L <sub>g</sub> <sup>2)</sup>
		min.	max.			min.	max.							
SA 75/10	10	12	32	45	39,5	30,5	54,5	M6	75	100	118	9,0	8	108
SB 75/10	24	12	32	45	58	8,5	34,5	M6	75	100	118	9,0	8	108
SC 75/10	40	12	32	45	80	5,5	10,0	M6	75	100	118	9,0	8	108
SD 75/10	70	12	32	45	90	2,5	2,5	M6	75	100	118	9,0	8	108
SB 110/16	70	14	55	80	65	4	26,0	M8	140	151	168	9,0	12	115
SC 110/16	100	14	55	80	85	4	6,0	M8	140	151	168	9,0	12	115
SB 135/20	110	20	70	90	65	4	48,0	M10	157	167	180	6,6	12	144
SC 135/20	155	20	70	90	85	4	28,0	M10	157	167	180	6,6	12	144
SD 135/20	210	20	70	90	110	4	4,0	M10	157	167	180	6,6	12	144
SC 165/24	220	24	80	110	85	4	32,0	M12	196	210	228	9,0	12	156
SD 165/24	300	24	80	110	110	4	8,0	M12	196	210	228	9,0	12	156
SE 165/24	390	24	80	110	130	-5	-5,0	M12	196	210	228	9,0	12	165
SD 200/30	460	38	100	130	135	2	4,0	M16	229	246	265	9,0	12	183
SE 200/30	600	38	100	130	135	2	4,0	M16	229	246	265	9,0	12	183

Technical data – External rotor, flange hub and general														
Size	Dimensions [mm]													
	External rotor					Flange hub					General			
	D10	D9	D7	M	L7	Max. finish bore		DH	L2	L3	G1	W	Total length <sup>2)</sup>	
						D1 <sup>1)</sup>	DN1						min.	max.
SA 75/10	90	100	110	M6	41,3	42	60,0	114	64,5	35,5	M6	12,2	148,5	172,5
SB 75/10	90	100	110	M6	61,3	42	60,0	114	64,5	35,5	M6	12,2	146,5	173,5
SC 75/10	90	100	110	M6	83,9	42	60,0	114	64,5	35,5	M6	14,2	168	176
SD 75/10	90	100	110	M6	91	42	60,0	114	64,5	35,5	M6	14,2	172,2	172,2
SB 110/16	130	138	150	M6	61,3	55	85,0	153	87,5	45,5	M10	18,7	172,5	192,5
SC 110/16	130	138	150	M6	81,3	55	85,0	153	87,5	45,5	M10	18,7	189,5	192,5
SB 135/20	158	167	176	M6	70,3	70	100,0	176	89	67	M12	18,2	216	225,5
SC 135/20	158	167	176	M6	90,3	70	100,0	176	89	67	M12	18,2	216	225,5
SD 135/20	158	167	176	M6	110,3	70	100,0	176	89	67	M12	20,7	224	224
SC 165/24	186	195	204	M6	90,3	75	110,0	204	94	70	M16	18,5	231	234,8
SD 165/24	186	195	204	M6	110,3	75	110,0	204	94	70	M16	20,7	231	233,3
SE 165/24	186	195	204	M6	130,3	75	110,0	204	94	70	M16	20,7	245,3	245,3
SD 200/30	220	230	240	M6	130,3	90	120,0	240	120	88	M16	25,7	288	288
SE 200/30	220	230	240	M6	130,3	90	120,0	240	120	88	M16	25,7	288	288

<sup>1)</sup> Bores H7 with keyway to DIN 6885 sheet 1 [JS9]

<sup>2)</sup> Total length without flange hub = L<sub>S</sub>

Technical data										
Size	T <sub>M</sub> max [Nm] with 20 °C	Internal rotor			Containment shroud			External rotor (+ flange hub optionally)		
		Standard material		Max. temperature t <sub>max.</sub> [°C]	Standard material		Max. pressure P <sub>N</sub> [bar]	Standard material		Max. temperature t <sub>max.</sub> [°C]
		Hub	Magnets		Clamping ring	Cont. shroud		Hub	Magnets	
SA 75/10	10	1.4571	Sm2Co17	300	-	PEEK	16	S355J2	Sm2Co17	130
SB 75/10	24	1.4571	Sm2Co17	300	-	PEEK	16	S355J2	Sm2Co17	130
SC 75/10	40	1.4571	Sm2Co17	300	-	PEEK	16	S355J2	Sm2Co17	130
SD 75/10	70	1.4571	Sm2Co17	300	-	PEEK	16	S355J2	Sm2Co17	130
SB 110/16	70	1.4571	Sm2Co17	300	Aluminium	PEEK	16	S355J2	Sm2Co17	130
SC 110/16	100	1.4571	Sm2Co17	300	Aluminium	PEEK	16	S355J2	Sm2Co17	130
SB 135/20	110	1.4571	Sm2Co17	300	Aluminium	PEEK	16	S355J2	Sm2Co17	130
SC 135/20	155	1.4571	Sm2Co17	300	Aluminium	PEEK	16	S355J2	Sm2Co17	130
SD 135/20	210	1.4571	Sm2Co17	300	Aluminium	PEEK	16	S355J2	Sm2Co17	130
SC 165/24	220	1.4571	Sm2Co17	300	Aluminium	PEEK	16	S355J2	Sm2Co17	130
SD 165/24	300	1.4571	Sm2Co17	300	Aluminium	PEEK	16	S355J2	Sm2Co17	130
SE 165/24	390	1.4571	Sm2Co17	300	Aluminium	PEEK	16	S355J2	Sm2Co17	130
SD 200/30	460	1.4571	Sm2Co17	300	Aluminium	PEEK	16	S355J2	Sm2Co17	130
SE 200/30	600	1.4571	Sm2Co17	300	Aluminium	PEEK	16	S355J2	Sm2Co17	130

Ordering example:	MINEX® SB 75/10	NdFeB	d <sub>i</sub> Ø20 mm	d <sub>a</sub> Ø24 mm	PEEK
	Coupling size	NdFeB – t <sub>max.</sub> = 150 °C	Finish bore (H7), feather keyway acc. to DIN 6885 sheet 1 (JS9)		Containment shroud type

## Examples of application

MINEX® couplings with containment shroud made of PEEK are an economic, energy-efficient alternative to the metallic types. They do not generate any eddy current losses and as a result do not generate any heat so that usually expensive cooling measures can be done without. Moreover, they are characterized by low susceptibility to fracture, low weight and easy handling.

They are ideally suitable for applications with low demands on temperature and pressure resistance.

Typical applications: vacuum pumps, fan drives, compressors, agitators, PU foaming lines

## Dimensions - SA 75/10 to SD 75/10 with one-piece containment shroud

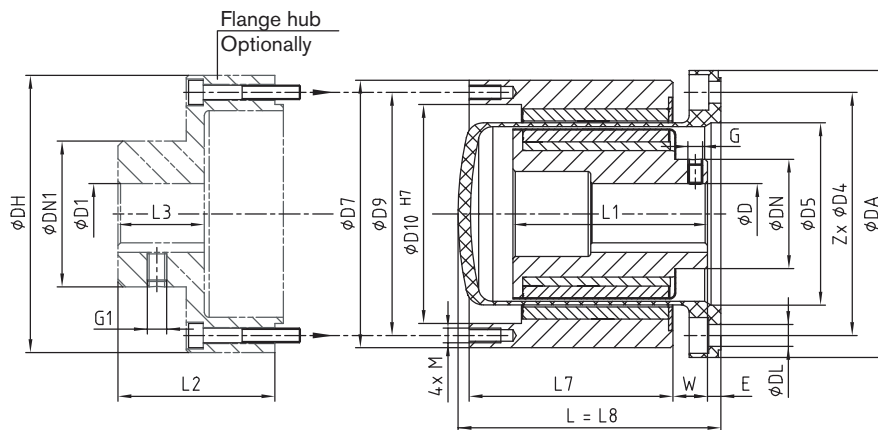

## Dimensions: SA 110/16 to SE 200/30

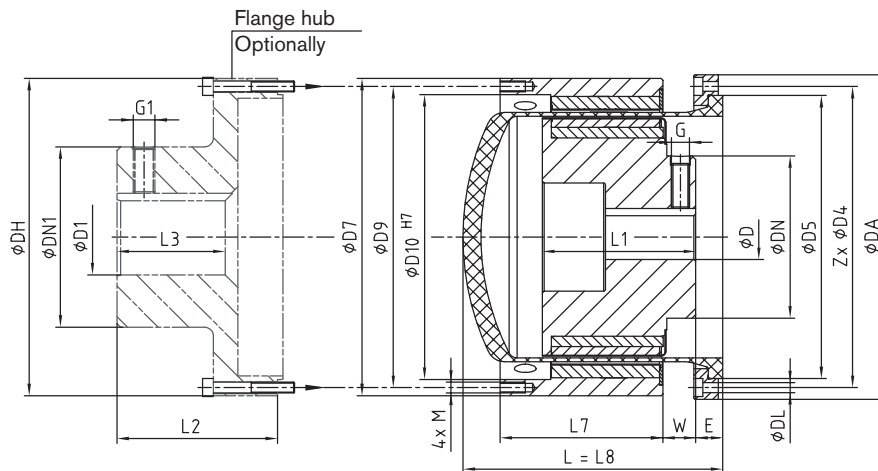

## Use in potentially explosive atmospheres

MINEX® couplings with containment shrouds made of carbon fibre reinforced PEEK are suitable for power transmission in drives in potentially explosive atmospheres. They are assessed and approved as components of category II according to EU directive 2014/34/EU and thus suitable for the use in potentially explosive atmospheres of zone 2G.

If the couplings operate in potentially explosive atmospheres, the user has to provide for special measures. Please read through our information included in the respective type examination certificate and the operating and assembly instructions at [www.ktr.com](http://www.ktr.com).



# MINEX®-S

## Magnetic couplings

### Containment shroud – material oxide ceramics

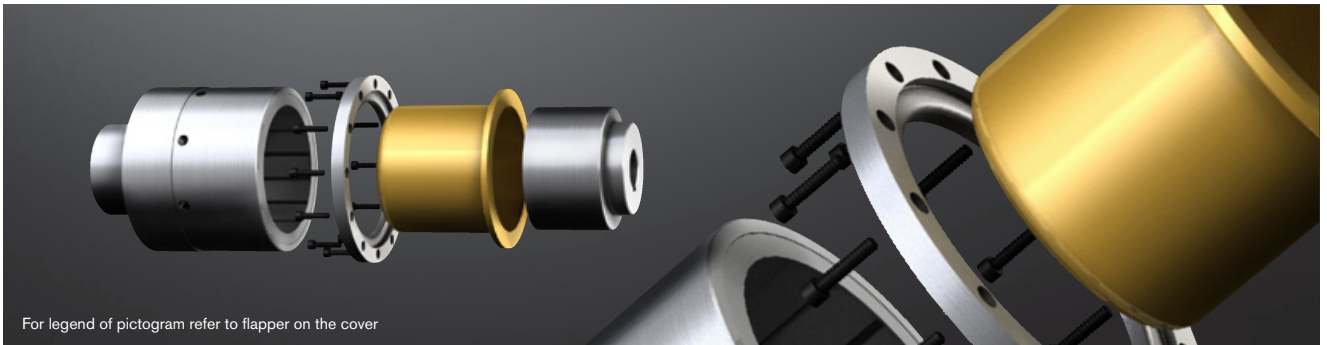

For legend of pictogram refer to flapper on the cover

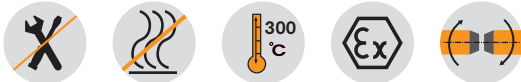

Technical data – Internal rotor and containment shroud														
Size	T <sub>K</sub> max [Nm] with 20 °C	Dimensions [mm]												
		Internal rotor						Containment shroud						
		Finish bore D <sup>1)</sup>		DN	L1	E		G	D5	D4	DA	DL	S	L = L <sub>B</sub> <sup>2)</sup>
min.	max.	min.	max.											
SB 60/8	14	12	22	36	56	1	21.0	M 5	75	82	99	5.5	6	92
SC 60/8	22	12	22	36	76	1	2.0	M 5	75	82	99	5.5	6	92
SB 75/10	24	12	32	45	58	17.5	37.5	M 6	89	100	118	9.0	8	108
SC 75/10	40	12	32	45	80	5	13.0	M 6	89	100	118	9.0	8	108
SD 75/10	70	12	32	45	90	5	5.0	M 6	89	100	118	9.0	8	108
SB 110/16	70	14	55	80	65	4	28.0	M 8	132	151	168	9.0	12	115
SC 110/16	100	14	55	80	85	4	9.0	M 8	132	151	168	9.0	12	115
SB 135/20	110	20	70	90	65	4	46.5	M 10	157	167	180	6.6	12	143
SC 135/20	155	20	70	90	85	4	26.5	M 10	157	167	180	6.6	12	143
SD 135/20	210	20	70	90	110	4	4.0	M 10	157	167	180	6.6	12	143
SC 165/24	220	24	80	110	85	4	28.0	M 12	196	210	228	9.0	12	150
SD 165/24	300	24	80	110	110	4	4.0	M 12	196	210	228	9.0	12	150
SE 165/24	390	24	80	110	130	4	17.0	M 12	196	210	228	9.0	12	185
SD 200/30	460	38	90	130	135	4	4.0	M 16	229	246	265	9.0	12	185
SE 200/30	600	38	90	130	135	4	4.0	M 16	229	246	265	9.0	12	185

Technical data – External rotor, flange hub and general														
Size	Dimensions [mm]													
	External rotor					Flange hub				General				
	D10	D9	D7	M	L7	Max. finish bore		DH	L2	L3	G1	W	Total length <sup>2)</sup>	
D1 <sup>1)</sup>						DN1	min.						max.	
SB 60/8	76	84	94	M 6	79.5	42	60.0	94	42	38	M 6	12.5	135	156
SC 60/8	76	84	94	M 6	79.5	42	60.0	94	42	38	M 6	12.5	135	135
SB 75/10	90	100	110	M 6	61.3	42	60.0	114	64.5	35.5	M 6	14.2	155.5	175.5
SC 75/10	90	100	110	M 6	83.9	42	60.0	114	64.5	35.5	M 6	14.2	167.5	175.5
SD 75/10	90	100	110	M 6	91	42	60.0	114	64.5	35.5	M 6	14.2	174.7	174.7
SB 110/16	130	138	150	M 6	61.3	55	85.0	153	87.5	45.5	M 10	18.7	171.5	195.5
SC 110/16	130	138	150	M 6	81.3	55	85.0	153	87.5	45.5	M 10	18.7	191.5	196.5
SB 135/20	158	167	176	M 6	70.3	70	100.0	176	89	67	M 12	18.2	215	224
SC 135/20	158	167	176	M 6	90.3	70	100.0	176	89	67	M 12	18.2	215	224
SD 135/20	158	167	176	M 6	110.3	70	100.0	176	89	67	M 12	20.7	220	220
SC 165/24	186	195	204	M 6	90.3	75	110.0	204	94	70	M 16	18.5	255	230.5
SD 165/24	186	195	204	M 6	110.3	75	110.0	204	94	70	M 16	20.7	229	229
SE 165/24	186	195	204	M 6	130.3	75	110.0	204	94	70	M 16	20.7	260	260
SD 200/30	220	230	240	M 6	130.3	90	120.0	240	120	88	M 16	25.7	280	280
SE 200/30	220	230	240	M 6	130.3	90	120.0	240	120	88	M 16	25.7	280	280

<sup>1)</sup> Bores H7 with keyway to DIN 6885 sheet 1 [JS9]

<sup>2)</sup> Total length without flange hub = L<sub>S</sub>

Technical data										
Size	T <sub>M</sub> max [Nm] with 20 °C	Internal rotor			Containment shroud			External rotor (+ flange hub optionally)		
		Standard material		Max. temperature t <sub>max.</sub> [°C]	Standard material		Max. pressure P <sub>N</sub> [bar]	Standard material		Max. temperature t <sub>max.</sub> [°C]
		Hub	Magnets		Clamping ring	Cont. shroud		Hub	Magnets	
SB 60/8	14	1.4571	Sm2Co17	300	Stainless steel	ZrO2MgO	40/60	S355J2	Sm2Co17	300
SC 60/8	22	1.4571	Sm2Co17	300	Stainless steel	ZrO2MgO	40/60	S355J2	Sm2Co17	300
SB 75/10	24	1.4571	Sm2Co17	300	Aluminium	ZrO2MgO	40/60	S355J2	Sm2Co17	300
SC 75/10	40	1.4571	Sm2Co17	300	Aluminium	ZrO2MgO	40/60	S355J2	Sm2Co17	300
SD 75/10	70	1.4571	Sm2Co17	300	Aluminium	ZrO2MgO	40/60	S355J2	Sm2Co17	300
SB 110/16	70	1.4571	Sm2Co17	300	Aluminium	ZrO2MgO	25/37.5	S355J2	Sm2Co17	300
SC 110/16	100	1.4571	Sm2Co17	300	Aluminium	ZrO2MgO	25/37.5	S355J2	Sm2Co17	300
SB 135/20	110	1.4571	Sm2Co17	300	Aluminium	ZrO2MgO	25/37.5	S355J2	Sm2Co17	300
SC 135/20	155	1.4571	Sm2Co17	300	Aluminium	ZrO2MgO	25/37.5	S355J2	Sm2Co17	300
SD 135/20	210	1.4571	Sm2Co17	300	Aluminium	ZrO2MgO	25/37.5	S355J2	Sm2Co17	300
SC 165/24	220	1.4571	Sm2Co17	300	Aluminium	ZrO2MgO	25/37.5	S355J2	Sm2Co17	300
SD 165/24	300	1.4571	Sm2Co17	300	Aluminium	ZrO2MgO	25/37.5	S355J2	Sm2Co17	300
SE 165/24	390	1.4571	Sm2Co17	300	Aluminium	ZrO2MgO	25/37.5	S355J2	Sm2Co17	300
SD 200/30	460	1.4571	Sm2Co17	300	Aluminium	ZrO2MgO	25/37.5	S355J2	Sm2Co17	300
SE 200/30	600	1.4571	Sm2Co17	300	Aluminium	ZrO2MgO	25/37.5	S355J2	Sm2Co17	300

Ordering example:	MINEX® SB 135/20	NdFeB	d <sub>i</sub> Ø20 mm	d <sub>a</sub> Ø24 mm	Oxide ceramics ZrO <sub>2</sub> MgO
	Coupling size	NdFeB – t <sub>max.</sub> = 150 °C Sm2Co17 – t <sub>max.</sub> = 300 °C	Finish bore (H7), feather keyway acc. to DIN 6885 sheet 1 (JS9)		Containment shroud type

## Examples of application

Like with the types with containment shroud made of PEEK, MINEX® couplings with containment shroud made of ceramics are an economic, energy-efficient alternative to the metallic types. Again they do not generate any eddy current losses and as a result do not generate any heat so that usually expensive cooling measures can be done without. Compared to PEEK, the containment shrouds made of ceramics are characterized by higher resistance to pressure and an excellent temperature resistance.

Typical applications: vacuum pumps, fan drives, compressors, agitators, PU foaming lines

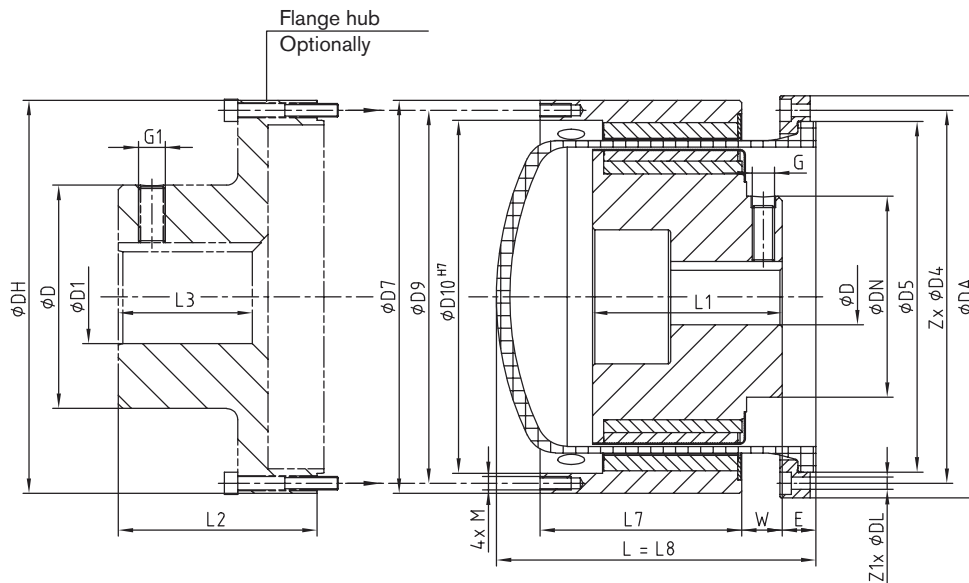

Optional flange hub with bore  $d_f$

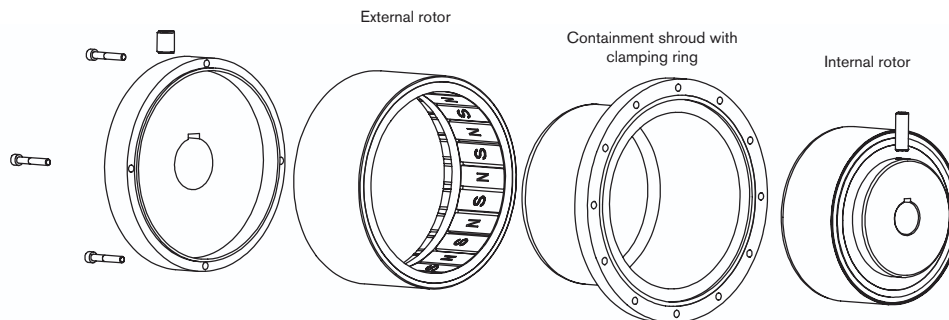

## Use in potentially explosive atmospheres

MINEX® couplings with containment shrouds made of oxide ceramics are suitable for power transmission in drives used in potentially explosive atmospheres. They are assessed and approved as components of category II according to EU directive 2014/34/EU and thus suitable for the use in potentially explosive atmospheres of zone 2G.

Please read through our information included in the respective type examination certificate and the operating and assembly instructions at [www.ktr.com](http://www.ktr.com).



# MINEX®-S Magnetic couplings

## Conversion kits and customised subassemblies

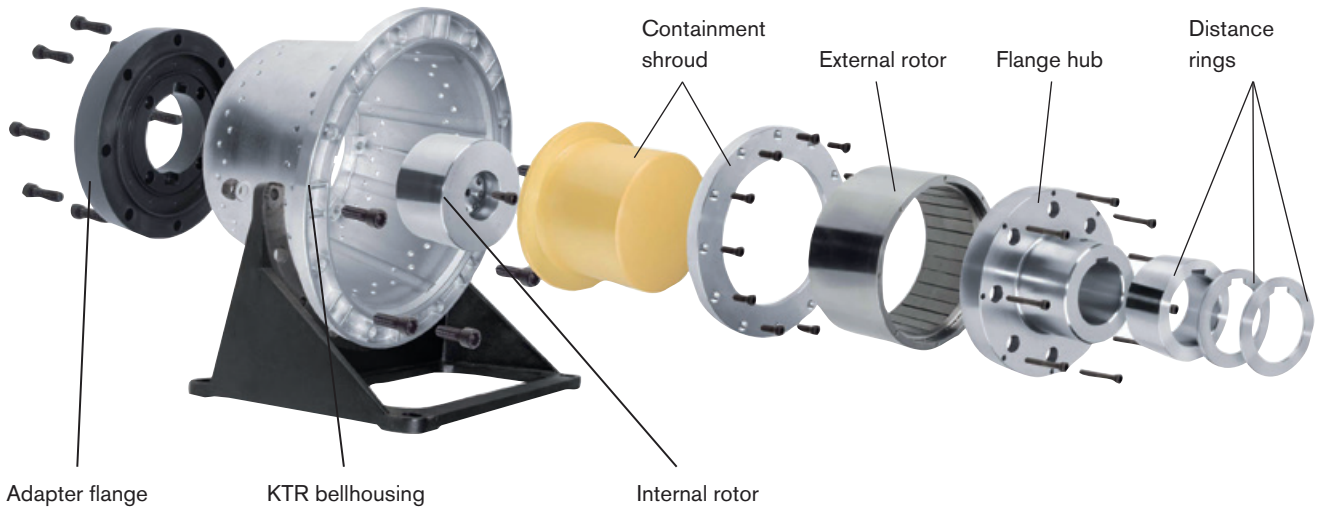

On request KTR provides customised special solutions in combination with KTR hydraulic components, allowing to easily retrofit existing systems with MINEX®-S.

### Conversion kits for PUR foaming processes

When conveying and proportioning the media polyol and isocyanate in the processing plants for PUR, ambient air has to be prevented from penetrating into the process, since otherwise adverse reactions may be generated.

For a reliable sealing of such drives KTR provides standard conversion kits, among others for axial piston pumps type REXROTH A2VK/A7VK and ROTARY POWER C series offering the following benefits:

- maintenance-free operation
- downtimes are considerably reduced
- no more problems with sealing
- better efficiency and process reliability

The subassemblies are available for all motor-pump-combinations and in various materials.



Maintenance-free sealing of proportioning pumps for polyol and isocyanate in high-pressure reaction moulding machines

Pump data		Motor data (4 poles, n=1500 rpm)			Coupling data		
Pump	Type	Motor	Power [kW]	Torque T <sub>N</sub>	Size	Max. torque T <sub>K max</sub>	Bellhousings
REXROTH A2VK/A7VK	A2/A7VK-12	132 S	5.5	35 Nm	SB 110/16	60 Nm	PL 300/13/...
		132 M	7.5	48 Nm	SC 110/16	95 Nm	
		160 M	11	70 Nm	SC 135/20	145 Nm	
	A2/A7VK-28	160 M	11	70 Nm	SC 135/20	145 Nm	PL 350/7/...
		160 L	15	96 Nm	SD 135/20	200 Nm	
		180 M	18.5	118 Nm	SD 135/20	200 Nm	
A2/A7VK-55	180 L	160 L	15	96 Nm	SC 165/24	210 Nm	PL 350/7/...
		180 M	18.5	118 Nm	SC 165/24	210 Nm	
	200 L	180 L	22	144 Nm	SD 165/24	280 Nm	PL350/7/...
		200 L	30	196 Nm	SE 165/24	280 Nm	PL400/5/...
		225 S/M	37/45	240/292 Nm	SE 165/24	370 Nm	PL450/3/...
A2/A7VK-107	225 S/M	37/45	240/292 Nm	SE 165/24	370 Nm	PL400/5/...	
ROTARY POWER C-Range	C 01	100L	2.2	14 Nm	SB 75/10	24 Nm	PK 250/13/...
	C 04	132 M	7.5	48 Nm	SC 110/16	95 Nm	PL300/13/...
		132 S	5.5	35 Nm	SB 110/16	60 Nm	PL300/13/...
	C 07	132 M	7.5	48 Nm	SC 110/16	95 Nm	PL300/13/...
		160 L	15	96 Nm	SD 135/20	200 Nm	PL 350/7/...
C20	180 M	18.5	118 Nm	SD 135/20	200 Nm	PL 350/7/...	

**Other types**

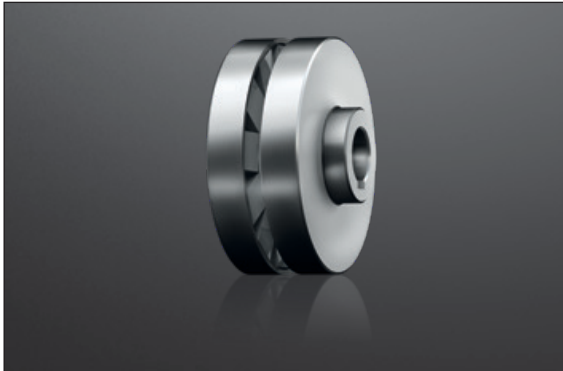

**Disk coupling**

With this type the magnets are arranged opposite each other in axial direction. Thus this type is able to transmit the torque through plane walls.

Furthermore it provides the following benefits:

- compact
- drive of applications in closed liquid containers
- torque setting via air gap

**Applications:** Pumps, agitators, compressors, fans, swivel drives

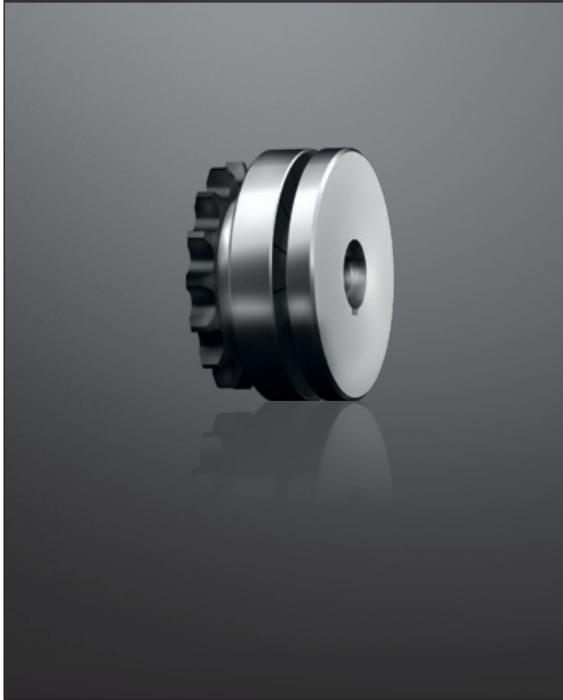

**Hysteresis coupling MINEX®-H**

Different from the MINEX®-S magnetic coupling this type switches to slipping operation once the maximum transmittable torque has been achieved, while it continues to transmit  $T_{max}$  as a holding torque.

- wear-free torque limitation
- maintenance-free & load-holding
- very good repeatability of torque
- applicable as a coupling or brake

**Applications:** roller conveyors, winder drives, capping machines, etc.

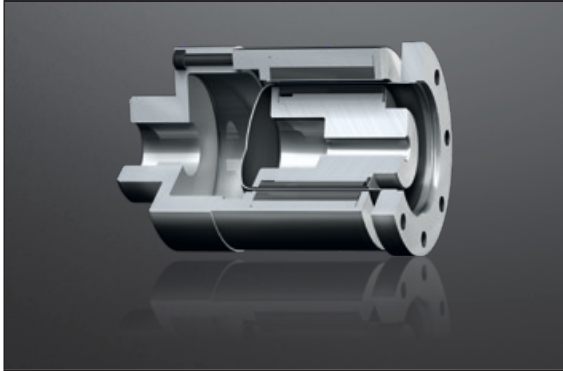
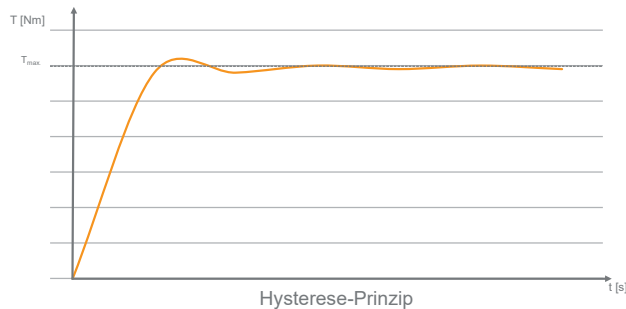

**MINEX®-S fully made of stainless steel**

If requested, KTR supplies MINEX®-S fully made of stainless steel. The magnets of the external rotor are encapsulated just like with the internal rotor.

**Applications:** offshore, marine, etc.



**customised special solutions**

If requested, KTR supplies MINEX®-S in combination with the plain bearing required for the driven shaft.

# MINEX®-H

## Magnetic couplings

### Hysteresis coupling

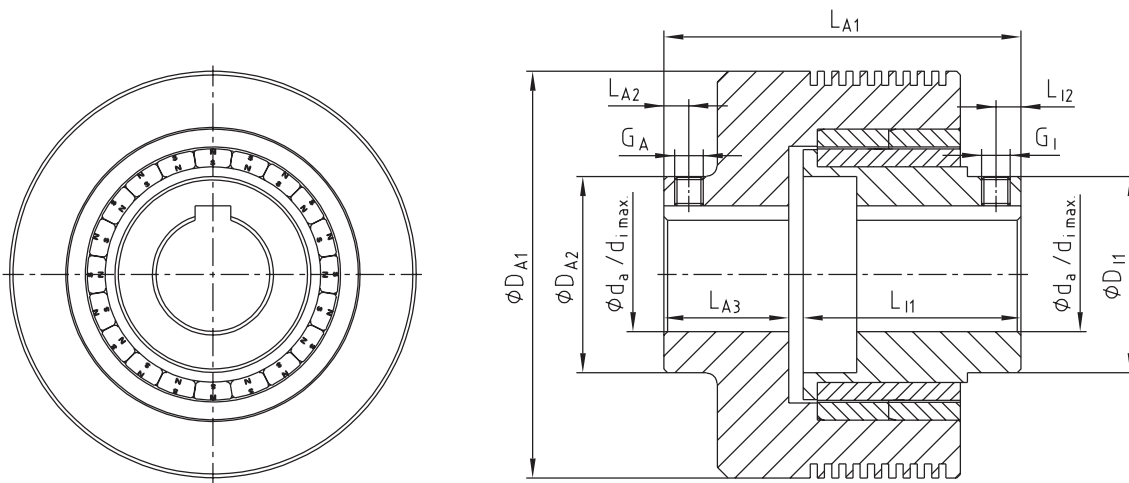
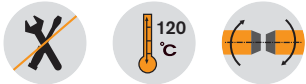
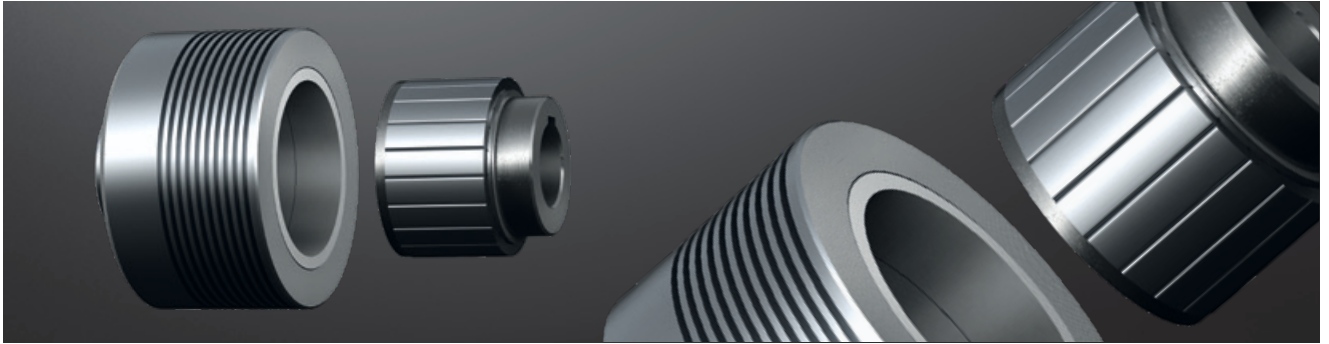

Technical data															
Size	Overload torque T <sub>max. 20 °C</sub> [Nm]	Finish bore d <sub>a</sub> /d <sub>i</sub> max. [mm]	Dimensions [mm]										permissible power loss P <sub>V</sub> perm. 20 °C [W]	Max. speed n <sub>max.</sub> [rpm]	Max. temperature t <sub>max.</sub> [°C]
			DA1	DA2	LA1	LA2	LA3	D <sub>I1</sub>	L <sub>I1</sub>	L <sub>I2</sub>	G <sub>A</sub>	G <sub>I</sub>			
HA 48/12	1.2	16	82	35	80	7	35	35	41	7	M 4	M 4	80	1800	120
HB 48/12	2.4	16	82	35	100	7	35	35	61	7	M 4	M 4	88	1800	120
HA 60/16	2	22	94	45	80	7	35	45	41	7	M 5	M 5	87	1800	120
HB 60/16	4	22	94	45	100	7	35	45	61	7	M 5	M 5	96	1800	120
HA 71/20	3	32	114	55	80	7	35	55	41	7	M 8	M 8	98	1800	120
HB 71/20	6	32	114	55	100	7	35	55	61	7	M 8	M 8	110	1800	120

### Technical selection:

$$P_V = \frac{T_{\text{max. 20 °C}} \cdot n_{\text{Slip}}}{9.55} \quad * Z \leq P_V \text{ perm. } 20 \text{ °C}$$

$$Z = \frac{t_{\text{Slip}}}{t_{\text{Cycle}}}$$

P<sub>V</sub> = Power loss [W]  
 T<sub>max. 20 °C</sub> = Transmittable torque [Nm]  
 P<sub>V all. 20 °C</sub> = Permissible power loss [W]  
 n<sub>Slip</sub> = Slip speed [1/min]  
 Z = Cycle factor (continuous slip operation Z=1)  
 t<sub>Slip</sub> = Slip time [s]  
 t<sub>Cycle</sub> = Cycle time [s]

Ordering example:	MINEX® HB 60/16	d <sub>i</sub> Ø18 mm	d <sub>a</sub> Ø20 mm
	Coupling size	Finish bore (H7), feather keyway acc. to DIN 6885 sheet 1 (JS9)	

## Torque curve with overload

The MINEX®-H transmits the torque contactlessly by means of magnetic forces and serves as a wear-free torque limiter in case of overload.

### Function standard mode:

The torque is transmitted from the drive to the output element contactlessly by means of magnetic forces. The speed is synchronously transmitted as long as the operating torque is below the selection torque (slip torque).

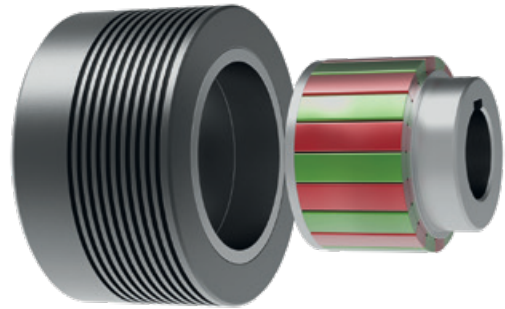

MINEX®-S

### Function overload mode:

As soon as the operating torque exceeds the selection torque, the coupling slips and a relative speed sets in between the drive and output side. At this moment the polarity of the hysteresis material is continuously reversed and it heats up. The selection torque is almost constant in case of an overload. As the relative speed increases, the slip torque increases due to the eddy current effect.

## Torque curve with overload

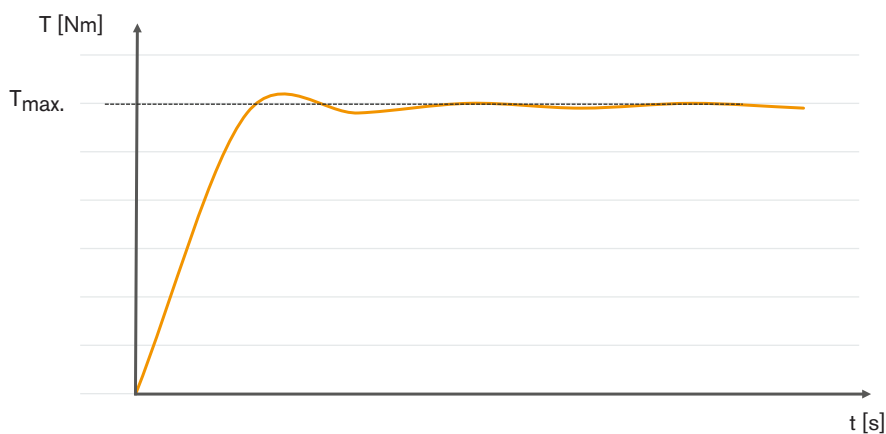

### Characteristics:

- Contactless torque transmission by means of magnetic forces
- Wear-free torque limitation
- Maintenance-free
- Load-holding
- Very good repeatability of torque
- Applicable as a coupling or brake

### Examples of application:



Filling systems



Film winder



Materials handling



Medical technology



Unwinding and winding equipment



# Torque limiters

Types and operating description	256
Selection of torque limiters	257

## RUFLEX®

Design and operation	258
Standard	259
With sprocket	260
Max. type	261
With torsionally flexible ROTEX®	262
With torsionally stiff BoWex®	263

## SYNTEX®

Design and operation	276
Operating principles	277
Flange type	278
With sprocket	280
With toothed belt pulley	282
With backlash-free ROTEX® GS	283

## KTR-SI

Design and operation	264
Operating principles	267
KTR-SI flange type	268
KTR-SI with torsionally flexible ROTEX®	269
KTR-SI FRE flange type	270
KTR-SI FRE with torsionally flexible ROTEX®	271
KTR-SI FRE customised type	272
KTR-SI FRA flange type FT	274
KTR-SI FRA with torsionally flexible ROTEX®	275

## SYNTEX®-NC / KTR-SI Compact

Design and operation	284
Operating principle	285

## SYNTEX®-NC

Hub type	286
With backlash-free ROTEX® GS	287
With torsionally stiff TOOLFLEX® S	288

## KTR-SI Compact

Flange type	289
With backlash-free ROTEX® GS	290

RUFLEX®



KTR-SI



KTR-SI FRA



SYNTEX®



SYNTEX®-NC

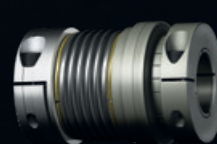

KTR-SI Compact



# TORQUE LIMITERS

## TYPES AND OPERATING DESCRIPTION

### Properties of torque limiters

							
Product	RUFLEX®	KTR-SI	KTR-SI FRE	KTR-SI FRA	SYNTEX®	SYNTEX®-NC	KTR-SI Compact
Type	Torque limiter	Overload system	Overload system	Overload system	Backlash-free overload system		
<b>Torque limitation</b>							
Friction (load-retaining)	●						
Ratchet coupling		●	●	●	●	●	●
Synchronous ratcheting SK/SR (load-separating)		●			●	●	●
Ratcheting DK (load-separating)		●			●	●	●
Idle rotation FR/FRE/FRA (load-separating)		●	●	●			
Fail-safe SGR (no mechanical separation)		●					
<b>Properties</b>							
Backlash-free					●	●	●
High repeatability		●	●	●	●	●	●
Quick separation with overload						●	●
Signal by limit switch/sensor		●	●	●	●	●	●
Torque setting possible when in place	●	●	●	●	●	●	●
<b>Torque range <math>T_{KN}</math> [Nm]</b>							
min. - max.	0.5 - 12,000	2.5 - 8,200	1,000 - 60,000 (and above)	5 - 3,000	6 - 400	2 - 550	3 - 3,100
<b>Max. bore [mm]</b>							
	140	100	200 (and above)	80	50	60	80
<b>Shaft-hub-connection</b>							
Positive locking	●	●	●	●	●	●	●
Frictionally engaged			●		●	●	●
<b>Speed <math>n_{max}</math> [rpm]</b>							
	10,000	6,000	3,300	3,600	1,500	3,500	4,000
<b>Special features</b>							
	high power density, low price	hardened surfaces, solid design	modular design, for high torques	re-engagement by reversing the direction of rotation	for tailor-made solutions, low cost, ideally suitable for bigger quantities	high power density, light-weight design	hardened surfaces, solid design
<b>Applications</b>							
	slowly rotating drives such as sprocket or V-belt belt drives, conveyors, rotary feeders, ...	rugged drive situations, e. g. crushers, ...	shredders, extruders, steel mills, test benches	shredders, extruders, materials handling, ...	customised design, packaging machines, linear drives, ...	dynamic drives, packaging machines, machine tools, linear drives, ...	packaging machines, special purpose machines, materials handling, ...

● ≈ Standard

# TORQUE LIMITERS

## TYPES AND OPERATING DESCRIPTION

### Product finder of torque limiters

Product	RUFLEX®	KTR-SI	KTR-SI FRE	KTR-SI FRA	SYNTEX®	SYNTEX®-NC	KTR-SI Compact
Type	Torque limiter	Overload system	Overload system	Overload system	Backlash-free overload system		
<b>Types (extract)</b>							
Combined with:							
» Sprocket/toothed belt pulley/flange	●	●	●	●	●	●	●
» ROTEX® torsionally flexible jaw coupling	●	●	●	●			
» BoWex® torsionally stiff curved-tooth gear coupling®	●						
» TOOLFLEX® torsionally stiff metal bellow-type coupling						●	
» ROTEX® GS backlash-free jaw coupling					●	●	●
» RADEX®-N torsionally stiff steel laminae coupling	○	○	○				
» RADEX®-NC torsionally stiff servo laminae coupling						○	
» GEARex® all-steel gear coupling			○				
Integrated ball bearing			●			●	●

● ≈ Standard  
○ ≈ On request

### Information on selection of torque limiters

A torque limiter is a mechanical component used in machines and drive trains to prevent overload or a blocking torque. To make sure that process-related torque peaks do not yet cause the torque limiter to release, the release torque should at least be 30 % above the maximum operating torque (see diagramme). Torque limiters and positive-locking, ratcheting overload systems should be used with reduced operating speed only after having applied higher release torques.

Frequent or continuous slipping or ratcheting increases the wear on the torque limiter. After the torque limiter separated driving from driven side in case of overload, it may take some time before the drive stops due to large masses in the drive train. This may generate higher wear on the torque limiters and the overload system re-engaging automatically. That is why we recommend to use the load-separating overload system KTR-SI as an idle rotation type FR/FRE/FRA (page 273 et seqq.) for drives with larger inertias or higher operating speeds.

For applications with alternating torques for which it is important to prevent unwanted motions or backlash between the coupling components, we recommend to use the backlash-free overload systems such as KTR-SI Compact or SYNTEX®-NC (e. g. in CNC machines or servo drives). Safety couplings should basically be monitored electrically, by an additional limit switch or sensor, to switch off the drive directly in case of overload. For combinations with torsionally flexible couplings such as ROTEX® or ROTEX® GS as well as torsionally stiff couplings such as RADEX®-NC or TOOLFLEX®, the respective advice regarding selection and the respective operating and assembly instructions must be observed.

We will be pleased to assist you with any technical questions about the selection of torque limiters. For that purpose we dispose of state-of-the-art simulation and calculation programs. Here the principle applies: The more detailed the data provided, the more accurate the calculation results. Unless otherwise specified, our feather keyways are designed acc. to DIN 6885 sheet 1 [JS9]. The shaft-hub-connection needs to be verified by the customer. A smooth operation is only ensured if the overload torque set exceeds the maximum operating torque of the machine (see diagramme).

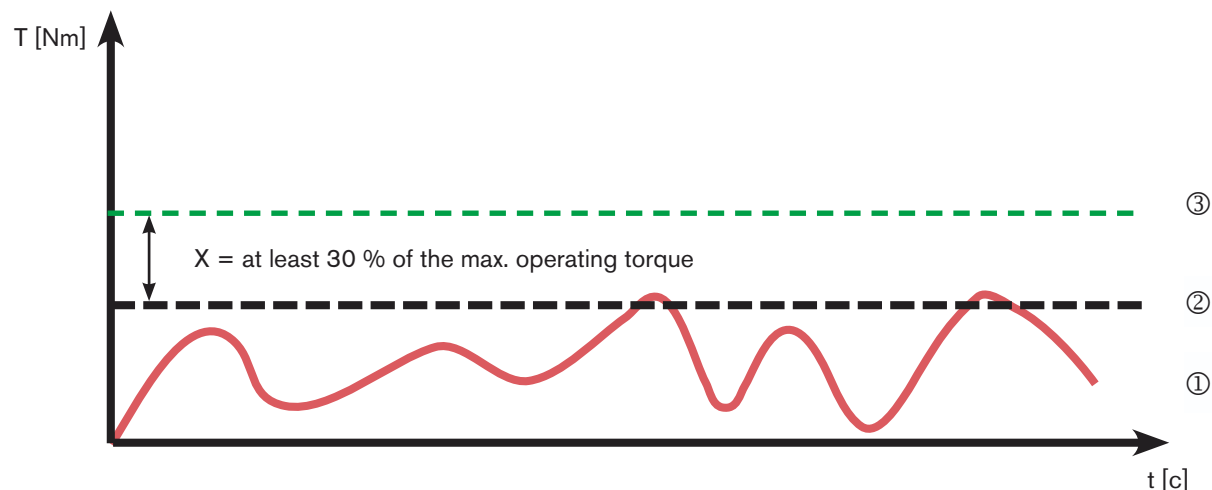

- ① Torque curve of the machine
- ② Max. operating torque arising on the machine
- ③ Torque set on the coupling

# RUFLEX®

## Torque limiters

### Design and operation

- Load-retaining overload protection up to 12,000 Nm (standard)
- Available with various drive components (e. g. sprocket) and combinations (e. g. ROTEX®)
- Asbestos-free and rust-proof friction lining for dry running
- High wear capacity, long service life
- High-quality plain bush with dry lubricant
- Torque setting possible when in place



- Protection of the nut by locking in 12 different positions
- Easy assembly and torque setting
- Coupling components made of steel, large safety reserves
- Corrosion protection by zinc-coated and passivated surfaces
- Rust-proof and acid-proof type on request
- High power density due to high-quality disk springs and friction linings

The RUFLEX® modular system provides solutions for your drive, too.

The combination with the proven KTR couplings and the integration of customised drive components (e. g. sprockets) allows for an overload protection optimally adapted to the respective application.

Various disk spring layerings and high-quality friction linings ensure high power density even with only small mounting space.

RUFLEX® consists of the following components:

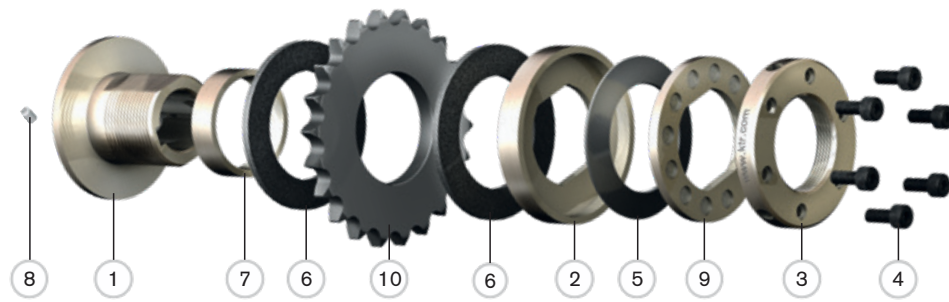

List of components:

- |                         |                                    |
|-------------------------|------------------------------------|
| ① Hub                   | ⑥ Friction lining                  |
| ② Pressure ring         | ⑦ Plain bush                       |
| ③ Setting nut           | ⑧ Setscrew                         |
| ④ Torque setting screws | ⑨ Lock washer                      |
| ⑤ Disk spring           | ⑩ Drive component (e. g. sprocket) |

### Disk spring layerings:



- 1TF**
- Small specific load on friction linings
  - For small to medium torques
  - Long service life of friction linings



- 1TFD**
- Small specific load on friction linings
  - Torques like with type 1TF
  - Only small decrease of torque even with a longer period of friction
  - Precision torque adjustment due to double spring excursion



- 2TF**
- Standard specific load of friction linings
  - Medium wear and decrease of torque with longer slipping periods
  - Double torque due to double disk spring layering



- 2TFD**
- Standard specific load of friction linings
  - Torques like with type 2TF
  - Only small decrease of torque even with a longer period of friction
  - Precision torque adjustment due to double spring excursion



- 3TF**
- High specific load on friction linings
  - High wear and decrease of torque with longer slipping periods
  - Applicable only in special cases for designs with only limited dimensions

## Standard width of drive component

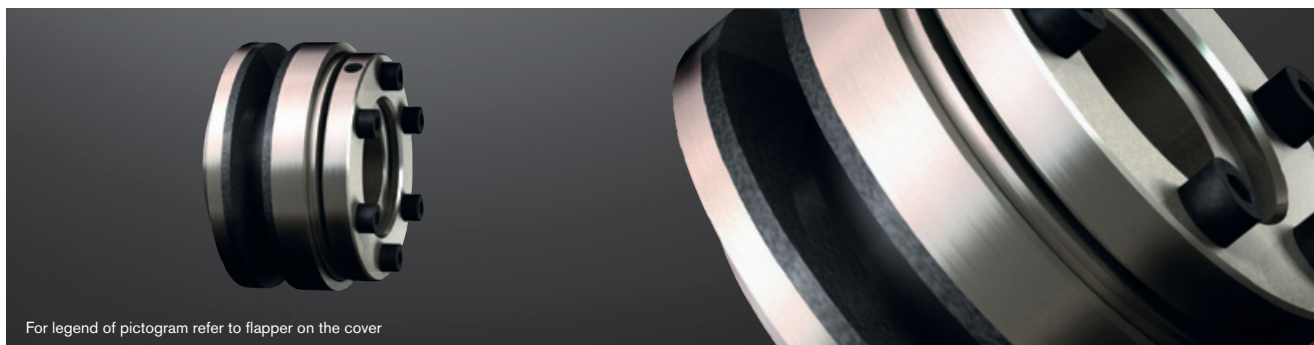

For legend of pictogram refer to flapper on the cover

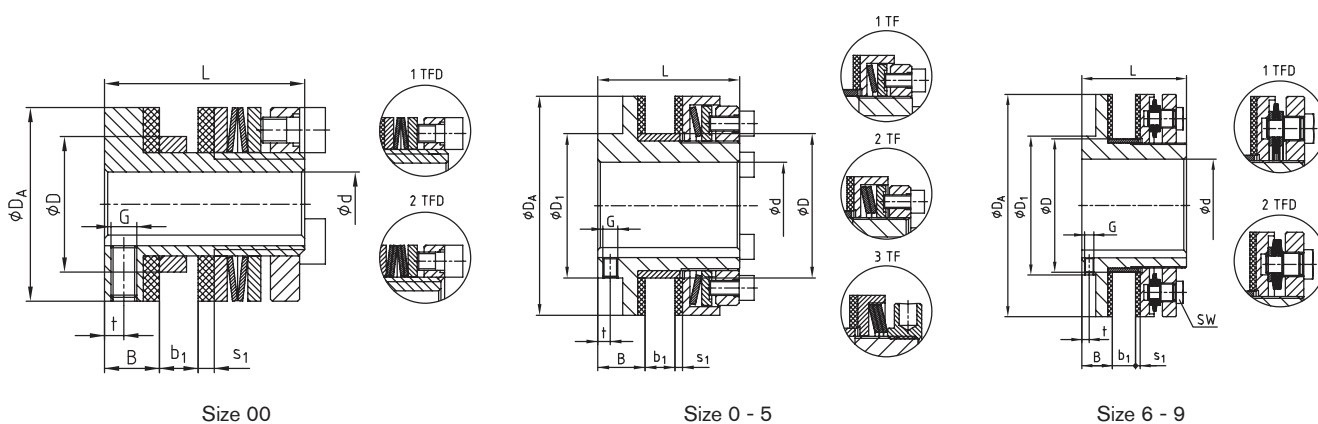

### Technical data – dimensions

Size	Max. speed <sup>4)</sup> [rpm]	Torques [Nm]			Dimensions [mm]												
					Bore d		D <sup>2)</sup>	D <sub>1</sub>	D <sub>A</sub>	B	Drive component b <sub>1</sub>		s <sub>1</sub>	L	Setscrew		
					Pilot bore	max.					min.	max.			t	G	
00	10000	(0.5) <sup>5)</sup> 1-3	2-5	–	–	10	21	–	30	8.5	2	6	2.5	31	3	M4	
0	8500	2-10	4-20	–	–	19 (20) <sup>1)</sup>	35	45	45	45	8.5	2	6	2.5	33	3	M4
01	6600	5-35	10-70	–	–	22	40	40	58	16	3	8	3	45	4	M5	
1	5600	20-75	40-150	130-200	–	25	44	45	68	17	3	10	3	52	5	M5	
2	4300	25-140	50-280	250-400	–	35	58	58	88	19	4	12	3	57	5	M6	
3	3300	50-300	100-600	550-800	–	45	72	75	115	21	5	15	4	68	5	M6	
4	2700	90-600	180-1200	1100-1600	–	55	85	90	140	23	6	18	4	78	5	M8	
5	2200	400-800	800-1600	1400-2100	–	65	98	102	170	29	8	20	5	92	8	M8	
6	1900	300-1200	600-2400	–	38	80	116	120	200	31	8	23	5	102	8	M8	
7	1600	600-2200	1200-4400	–	45	100	144	150	240	33	8	25	5	113	8	M10	
8	1300	900-3400	1800-6800	–	58	120	170	180	285	35	8	25	5	115	8	M10	
9	1000	2500-6000	6000-12000	–	65	140	237	225	350	53	16	28	6	162	11	M12	

<sup>1)</sup> The figure in brackets specifies the max. bore with keyway to DIN 6885 sheet 3 (low-rise design)

<sup>2)</sup> Bore tolerance (drive component): F8 with size 00 - 4, H8 with size 5 - 9

<sup>3)</sup> 3 disk springs (3TF), for low friction work only

<sup>4)</sup> See comments on page 265

<sup>5)</sup> With special disk spring

On request:



- With clamping setting nut for size 1 - 5 (standard with 3TF)
- For radial torque setting

- With taper sleeve (hub type 4.5)
- Frictionally engaged shaft-hub-connection

Ordering example:	RUFLEX® 1	2TF	b <sub>1</sub> 10	d Ø20
Type/size		Disk spring layering	Width of drive component b <sub>1</sub>	Finish bore

# RUFLEX® Torque limiters

## With sprocket



For legend of pictogram refer to flapper on the cover

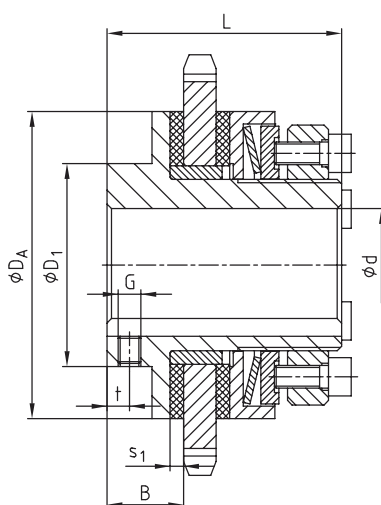

### Technical data – dimensions

Size <sup>4)</sup>	Max. speed <sup>3)</sup> [rpm]	Torques [Nm]			Dimensions [mm]								
					Max. bore		D <sub>1</sub>	D <sub>A</sub>	B	s <sub>1</sub>	L	Setscrew	
		1TF	2TF	3TF <sup>1)</sup>	d	t						G	
0	8500	2-10	4-20	-	19 (20) <sup>5)</sup>	45	45	8.5	3	33	3	M4	06 B-1 ( <sup>2</sup> / <sub>8</sub> x <sup>7</sup> / <sub>32</sub> ) z = 19
01	6600	5-35	10-70	-	22	40	58	16	3	45	4	M5	06 B-1 ( <sup>2</sup> / <sub>8</sub> x <sup>7</sup> / <sub>32</sub> ) z = 23
1	5600	20-75	40-150	130-200	25	45	68	17	3	52	5	M5	08 B-1 ( <sup>1</sup> / <sub>2</sub> x <sup>5</sup> / <sub>16</sub> ) z = 22
2	4300	25-140	50-280	250-400	35	58	88	19	3	57	5	M6	08 B-1 ( <sup>1</sup> / <sub>2</sub> x <sup>5</sup> / <sub>16</sub> ) z = 27
3	3300	50-300	100-600	550-800	45	75	115	21	4	68	5	M6	12 B-1 ( <sup>3</sup> / <sub>4</sub> x <sup>7</sup> / <sub>16</sub> ) z = 22
4	2700	90-600	180-1200	1100-1600	55	90	140	23	4	78	5	M8	16 B-1 (1 x 17.02) z = 21
5	2200	400-800	800-1600	1400-2100	65	102	170	29	5	92	8	M8	16 B-1 (1 x 17.02) z = 25

<sup>1)</sup> 3 disk springs, for low friction work only, with clamping setting nut

<sup>2)</sup> Review minimum number of teeth required / Other sprockets available on request.

<sup>3)</sup> See comments on page 265

<sup>4)</sup> Other sizes on request

<sup>5)</sup> The figure in brackets specifies the max. bore with keyway to DIN 6885 sheet 3 (low-rise design)

### Special type:

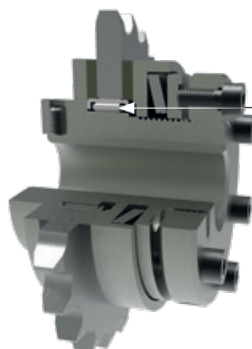

- If requested, available with needle bearing instead of plain bush
- For high radial loads on the sprocket
- With high speeds or long slipping periods

### Ordering example:

RUFLEX® 1	2TF	d Ø20	08 B -1 ( <sup>1</sup> / <sub>2</sub> x <sup>5</sup> / <sub>16</sub> ), z = 29	100 Nm
Type/size	Disk spring layering	Finish bore	Sprocket	Torque set

# RUFLEX® Torque limiters

## Max. type

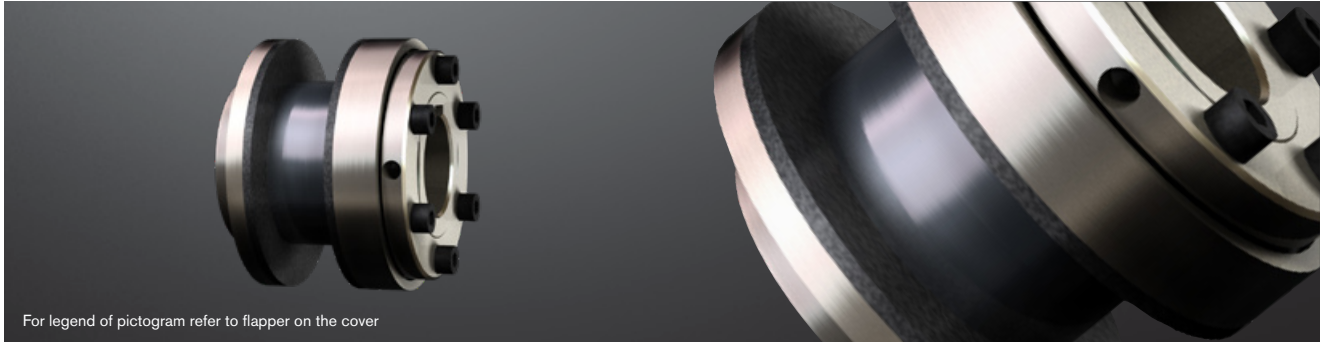

For legend of pictogram refer to flapper on the cover

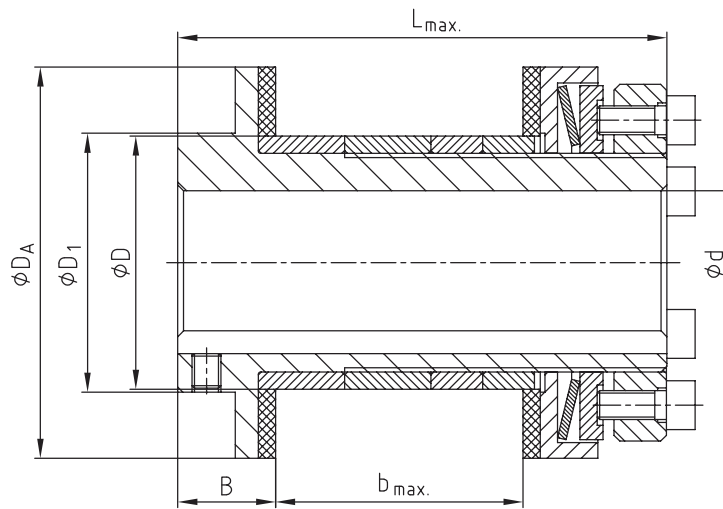

### Technical data – dimensions

Size	Max. speed <sup>3)</sup> [rpm]	Torques [Nm]			Dimensions [mm]						
		1TF	2TF	3TF <sup>2)</sup>	Max. bore d	D <sub>1</sub>	D <sub>A</sub>	B	Max. b	D <sup>1)</sup>	Max. L
01	6600	5-35	10-70	–	22	40	58	16	33	40	70
1	5600	20-75	40-150	130-200	25	45	68	17	43	44	85
2	4300	25-140	50-280	250-400	35	58	88	19	54	58	100
3	3300	50-300	100-600	550-800	45	75	115	21	62	72	115
4	2700	90-600	180-1200	1100-1600	55	90	140	23	91.5	85	154

<sup>1)</sup> Bore tolerance (drive component): F8

<sup>2)</sup> 3 disk springs, for low friction work only, with clamping setting nut

<sup>3)</sup> See comments on page 265



### Example:

- RUFLEX® max. with sprocket assembled
- Available as a complete subassembly with preset torque

### Ordering example:

RUFLEX® max. 1	2TF	b 35	d Ø20
Type/size	Disk spring layering	Width of drive component b	Finish bore

# RUFLEX® Torque limiters

With torsionally flexible ROTEX®



For legend of pictogram refer to flapper on the cover

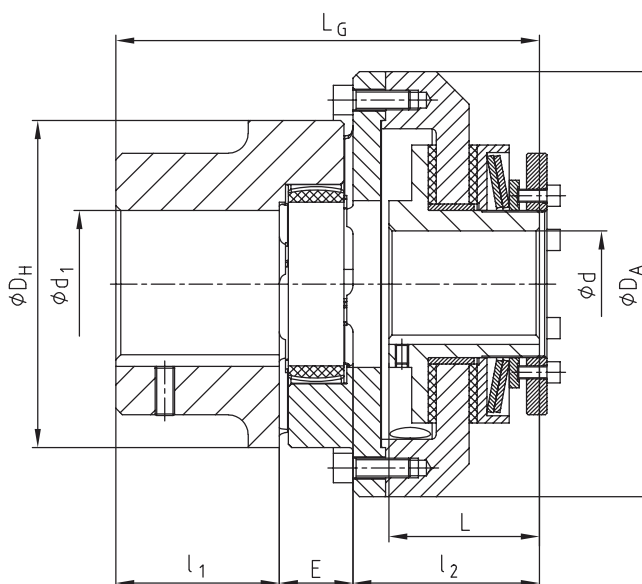

## Technical data – dimensions

RUFLEX® size	ROTEX® size	RUFLEX® Torques [Nm]			ROTEX® <sup>3)</sup> Torques [Nm]		Dimensions [mm]									
					98 Shore A		Bore d		DH	D <sub>A</sub>	l <sub>1</sub>	l <sub>2</sub>	E	L	L <sub>G</sub>	
		1TF	2TF	3TF <sup>2)</sup>	T <sub>KN</sub>	T <sub>K max</sub>	Pilot bore	max.								d <sub>1</sub>
00	14	(0.5) <sup>1)</sup> 1-3	2-5	–	12.5	25	–	10	16	30	44	11	35	13	31	59.5
0	19	2-10	4-20	–	17	34	–	19 (20) <sup>1)</sup>	25	40	63	25	37	16	33	78
01	24	5-35	10-70	–	60	120	–	22	35	55	80	30	50	18	45	98
1	28	20-75	40-150	130-200	160	320	–	25	40	65	98	35	58	20	52	113
2	38	25-140	50-280	250-400	325	650	–	35	48	80	120	45	64	24	57	133
3	48	50-300	100-600	550-800	525	1050	–	45	62	105	162	56	82	28	68	166
4	75	90-600	180-1200	1100-1600	1920	3840	–	55	95	160	185	85	80	40	78	205
5	90	400-800	800-1600	1400-2100	3600	7200	–	65	110	200	260	100	114	45	92	259
6	100	300-1200	600-2400	–	4950	9900	38	80	115	225	285	110	130	50	102	290
7	110	600-2200	1200-4400	–	7200	14400	45	100	125	255	330	120	142	55	113	317
8	140	900-3400	1800-6800	–	12800	25600	58	120	160	320	410	155	152	65	115	372
9	160	2500-6000	6000-12000	–	19200	38400	65	140	185	370	460	175	199	75	161	449

<sup>1)</sup> The figure in brackets specifies the max. bore with keyway to DIN 6885 sheet 3 (low-rise design)

<sup>2)</sup> 3 disk springs, for low friction work only, with clamping setting nut

<sup>3)</sup> See selection of ROTEX® couplings on page 14 et seqq.

<sup>4)</sup> With special disk spring

Ordering example:

RUFLEX® 1	2TF	d Ø20	ROTEX® 28	98 ShA	d <sub>1</sub> Ø25	100 Nm
Type/size	Disk spring layering	RUFLEX® bore	Type/size	Spider	ROTEX® bore	Torque set

# RUFLEX® Torque limiters

With torsionally stiff BoWex®



For legend of pictogram refer to flapper on the cover

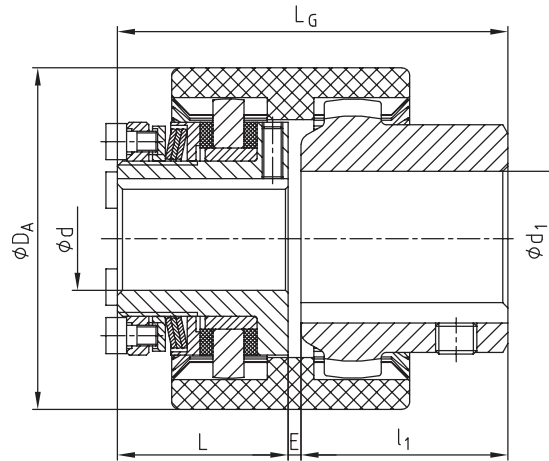

Technical data – dimensions													
RUFLEX® size	BoWex® size	RUFLEX® Torques [Nm]			BoWex® <sup>3)</sup> Torques [Nm]		Dimensions [mm]						
		1TF	2TF	3TF <sup>2)</sup>	TKN	TK max	Max. bore		DA	l1	L	E	LG
							d	d <sub>1</sub>					
00	19	(0.5) <sup>4)</sup> 1-3	2-5	–	16	32	10	19	48	25.0	31	2.5	58.5
0	28	2-10	4-20	–	45	90	19 (20) <sup>1)</sup>	28	66	40.0	33	2.5	75.5
01	38	5-35	10-70	–	80	160	22	38	83	35.5	45	1.0	81.5
1	48	20-75	40-150	130-200	140	280	25	48	95	45.5	52	1.0	98.5
2	65	25-140	50-280	250-400	380	760	35	65	132	64.0	57	1.0	122

<sup>1)</sup> The figure in brackets specifies the max. bore with keyway to DIN 6885 sheet 3 (low-rise design)

<sup>2)</sup> With clamping setting nut to be used on types limited in dimensions only

<sup>3)</sup> See selection of BoWex® couplings on page 14 et seqq.

<sup>4)</sup> With special disk spring

Ordering example:	RUFLEX® 1	1TF	d Ø20	BoWex® 48	d <sub>1</sub> Ø25	50 Nm
	Type/size	Disk spring layering	RUFLEX® bore	Type/size	BoWex® bore	Torque set

# KTR-SI

## Overload systems

### Design and operation

- Overload protection up to 8,200 Nm
- Available as a ratchet, synchronous, idle rotation and fail-safe design with the same dimensions
- Reduction of torque peaks
- High response accuracy, even after a long operating period
- Disconnection of the drive with overload by retrieving limit switch
- Automatically operative (DK, SR, SGR)

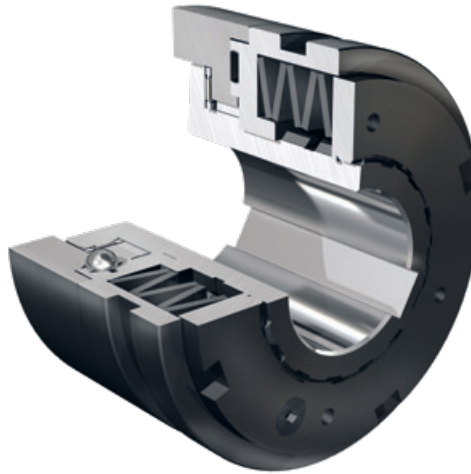

- Available in various types (e. g. with needle bearing) and combinations (e. g. with torsionally flexible ROTEX®)
- Easy assembly and torque setting
- Maintenance-free
- Insensitive to oil and grease
- Long service life due to high-quality materials

In case of overload the ratchet components (balls resp. rollers) leave their indentations, and a relative motion between the driving and driven side is generated. Damages caused by overload are reliably prevented in this way. The shift ring (3) makes an axial motion to the engagement travel „H“ activating the limit switch or proximity initiator. The signal can be used for controlling or disconnecting the drive. For restarting we would recommend to electrically bypass the limit switch or proximity switch for a short time.

#### Com- Description ponent

- 1 Hub
- 2 Flange ring
- 3 Shifting ring
- 4 Setting nut
- 5 Disk spring
- 6 Ball bearing cage
- 7 Plain bush
- 8 Axial disk
- 9 Axial needle bearing
- 10 Setscrew
- 11 Lock washer

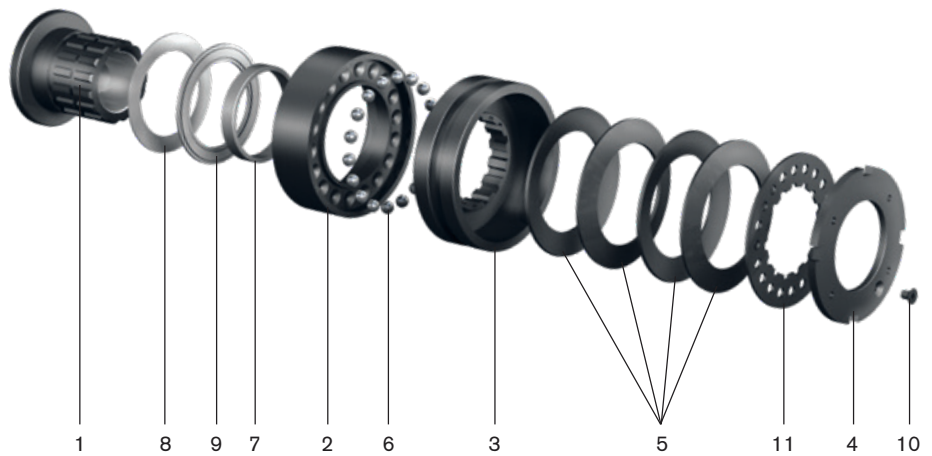

#### No signal with normal operation



Engaged



Limit switch

#### Signal with overload

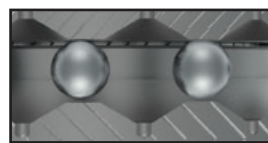

Disengaged



Limit switch

# KTR-SI FRE

## Idle rotation overload system

### Design and operation

- Setting range up to 60,000 Nm (higher torques available on request)
- Idle rotation overload system (load-separating)
- High repeatability

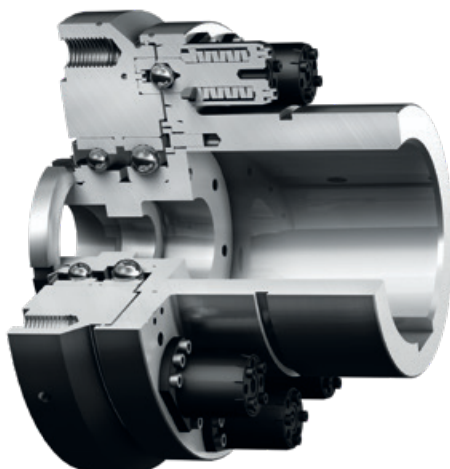

- flange type to connect toothed belt pulleys or sprockets
- Combination with ROTEX®, GEARex® or RADEX®-N as a shaft-to-shaft connection
- The intelligent further development of shear pin couplings and hydraulic clamping sets

The core of the overload system is formed by the idle rotation elements. They uncouple the driving and driven side in case of overload while protecting the drive train from damages. After eliminating the overload, the idle rotation segments are manually re-engaged so that the drive is released again. In order to set the coupling to the requested release torque, a defined pre-stress is generated on the disk springs in each idle rotation element via the setting nut. The number of idle rotation elements varies depending on the required release torque. If requested, the coupling can be preset by the manufacturer. It is also possible to individually adapt the coupling when in place.

#### Component Description

- 1 Hub
- 2 Bearing flange
- 3 Cap screw
- 4 Angular ball bearing
- 5 O-ring
- 6 KTR-SI FRE connection flange
- 7 Groove ball bearing
- 8 NILOS ring
- 9 Supporting disk
- 10 Safety plate
- 11 Groove nut
- 12 Shim ring
- 13 Idle rotation element
- 14 Setscrew

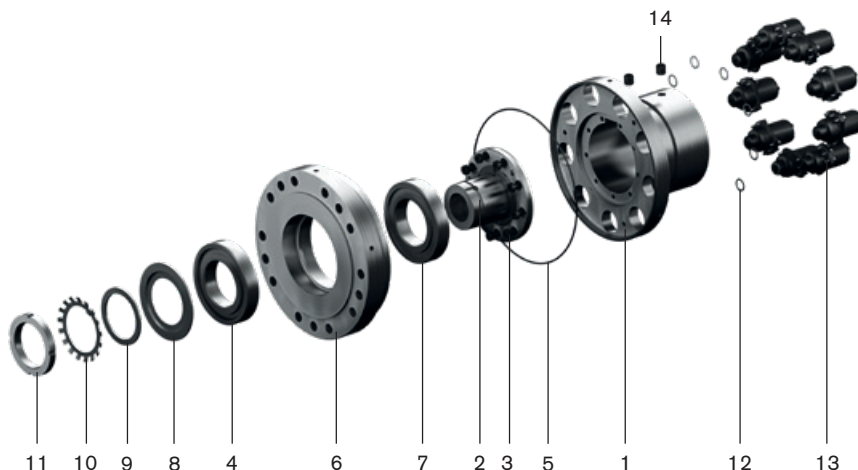

RUFLEX®

KTR-SI

SYNTEX®

SYNTEX®-NC

Torque limiters

KTR-SI Compact

## KTR-SI FRA

# Idle rotation overload system with automatic re-engagement when reversing the direction of rotation

### Design and operation

- Overload protection up to 3,000 Nm
- Idle rotation overload system (load-separating)
- Re-engagement by reversing the direction of rotation, thus optimally suitable for locations difficult to access

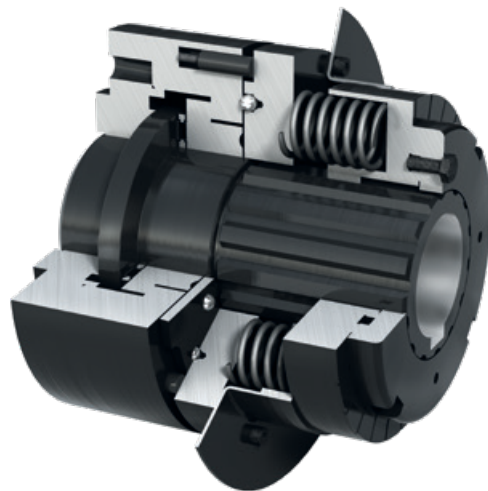

- flange type to connect toothed belt pulleys or sprockets
- Combination with torsionally flexible POLY-NORM® as a shaft-to-shaft connection

Com- ponent	Description
----------------	-------------

- |    |                   |
|----|-------------------|
| 1  | Connection flange |
| 2  | Plain bearing     |
| 3  | Axial disk        |
| 4  | Hub               |
| 5  | Axial bearing     |
| 6  | Bearing flange    |
| 7  | Flange ring       |
| 8  | Balls             |
| 9  | Shifting ring     |
| 10 | Disk springs      |
| 11 | Pressure ring     |
| 12 | Lock washer       |
| 13 | Setting nut       |



### Operating principles

#### 1. Idle rotation design FR/FRE/FRA

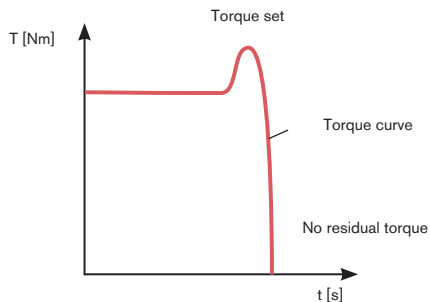

Operating principle of KTR-SI idle rotation couplings:

When achieving the torque set, the coupling rotates. Driving and driven side keep separated due to the idle rotation mechanism, the resulting flywheel mass can slow down in idle state. After eliminating the overload, the coupling can be re-engaged. The re-engagement is effected manually or via a device respectively automatically.

##### Re-engagement of FR

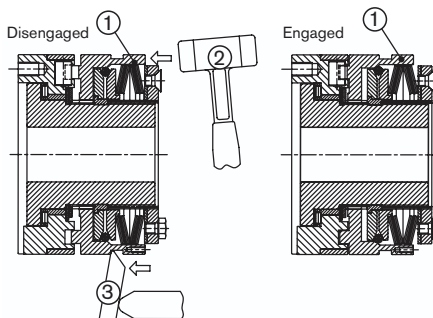

##### Re-engagement of the idle rotation coupling:

Re-engagement is generated by axial pressure on the shifting ring (1). Dependent on the existing resources, accessibility etc., re-engagement can be made in different ways: By several blows of a plastic hammer (2) axially on the shifting ring (see above), via assembly levers (3) or a pneumatic or hydraulic engagement device (automated engagement procedure).

##### Re-engagement of FRE

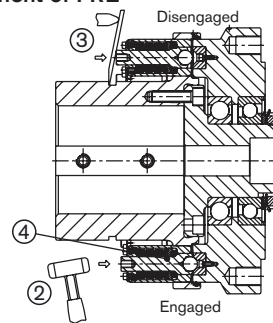

##### Re-engagement of idle rotation elements:

After eliminating the overload, driving and driven side are aligned to each other first. By means of a plastic hammer (2) or a tyre lever (3) the idle rotation elements (4) are manually re-engaged. Re-engagement can be loudly heard. The overload coupling is ready for use again.

##### Re-engagement of FRA

After eliminating the overload the KTR-SI FRA can be re-engaged by reversing the direction of rotation with slow speed (>50 rpm).

#### 2. Ratchet design DK

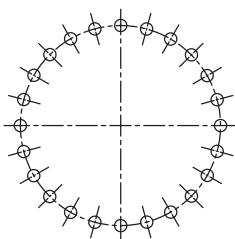

Any engagement after an overload. After eliminating the overload, the balls automatically re-engage with the next following ball indentation.

#### 3. Synchronous design SR

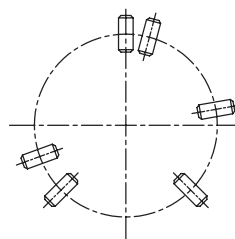

Synchronous engagement after an overload. After eliminating the overload, the balls re-engage automatically after a rotation of 360°. Driving and driven side are always placed in the same position to each other. Other degrees of re-engagement, for example 180°, are also possible.

#### 4. Fail-safe design SGR

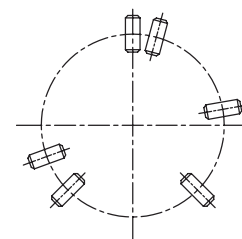

The fail-safe design is purely intended for torque measurement without any ratcheting operation. In case of overload a signal is generated by a limit switch along with mechanical separation of driving and driven side = ratcheting is not possible.

# KTR-SI Overload system

## Flange type

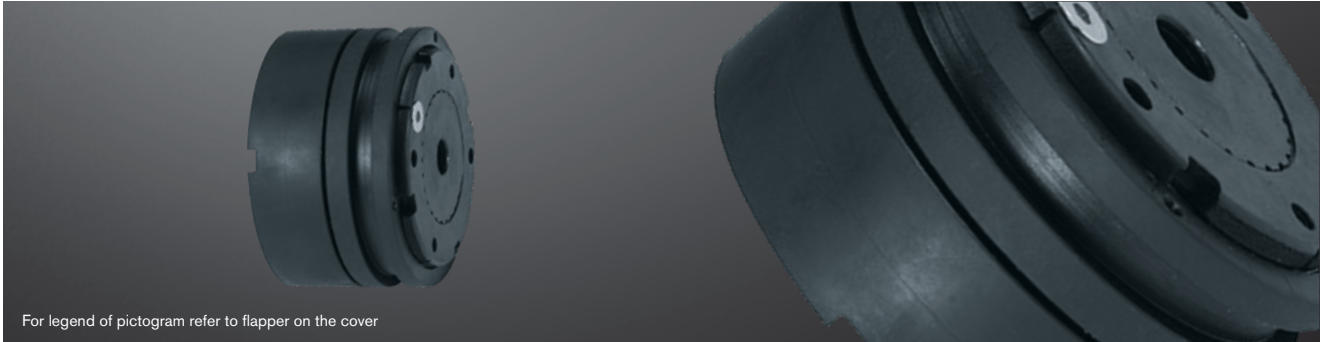

For legend of pictogram refer to flapper on the cover



Type FT

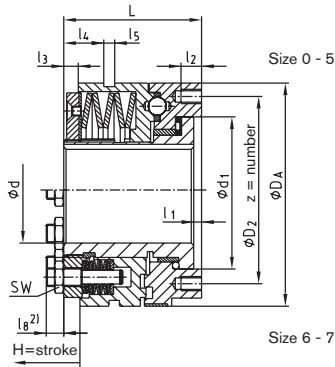

Type KT

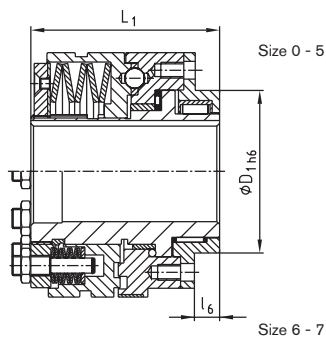

Type LT

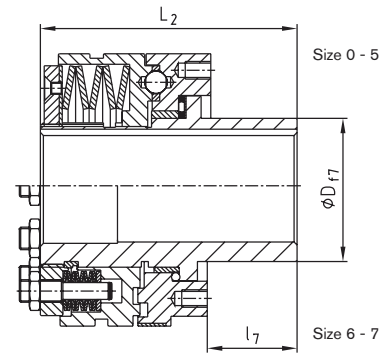

### Technical data

Size	Torques [Nm]												Weight with max. bore [kg]
	Type DK				Type SR and SGR				Type FR				
	T1	T2	T3	T4	T1	T2	T3	T4	T1	T2	T3	$n_{max.}^{3)}$ [rpm]	
0	2.5-5	5-20	–	20-40	5-10	10-40	–	–	5-10	10-20	20-40	6000	0.41
1	6-12	12-25	25-55	55-100	12-25	25-50	50-100	–	12-25	25-50	50-100	5000	1.30
2	12-25	25-50	50-120	120-200	25-50	50-100	100-200	–	25-50	50-100	100-200	4000	2.27
3	25-50	50-100	100-250	200-450	50-100	100-200	200-450	–	50-100	100-200	200-450	3500	3.88
4	50-100	100-200	200-500	500-1000	100-200	200-400	400-800	800-2000	100-200	200-400	400-800	3000	8.34
5	85-250	230-600	300-1000	600-2000	170-450	350-900	600-1800	1200-3400	170-450	350-900	600-1800	2300	13.51
6	180-480	360-960	720-1950	1600-3300	300-750	600-1500	1200-3000	2900-5800	–	–	–	–	21
7	250-520	500-1050	1000-2100	2000-3600	550-1100	1100-2200	2200-4400	3000-8200	–	–	–	–	37

### Dimensions [mm]

Size	Bore d		d <sub>1</sub>	D	D <sub>1</sub>	D <sub>2</sub>	D <sub>A</sub>	l <sub>1</sub>	l <sub>2</sub>	l <sub>3</sub>	l <sub>4</sub>	l <sub>5</sub>	l <sub>6</sub>	l <sub>7</sub>	L	L <sub>1</sub>	L <sub>2</sub>	z	H=stroke			
	Pilot bore	max.																	DK	SR	SGR	FR
0	7	20	41.0	28	38	48	55	4.0	6.5	3.0	7.5	9	8	27.5	38.5	51.0	66.0	6xM5	1.4	1.2	0.6	1.6
1	10	25	60.0	38	50	70	82	4.0	8.0	6.0	11.5	9	10	33.0	52.0	70.0	85.0	6xM5	2.3	1.8	0.8	2.3
2	14	35	78.0	52	60	89	100	5.0	10.0	5.0	12.0	9	12	39.0	61.0	78.0	100.0	6xM6	2.4	2.0	1.1	3.0
3	18	45	90.5	65	80	105	120	5.0	12.0	8.5	21.0	10	12	47.0	78.0	96.0	125.0	6xM8	2.7	2.2	1.2	3.5
4	24	55	105.0	78	100	125	146	6.5	15.0	11.0	27.0	9	16	52.5	100.0	124.5	152.5	6xM10 <sup>1)</sup>	3.7	2.5	1.2	3.8
5	30	65 (70) <sup>4)</sup>	120.5	90	120	155	176	6.5	17.0	12.0	33.0	9	18	57.5	113.5	140.0	171.0	6xM12 <sup>1)</sup>	4.6	3.0	1.6	4.5
6 <sup>2)</sup>	40	80	136.0	108	130	160	200	7.0	20.0	14.0	39.0	9	20	64.0	119.0	150.0	183.0	6xM12 <sup>1)</sup>	5.0	3.5	2.5	–
7 <sup>2)</sup>	50	100 (110) <sup>4)</sup>	168.0	135	160	200	240	8.0	25.0	15.0	46.0	9	25	72.0	141.0	175.0	213.0	6xM16 <sup>1)</sup>	5.5	4.0	2.7	–

<sup>1)</sup> Type T4 SR and SGR: tightening torques according to 12.9

<sup>2)</sup> Size 6: dimension l<sub>8</sub> = 15 mm, size 7: dimension l<sub>8</sub> = 21 mm

<sup>3)</sup> See comments on page 265

<sup>4)</sup> The figure in brackets specifies the max. bore with keyway to DIN 6885 sheet 3 (low-rise design)

Ordering example:

KTR-SI 2	FR	FT	T2	d Ø20	40 Nm
Type/size	Type (DK/SR/SGR/FR)	Type	Disk spring layering	Bore	Torque set

# KTR-SI Overload systems

With torsionally flexible ROTEX®



For legend of pictogram refer to flapper on the cover

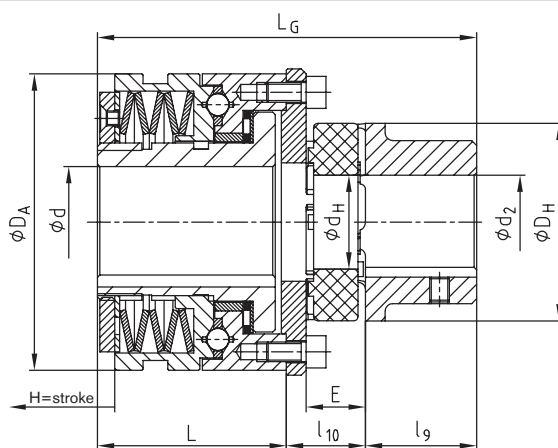

### Technical data

KTR-SI size	Torques [Nm]											
	Type DK				Type SR and SGR				Type FR			
	T1	T2	T3	T4	T1	T2	T3	T4	T1	T2	T3	
0	2.5-5	5-20	-	20-40	5-10	10-40	-	-	5-10	10-20	20-40	
1	6-12	12-25	25-55	55-100	12-25	25-50	50-100	-	12-25	25-50	50-100	
2	12-25	25-50	50-120	120-200	25-50	50-100	100-200	-	25-50	50-100	100-200	
3	25-50	50-100	100-250	200-450	50-100	100-200	200-450	-	50-100	100-200	200-450	
4	50-100	100-200	200-500	500-1000	100-200	200-400	400-800	800-2000	100-200	200-400	400-800	
5	85-250	230-600	300-1000	600-2000	170-450	350-900	600-1800	1200-3400	170-450	350-900	600-1800	
6	180-480	360-960	720-1950	1600-3300	300-750	600-1500	1200-3000	2900-5800	-	-	-	
7	250-520	500-1050	1000-2100	2000-3600	550-1100	1100-2200	2200-4400	3000-8200	-	-	-	

### Technical data – dimensions

KTR-SI size	ROTEX® size	ROTEX® <sup>1)</sup> Torque [Nm]		Max. bore	Dimensions [mm]										H=stroke		
		98 ShA			d	d <sub>2</sub>	d <sub>H</sub>	DH	DA	l <sub>9</sub>	l <sub>10</sub>	E	L	L <sub>G</sub>	Type		
		T <sub>KN</sub>	T <sub>K max</sub>												DK	SR	FR
0	19	17	34	20	25	18	40	55	25	22	16	38.5	85.5	1.4	1.2	1.6	
	28	160	320		40	30	65		35	28.5	20		102				
1	24	60	120	25	35	27	55	82	30	24	18	52	106	2.3	1.8	2.3	
	38	325	650		48	38	80		45	32.5	24		129.5				
2	28	160	320	35	40	30	65	100	35	28	20	61	124	2.4	2.0	3.0	
	48	525	1050		62	51	105		56	38	28		155				
3	38	325	650	45	48	38	80	120	45	32	24	78	155	2.7	2.2	3.5	
	55	685	1370		74	60	120		65	43	30		186				
4	48	525	1050	55	62	51	105	146	56	38	28	100	194	3.7	2.5	3.8	
	75	1920	3840		95	80	160		85	56.5	40		241.5				
5	55	685	1370	65 (70) <sup>2)</sup>	70	60	120	176	65	44	30	113.5	222.5	4.6	3.0	4.5	
	90	3600	7200		110	100	200		100	62	45		275.5				
6	100	4950	9900	80	115	113	225	200	110	72	50	119	301	5.0	3.5	-	
7	110	7200	14400	100 (110) <sup>2)</sup>	125	127	255	240	120	78	55	141	339	5.5	4.0	-	

<sup>1)</sup> See selection of ROTEX® couplings on page 14 et seqq.

<sup>2)</sup> The figure in brackets specifies the max. bore with keyway to DIN 6885 sheet 3 (low-rise design)

Ordering example:

KTR-SI 2	DK	T2	d Ø20	ROTEX® 28	98 ShA	d <sub>2</sub> Ø25	40 Nm
Type/size	Type (DK/SR/SGR/FR)	Disk spring layering	KTR-SI bore	Type/size	Spider	ROTEX® bore	Torque set

# KTR-SI FRE

## Idle rotation overload system

### Flange type



For legend of pictogram refer to flapper on the cover

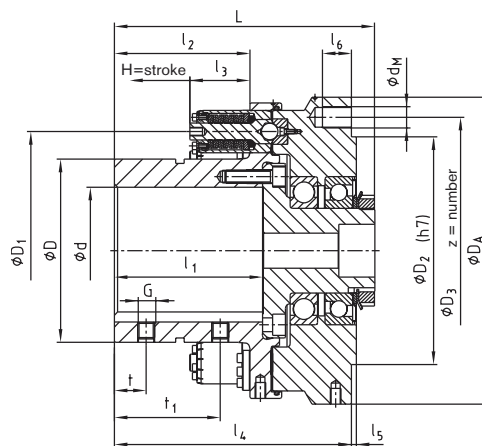

### Torques [Nm]

Size	Type of element	3 idle rotation elements		6 idle rotation elements		9 idle rotation elements	
		min.	max.	min.	max.	min.	max.
9	1T1	800	2600	-	-	-	-
	1T2	1000	4000	2000	8000	-	-
	1T3	2400	5500	4800	11000	-	-
12	1T2	1300	5000	2600	10000	3900	15000
	1T3	2900	6700	5800	13400	8700	20100
15	1T2	1700	6000	3400	12000	5100	18000
	1T3	3500	8200	7000	16400	10500	24600
20	2T2	5000	15000	10000	30000	15000	45000
	2T3	13100	20000	26300	40000	39400	60000

### Technical data – dimensions

Size <sup>1)</sup>	Max. bore	Dimensions [mm]																	Max. permissible forces on the flange connection <sup>2)</sup> [kN]		Speed <sup>3)</sup> [rpm]	Weight with max. bore [kg]		
		d	D	D <sub>1</sub>	D <sub>2</sub>	D <sub>3</sub>	D <sub>A</sub>	l <sub>1</sub>	l <sub>2</sub>	l <sub>3</sub>	l <sub>4</sub>	l <sub>5</sub>	l <sub>6</sub>	G	t	t <sub>1</sub>	L	d <sub>M</sub>	z	pitch			H=stroke	Radial
9	90	135	185	200	225	260	120	110	56.7	197	2.5	17.5	M12	25	75	213.5	12	12	12x30°	5.2	18	13	3300	38
12	120	173	225	215	252	290	140	128	56.7	224	4.5	27.5	M16	30	100	246	20	15	20x18°	5.2	26	18	2300	57
15	150	215	270	245	282	324	170	160	56.7	258	4.5	27.5	M20	40	120	281	20	15	20x18°	5.2	30	20	2050	81
20	200	285	370	330	375	460	220	200	89.4	341	5	33.0	M20	50	150	366	24	18	24x15°	8.9	50	40	1550	211

<sup>1)</sup> Other sizes on request

<sup>2)</sup> Larger forces on request

<sup>3)</sup> Higher speeds on request, see comments on page 265



### Special type:

- KTR-SI FRE with sprocket
- Available as a complete subassembly with preset torque

### Ordering example:

KTR-SI FRE 12	1T2	9	d Ø85	7500 Nm
Type/size	Type of element	Number of idle rotation elements	KTR-SI FRE bore	Torque set

# KTR-SI FRE

## Idle rotation overload system

With torsionally flexible ROTEX®

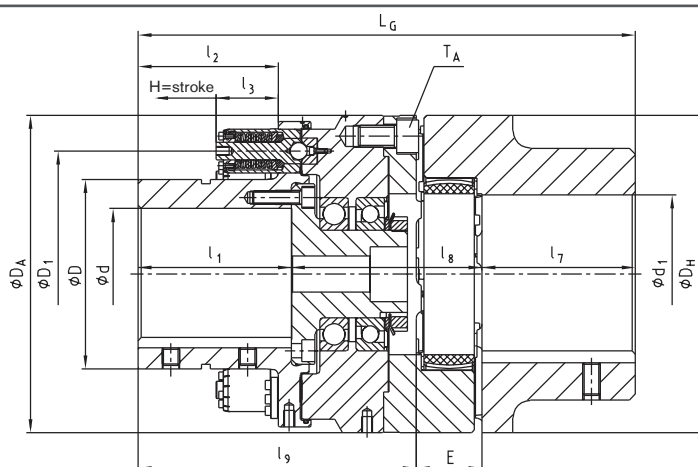

Torques [Nm]

Size	Type of element	3 idle rotation elements		6 idle rotation elements		9 idle rotation elements	
		min.	max.	min.	max.	min.	max.
9	1T1	800	2600	–	–	–	–
	1T2	1000	4000	2000	8000	–	–
	1T3	2400	5500	4800	11000	–	–
12	1T2	1300	5000	2600	10000	3900	15000
	1T3	2900	6700	5800	13400	8700	20100
15	1T2	1700	6000	3400	12000	5100	18000
	1T3	3500	8200	7000	16400	10500	24600
20	2T2	5000	15000	10000	30000	15000	45000
	2T3	13100	20000	26300	40000	39400	60000

Technical data – dimensions

Size <sup>1)</sup>	ROTEX®		Max. bore		Dimensions [mm]														TA [Nm]	Speed <sup>2)</sup> [rpm]	Weight with max. bore [kg]	
	Size	Torque <sup>3)</sup> [Nm] 64 ShD		d	d1	D	D1	DH	DA	I1	I2	I3	I7	I8	I9	I217	E	LG				H=stroke
		TKN	TK max																			
9	90	4500	9000	90	110	135	185	200	260	120	110	56.7	100	133	217	45	362	5.2	117	3300	59	
12	125	12500	25000	120	145	173	225	290	290	146	130	56.7	140	165	254	60	454	5.2	560	2300	106	
15	140	16000	32000	150	160	215	270	320	324	170	160	56.7	155	176	292	65	512	5.2	560	2050	147	
20	180	35000	70000	200	200	285	370	420	460	220	200	88.4	195	227	381	85	661	8.9	970	1550	349	

<sup>1)</sup> Other sizes on request

<sup>2)</sup> Higher speeds on request, see comments on page 265

<sup>3)</sup> See selection of ROTEX® couplings on page 14 et seqq.

### Special type:



- KTR-SI FRE with torsionally flexible pin & bush coupling REVOLEX® KX-D and limitation of axial backlash
- KTR-SI FRE with torsionally stiff all-steel gear coupling GEARex® and integrated brake disk
- KTR-SI FRE with torsionally stiff laminae coupling RADEX®-N and integrated brake disk

### Ordering example:

KTR-SI FRE 12	1T3	9	d Ø85	ROTEX® 125	98 ShA	d1 Ø85	12000 Nm
Type/size	Type of element	Number of idle rotation elements	KTR-SI FRE bore	Type/size	Spider	ROTEX® bore	Torque set

# KTR-SI FRE

## Idle rotation overload system

Customised type (on request)



For legend of pictogram refer to flapper on the cover

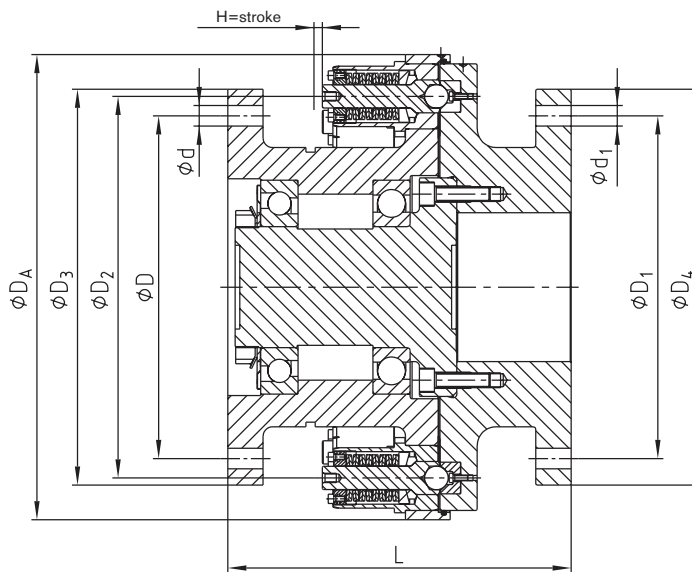

Torques [Nm]									
Size	Type of element	3 idle rotation elements		6 idle rotation elements		9 idle rotation elements		12 idle rotation elements	
		min.	max.	min.	max.	min.	max.	min.	max.
00-1	1T1	1200	3800	2400	7600	3600	11400	-	-
	1T2	1700	6000	3400	1200	5100	18000	-	-
	1T3	3500	8200	7000	16400	10500	24600	-	-
00-2	2T1	-	-	6800	17200	10200	25800	13600	34400
	2T2	-	-	11700	31900	17550	47850	23400	63800
	2T3	-	-	21200	43000	32400	64500	42400	86000
00-3	3T1	-	-	23000	78000	34500	117000	46000	156000
	3T2	-	-	47000	108000	70500	162000	94000	216000

Technical data – dimensions																										
Size	GEARex®			RADEX®-N			Max. bore			Dimensions [mm]																
	Size	T <sub>KN</sub>	T <sub>Kmax.</sub>	Size	T <sub>KN</sub>	T <sub>Kmax.</sub>	d <sub>2</sub> , d <sub>3</sub>	d <sub>4</sub>	d <sub>5</sub>	d, d <sub>1</sub>	D, D <sub>1</sub>	D <sub>2</sub>	D <sub>3</sub> , D <sub>4</sub>	D <sub>5</sub>	D <sub>6</sub>	D <sub>A</sub>	I <sub>1</sub> , I <sub>2</sub>	I <sub>3</sub>	I <sub>4</sub>	E	E <sub>1</sub>	L	L <sub>G</sub>	L <sub>G1</sub>	H=stroke	
00-1	35	17000	34000	136	17500	35000	133	135	140	custom-ised	custom-ised	270	custom-ised	280	300	324	105	135	126	256	custom-ised	custom-ised	466	723	723	5.2
00-2	55	65000	130000	208	70000	140000	210	200	250	custom-ised	custom-ised	410	custom-ised	425.5	425.5	500	175	200	245	373	custom-ised	custom-ised	723	1000	1000	8.9
00-3	85	225000	450000	288	200000	400000	325	290	350	custom-ised	custom-ised	540	custom-ised	585	567	655	292	280	335	416	custom-ised	custom-ised	1000	1000	1000	13.6

Ordering example:	KTR-SI FRE 00-2	T2	6	Ø350	Ø400	349	25000 Nm
	Type/size	Type of element	Number of idle rotation elements	Flange diameter ØD <sub>3</sub>	Flange diameter ØD <sub>4</sub>	Total length L	Torque set

Other types and combinations available on request.

Type 00 with GEARex®

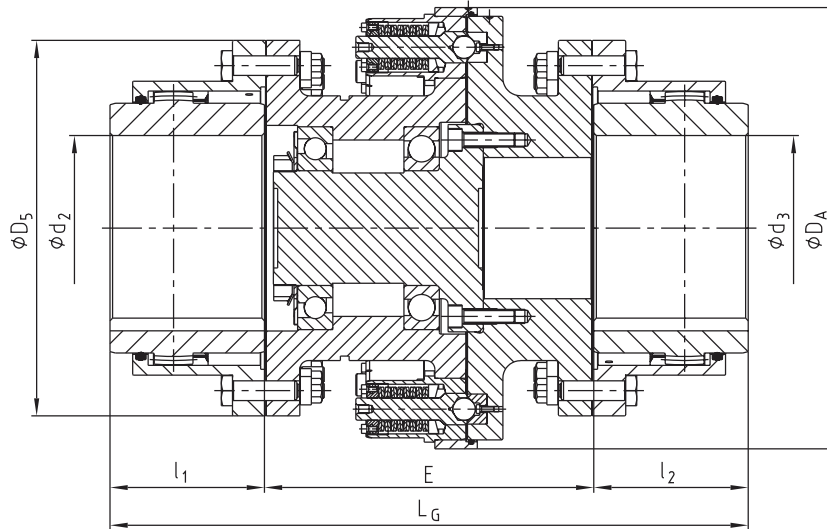

Type 00 with RADEX®-N

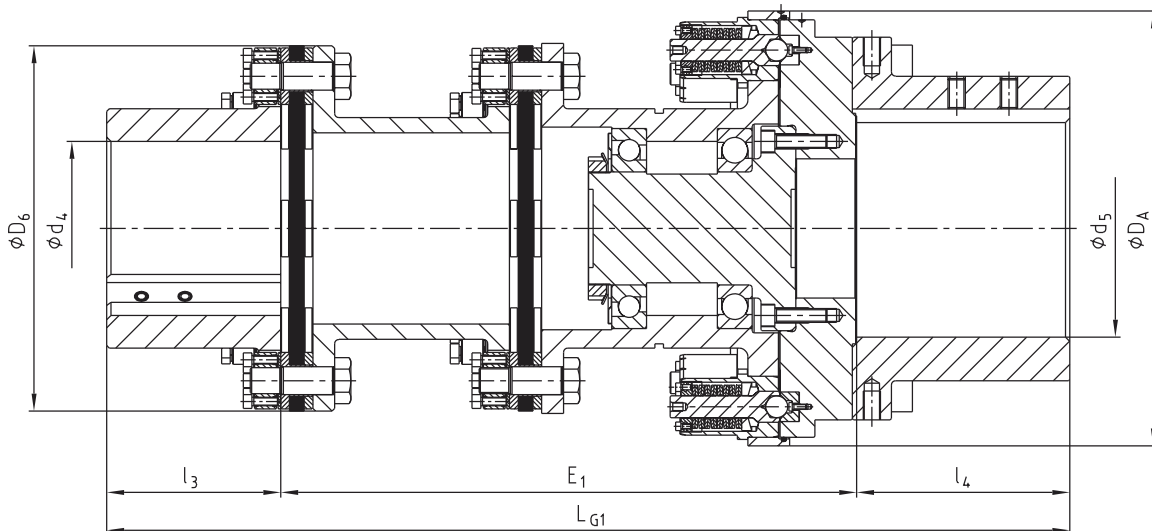

RUFLEX®

KTR-SI

SYNTEX®

SYNTEX®-NC

Torque  
limiters

KTR-SI Compact

# KTR-SI FRA

## Idle rotation overload system with automatic re-engagement when reversing the direction of rotation

### Flange type FT

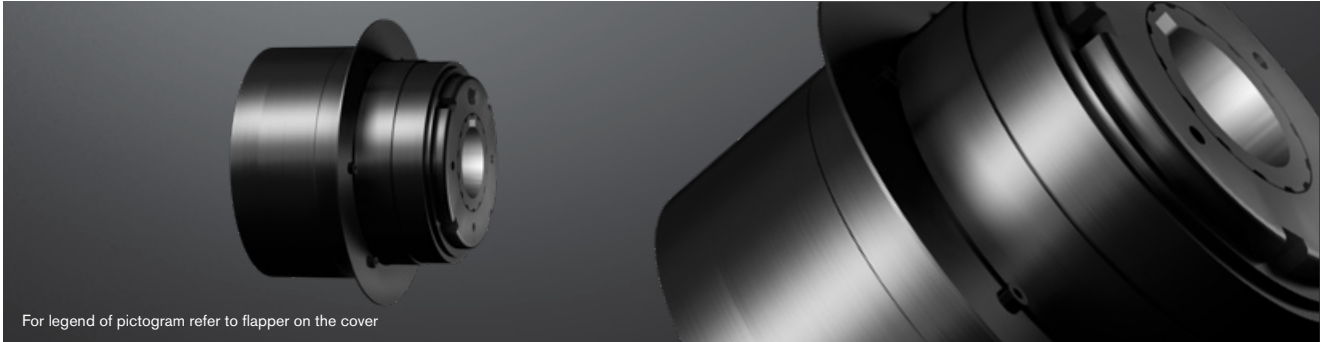

For legend of pictogram refer to flapper on the cover

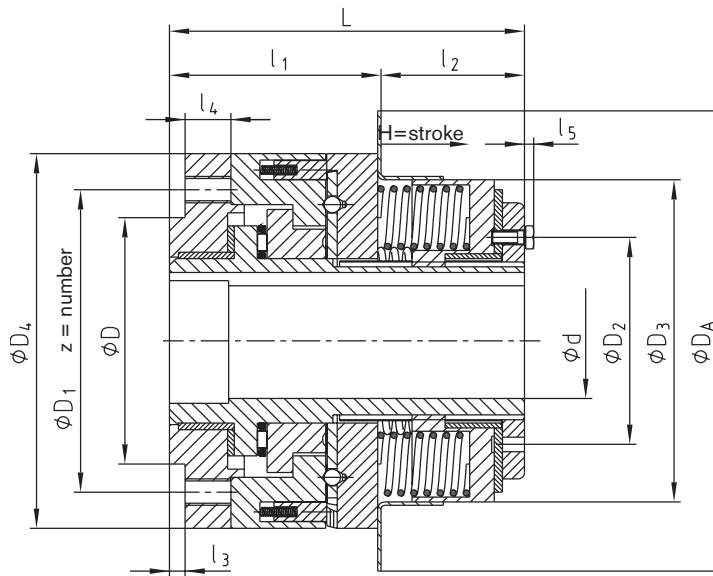

Torques [Nm]				
Size	T1	T2	T3	T4
2	5-20	15-70	40-135	80-260
3	24-104	57-360	110-540	245-730
4	45-210	145-435	340-960	465-1320
5	90-415	240-640	490-1880	1060-3000

Technical data – dimensions																			
Size	Bore d		Dimensions [mm]															Speed <sup>1)</sup> [rpm]	Weight with max. bore [kg]
	Pilot bore	max.	D j7	D1	D2	D3	D4	DA	l1	l2	l3	l4	l5	L	z	H=stroke			
2	22	35	75	92	70	98	114	140	63	45	4.7	14	-	108	6xM8	2.8	3600	5	
3	22	45	95	114	77	131	149	184	69	42	4.7	15	3.5	111	7xM10	3.5	3600	10	
4	25	55	122	144	88	147	166	203	75	46	4.7	15	4.0	121	8xM12	3.5	2000	13	
5	30	80	155	184	152	196	223	279	94	70	6.3	23	2.3	164	8xM16	4.4	2000	32	

<sup>1)</sup> See comments on page 265

Ordering example:	KTR-SI FRA 3	FT	T3	d Ø35	300 Nm
	Type/size	Type	Torque setting range	KTR-SI FRE bore	Torque set

# KTR-SI FRA

## Idle rotation overload system with automatic re-engagement when reversing the direction of rotation

With torsionally flexible ROTEX®



For legend of pictogram refer to flapper on the cover

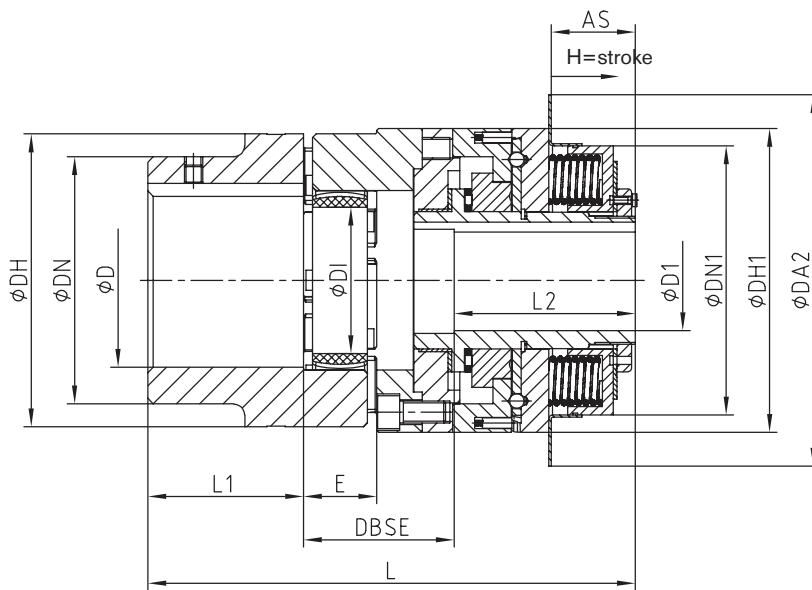

Torques [Nm]				
KTR-SI FRA size	T1	T2	T3	T4
2	5-20	15-70	40-135	80-260
3	24-104	57-360	110-540	245-730
4	45-210	145-435	340-960	465-1320
5	90-415	240-640	490-1880	1060-3000

Technical data – dimensions																							
KTR-SI FRA size	ROTEX®			Max. bore		Dimensions [mm]															T <sub>A</sub> [Nm]	Speed <sup>1)</sup> [rpm]	Weight with max. bore [kg]
	Size	Torque [Nm]		D	D1	DN	DN1	DH1	DH	DA2	DI	L1	AS	DBSE	E	L2	LG	H=stroke					
2	38	325	650	35	48	70	98	114	80	140	38	45	45	35	24	108	188	2.8	34	3600	7.5		
3	65	940	1880	45	80	115	131	149	135	184	68	75	42	46.3	35	111	232.3	3.5	67	3600	17		
4	75	1920	3840	55	95	135	147	166	160	203	80	85	46	60.3	40	121	266.3	3.5	67	2000	23.5		
5	90	3600	7200	80	110	160	196	223	200	279	100	100	70	58.7	45	164	322.7	4.4	115	2000	51		

<sup>1)</sup> See comments on page 265  
<sup>2)</sup> See selection of ROTEX® couplings on page 14 et seqq.

Ordering example:	KTR-SI FRA 3	T3	d Ø30	ROTEX® 65	98 ShA	d <sub>2</sub> Ø40	250 Nm
	Type/size	Disk spring layering	KTR-SI bore	Type/size	Spider	ROTEX® bore	Torque set

# SYNTEX®

## Backlash-free overload systems

### Design and operation

- Backlash-free, torsionally stiff overload protection up to 400 Nm, suitable for reversing operation
- Disconnection of the drive in case of overload
- Reduction of torque peaks
- High response accuracy, even after a long operating period
- Easy integration of customer components
- Compact design, low mass moment of inertia
- User-variable due to modular system
- Special disk springs available for special applications

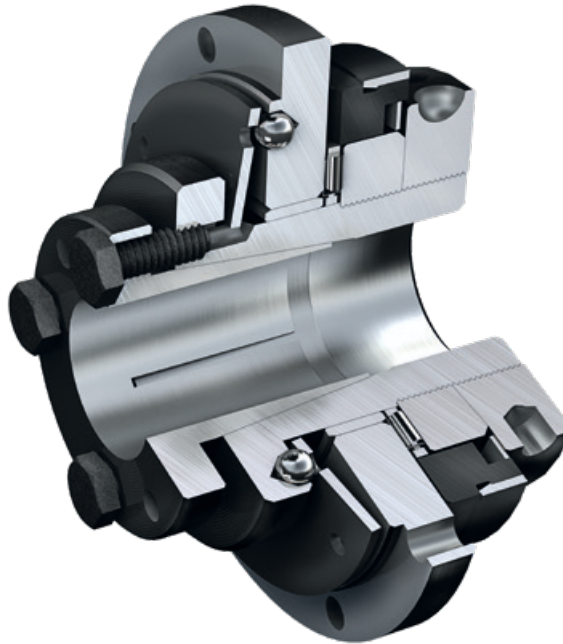

- Low-cost protection even for simple drives
- Easy assembly and torque setting
- Maintenance-free
- Insensitive to oil and grease
- Long service life due to small internal loads
- Backlash-free shaft-hub-connections
- Any or synchronous re-engagement
- Automatically ready for operation again

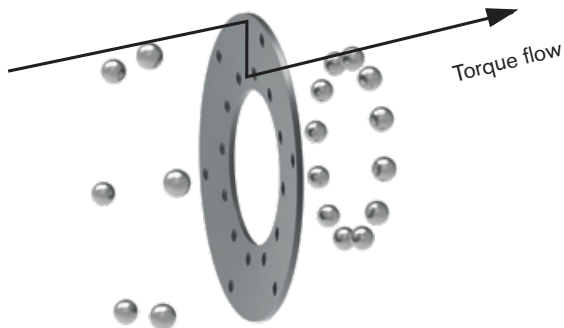

SYNTEX® is an overload system with positive locking operation. The punched disk spring is a component serving for transmitting the torque.

**SYNTEX®**  
Overload system with mounting flange



**SYNTEX®**  
Overload system with sprocket



**SYNTEX®**  
Overload system with ROTEX® GS

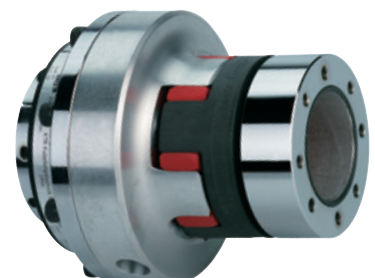

**Operating principles**

Ratchet design DK

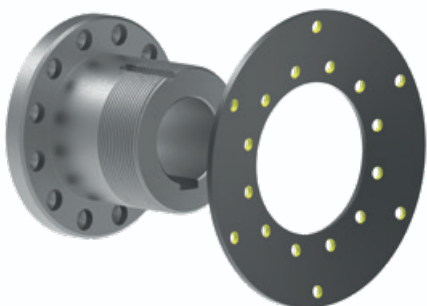

Synchronous design SK

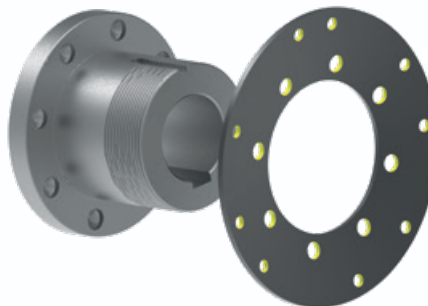

If the torque set is exceeded, a relative movement is generated between the driving and driven side. The transmittable torque is reduced to a low residual figure.

The balls leave the indentations of the disk spring. After eliminating the overload, the balls engage automatically with the next following ball indentation of the disk spring.

If the torque set is exceeded, a relative movement is generated between the driving and driven side. The transmittable torque is reduced to a low residual figure.

The balls leave the indentations of the disk spring. After eliminating the overload, the balls re-engage automatically with the disk springs after a rotation of 360° subject to their special pitch. Driving and driven side are always in the same position to each other (other degrees of re-engagement, for example 180°, are also possible).

Signal by limit switch or sensor in case of overload

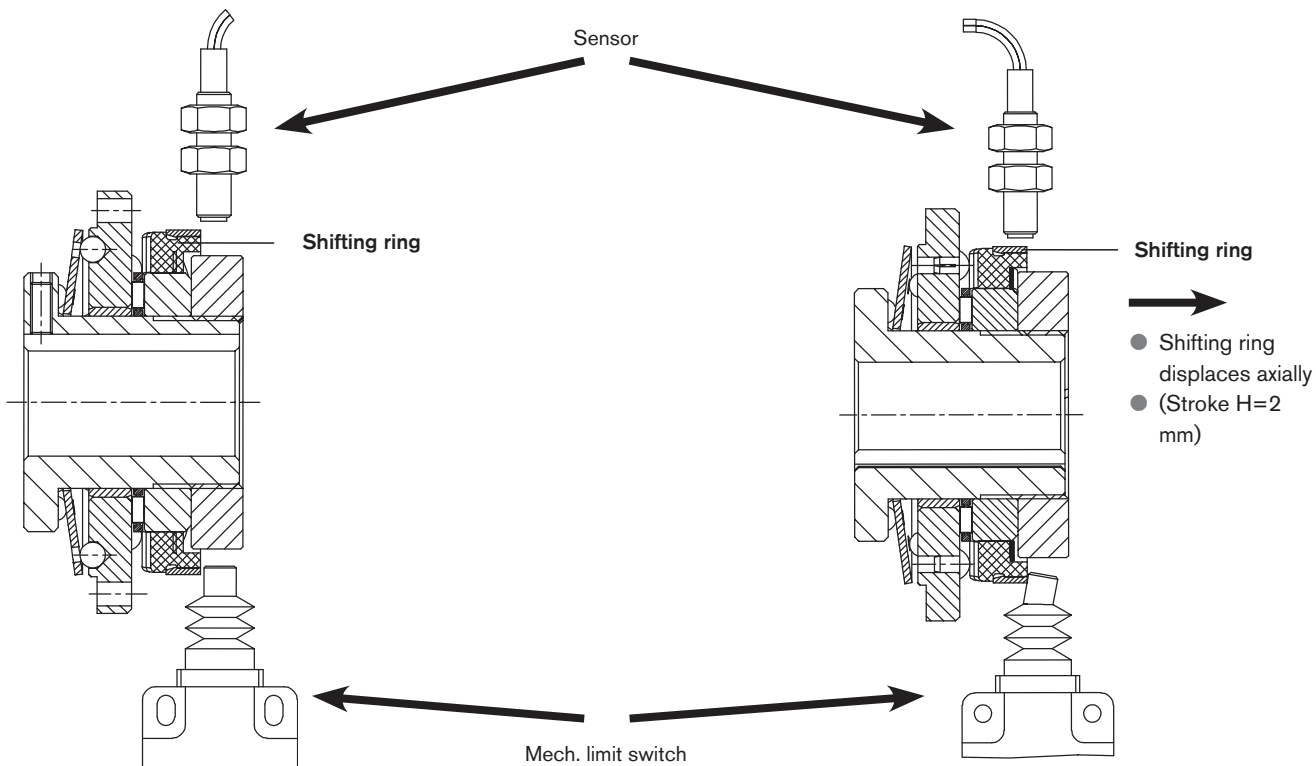

**Normal operation:**

No signal by sensor or mechanical limit switch.

**In case of overload:**

The axial motion of the shifting ring activates the sensor resp. mechanical limit switch. The resulting signal can be used for control operation (e. g. motor stop).

RUFLEX®

KTR-SI

SYNTEX®

SYNTEX®-NC

Torque limiters

KTR-SI Compact

# SYNTEX®

## Backlash-free overload systems

### Flange type

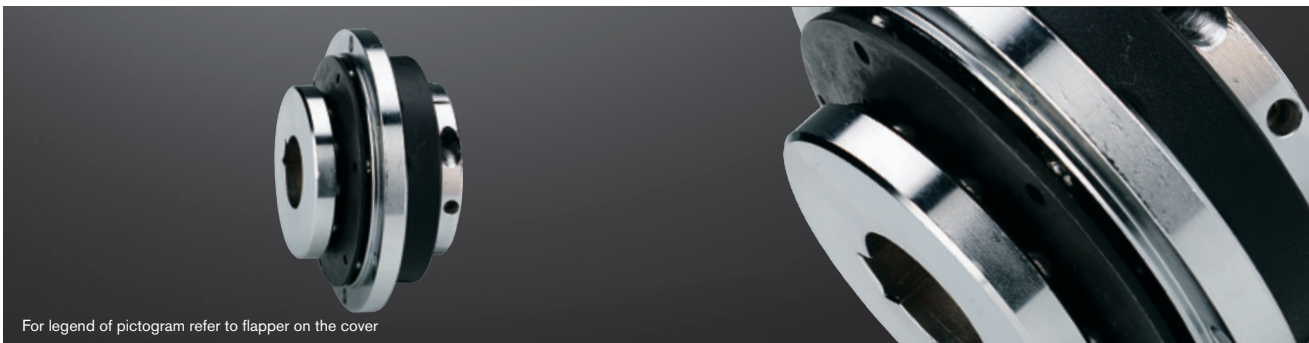

For legend of pictogram refer to flapper on the cover



#### Technical data – dimensions

Size	Torques [Nm]				Max. speed <sup>1)</sup> [rpm]	Dimensions [mm]															
	Ratchet design DK		Synchronous design SK			Max. bore d	D	D <sub>1</sub>	D <sub>2</sub>	D <sub>3</sub>	D <sub>4</sub>	D <sub>A</sub>	l <sub>1</sub>	l <sub>2</sub>	l <sub>3</sub>	l <sub>4</sub>	l <sub>5</sub>	d <sub>L</sub>	L	z	H=stroke
	DK1	DK2	SK1	SK2																	
20	6-20	15-30	10-20	20-65	1500	20	48	54	61.5	65	71	80	8	2	16	6	35	4.5	45	8	2
25	20-60	45-90	25-65	40-100	1500	25	60	68	80	81	89	98	8	2	17	8	39	5.5	50	8	2
35	25-80	75-150	30-100	70-180	1000	35	75	78	91	102	110	120	10	2	21	10	42	5.5	60	12	2
50	60-180	175-300	80-280	160-400	1000	50	105	108	121	142	152	162	12	2	25	13	56	6.6	70	12	2

#### Dimensions – Hub type 4.5

Size	Dimensions [mm]							Clamping screws	Tightening torque T <sub>A</sub> [Nm]
	d <sub>1</sub> max.	l <sub>6</sub>	l <sub>7</sub>	l <sub>8</sub>	L <sub>1</sub>	s			
20	20	9	3.5	23	54	3	4 x M5	8.5	
25	25	11	4.0	28	61	4	4 x M6	14	
35	35	10	4.0	31	70	4	4 x M6	14	
50	50	12	4.0	37	82	6	4 x M6	14	

#### Transmittable friction torques T<sub>R</sub> [Nm] (clearance H7/h6) of hub type 4.5

Size	Ø12	Ø14	Ø15	Ø16	Ø17	Ø18	Ø19	Ø20	Ø22	Ø23	Ø24	Ø25	Ø28	Ø30	Ø32	Ø35	Ø38	Ø40	Ø42	Ø45	Ø48	Ø50
20	45	62	71	81	92	103	115	127														
25		72	83	95	107	120	133	148	179	196	213	231										
35									127	139	152	165	207	237	270	323						
50																238	281	311	343	394	448	486

<sup>1)</sup> See comments on page 265

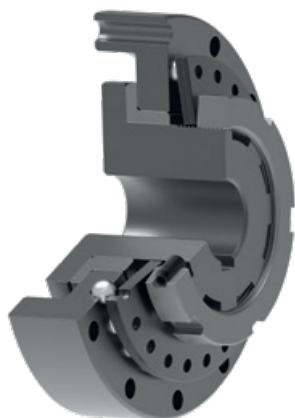

#### Special type:

- SYNTEX® 35 spec. with integrated flange
- Performance range up to 360 Nm
- Adjustment of flange to ambient components possible

Ordering example:

SYNTEX® 25	d Ø20	DK1	1.0	45 Nm
Type/size	Bore	Type (DK/SK)	Hub type	Torque set

Hub type 1.0

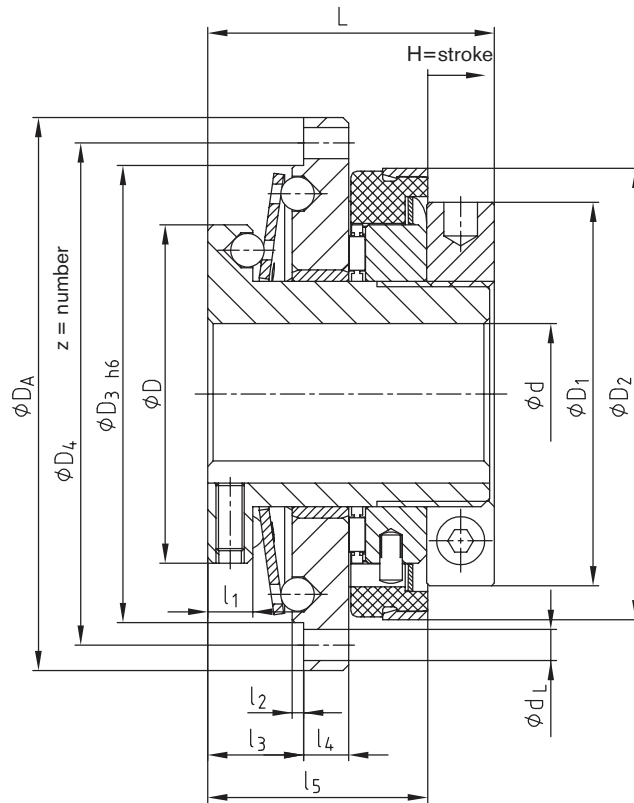

Hub type 4.5

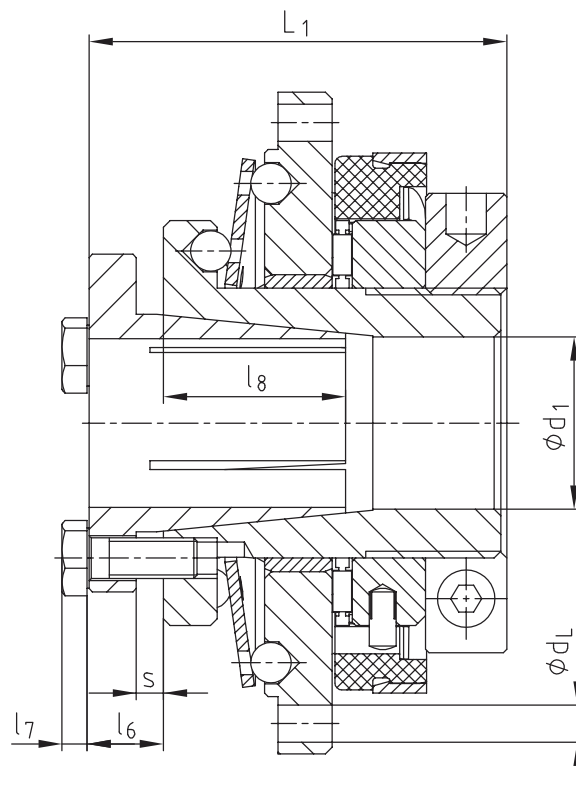

KTR-SI

SYNTEX®

SYNTEX®-NC

KTR-SI Compact

Torque limiters

# SYNTEX®

## Backlash-free overload systems

### With sprocket



For legend of pictogram refer to flapper on the cover



#### Technical data – dimensions

Size	Torque [Nm]				Max. speed <sup>2)</sup> [rpm]	Dimensions [mm]											
	Ratchet design DK		Synchronous design SK			Max. bore d	Standard sprocket <sup>1)</sup>			D	D <sub>1</sub>	D <sub>2</sub>	l <sub>1</sub>	l <sub>3</sub>	l <sub>5</sub>	L	H=stroke
	DK1	DK2	SK1	SK2													
20	6-20	15-30	10-20	20-65	1500	20	06 B-1 ( <sup>3</sup> / <sub>8</sub> x <sup>7</sup> / <sub>32</sub> ) z = 25			48	54	61.5	8	14	33	45	2
25	20-60	45-90	25-65	40-100	1500	25	08 B-1 ( <sup>1</sup> / <sub>2</sub> x <sup>5</sup> / <sub>16</sub> ) z = 24			60	68	80	8	15	37	50	2
35	25-80	75-150	30-100	70-180	1000	35	08 B-1 ( <sup>1</sup> / <sub>2</sub> x <sup>5</sup> / <sub>16</sub> ) z = 29			75	78	91	10	19	41	60	2
50	60-180	175-300	80-280	160-400	1000	50	12 B-1 ( <sup>3</sup> / <sub>4</sub> x <sup>7</sup> / <sub>16</sub> ) z = 27			105	108	121	12	23	52	70	2

#### Dimensions – Hub type 4.5

Size	Dimensions [mm]							Clamping screws	Tightening torque T <sub>A</sub> [Nm]
	d <sub>1</sub> max.	l <sub>6</sub>	l <sub>7</sub>	l <sub>8</sub>	L <sub>1</sub>	s			
20	20	9	3.5	23	54	3	4 x M5	8.5	
25	25	11	4.0	28	61	4	4 x M6	14	
35	35	10	4.0	31	70	4	4 x M6	14	
50	50	12	4.0	37	82	6	4 x M6	14	

#### Transmittable friction torques T<sub>R</sub> [Nm] (clearance H7/h6) of hub type 4.5

Size	Ø12	Ø14	Ø15	Ø16	Ø17	Ø18	Ø19	Ø20	Ø22	Ø23	Ø24	Ø25	Ø28	Ø30	Ø32	Ø35	Ø38	Ø40	Ø42	Ø45	Ø48	Ø50	
20	45	62	71	81	92	103	115	127															
25		72	83	95	107	120	133	148	179	196	213	231											
35									127	139	152	165		207	270	323							
50															238	281	311	343	394	448	486		

<sup>1)</sup> z = min. number of teeth required / Other sprockets available on request

<sup>2)</sup> See comments on page 265



#### Special type:

- Standard SYNTEX® with integrated toothed belt pulley or sprocket
- Available ready for assembly with the torque set
- Reduction of components by integration of components
- Available both as a ratchet and synchronous design
- torque setting possible while in place
- Finish bore according to ISO fit H7, feather keyway according to DIN 6885, sheet 1 [JS9]
- Also available with a frictionally engaged shaft-hub-connection (hub type 4.5)

#### Ordering example:

SYNTEX® 25	DK1	1.0	d Ø20	08 B-1 ( <sup>1</sup> / <sub>2</sub> x <sup>5</sup> / <sub>16</sub> ), z = 29	45 Nm
Type/size	Type (DK/SK)	Hub type	Bore	Sprocket	Torque set

Hub type 1.0

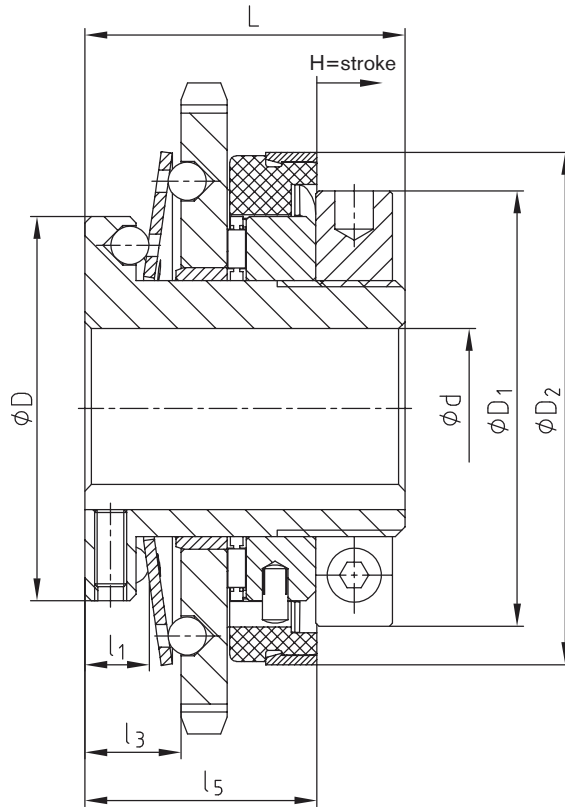

Hub type 4.5

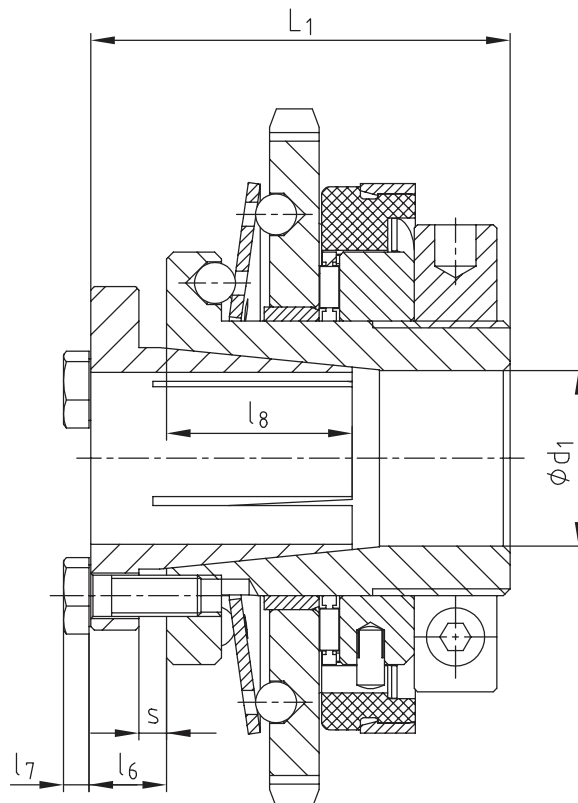

KTR-SI

SYNTEX®

SYNTEX®-NC

KTR-SI Compact

Torque limiters

# SYNTEX®

## Backlash-free overload systems

### With toothed belt pulley

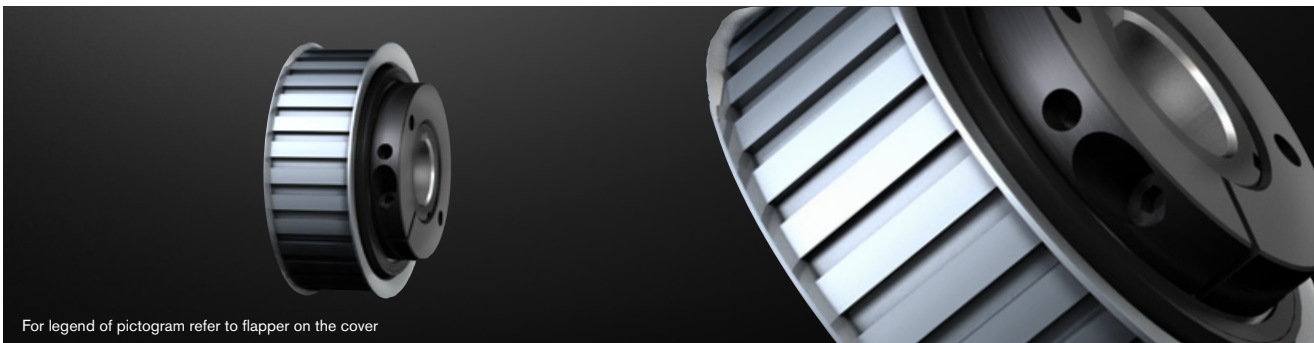

For legend of pictogram refer to flapper on the cover



Hub type 1.0

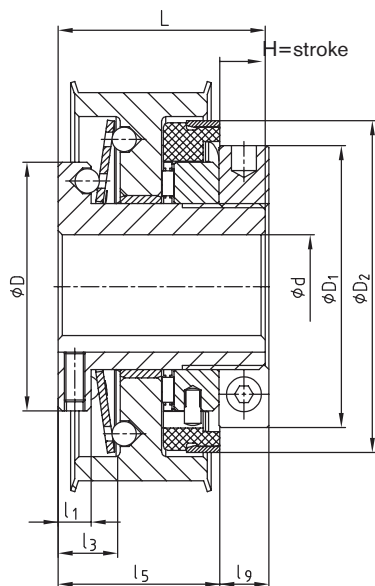

Hub type 4.5

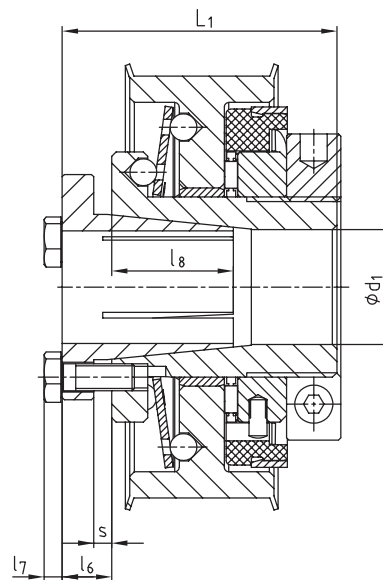

#### Technical data – dimensions

Size	Torques [Nm]				Max. speed <sup>2)</sup> [rpm]	Dimensions [mm]										
	Ratchet design DK		Synchronous design SK			Max. bore	Toothed belt pulley		D	D <sub>1</sub>	D <sub>2</sub>	l <sub>1</sub>	l <sub>3</sub>	l <sub>5</sub>	L	H=stroke
	DK1	DK2	SK1	SK2			d	T10 <sup>1)</sup>								
20	6-20	15-30	10-20	20-65	1500	20	T10, z = 24	AT10, z = 24	48	54	61.5	8	14	35	45	2
25	20-60	45-90	25-65	40-100	1500	25	T10, z = 30	AT10, z = 30	60	68	80	8	15	39	50	2
35	25-80	75-150	30-100	70-180	1000	35	T10, z = 36	AT10, z = 36	75	78	91	10	19	42	60	2
50	60-180	175-300	80-280	160-400	1000	50	T10, z = 48 <sup>3)</sup>	AT10, z = 48 <sup>3)</sup>	105	108	121	12	23	56	70	2

#### Dimensions – Hub type 4.5

Size	Max. bore	Dimensions [mm]						Clamping screws	Tightening torque T <sub>A</sub> [Nm]
		d <sub>1</sub>	l <sub>6</sub>	l <sub>7</sub>	l <sub>8</sub>	l <sub>9</sub>	L <sub>1</sub>		
20	20	9	3.5	23	10	54	3	4 x M5	8.5
25	25	11	4.0	28	11	61	4	4 x M6	14
35	35	10	4.0	31	13	70	4	4 x M6	14
50	50	12	4.0	37	14	82	6	4 x M6	14

#### Transmittable friction torques T<sub>R</sub> [Nm] (clearance H7/h6) of hub type 4.5

Size	Ø12	Ø14	Ø15	Ø16	Ø17	Ø18	Ø19	Ø20	Ø22	Ø23	Ø24	Ø25	Ø28	Ø30	Ø32	Ø35	Ø38	Ø40	Ø42	Ø45	Ø48	Ø50
20	45	62	71	81	92	103	115	127														
25		72	83	95	107	120	133	148	179	196	213	231										
35									127	139	152	165	207	237	270	323						
50															238	281	311	343	394	448	486	

<sup>1)</sup> z = min. number of teeth required / Other sizes available on request

<sup>2)</sup> See comments on page 265

<sup>3)</sup> Without flanged wheel

Ordering example:

SYNTEX® 25	DK1	1.0	d Ø20	AT10, z = 24	32	45 Nm
Type/size	Type (DK/SK)	Hub type	Bore	Toothed belt pulley	Width of toothed belt pulley	Torque set

# SYNTEX®

## Backlash-free overload systems

With backlash-free ROTEX® GS



For legend of pictogram refer to flapper on the cover



Hub type 1.0

Hub type 1.0

Hub type 6.0

Hub type 4.5

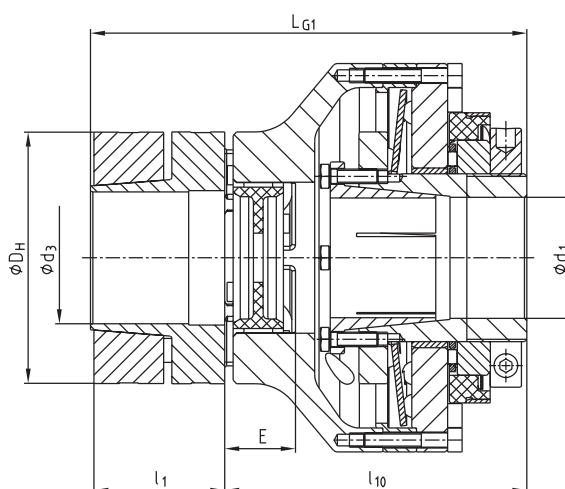
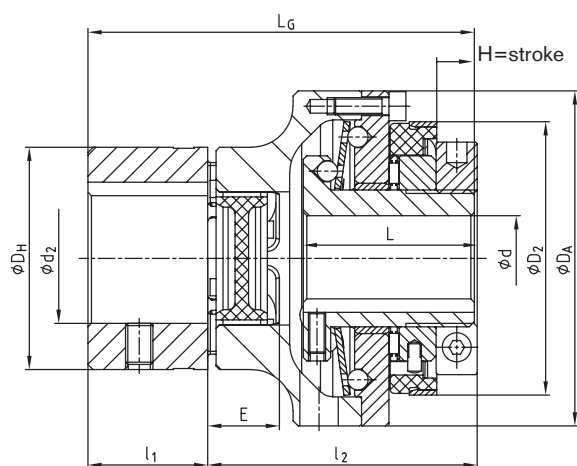

### Technical data – dimensions

SYNTEX® size	ROTEX® GS size	Torques [Nm]								Max. speed <sup>2)</sup> [rpm]	Dimensions [mm]												
		Ratchet design DK		Synchronous design SK		ROTEX® GS <sup>1)</sup> 98 ShA-GS		Max. bore				D <sub>2</sub>	DH	DA	l <sub>1</sub>	l <sub>2</sub>	l <sub>10</sub>	E	L	L <sub>G</sub>	L <sub>G1</sub>	H=stroke	
		DK1	DK2	SK1	SK2	T <sub>KN</sub>	T <sub>K max</sub>	d	d <sub>1</sub>		d <sub>2</sub>												d <sub>3</sub>
20	24	6-20	15-30	10-20	20-65	60	120	1500	20	20	28	28 <sup>3)</sup>	61.5	55	80	30	70	83	18	45	100	113	2
25	28	20-60	45-90	25-65	40-100	160	320	1500	25	25	38	38 <sup>3)</sup>	80	65	98	35	78	91	20	50	113	126	2
35	38	25-80	75-150	30-100	70-180	325	650	1000	35	35	45	48 <sup>3)</sup>	91	80	120	45	91	105.5	24	60	136	150.5	2
50	48	60-180	175-300	80-280	160-400	525	1050	1000	50	50	62	55 <sup>3)</sup>	121	105	162	56	111	126	28	70	167	182	2

### Transmittable friction torques T<sub>R</sub> [Nm] (clearance H7/h6) of hub type 4.5

Size	Ø12	Ø14	Ø15	Ø16	Ø17	Ø18	Ø19	Ø20	Ø22	Ø23	Ø24	Ø25	Ø28	Ø30	Ø32	Ø35	Ø38	Ø40	Ø42	Ø45	Ø48	Ø50
20	45	62	71	81	92	103	115	127														
25		72	83	95	107	120	133	148	179	196	213	231										
35									127	139	152	165	207	237	270	323						
50																238	281	311	343	394	448	486

<sup>1)</sup> See selection of ROTEX® GS couplings on page 22 et seqq.

<sup>2)</sup> See comments on page 265

<sup>3)</sup> For transmittable friction torques T<sub>R</sub> [Nm] of ROTEX® GS hub type 2.8 or 6.0 refer to mounting instructions of ROTEX® GS

Ordering example:

SYNTEX® 25	DK1	1.0	d Ø20	ROTEX® GS 28	98 ShA-GS	1.0	d <sub>2</sub> Ø25	50 Nm
Type/size	Type	Hub type	Bore	Type/size	Spider	Hub type	ROTEX® GS bore	Torque set

# SYNTEX®-NC / KTR-SI Compact Backlash-free overload systems

## Design and operation

The design of the backlash-free overload systems SYNTEX®-NC and KTR-SI Compact is based on a spring-preloaded and positive-locking ball engagement principle allowing for high repeatability and short response times. Moreover, an integrated groove ball bearing provides for the option of direct assembly of toothed belt pulleys, special flanges or other components. Main applications are latest machine tools, control and positioning technology as well as packaging machines and special purpose machinery.

Both systems make use of disk springs with a degressive spring characteristic curve the preset prestress of which drops during the disengaging process. As a result driving and driven end are reliably separated from each other within some milliseconds with the wear on the components being simultaneously reduced to a minimum.

Spring characteristic curve

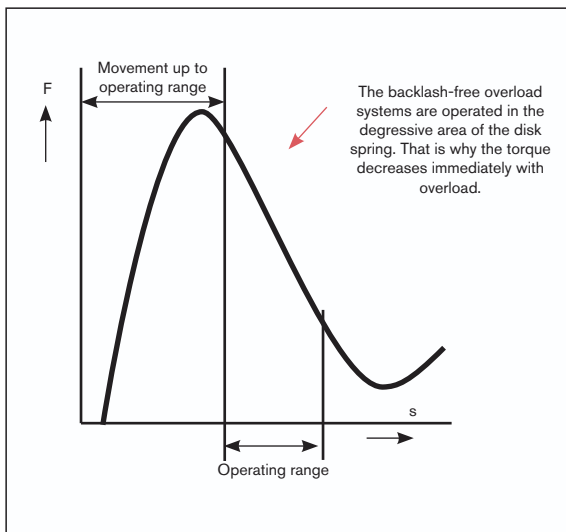

What does backlash-free mean?

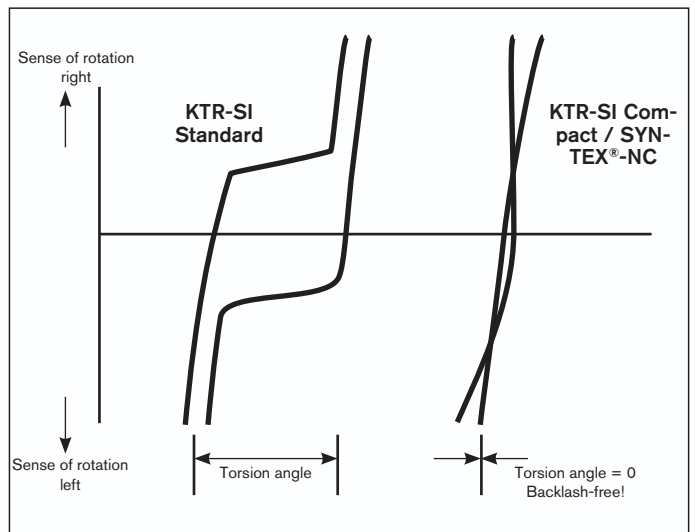

### Ratchet design DK

Any engagement after an overload. After eliminating the overload, the balls automatically re-engage with the next following ball indentation.

### Synchronous design SK

Synchronous engagement after an overload. After eliminating the overload, the balls re-engage automatically with the disk springs after a rotation of 360°. Driving and driven side are always placed in the same position to each other. Other degrees of re-engagement, for example 180°, are also possible.

● = The core of the backlash-free overload systems

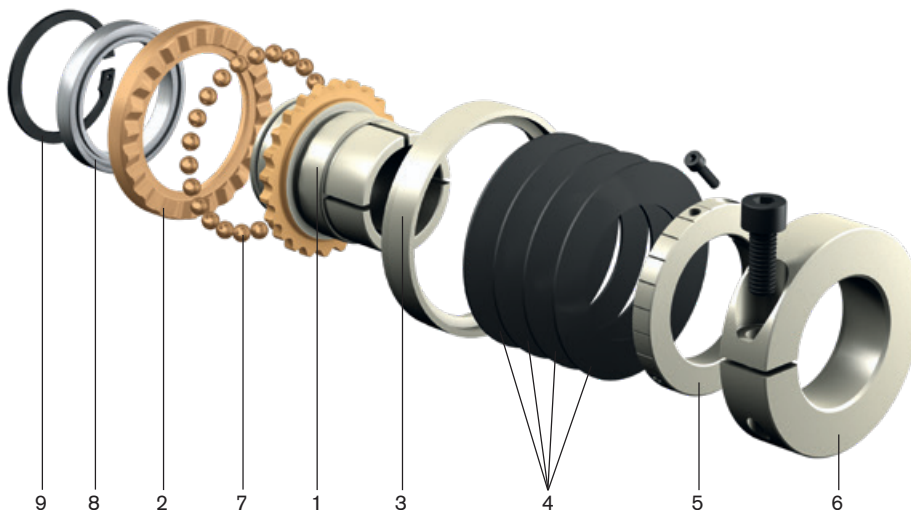

#### List of components:

1. Hub with keyway to DIN (type 1.0) or with clamping ring (type 6.1)
2. Flange ring
3. Shifting ring
4. Disk spring
5. Setting nut
6. Clamping ring
7. Balls
8. Groove ball bearing
9. Circlip

# SYNTEX®-NC / KTR-SI Compact Backlash-free overload systems

## Operating principle

### SYNTEX®-NC

- Overload protection up to 550 Nm
- Backlash-free torque transmission
- Light-weight design
- Degressive spring characteristic curve
- Low mass moment of inertia
- Large bore diameters
- Short response times
- High power density

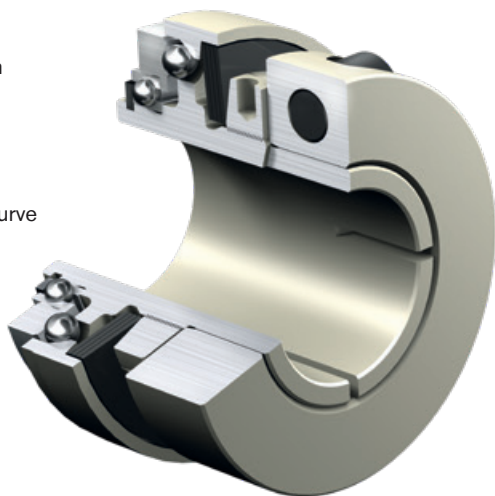

- Clamping ring design easy to assemble
- Available both as a ratchet (DK) and synchronous design (SK)
- Backlash-free shaft-hub-connection
- In combination with the backlash-free, torsionally flexible ROTEX® GS or backlash-free, torsionally stiff TOOLFLEX®
- Direct assembly of toothed belt pulleys, as an example, possible (integrated groove ball bearing)

### KTR-SI Compact

- Overload protection up to 3,100 Nm
- Backlash-free overload system with a degressive spring characteristic curve
- Solid design
- Accurate disengagement with high repeatability
- Accurate backlash-free torque transmission even in case of wear
- Shifting ring with setting scale for accurate torque setting



- Easy torque setting by torque scale on the coupling
- Connection flange with ball bearing
- Hardened ratchet surfaces for a long service life
- Backlash-free shaft-hub-connection via taper bush
- Can be used with the proven ROTEX® GS as a shaft-to-shaft connection

RU FLEX®

KTR-SI

SYNTEX®

SYNTEX®-NC

KTR-SI Compact

Torque  
limiters

# SYNTEX®-NC

## Backlash-free overload systems

### Hub type



For legend of pictogram refer to flapper on the cover



Hub type 1.0 (keyway acc. to DIN 6885)

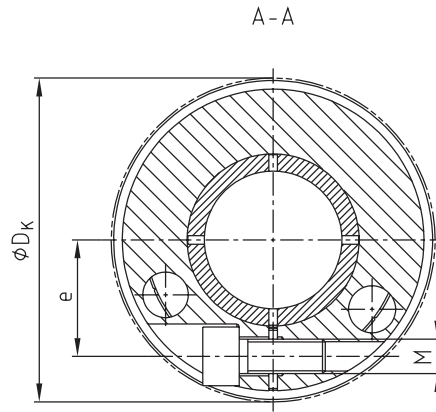
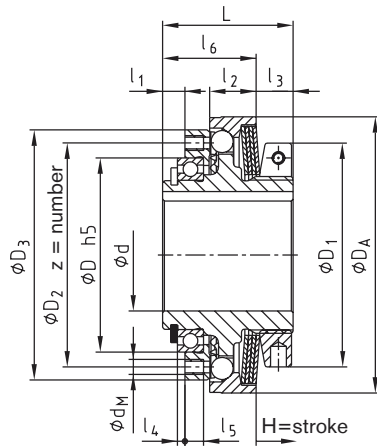

Hub type 6.1 (clamping ring)

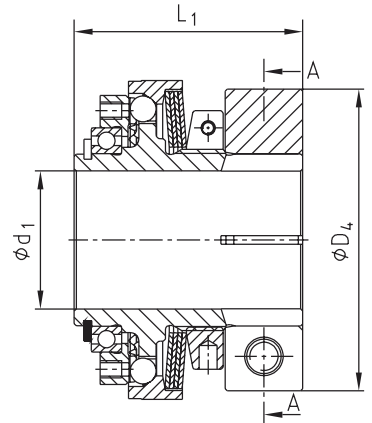

#### Technical data – dimensions

Size	Max. speed <sup>3)</sup> [rpm]	Torques [Nm]			Max. bore d	Dimensions [mm]											L	z x d <sub>M</sub>	H=stroke
		T1	T2	T3		D <sub>h5</sub>	D <sub>1</sub>	D <sub>2</sub>	D <sub>3</sub>	D <sub>A</sub>	I1	I2	I3	I4	I5	I6			
15	3500	2-3.5	3.5-7	7-14	12	32	33	37	42	42	5.0	7.0	9.2	2	4	18.8	28	12xM3	0.8
25	3000	9-15	20-35	40-65	20 (22) <sup>1)</sup>	42	50	48	56	61	5.5	11.5	9.1	2	5	23.9	33	8xM4	1.2
32	3000	25-38	50-75	100-150	27 (30) <sup>1)</sup>	52	60	60	67	74	6	12.5	9.9	2	5	25.1	35	8xM4	1.5
42	2500	30-65	60-135	120-265	36 (38) <sup>1)</sup>	65	72	75	83	90	7	16	11.2	2	6	31.8	43	8xM5	1.5
60 <sup>4)</sup>	2000	70-140	120-180	220-550	50	90	96	100	113	116	8	21	11.8	2	7	38.2	52	12xM6	1.8

#### Dimensions – Hub type 6.1

Size	Bore d <sub>1</sub>		Dimensions [mm]						Weight with max. bore [kg]	Mass moment of inertia <sup>2)</sup> J <sub>total</sub> [kgm <sup>2</sup> ]
	Pilot bore	max.	D <sub>4</sub>	DK	L <sub>1</sub>	e	M	T <sub>A</sub> [Nm]		
15	7.5	15	40	43	38	15	M4	1.7	0.124	0.029 x 10 <sup>-3</sup>
25	9.5	25	55	-	45	21	M6	14	0.282	0.14 x 10 <sup>-3</sup>
32	13.5	32	70	-	53	27	M8	34	0.471	0.35 x 10 <sup>-3</sup>
42	18.5	42	86	91.2	63	33	M10	67	0.815	0.95 x 10 <sup>-3</sup>
60 <sup>4)</sup>	24	60	112	119.4	75	45	M12	115	3.04	5.9 x 10 <sup>-3</sup>

#### Transmittable friction torques T<sub>R</sub> [Nm] (clearance H7/h6) of hub type 6.1

Size	Ø8	Ø10	Ø11	Ø12	Ø14	Ø15	Ø16	Ø18	Ø19	Ø20	Ø22	Ø24	Ø25	Ø28	Ø30	Ø32	Ø35	Ø36	Ø38	Ø40	Ø42	Ø45	Ø48	Ø50	Ø55	Ø60
15	8	12	14	16	22	24																				
25		30	35	42	55	62	69	48	53	58	69	80	86													
32						74	83	104	114	125	148	116	125	153	172	192										
42										149	178	209	225	275	310	264	309	324	356	389	422					
60 <sup>4)</sup>													247	310	356	405	485	513	571	633	394	452	514	558	675	803

<sup>1)</sup> The figure in brackets specifies the max. bore with keyway to DIN 6885 sheet 3 (low-rise design)

<sup>2)</sup> With max. bore

<sup>3)</sup> See comments on page 265

<sup>4)</sup> Material steel

Ordering example:

SYNTEX®-NC 32	SK	6.1	T3	d <sub>1</sub> Ø25	120
Type/size	Type (DK/SK)	Hub type	Disk springs	Bore	Torque set

# SYNTEX®-NC

## Backlash-free overload systems

With backlash-free ROTEX® GS

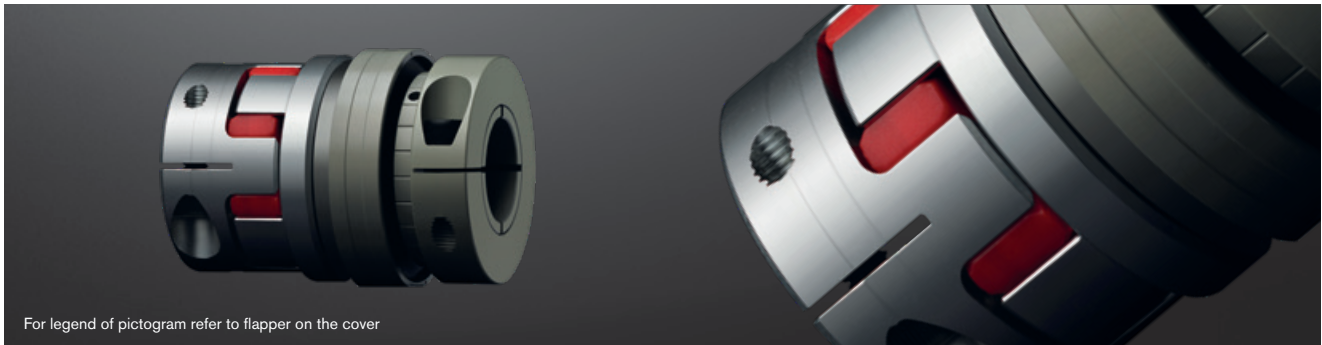

For legend of pictogram refer to flapper on the cover



LG1 = Hub type 2.8 from size 60 6.0 light  
LG2 = Hub type 2.5/2.6

Hub type 6.1

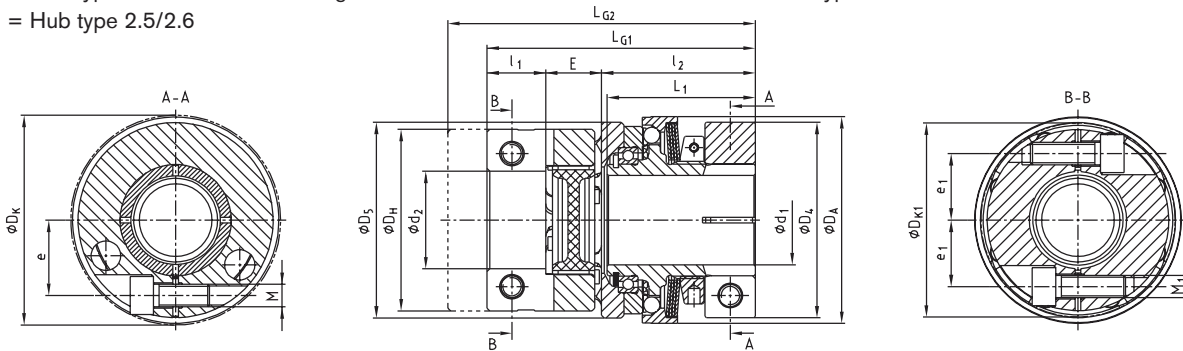

LG = Hub type 2.9 from size 60 1.0  
LG3 = Hub type 2.5/2.6

Hub type 1.0

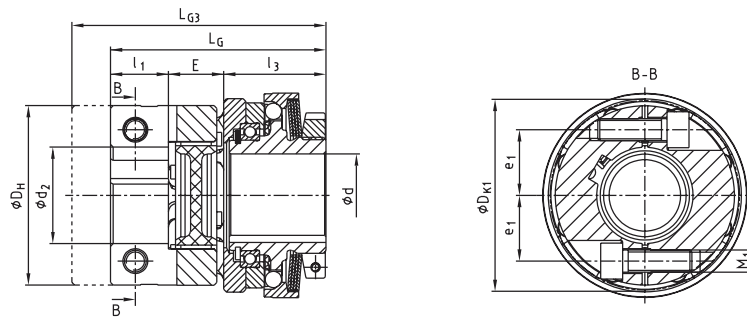

### Technical data – dimensions

Size	ROTEX® GS size <sup>1)</sup>	Torques [Nm]			Max. speed <sup>2)</sup> [rpm]	Max. bore			Dimensions [mm]																			
		T1	T2	T3		d	d <sub>1</sub>	d <sub>2</sub>	D <sub>5</sub>	D <sub>H</sub>	DK	DK <sub>1</sub>	D <sub>A</sub>	l <sub>1</sub>	l <sub>2</sub>	l <sub>3</sub>	E	e	e <sub>1</sub>	L <sub>G</sub>	L <sub>1</sub>	L <sub>G1</sub>	L <sub>G2</sub>	L <sub>G3</sub>	M	T <sub>A</sub> [Nm]	M 1	T <sub>A1</sub> [Nm]
15	19	2-3.5	3.5-7	7-14	3500	12	15	24 <sup>3)</sup>	45	40	-	46.7	42	17	40	30	16	15	15.5	63	38	73	81	71	M4	1.7	M5	6
25	24	9-15	20-35	40-65	3000	20 (22) <sup>4)</sup>	25	32 <sup>3)</sup>	58	55	-	57.5	61	18	47.5	35.5	18	21	20	71.5	45	83.5	95.5	83.5	M6	14	M6	10
32	28	25-38	50-75	100-150	3000	27 (30) <sup>4)</sup>	32	35 <sup>3)</sup>	70	65	-	69	74	21	55	37	20	27	23.8	78	53	96	110	92	M8	34	M8	25
42	38	30-65	60-135	120-265	2500	36 (38) <sup>4)</sup>	42	45 <sup>3)</sup>	88	80	91.2	86	90	26	66	46	24	33	30.5	96	63	116	135	115	M10	67	M10	49
60 <sup>5)</sup>	48	70-140	120-280	220-550	2000	50	60	55 <sup>3)</sup>	113	105	119.4	-	116	56	83	60	28	45	-	144	75	167	144	M12	115	M10	49	

### Transmittable friction torques T<sub>R</sub> [Nm] (clearance H7/h6) of hub type 6.1

Size	Ø8	Ø10	Ø11	Ø12	Ø14	Ø15	Ø16	Ø18	Ø19	Ø20	Ø22	Ø24	Ø25	Ø28	Ø30	Ø32	Ø35	Ø36	Ø38	Ø40	Ø42	Ø45	Ø48	Ø50	Ø55	Ø60
15	8	12	14	16	22	24																				
25		30	35	42	55	62	69	48	53	58	69	80	86													
32					74	83	104	114	125	148	116	125	153	172	192											
42								149	178	209	225	275	310	264	309	324	356	389	422							
60 <sup>5)</sup>											247	310	356	405	485	513	571	633	394	452	514	558	675	803		

<sup>1)</sup> See selection of ROTEX® GS couplings on page 22 et seqq.

<sup>2)</sup> See comments on page 265

<sup>3)</sup> For transmittable friction torques T<sub>R</sub> [Nm] of ROTEX® GS hub type 2.8 or 6.0 refer to mounting instructions of ROTEX® GS

<sup>4)</sup> The figure in brackets specifies the max. bore with keyway to DIN 6885 sheet 3 (low-rise design)

<sup>5)</sup> Material steel

Ordering example:	SYNTEX®-NC 32	SK	6.1	T3	d <sub>1</sub> Ø25	28	2.8	d <sub>2</sub> Ø20	120
	Type/size	Type	Hub type	Disk springs	SYNTEX®-NC bore	ROTEX® GS size	Hub type	ROTEX® GS bore	Torque set

# SYNTEX®-NC

## Backlash-free overload systems

With torsionally stiff TOOLFLEX® S

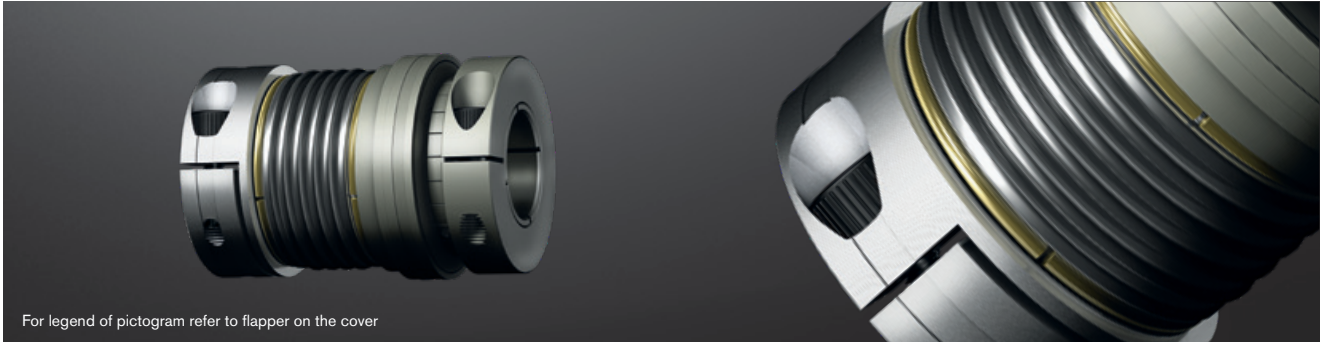

For legend of pictogram refer to flapper on the cover

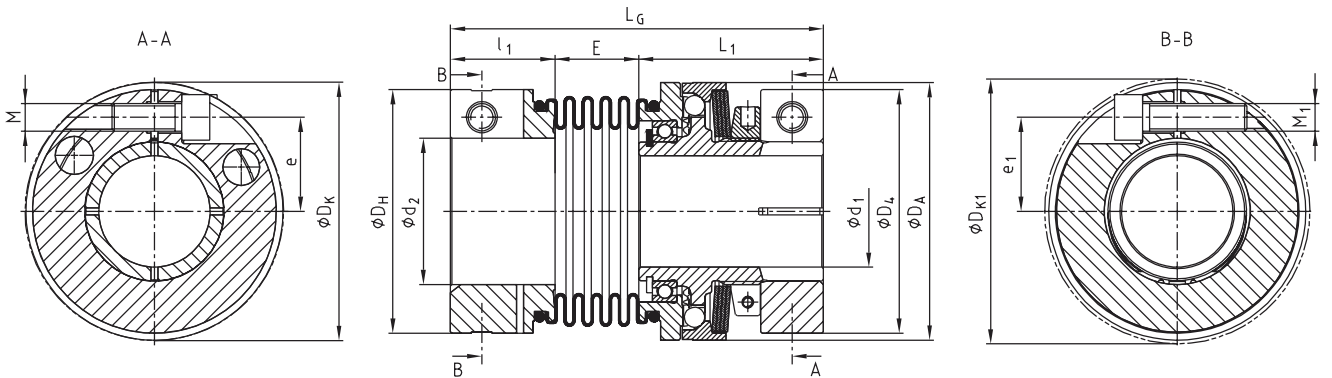

Technical data – dimensions																						
Size	TOOLFLEX® size <sup>1)</sup>	Torques [Nm]			Speed <sup>2)</sup> [rpm]	Max. bore		Dimensions [mm]														
		T1	T2	T3		d1	d2	D4	DH	DA	DK	DK1	l1	L1	E	e	e1	LG	M	TA [Nm]	M1	TA1 [Nm]
15	20	2-3.5	3.5-7	7-14	3500	15	20 <sup>3)</sup>	40	40	52	43	43.5	21.5	38	16.5	15	14.5	76	M4	1.7	M5	6
25	38	9-15	20-35	40-65	3000	25	38 <sup>3)</sup>	55	65	61	-	72.6	25.5	45	18	21	25	88	M6	14	M8	25
32	42	25-38	50-75	100-150	3000	32	42 <sup>3)</sup>	70	70	74	-	76.1	30	53	24	27	27	107	M8	34	M8	25
42	45	30-65	60-135	120-265	2500	42	45 <sup>3)</sup>	86	83	90	91.2	89	32	63	22.5	33	30	114	M10	67	M10	49
60 <sup>4)</sup>	65	70-140	120-280	220-550	2000	60	65 <sup>3)</sup>	112	125	140	119.4	127.1	45	84	36	45	45	165	M12	115	M14	185

Transmittable friction torques $T_R$ [Nm] (clearance H7/h6) of hub type 6.1																										
Size	Ø8	Ø10	Ø11	Ø12	Ø14	Ø15	Ø16	Ø18	Ø19	Ø20	Ø22	Ø24	Ø25	Ø28	Ø30	Ø32	Ø35	Ø36	Ø38	Ø40	Ø42	Ø45	Ø48	Ø50	Ø55	Ø60
15	8	12	14	16	22	24																				
25		30	35	42	55	62	69	48	53	58	69	80	86													
32						74	83	104	114	125	148	116	125	153	172	192										
42										149	178	209	225	275	310	264	309	324	356	389	422					
60 <sup>4)</sup>													247	310	356	405	485	513	571	633	394	452	514	558	675	803

<sup>1)</sup> See selection of TOOLFLEX® couplings on page 22 et seqq.

<sup>2)</sup> See comments on page 265

<sup>3)</sup> For transmittable friction torques  $T_R$  [Nm] of TOOLFLEX® hub type 2.5 refer to mounting instructions of TOOLFLEX®

<sup>4)</sup> Material steel

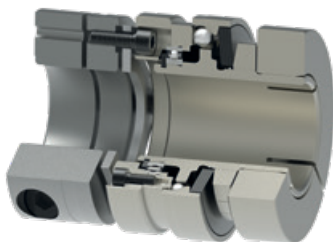

Special type:

- SYNTEX®-NC with RADEX®-NC

Ordering example:	SYNTEX®-NC 32	SK	6.1	T3	d1 Ø25	42-S	2.5	d2 Ø20	120
	Type/size	Type	Hub type	Disk springs	SYNTEX®-NC bore	TOOLFLEX® size	Hub type	TOOLFLEX® bore	Torque set

# KTR-SI Compact Backlash-free overload systems

RUFLEX®

## Flange type



For legend of pictogram refer to flapper on the cover



KTR-SI

### Hub type 1.0

### Hub type 4.5 with taper sleeve

Size 01 - 3

Size 4

Size 01 - 3

Size 4

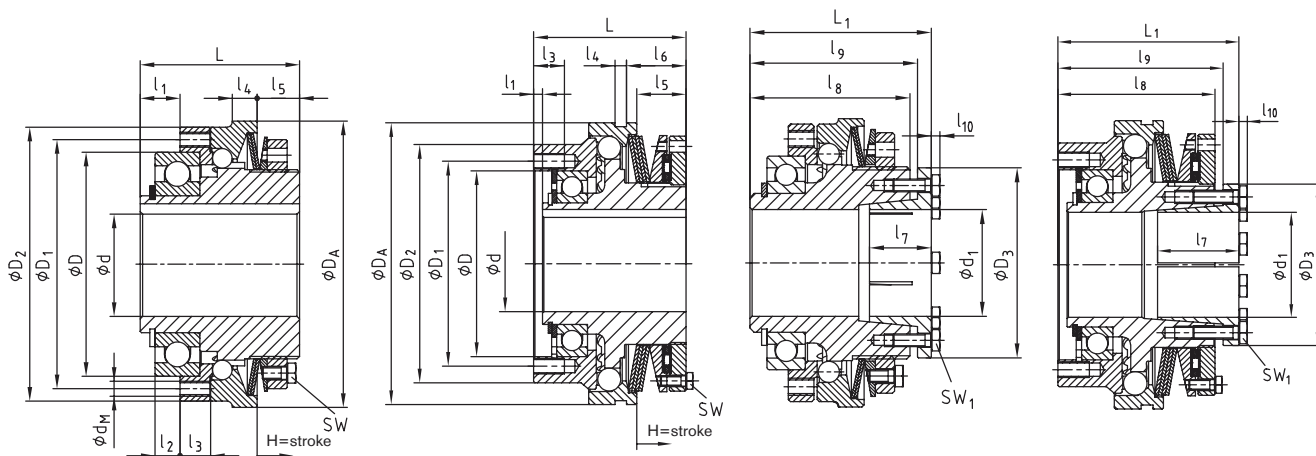

SYNTEX®

### Technical data – dimensions

Size	Speed <sup>1)</sup> [rpm]	Torque [Nm]			Dimensions [mm]														
		T1	T2	T3	Bore d	D <sub>h5</sub>	D <sub>1</sub>	D <sub>2</sub>	D <sub>A</sub>	l1	l2	l3	l4	l5	l6	L	d <sub>M</sub>	SW	H= stroke
01	4000	3-14	6-28	13-56	8-20	47	56	65	70	8	5	7.5	7	12	-	40	8xM4	7	1.2
0	3000	9-35	18-70	40-140	10-25 (30) <sup>3)</sup>	62	71	80	85	11	7	8.0	8	14	-	48	8xM5	7	1.5
1	2500	19-65	38-130	78-260	14-30 (35) <sup>3)</sup>	75	85	95	100	14	9	10.5	9	16	-	59	8xM6	8	1.8
2	2000	35-110	80-220	160-440	18-40 (45) <sup>3)</sup>	90	100	110	115	16	10	12	10	17	-	64	8xM6	10	2.0
3	1200	80-200	160-400	320-800	24-50	100	116	130	135	18	10	12	12	21	-	75	8xM8	10	2.2
4	400	230-730	460-1590	960-3100	40-75	145 <sup>H7</sup>	160	186	220	7	-	24	9	38.5	46.5	119	6xM12	13	3.5

### Dimensions – Hub type 4.5

Size	Bore <sup>2)</sup>		Dimensions [mm]							SW <sub>1</sub>	T <sub>A</sub> [Nm]
	d <sub>1</sub>	D <sub>3</sub>	l7	l8	l9	l10	L <sub>1</sub>				
01	10-20	40.5	26	40	42	2.8	47	7	3		
	19-25	42									
0	15-20	40.5	26	46	48	2.8	53	7	4.6		
	19-30	57									
1	19-30	57	40	57	60	4	67	10	10		
	32-40	64									
2	32-50	73.5	29	63	66.5	4	73	10	10		
	32-50	73.5									
3	55-60	89	44	75	78	4	86	10	10		
	55-60	89									
4	50-60	96.5	54	119	125.5	5.5	133.5	13	28		
	65-80	123									

<sup>1)</sup> See comments on page 265

<sup>2)</sup> For transmittable friction torques T<sub>R</sub> [Nm] of hub type 4.5 refer to assembly instructions

<sup>3)</sup> The figure in brackets specifies the max. bore with keyway to DIN 6885 sheet 3 (low-rise design)

### Ordering example:

KTR-SI Compact 2	DK	4.5	T2	d <sub>1</sub> Ø40	150 Nm
Type/size	Type (DK/SK)	Hub type	Disk springs	Bore	Torque set

SYNTEX®-NC

Torque limiters

KTR-SI Compact

# KTR-SI Compact

## Backlash-free overload systems

With backlash-free ROTEX® GS

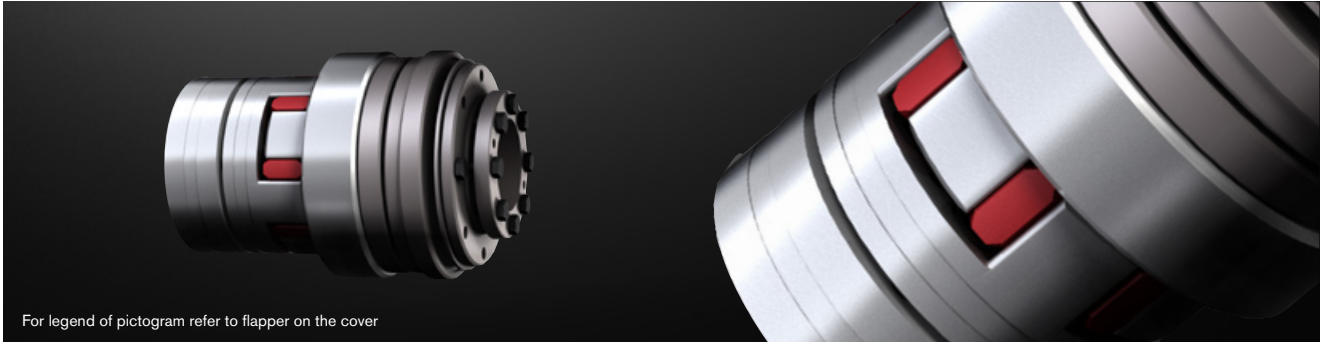

For legend of pictogram refer to flapper on the cover



Hub type 1.0

Hub type 1.0

Hub type 6.0

Hub type 4.5

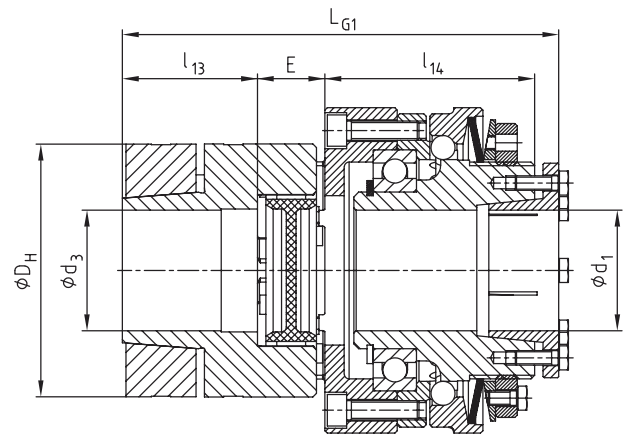
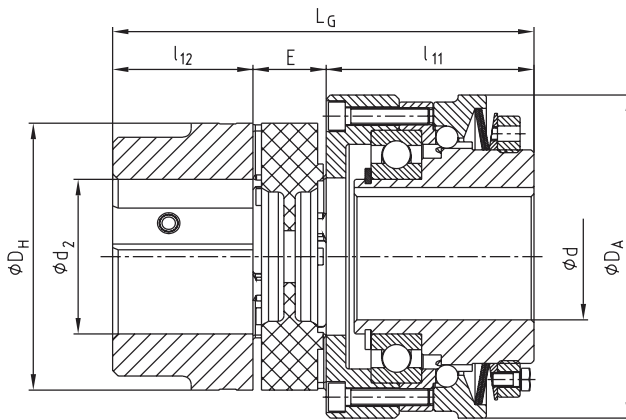

### Technical data – dimensions

Size	Max. speed <sup>1)</sup> [rpm]	Torques [Nm]			ROTEX® GS size <sup>2)</sup>	Max. bore				Dimensions [mm]								
		T1	T2	T3		d	d <sub>1</sub>	d <sub>2</sub>	d <sub>3</sub>	DH	D <sub>A</sub>	l <sub>11</sub>	l <sub>12</sub>	l <sub>13</sub>	l <sub>14</sub>	E	L <sub>G</sub>	L <sub>G1</sub>
01	4000	3-14	6-28	13-56	24	20	25	28	20	55	70	47	30	30	47	18	95	102
0	3000	9-35	18-70	40-140	28	25	30	38	38	65	85	56.5	35	35	54.5	20	111.5	119.5
1	2500	19-65	38-130	78-260	38	30	40	45	48	80	100	69	45	45	67	24	138	146
2	2000	35-110	80-220	160-440	42	40 (45) <sup>3)</sup>	50	55	51	95	115	74	50	50	73	26	150	159
3	1200	80-210	160-400	320-800	48	50	60	62	55	105	135	87	56	56	87	28	171	182
4	400	230-730	460-1590	960-3100	75	75	80	80	80	160	220	158.5	85	85	139.5	40	283.5	302.5

<sup>1)</sup> See comments on page 265

<sup>2)</sup> See selection of ROTEX® GS couplings on page 22 et seqq.

<sup>3)</sup> The figure in brackets specifies the max. bore with keyway to DIN 6885 sheet 3 (low-rise design)

Ordering  
example:

KTR-SI Compact 1	DK	T2	4.5	d <sub>1</sub> Ø25	6.0 / d <sub>3</sub> Ø25	150 Nm
Type/size	Type (DK/SK)	Disk spring	KTR-SI hub type	KTR-SI bore	ROTEX® GS hub type/bore	Torque set





# Clamping elements and precision joints

## CLAMPEX®

Types of clamping elements 294

Selection 296

Selection guide 298

Calculation of hubs 299

KTR 100 310

KTR 105 302

KTR 130 and KTR 131 304

KTR 150 306

KTR 200 and KTR 201 308

KTR 203 and KTR 206 310

KTR 225 312

KTR 250 314

KTR 400 316

KTR 603 318

KTR 620 322

KTR 700 326

## KTR Clamping nuts

Large screw connections 328

for easy and quick assembly

## KTR Precision joints

Series and selection criteria 330

Instructions for correct assembly 331

Selection and sizing 332

Type G and GD with plain bearing 334

Type H and HD with needle bearing 335

Type GA and HA plain and needle bearing 336

(extendable) 337

Type X and XD with plain bearing 337

made of stainless steel

Type GR and HR with quick locking 338

Accessories (protection bushings) 339

Internal clamping elements



External clamping elements



Shaft couplings

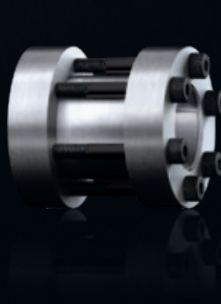

Precision joints

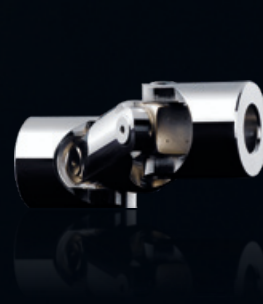

# CLAMPEX® CLAMPING ELEMENTS

## TYPES AND OPERATING DESCRIPTION

### Properties of clamping elements

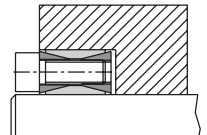
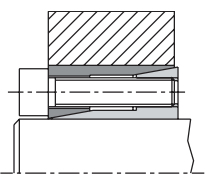
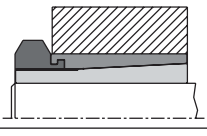
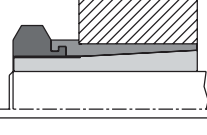
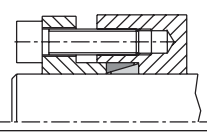
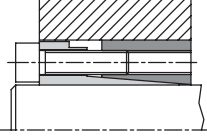
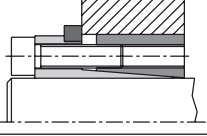
Type	Series	Shaft diameter [mm]	Transmittable torque T [Nm]	Centering of hub to shaft via the clamping element	Centering between hub and shaft required	Axial displacement of hub during assembly of clamping element	Details on page
Internal clamping elements	 KTR 100	17 – 1,000	260 – 3,017,100		●		308 309
	 KTR 105	5 – 50	5 – 1,900	●		●	310 311
	 KTR 130	5 – 50	10 – 2,320	●		●	312 313
	 KTR 131	5 – 35	10 – 836	●		●	312 313
	 KTR 150	6 – 440	2 – 215,000		●	●*	314 315
	 KTR 200	20 – 200	530 – 68,000	●		●	316 317
	 KTR 201	20 – 200	320 – 48,800	●			316 317

\* Depending on mounting position

# CLAMPEX® CLAMPING ELEMENTS

## TYPES AND OPERATING DESCRIPTION

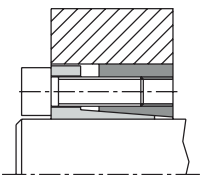
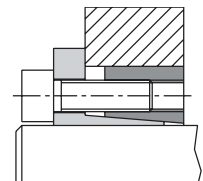
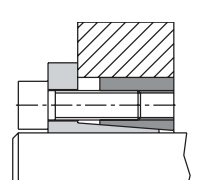
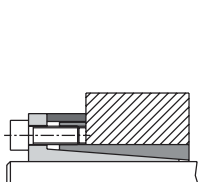
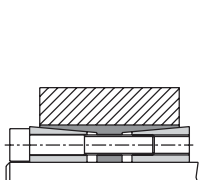
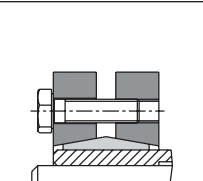
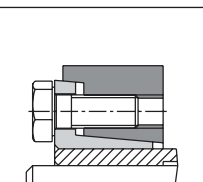
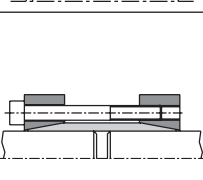
Type	Series	Shaft diameter [mm]	Transmittable torque T [Nm]	Centering of hub to shaft via the clamping element	Centering between hub and shaft required	Axial displacement of hub during assembly of clamping element	Details on page
Internal clamping elements	 KTR 203	18 – 400	370 – 487,000	●		●	318 319
	 KTR 206	18 – 400	290 – 342,000	●			318 319
	 KTR 225	14 – 50	287 – 1,796	●			320 321
	 KTR 250	6 – 130	11 – 25,000	●			322 323
	 KTR 400	24 – 600	700 – 1,640,000	●		●	324 325
External clamping elements	 KTR 603	10 – 420	28 – 1,460,000	●			326 - 329
	 KTR 620	13 – 700	70 – 7,394,000	●			330 - 333
Shaft couplings	 KTR 700	10 – 100	62 – 8,350	●			334 335

CLAMPEX®

Clamping nuts

KTR Precision joints

Clamping sets

### Guide for selection

#### 1. Which properties of a clamping set are required?

- Shall shaft and hub be centered to each other by the clamping set?
- Is axial displacement of the hub permissible during assembly of the clamping set?

For an explanation of the properties specified above see CLAMPEX® selection guide on page 306.

#### 2. Which dimensions of clamping sets are required?

- Internal diameter of clamping set
- External diameter of clamping set
- Length of clamping set

For dimensions of clamping sets see catalogue on page 309 et seqq.

#### 3. How much torque and/or axial force needs to be transmitted?

The following safety factors are recommended by KTR:

- ≥ 1.5 between the maximum torque of machine and the transmittable torque of clamping set.
- ≥ 2.0 between the rated torque of machine and the transmittable torque of clamping set.

#### 4. Are shaft and hub suitable for the clamping set connection?

Calculation of the components is possible via the following methods:

- Formula for calculation of components see page 297.
- Review of components as well as the entire application via KTR CLAMPEX® online tool at [www.KTR.com](http://www.KTR.com).

#### 5. Other selection criteria

For questions about the following subjects, please contact the KTR engineering department.

- The clamping set is to be mounted on a shaft with a feather keyway.
- Simultaneous transmission of torque and axial force.
- The clamping set is radially loaded.
- The clamping set is loaded on bending.
- High circumferential speeds (from 30 m/s).
- Low/high operating temperatures (below -20 °C or above +50 °C).
- Shaft with bore (hollow shaft).
- Clamping set in a corrosion-protected design.
- Use in potentially explosive atmosphere (ATEX).
- Concentricity and axial run-out accuracies.
- Notch impact factors.

Table of screws						
Dimension M	Preload force $F_V$ and tightening torque $T_A$ with $\mu_{total} = 0.14$					
	Preload force $F_V$ [N]			Tightening torque $T_A$ [Nm]		
	8.8	10.9	12.9	8.8	10.9	12.9
M3	2210	3110	3730	1.34	1.89	2.25
M4	3900	5450	6550	2.9	4.1	4.9
M5	6350	8950	10700	6	8.5	10
M6	9000	12600	15100	10	14	17
M8	16500	23200	27900	25	35	41
M10	26200	36900	44300	49	69	83
M12	38300	54000	64500	86	120	145
M14	52500	74000	88500	135	190	230
M16	73000	102000	123000	210	295	355
M18	88000	124000	148000	290	405	485
M20	114000	160000	192000	410	580	690
M22	141000	199000	239000	550	780	930
M24	164000	230000	276000	710	1000	1200
M27	215000	302000	363000	1050	1500	1800
M30	262000	368000	442000	1450	2000	2400

### Selection

Symbol	Definition resp. explanation
$\sigma_{N0.2}$	Yield point of hub material [N/mm <sup>2</sup> ]
$\sigma_{W0.2}$	Yield point of shaft material [N/mm <sup>2</sup> ]
C	Specific heat capacity C of hub type (see illustration on page 323)
d	Internal diameter of clamping element [mm]
$d_{iW}$	Internal diameter of hollow shaft [mm]
D	External diameter of clamping element [mm]
$D_N$	Required external diameter of hub [mm]
T	Transmittable torque [Nm]
$T_S$	Peak torque to be transmitted [Nm]
$T_A$	Screw tightening torque [Nm]
B2/B3	Length of clamping element [mm]

Symbol	Definition resp. explanation
L/L <sub>1</sub>	Hub length [mm]
$P_N$	Surface pressure generated on the clamping element/hub [N/mm <sup>2</sup> ]
$P_W$	Surface pressure generated on the clamping element/shaft [N/mm <sup>2</sup> ]
$C_W$	$d_{iW}/d$ -> Ratio of internal diameter of hollow shaft/clamping element
$C_N$	$D/D_N$ -> Ratio of external diameter of clamping element/hub
$F_a$	Axial force generated during operation [kN]
$F_{ax}$	Transmittable axial force [kN]
$F_V$	Preload force [N]
$P_O$	Setting force for clamping element [N]
$P_S$	Clamping force for clamping element [N]
$P_A$	$P_O + P_S$ = Total force for clamping element [N]

The transmission data are parameters found out by calculations. Subject to the friction coefficient variation which is subjected to physical properties, small deviations with the transmission figures may arise.

#### 1. Fatigue strength and shape stability of components subjected to torsion and bending load

The stress concentration figures  $\beta_k$  for the clamping elements press fits are worked out similarly to those of pressure oil fits. Stress concentration factors on request.

#### 2. Transmittable torque T

The transmittable torque T always has to be above the biggest torque peak  $T_S$ , which may arise on the joints. The torque peaks occurring with acceleration of electric motors as well as additional axial forces  $F_a$  have to be considered.

$$T \geq \sqrt{T_S^2 + (F_a \cdot \frac{d}{2})^2}$$

#### 3. Transmittable axial force $F_{ax}$

The maximum transmittable axial force  $F_{ax}$  specified in the tables has to be reduced accordingly with additional torque transmission.

$$F_{ax} [kN] = 2 \cdot \frac{T [Nm]}{d [mm]}$$

#### 4. Calculation of external diameter of hub $D_N$

The required external diameter of hub  $D_N$  depends on the hub geometry, the yield point of the hub material and the surface pressure between clamping element and hub. In order to simplify the calculation, the table on page 323 specifies correction values which allow to calculate  $D_N$ .

$$D_N [mm] \geq D \cdot \text{correction value } x$$

Those external diameters of hubs which cannot be calculated based on the table are calculated via the following formula:

$$D_N \geq D \cdot \sqrt{\frac{\sigma_{N0.2} + P_N \cdot C}{\sigma_{N0.2} - P_N \cdot C}}$$

Tangential stress on the internal diameter of hub

$$\sigma_{tiN} \approx P_N \cdot \frac{(1 + C_N^2)}{(1 - C_N^2)} \cdot C$$

For clamping connections with hollow shafts the required internal diameter of the hollow shaft  $d_{iW}$  is calculated based on the following formula:

$$d_{iW} \leq d \cdot \sqrt{\frac{\sigma_{W0.2} - 2 \cdot P_W \cdot 0.8}{\sigma_{W0.2}}}$$

Tangential stress on the internal diameter of shaft

$$\sigma_{tiW} \approx \frac{2 \cdot P_W}{(C_W^2 - 1)}$$

#### Selection of shaft and hub material with external clamping sets KTR 603 and KTR 620

The shaft and hub material should have a yield strength  $Re$  of  $\geq 350$  N/mm<sup>2</sup>. For applications with additional bending load, Q + T steel such as 42CrMo4 should be used.

### Selection guide

### Selection guide for CLAMPEX® clamping elements

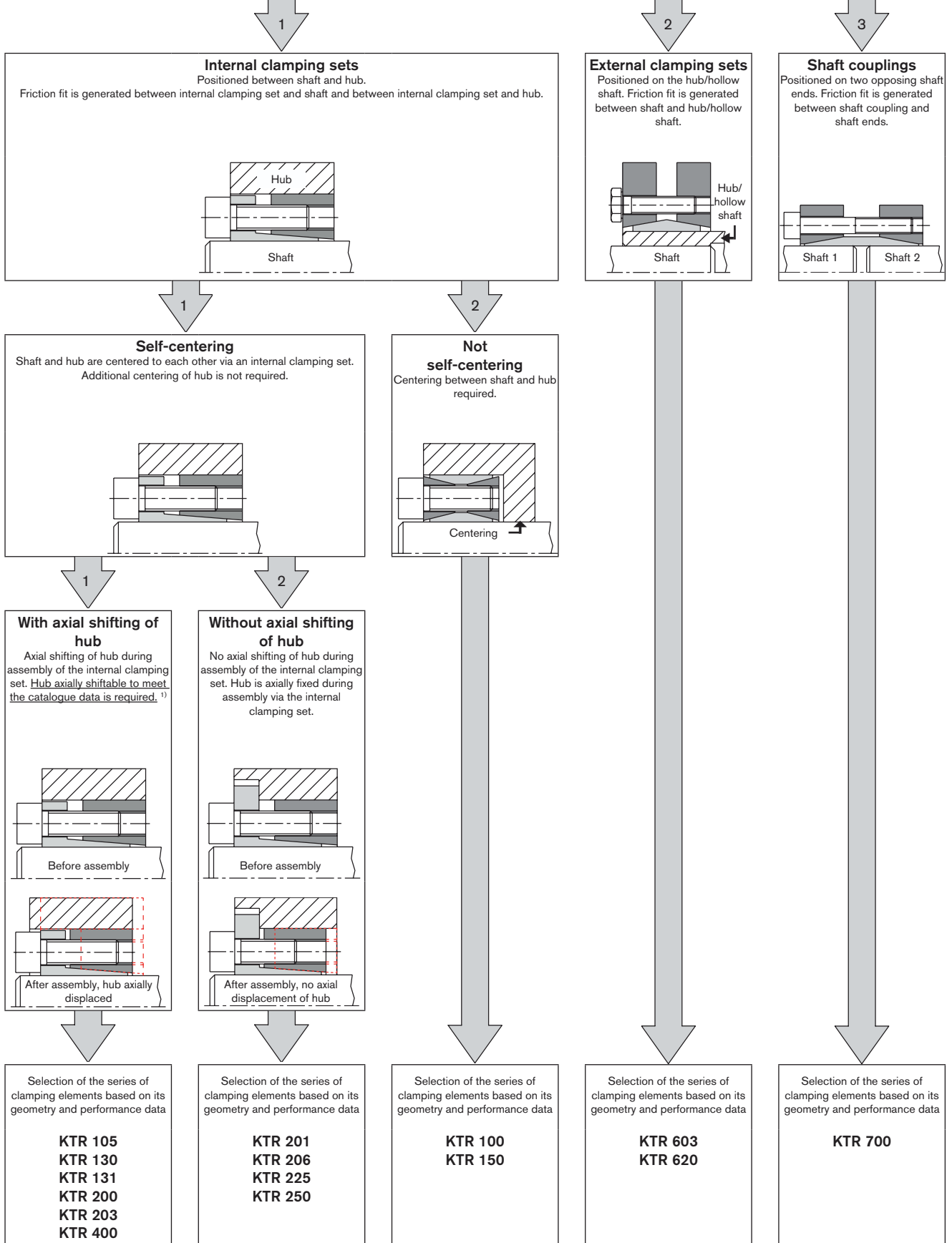

<sup>1)</sup> Does not apply for KTR 400

### Calculation of hubs

Mounting conditions of clamping elements with specific heat capacity C of hub type

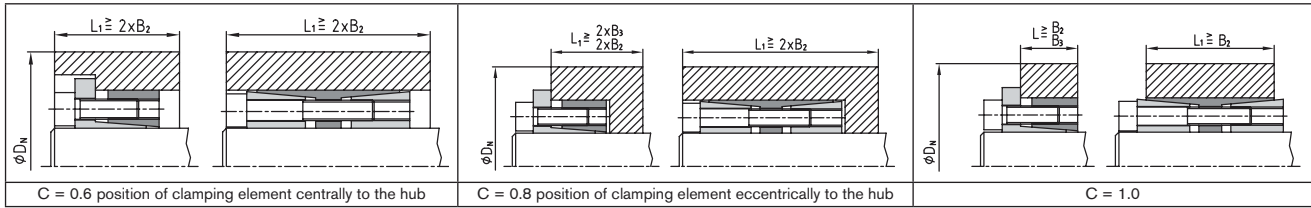

C = 0.6 position of clamping element centrally to the hub

C = 0.8 position of clamping element eccentrically to the hub

C = 1.0

Selection table for the calculation of the external diameter of hub  $D_N$  required (correction value x)

Surface pressure between clamping element and hub		Average yield point of material $\sigma \geq 0.2$ in N/mm <sup>2</sup> (more accurate stiffness figures depending on diameter as specified by the manufacturer)										
		150	180	200	220	250	270	300	350	400	450	600
		Hub materials										
$P_N$ [N/mm <sup>2</sup> ]	Specific heat capacity C of hub type	GJL 200	GJL 250 GE 200	GJL 300 GJMB-350	GE 240	GJS 400-15 GE 260 AW-2007	E295 C 35	GJS 500-7 GE 300 S355J2	GJS 600-3 C 45	GJS 700-2 C 60	Q & T steel	Q & T steel
65	C = 0.6	1.30	1.25	1.22	1.20	1.18	1.15	1.13	1.11	1.10	1.09	1.07
	C = 0.8	1.44	1.35	1.30	1.28	1.24	1.22	1.20	1.16	1.14	1.12	1.09
	C = 1.0	1.60	1.45	1.40	1.35	1.30	1.28	1.24	1.20	1.18	1.16	1.12
70	C = 0.6	1.34	1.26	1.24	1.22	1.18	1.16	1.15	1.12	1.11	1.10	1.07
	C = 0.8	1.48	1.38	1.34	1.30	1.25	1.23	1.20	1.18	1.15	1.13	1.10
	C = 1.0	1.65	1.50	1.45	1.40	1.34	1.30	1.26	1.22	1.20	1.17	1.13
75	C = 0.6	1.30	1.28	1.25	1.23	1.20	1.18	1.16	1.14	1.12	1.11	1.08
	C = 0.8	1.52	1.42	1.36	1.32	1.28	1.25	1.22	1.18	1.16	1.14	1.11
	C = 1.0	1.74	1.55	1.48	1.42	1.36	1.33	1.30	1.25	1.20	1.18	1.13
80	C = 0.6	1.39	1.31	1.28	1.25	1.21	1.20	1.18	1.15	1.13	1.11	1.08
	C = 0.8	1.58	1.45	1.39	1.35	1.30	1.27	1.24	1.20	1.18	1.15	1.11
	C = 1.0	1.81	1.61	1.53	1.46	1.39	1.36	1.31	1.26	1.22	1.20	1.14
85	C = 0.6	1.42	1.34	1.30	1.27	1.23	1.21	1.19	1.16	1.14	1.12	1.09
	C = 0.8	1.63	1.49	1.42	1.38	1.32	1.29	1.26	1.22	1.19	1.16	1.12
	C = 1.0	1.90	1.67	1.57	1.50	1.42	1.39	1.34	1.28	1.24	1.21	1.15
90	C = 0.6	1.46	1.36	1.32	1.28	1.25	1.22	1.20	1.17	1.15	1.13	1.09
	C = 0.8	1.69	1.53	1.46	1.40	1.34	1.31	1.28	1.23	1.20	1.18	1.13
	C = 1.0	2.00	1.73	1.62	1.54	1.46	1.41	1.36	1.30	1.26	1.22	1.16
95	C = 0.6	1.49	1.39	1.34	1.30	1.26	1.24	1.21	1.18	1.15	1.14	1.10
	C = 0.8	1.75	1.57	1.49	1.43	1.37	1.34	1.30	1.25	1.21	1.19	1.14
	C = 1.0	2.11	1.80	1.68	1.59	1.49	1.44	1.39	1.32	1.27	1.24	1.17
100	C = 0.6	1.53	1.41	1.36	1.32	1.28	1.25	1.22	1.19	1.16	1.14	1.11
	C = 0.8	1.81	1.61	1.53	1.46	1.39	1.36	1.31	1.26	1.22	1.20	1.14
	C = 1.0	2.24	1.87	1.73	1.63	1.53	1.48	1.41	1.34	1.29	1.25	1.18
105	C = 0.6	1.56	1.44	1.39	1.34	1.29	1.27	1.24	1.20	1.17	1.15	1.11
	C = 0.8	1.88	1.66	1.56	1.50	1.42	1.38	1.33	1.28	1.24	1.21	1.15
	C = 1.0	2.38	1.95	1.79	1.68	1.56	1.51	1.44	1.36	1.31	1.27	1.19
110	C = 0.6	1.60	1.47	1.41	1.36	1.31	1.28	1.25	1.21	1.18	1.16	1.12
	C = 0.8	1.96	1.71	1.60	1.53	1.44	1.40	1.35	1.29	1.25	1.22	1.16
	C = 1.0	2.55	2.04	1.86	1.73	1.60	1.54	1.47	1.38	1.33	1.28	1.20
115	C = 0.6	1.64	1.50	1.43	1.36	1.33	1.30	1.26	1.22	1.19	1.17	1.12
	C = 0.8	2.04	1.76	1.64	1.56	1.47	1.43	1.37	1.31	1.26	1.23	1.17
	C = 1.0	2.75	2.13	1.93	1.79	1.64	1.58	1.50	1.41	1.34	1.30	1.21
120	C = 0.6	1.69	1.53	1.46	1.40	1.34	1.31	1.28	1.23	1.20	1.18	1.13
	C = 0.8	2.13	1.81	1.69	1.60	1.50	1.45	1.39	1.33	1.28	1.24	1.18
	C = 1.0	3.00	2.24	2.00	1.84	1.69	1.61	1.53	1.43	1.36	1.31	1.22
125	C = 0.6	1.73	1.56	1.48	1.43	1.36	1.33	1.29	1.24	1.21	1.18	1.13
	C = 0.8	2.24	1.87	1.73	1.63	1.53	1.48	1.41	1.34	1.29	1.25	1.18
	C = 1.0	3.32	2.35	2.08	1.91	1.73	1.65	1.56	1.45	1.38	1.33	1.24
130	C = 0.6	1.78	1.59	1.51	1.45	1.38	1.35	1.30	1.25	1.22	1.19	1.14
	C = 0.8	2.35	1.93	1.78	1.67	1.56	1.50	1.44	1.36	1.30	1.27	1.19
	C = 1.0	3.74	2.49	2.17	1.97	1.78	1.69	1.59	1.48	1.40	1.35	1.25
135	C = 0.6	1.83	1.62	1.54	1.47	1.40	1.36	1.32	1.27	1.23	1.20	1.15
	C = 0.8	2.48	2.00	1.83	1.71	1.59	1.53	1.46	1.38	1.32	1.28	1.20
	C = 1.0	4.36	2.65	2.27	2.04	1.83	1.73	1.62	1.50	1.42	1.36	1.26
140	C = 0.6	1.88	1.66	1.56	1.50	1.42	1.38	1.33	1.28	1.24	1.21	1.15
	C = 0.8	2.63	2.07	1.88	1.75	1.62	1.55	1.48	1.39	1.33	1.29	1.21
	C = 1.0	5.39	2.83	2.38	2.12	1.88	1.78	1.66	1.53	1.44	1.38	1.27
145	C = 0.6	1.94	1.69	1.59	1.52	1.44	1.40	1.35	1.29	1.25	1.22	1.16
	C = 0.8	2.80	2.15	1.94	1.80	1.65	1.58	1.50	1.41	1.35	1.30	1.22
	C = 1.0	7.68	3.05	2.50	2.21	1.94	1.82	1.69	1.55	1.46	1.40	1.28
150	C = 0.6	2.00	1.73	1.62	1.54	1.46	1.41	1.36	1.30	1.26	1.23	1.16
	C = 0.8	3.00	2.24	2.0	1.84	1.69	1.61	1.53	1.43	1.36	1.31	1.23
	C = 1.0	-	3.32	2.65	2.30	2.00	1.87	1.73	1.58	1.48	1.41	1.29
155	C = 0.6	2.06	1.77	1.65	1.57	1.48	1.43	1.38	1.31	1.27	1.24	1.17
	C = 0.8	3.25	2.33	2.06	1.89	1.72	1.65	1.55	1.45	1.38	1.33	1.23
	C = 1.0	-	3.66	2.80	2.40	2.06	1.92	1.77	1.61	1.51	1.43	1.30
160	C = 0.6	2.13	1.81	1.69	1.60	1.50	1.45	1.39	1.33	1.28	1.24	1.18
	C = 0.8	3.55	2.43	2.13	1.94	1.76	1.67	1.58	1.47	1.39	1.34	1.24
	C = 1.0	-	4.12	3.00	2.52	2.13	1.98	1.81	1.64	1.53	1.45	1.31
165	C = 0.6	2.21	1.86	1.72	1.62	1.52	1.47	1.41	1.34	1.29	1.25	1.18
	C = 0.8	3.96	2.55	2.21	2.00	1.80	1.71	1.60	1.49	1.41	1.35	1.25
	C = 1.0	-	4.80	3.23	2.65	2.21	2.04	1.86	1.67	1.55	1.47	1.33

# CLAMPEX® KTR 100

## Clamping elements

Not self-centering, suitable for large shaft and hub tolerances



For legend of pictogram refer to flapper on the cover

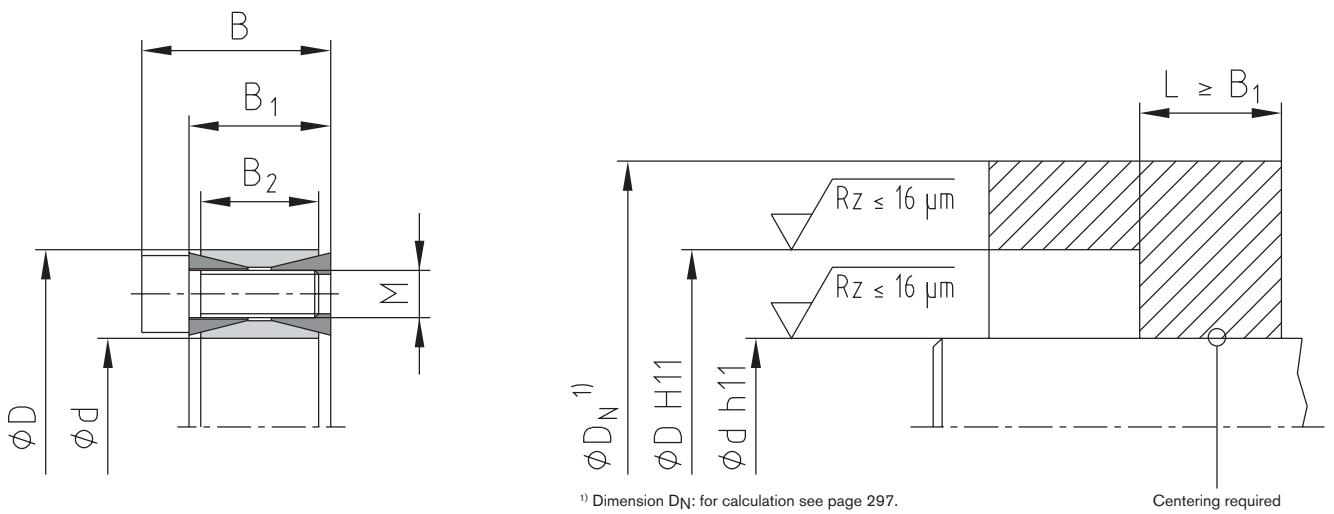

### Example of application of hub type

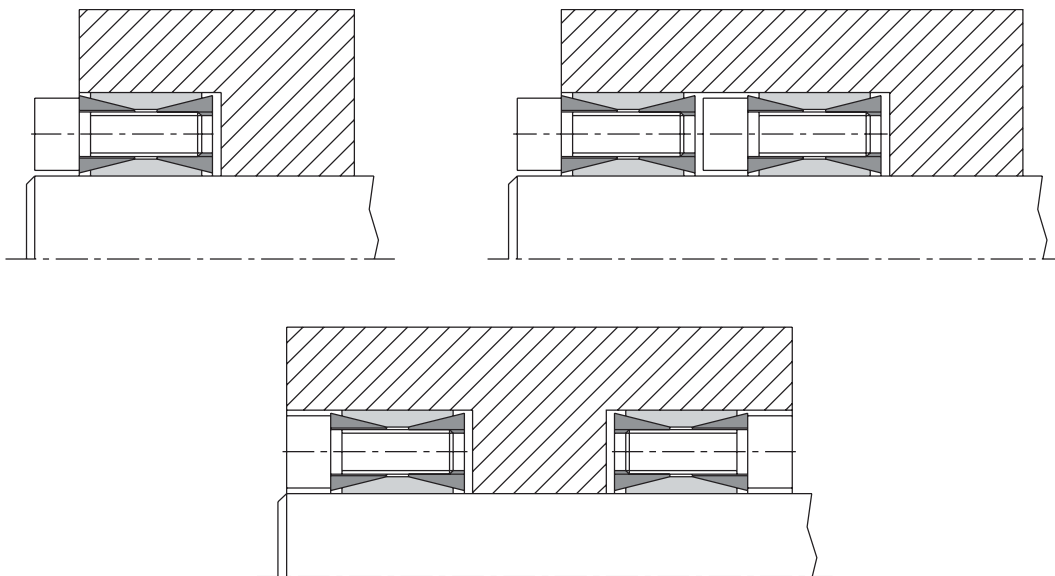

● Sizes of clamping elements available from stock.

<sup>1)</sup> These are the maximum screw tightening torques. They can be reduced by a maximum of 40 % of the above-mentioned figures with  $T$ ,  $F_{ax}$ ,  $P_W$  and  $P_N$  decreasing proportionately.

Ordering example:	KTR 100	50	x	80
	Series	Size of internal diameter d		Size of external diameter D

CLAMPEX® – KTR 100

d x D [mm]	Dimensions [mm]			Clamping screws DIN EN ISO 4762 - 12.9 $\mu_{total}=0.14$				Transmittable torque or axial force		Surface pressure between clamping element		Weight [-kg]	Stock programme
	B	B <sub>1</sub>	B <sub>2</sub>	M	Length	z = number	T <sub>A</sub> [Nm] <sup>1)</sup>	T [Nm]	F <sub>ax</sub> [kN]	Shaft P <sub>W</sub> [N/mm <sup>2</sup> ]	Hub P <sub>N</sub> [N/mm <sup>2</sup> ]		
17 x 47	26	20	17	M6	18	8	16	260	31	281	102	0.2	
18 x 47	26	20	17	M6	18	8	16	280	31	270	103	0.2	●
19 x 47	26	20	17	M6	18	8	16	290	31	251	101	0.2	●
20 x 47	26	20	17	M6	18	8	16	310	31	242	103	0.2	●
22 x 47	26	20	17	M6	18	8	16	340	31	219	103	0.2	●
24 x 50	26	20	17	M6	18	8	16	370	31	200	96	0.3	●
25 x 50	26	20	17	M6	18	8	16	390	31	195	97	0.3	●
28 x 55	26	20	17	M6	18	12	16	650	46	259	132	0.3	●
30 x 55	26	20	17	M6	18	12	16	700	47	243	132	0.3	●
32 x 60	26	20	17	M6	18	12	16	750	47	229	122	0.3	●
35 x 60	26	20	17	M6	18	12	16	820	47	209	122	0.3	●
38 x 65	26	20	17	M6	18	15	16	1100	58	238	139	0.4	●
40 x 65	26	20	17	M6	18	15	16	1170	59	228	140	0.3	●
42 x 75	32	24	20	M8	22	12	40	1670	80	251	141	0.6	●
45 x 75	32	24	20	M8	22	12	40	1790	80	234	141	0.5	●
48 x 80	32	24	20	M8	22	12	40	1900	79	219	131	0.6	●
50 x 80	32	24	20	M8	22	12	40	1990	80	211	132	0.6	●
55 x 85	32	24	20	M8	22	15	40	2740	100	240	155	0.6	●
60 x 90	32	24	20	M8	22	15	40	2990	100	220	147	0.7	●
65 x 95	32	24	20	M8	22	15	40	3240	100	203	139	0.8	●
70 x 110	38	28	24	M10	25	15	78	5550	159	250	159	1.3	●
75 x 115	38	28	24	M10	25	15	78	5950	159	234	152	1.2	●
80 x 120	38	28	24	M10	25	15	78	6350	159	219	146	1.4	●
85 x 125	38	28	24	M10	25	15	78	6740	159	206	140	1.4	●
90 x 130	38	28	24	M10	25	15	78	7140	159	195	135	1.5	●
95 x 135	38	28	24	M10	25	18	78	9000	189	220	155	1.6	●
100 x 145	44	32	26	M12	30	15	135	11600	232	237	163	2.2	●
110 x 155	44	32	26	M12	30	15	135	12750	232	215	153	2.3	●
120 x 165	44	32	26	M12	30	16	135	14800	247	210	153	2.4	●
130 x 180	50	38	34	M12	30	20	135	20150	310	186	134	3.5	●
140 x 190	50	38	34	M12	30	22	135	23850	341	190	140	3.8	●
150 x 200	50	38	34	M12	30	24	135	27850	371	193	145	4.0	●
160 x 210	50	38	34	M12	30	26	135	32200	403	196	150	4.4	●
170 x 225	58	44	38	M14	45	22	215	40300	474	195	147	5.7	●
180 x 235	58	44	38	M14	45	24	215	46600	518	201	154	6.0	●
190 x 250	66	52	46	M14	45	28	215	57300	603	183	139	8.0	●
200 x 260	66	52	46	M14	45	30	215	71000	710	205	157	8.2	●
220 x 285	72	56	50	M16	50	26	335	93200	847	204	158	11.0	●
240 x 305	72	56	50	M16	50	30	335	117300	978	216	170	12.2	●
260 x 325	72	56	50	M16	50	34	335	144000	1108	226	181	13.2	●
280 x 355	84	66	60	M18	60	32	465	177700	1269	200	158	19.2	●
300 x 375	84	66	60	M18	60	36	465	214100	1427	210	168	20.5	●
320 x 405	98	78	72	M20	70	36	660	295800	1849	213	168	29.6	●
340 x 425	98	78	72	M20	70	36	660	314300	1849	200	160	31.1	●
360 x 455	112	90	84	M22	80	36	900	413300	2296	201	159	42.2	●
380 x 475	112	90	84	M22	80	36	900	436300	2296	191	153	44.0	●
400 x 495	112	90	84	M22	80	36	900	459300	2297	181	147	46.0	●
420 x 515	112	90	84	M22	80	40	900	535800	2551	192	156	50.0	●
440 x 545	130	102	96	M24	90	40	1130	647600	2944	185	149	64.6	●
460 x 565	130	102	96	M24	90	40	1130	677000	2943	177	144	67.4	●
480 x 585	130	102	96	M24	90	42	1130	741800	3091	178	146	71.0	●
500 x 605	130	102	96	M24	90	44	1130	809500	3238	179	148	72.6	●
520 x 630	130	102	96	M24	90	45	1130	861000	3312	176	145	80	●
540 x 650	130	102	96	M24	90	45	1130	894000	3311	169	141	82	●
560 x 670	130	102	96	M24	90	48	1130	989000	3532	174	146	85	●
580 x 690	130	102	96	M24	90	50	1130	1067000	3679	175	147	88	●
600 x 710	130	102	96	M24	90	50	1130	1103800	3679	169	143	91	●
620 x 730	130	102	96	M24	90	52	1130	1186200	3826	171	145	93	●
640 x 750	130	102	96	M24	90	54	1130	1271600	3974	172	146	96	●
660 x 770	130	102	96	M24	90	56	1130	1359900	4121	173	148	99	●
680 x 790	130	102	96	M24	90	56	1130	1401100	4121	167	144	102	●
700 x 810	130	102	96	M24	90	60	1130	1545400	4415	174	151	104	●
720 x 830	130	102	96	M24	90	60	1130	1589500	4415	169	147	107	●
740 x 850	130	102	96	M24	90	62	1130	1688100	4562	170	148	110	●
760 x 870	130	102	96	M24	90	64	1130	1789700	4710	171	150	113	●
780 x 890	130	102	96	M24	90	65	1130	1865500	4783	169	149	116	●
800 x 910	130	102	96	M24	90	66	1130	1942700	4857	168	147	118	●
820 x 930	130	102	96	M24	90	68	1130	2051600	5004	169	149	121	●
840 x 950	130	102	96	M24	90	70	1130	2163500	5151	169	150	124	●
860 x 970	130	102	96	M24	90	72	1130	2278300	5298	170	151	127	●
880 x 990	130	102	96	M24	90	74	1130	2396000	5445	171	152	129	●
900 x 1010	130	102	96	M24	90	75	1130	2483600	5519	169	151	132	●
920 x 1030	130	102	96	M24	90	76	1130	2572600	5593	168	150	135	●
940 x 1050	130	102	96	M24	90	78	1130	2697700	5740	169	151	138	●
960 x 1070	130	102	96	M24	90	80	1130	2825800	5887	169	152	140	●
980 x 1090	130	102	96	M24	90	81	1130	2920700	5961	168	151	143	●
1000 x 1110	130	102	96	M24	90	82	1130	3017100	6034	167	150	146	●

CLAMPEX®

Clamping nuts

KTR Precision joints

Clamping sets

# CLAMPEX® KTR 105

## Clamping elements

### Self-centering clamping element in a compact design

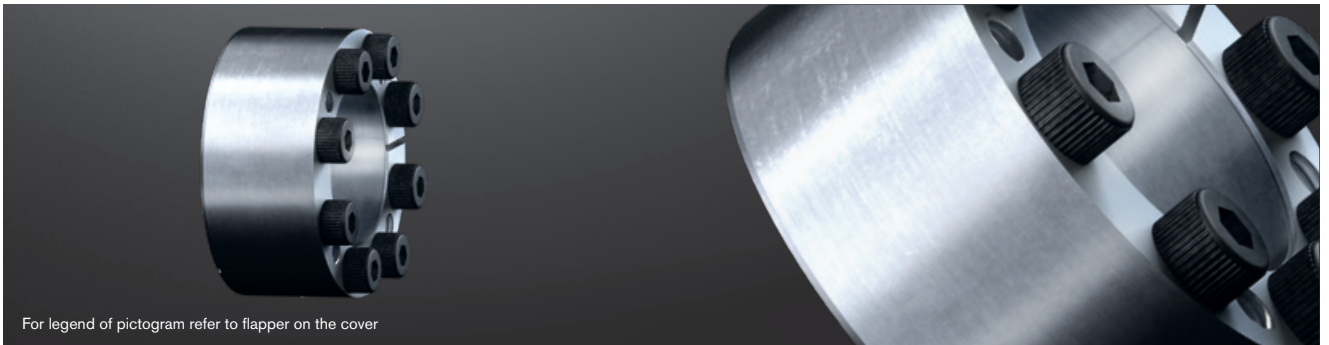

For legend of pictogram refer to flapper on the cover

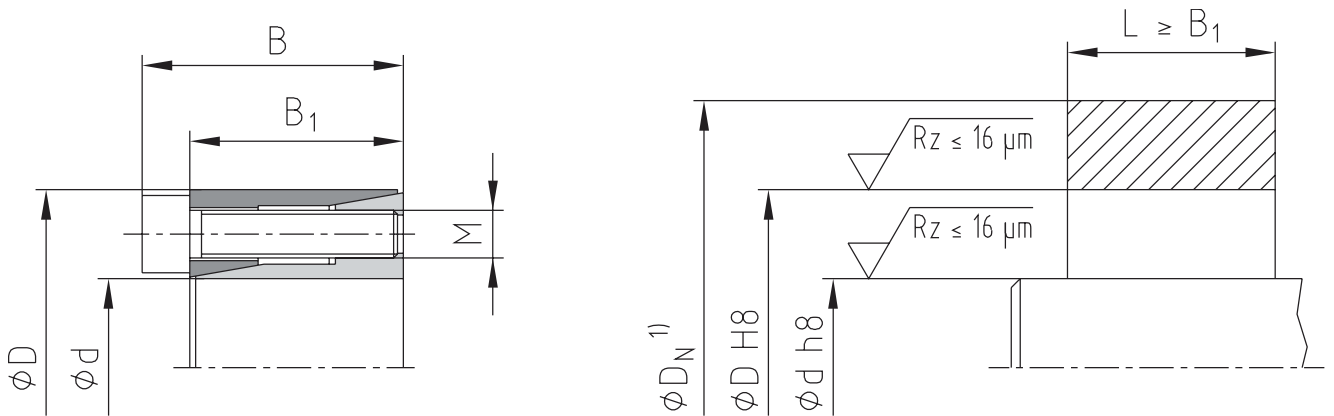

<sup>1)</sup> Dimension DN: for calculation see page 297.

#### Example of application of hub type

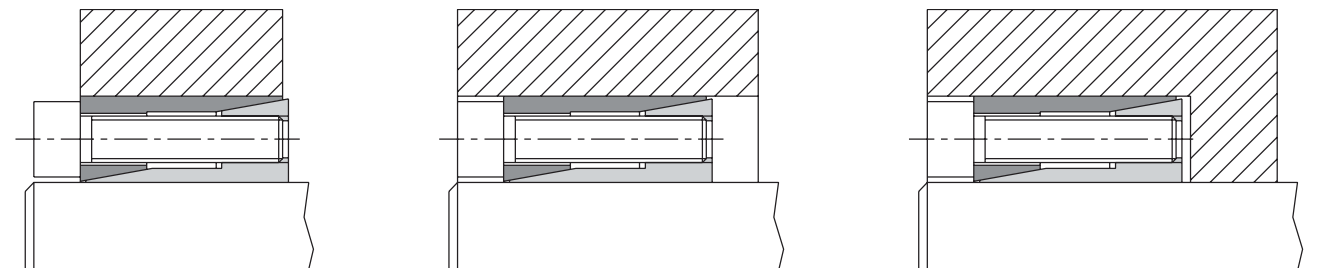

Ordering example:	KTR 105	8	x	18
	Series	Size of internal diameter d		Size of external diameter D

CLAMPEX® – KTR 105													
d x D [mm]	Dimensions [mm]		Clamping screws DIN EN ISO 4762 - 12.9 $\mu_{total}=0.14$				Transmittable torque or axial force			Surface pressure between clamping element		Weight [-kg]	Stock programme
	B	B1	M	Length	z = number	$T_A$ [Nm] <sup>1)</sup>	T [Nm]	$F_{ax}$ [kN]	Shaft $P_W$ [N/mm <sup>2</sup> ]	Hub $P_N$ [N/mm <sup>2</sup> ]			
5 x 16	13.5	11	M2.5	10	3	1.2	5	2	177	55	0.01	●	
6 x 16	13.5	11	M2.5	10	3	1.2	6	2	147	55	0.01	●	
6.35 x 16	13.5	11	M2.5	10	3	1.2	6	2	132	52	0.01	●	
7 x 17	13.5	11	M2.5	10	3	1.2	8	2	144	59	0.01	●	
8 x 18	13.5	11	M2.5	10	3	1.2	10	3	138	61	0.02	●	
9 x 20	15.5	13	M2.5	12	4	1.2	15	3	140	63	0.02	●	
9.53 x 20	15.5	13	M2.5	12	4	1.2	15	3	125	60	0.02	●	
10 x 20	15.5	13	M2.5	12	4	1.2	15	3	114	57	0.02	●	
11 x 22	15.5	13	M2.5	12	4	1.2	18	3	113	56	0.02	●	
12 x 22	15.5	13	M2.5	12	4	1.2	20	3	105	57	0.02	●	
14 x 26	20	17	M3	16	4	2.1	35	5	105	57	0.04	●	
15 x 28	20	17	M3	16	4	2.1	40	5	94	51	0.04	●	
16 x 32	21	17	M4	16	4	4.9	70	9	132	66	0.07	●	
17 x 35	25	21	M4	20	4	4.9	75	9	125	61	0.09	●	
18 x 35	25	21	M4	20	4	4.9	80	9	119	61	0.09	●	
19 x 35	25	21	M4	20	4	4.9	85	9	114	62	0.08	●	
20 x 38	26	21	M5	20	4	9.7	150	15	153	81	0.1	●	
22 x 40	26	21	M5	20	4	9.7	160	15	135	74	0.1	●	
24 x 47	32	26	M6	25	4	16.5	250	21	154	78	0.2	●	
25 x 47	32	26	M6	25	4	16.5	260	21	147	78	0.2	●	
28 x 50	32	26	M6	25	6	16.5	440	31	198	111	0.2	●	
30 x 55	32	26	M6	25	6	16.5	470	31	185	101	0.3	●	
32 x 55	32	26	M6	25	6	16.5	500	31	173	100	0.25	●	
35 x 60	37	31	M6	30	8	16.5	730	42	166	97	0.35	●	
38 x 65	37	31	M6	30	8	16.5	800	42	155	90	0.4	●	
40 x 65	37	31	M6	30	8	16.5	840	42	147	90	0.4	●	
42 x 75	44	36	M8	35	6	40	911	43	125	70	0.7	●	
45 x 75	44	36	M8	35	8	40	1300	58	155	93	0.6	●	
48 x 80	44	36	M8	35	8	40	1824	76	191	115	0.7	●	
50 x 80	44	36	M8	35	8	40	1900	76	183	115	0.7	●	

● Sizes of clamping elements available from stock.

<sup>1)</sup> These are the maximum screw tightening torques. They can be reduced by a maximum of 40 % of the above-mentioned figures with T,  $F_{ax}$ ,  $P_W$  and  $P_N$  decreasing proportionately.

# CLAMPEX® KTR 130 and KTR 131

## Clamping elements

Self-centering clamping elements with a central clamping nut for easy assembly/disassembly

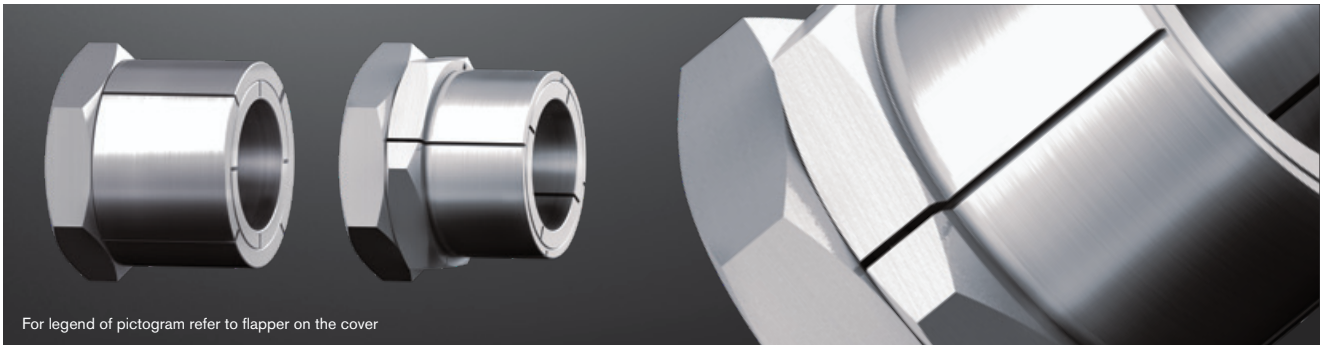

For legend of pictogram refer to flapper on the cover

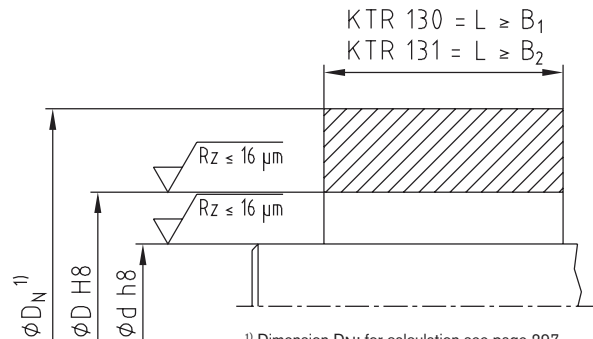
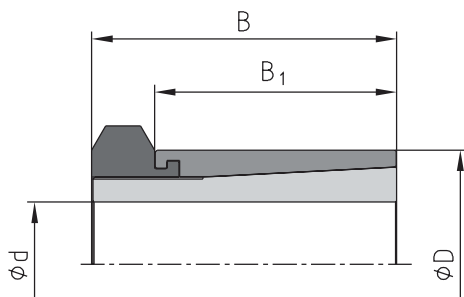
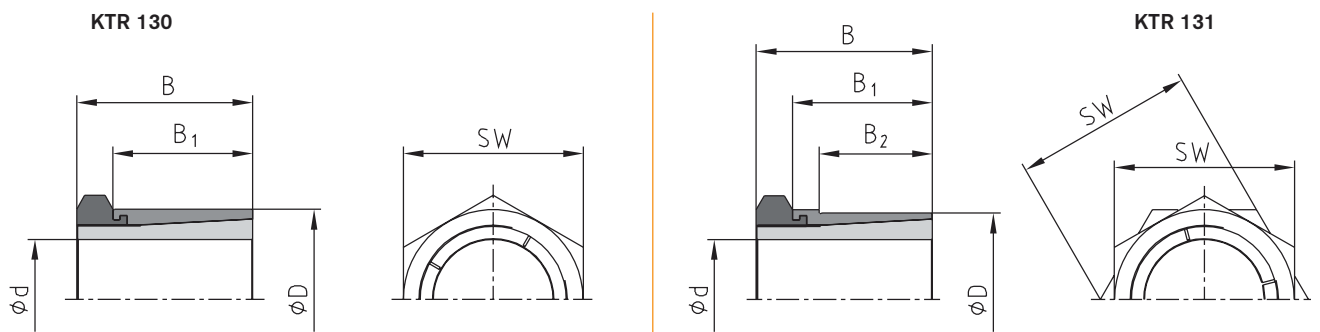

<sup>1)</sup> Dimension D<sub>N</sub>: for calculation see page 297.

### Example of application of hub type

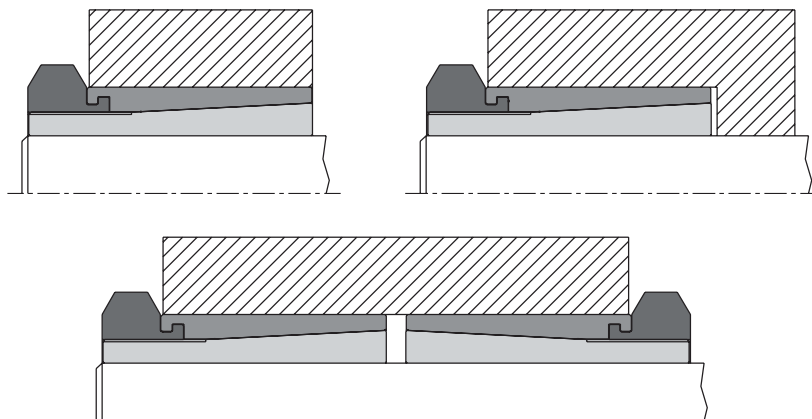

Ordering example:	KTR 130	18	x	35
	Series	Size of internal diameter d		Size of external diameter D

CLAMPEX® – KTR 130											
d x D [mm]	Dimensions [mm]		Hexagon nut		Transmittable torque or axial force			Surface pressure between clamping element		Weight [~kg]	Stock programme
	B	B <sub>1</sub>	Width across flats SW	T <sub>A</sub> [Nm] <sup>1)</sup>	T [Nm]	F <sub>ax</sub> [kN]	Shaft P <sub>W</sub> [N/mm <sup>2</sup> ]	Hub P <sub>N</sub> [N/mm <sup>2</sup> ]			
5 x 14	19	15	14	10	10.1	4.0	264	96	0.02	●	
6 x 14	19	15	14	10	12.1	4.0	220	96	0.02	●	
8 x 16	22	17	17	17	23.4	5.8	179	91	0.02	●	
9 x 20	24	19	22	35	43.2	9.7	248	112	0.04	●	
10 x 20	24	19	22	35	48.6	9.7	223	112	0.05	●	
12 x 22	24	19	22	44	65.3	10.9	206	117	0.05	●	
14 x 26	28	22	27	65	93.0	13.3	178	99	0.08	●	
15 x 26	28	22	27	65	99.0	13.3	166	99	0.08	●	
16 x 26	28	22	27	65	106	13.3	156	99	0.07	●	
18 x 35	36	27	36	161	223	24.8	224	125	0.2	●	
19 x 35	36	27	36	161	235	24.8	212	125	0.2	●	
20 x 35	36	27	36	161	248	24.8	201	125	0.2	●	
22 x 42	41	30	46	250	349	31.8	197	110	0.3	●	
24 x 42	41	30	46	250	381	31.8	180	110	0.3	●	
25 x 42	41	30	46	250	397	31.8	173	110	0.3	●	
30 x 47	44	33	50	355	605	40.4	162	110	0.4	●	
32 x 55	51	38	55	490	764	47.8	166	102	0.6	●	
35 x 55	51	38	55	490	836	47.8	151	102	0.6	●	
40 x 62	58	43	65	800	1329	66.5	152	98	0.8	●	
45 x 65	63	48	65	900	1605	71.0	142	98	0.9	●	
48 x 75	73	58	75	1290	2227	92.0	121	77	1.5	●	
50 x 75	73	58	75	1290	2320	92.0	116	77	1.4	●	

● Sizes of clamping elements available from stock.

<sup>1)</sup> These are the maximum screw tightening torques. They can be reduced by a maximum of 40 % of the above-mentioned figures with T, F<sub>ax</sub>, P<sub>W</sub> and P<sub>N</sub> decreasing proportionately.

CLAMPEX® – KTR 131											
d x D [mm]	Dimensions [mm]			Hexagon nut/ counter hexagon nut		Transmittable torque or axial force		Surface pressure between clamping element		Weight [~kg]	Stock programme
	B	B <sub>1</sub>	B <sub>2</sub>	Width across flats SW	T <sub>A</sub> [Nm] <sup>1)</sup>	T [Nm]	F <sub>ax</sub> [kN]	Shaft P <sub>W</sub> [N/mm <sup>2</sup> ]	Hub P <sub>N</sub> [N/mm <sup>2</sup> ]		
5 x 12	19	15	9	14	10	10.1	4.0	264	119	0.02	●
6 x 12	19	15	9	14	10	12.1	4.0	220	119	0.02	●
8 x 14	22	17	11	17	17	23.4	5.8	179	121	0.02	●
10 x 18	24	19	12	22	35	48.6	9.7	221	127	0.04	●
12 x 20	24	19	12	22	44	65.3	10.9	206	128	0.04	●
14 x 24	28	22	15	27	65	93.0	13.3	178	107	0.08	●
15 x 24	28	22	15	27	65	99.0	13.3	166	107	0.07	●
16 x 24	28	22	15	27	65	106	13.3	156	107	0.07	●
18 x 30	36	27	17	36	161	223	24.8	224	145	0.2	●
19 x 30	36	27	17	36	161	235	24.8	212	145	0.2	●
20 x 30	36	27	17	36	161	248	24.8	201	145	0.15	●
22 x 38	41	30	20	46	250	349	31.8	197	122	0.35	●
24 x 38	41	30	20	46	250	381	31.8	180	122	0.3	●
25 x 38	41	30	20	46	250	397	31.8	173	122	0.3	●
30 x 42	44	33	23	50	355	605	40.4	162	123	0.35	●
32 x 50	51	38	28	55	490	764	47.8	166	112	0.55	●
35 x 50	51	38	28	55	490	836	47.8	151	112	0.5	●

● Sizes of clamping elements available from stock.

<sup>1)</sup> These are the maximum screw tightening torques. They can be reduced by a maximum of 40 % of the above-mentioned figures with T, F<sub>ax</sub>, P<sub>W</sub> and P<sub>N</sub> decreasing proportionately.

# CLAMPEX® KTR 150

## Clamping elements

### Not self-centering clamping element with minimum dimensions



For legend of pictogram refer to flapper on the cover

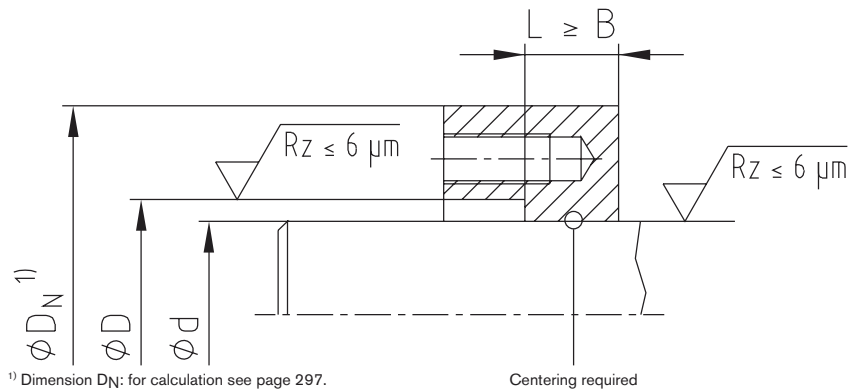
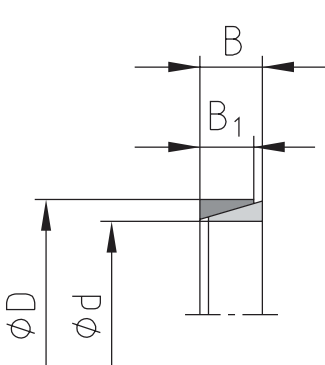

<sup>1)</sup> Dimension DN: for calculation see page 297.

Centering required

#### Tolerances for d and D

$$d \leq 38 \text{ mm} = d \text{ h6/D H7}$$

$$d > 38 \text{ mm} = d \text{ h8/D H8}$$

#### Example of application of hub type

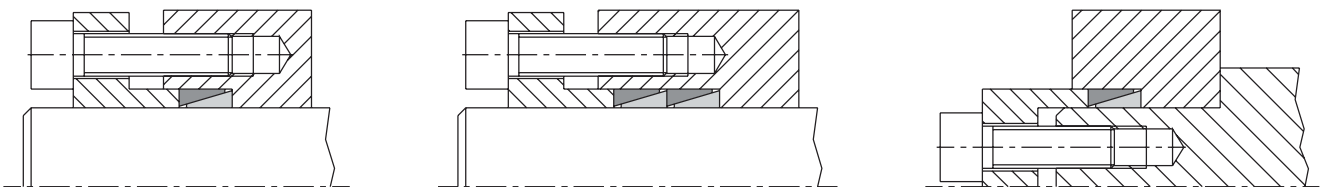

Up to four clamping elements can be installed one after another.

The torques rise as follows:

- 1 clamping element  $T = T_{\text{catalogue}} \times 1.00$
- 2 clamping elements  $T = T_{\text{catalogue}} \times 1.55$
- 3 clamping elements  $T = T_{\text{catalogue}} \times 1.85$
- 4 clamping elements  $T = T_{\text{catalogue}} \times 2.02$

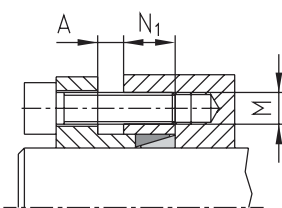

#### Pressure flanges

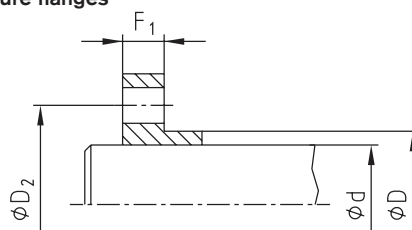

#### Recommended dimensions of pressure flanges:

- $N_1 \text{ [mm]} \geq 1.5 \cdot B$
- $D_2 \text{ [mm]} = D + 12 + M$
- $F_1 \text{ [mm]} = M \cdot 1.3$  (with screws 8.8)
- $F_1 \text{ [mm]} = M \cdot 1.8$  (with screws 10.9/12.9)

<b>Ordering example:</b>	KTR 150	60	x	68
	Series	Size of internal diameter d		Size of external diameter D

**CLAMPEX® – KTR 150**

d x D [mm]	Dimensions [mm]		Distance dimension A [mm]				Clamping force required for clamping screws $\mu_{total}=0.14$			Transmittable torque or axial force		Surface pressure between clamping element		Weight [~kg]	Stock programme
	B	B <sub>1</sub>	Clamping elements				PO [kN]	PS [kN]	PA = PO+PS [kN]	T [Nm]	F <sub>ax</sub> [kN]	Shaft P <sub>V</sub> [N/mm <sup>2</sup> ]	Hub P <sub>N</sub> [N/mm <sup>2</sup> ]		
			1	2	3	4									
6 x 9	4.5	3.7	3	3	3	4	0	3	3	2	0.6	80	53	0.0015	●
7 x 10	4.5	3.7	3	3	3	4	0	5	5	4	1	117	82	0.0014	●
8 x 11	4.5	3.7	3	3	3	4	0	6	6	5	1	112	81	0.0015	●
9 x 12	4.5	3.7	3	3	3	4	8	8	16	8	1	142	106	0.0017	●
10 x 13	4.5	3.7	3	3	3	4	7	9	16	10	2	143	110	0.0018	●
12 x 15	4.5	3.7	3	3	3	4	7	8	15	11	1	110	88	0.0022	●
13 x 16	4.5	3.7	3	3	3	4	6	10	16	13	2	110	90	0.0023	●
14 x 18	6.3	5.3	3	4	4	5	11	15	26	22	3	112	87	0.0049	●
15 x 19	6.3	5.3	3	4	4	5	11	15	26	25	3	111	88	0.0053	●
16 x 20	6.3	5.3	3	4	4	5	10	15	25	26	3	102	81	0.0055	●
17 x 21	6.3	5.3	3	4	4	5	10	16	26	30	3	104	84	0.0058	●
18 x 22	6.3	5.3	3	4	4	5	9	17	26	33	3	102	83	0.0061	●
19 x 24	6.3	5.3	3	4	4	5	13	19	32	40	4	111	88	0.0078	●
20 x 25	6.3	5.3	3	4	4	5	12	20	32	44	4	110	88	0.0082	●
22 x 26	6.3	5.3	3	4	4	5	9	21	30	50	4	103	87	0.0072	●
24 x 28	6.3	5.3	3	4	4	5	8	26	34	68	5	118	101	0.0079	●
25 x 30	6.3	5.3	3	4	4	5	10	27	37	75	6	120	100	0.01	●
28 x 32	6.3	5.3	3	4	4	5	7	30	37	90	6	115	101	0.009	●
30 x 35	6.3	5.3	3	4	4	5	8	31	39	100	6	111	95	0.012	●
32 x 36	6.3	5.3	3	4	4	5	8	34	42	120	7	117	104	0.01	●
35 x 40	7	6.0	3	4	4	5	13	42	55	160	9	115	101	0.02	●
36 x 42	7	6.0	4	5	5	6	15	43	58	170	9	116	99	0.02	●
38 x 44	7	6.0	4	5	5	6	14	46	60	190	10	116	100	0.02	●
40 x 45	8	6.6	4	5	5	6	14	53	67	230	11	116	103	0.02	●
42 x 48	8	6.6	4	5	5	6	16	57	73	260	12	118	104	0.03	●
45 x 52	10	8.6	4	5	5	6	26	80	106	390	17	119	103	0.05	●
48 x 55	10	8.6	4	5	5	6	25	82	107	430	17	115	100	0.05	●
50 x 57	10	8.6	4	5	5	6	24	86	110	470	18	116	102	0.05	●
55 x 62	10	8.6	4	5	5	6	22	97	119	580	21	118	105	0.05	●
56 x 64	12	10.4	4	5	5	6	29	122	151	740	26	120	105	0.07	●
60 x 68	12	10.4	4	5	6	7	27	129	156	840	28	119	105	0.07	●
63 x 71	12	10.4	4	5	6	7	26	134	160	920	29	118	105	0.08	●
65 x 73	12	10.4	4	5	6	7	25	142	167	1000	30	121	108	0.08	●
70 x 79	14	12.2	4	5	6	7	31	171	202	1300	37	115	102	0.11	●
71 x 80	14	12.2	4	5	6	7	31	181	212	1400	39	121	107	0.11	●
75 x 84	14	12.2	4	5	6	7	34	184	218	1500	40	116	104	0.12	●
80 x 91	17	15.0	5	6	7	8	48	241	289	2100	52	116	102	0.12	●
85 x 96	17	15.0	5	6	7	8	45	260	305	2400	56	117	104	0.2	●
90 x 101	17	15.0	5	6	7	8	43	276	319	2700	60	118	105	0.2	●
95 x 106	17	15.0	5	6	8	9	41	290	331	3000	63	118	105	0.22	●
100 x 114	21	18.7	5	6	8	9	61	386	447	4200	84	119	105	0.4	●
110 x 124	21	18.7	5	6	8	9	65	393	458	4700	85	110	98	0.4	●
120 x 134	21	18.7	5	6	8	9	60	391	451	5100	85	100	90	0.5	●
130 x 148	28	25.3	6	7	9	11	96	573	669	8100	124	101	88	0.85	●
140 x 158	28	25.3	6	7	9	11	89	618	707	9400	134	101	89	0.91	●
150 x 168	28	25.3	6	7	9	11	84	674	758	11000	146	103	92	0.97	●
160 x 178	28	25.3	6	7	9	11	79	833	912	14500	181	119	107	1.02	●
170 x 191	33	30.0	7	8	10	12	118	1054	1172	19500	229	119	106	1.5	●
180 x 201	33	30.0	7	8	10	12	112	1082	1194	21200	235	116	104	1.6	●
190 x 211	33	30.0	7	9	10	12	106	1166	1272	24100	253	118	106	1.7	●
200 x 224	38	34.5	7	9	11	13	133	1425	1558	31000	310	119	106	2.3	●
210 x 234	38	34.5	7	9	11	13	127	1532	1659	35000	333	122	110	2.5	●
220 x 244	38	34.5	7	9	11	13	122	1587	1709	38000	345	121	109	2.5	●
230 x 257	43	39.5	7	9	12	14	165	1579	1744	39500	343	100	90	3.4	●
240 x 267	43	39.5	7	9	12	14	158	1801	1959	47000	391	110	99	3.5	●
250 x 280	48	44.0	8	10	13	16	188	1912	2100	52000	416	100	90	4.7	●
260 x 290	48	44.0	8	10	13	16	181	1997	2178	56500	434	101	90	4.8	●
270 x 300	48	44.0	8	10	13	16	174	2077	2251	61000	451	101	91	4.9	●
280 x 313	53	49.0	9	11	14	17	205	2381	2586	72500	517	100	90	6.3	●
290 x 323	53	49.0	9	11	14	17	221	2457	2678	77500	534	100	90	6.5	●
300 x 333	53	49.0	9	11	14	17	214	2544	2758	83000	553	100	90	6.7	●
320 x 360	65	59.0	10	15	20	25	291	3275	3566	114000	712	100	89	10.9	●
340 x 380	65	59.0	10	15	20	25	275	3474	3749	128500	755	100	89	11.5	●
360 x 400	65	59.0	10	15	20	25	261	3677	3938	144000	800	100	90	12.2	●
380 x 420	65	59.0	10	15	20	25	269	3870	4139	160000	842	100	90	12.8	●
400 x 440	65	59.0	10	15	20	25	256	4091	4347	178000	890	100	91	13.5	●
420 x 460	65	59.0	10	15	20	25	244	4290	4534	196000	933	100	91	14.1	●
440 x 480	65	59.0	10	15	20	25	234	4492	4726	215000	977	100	92	14.7	●

● Sizes of clamping elements available from stock.  
Other sizes on request.

PA = Total force  
PO = Setting force  
PS = Clamping force

# CLAMPEX® KTR 200 and KTR 201 Clamping elements

Self-centering clamping elements with a wide range of applications

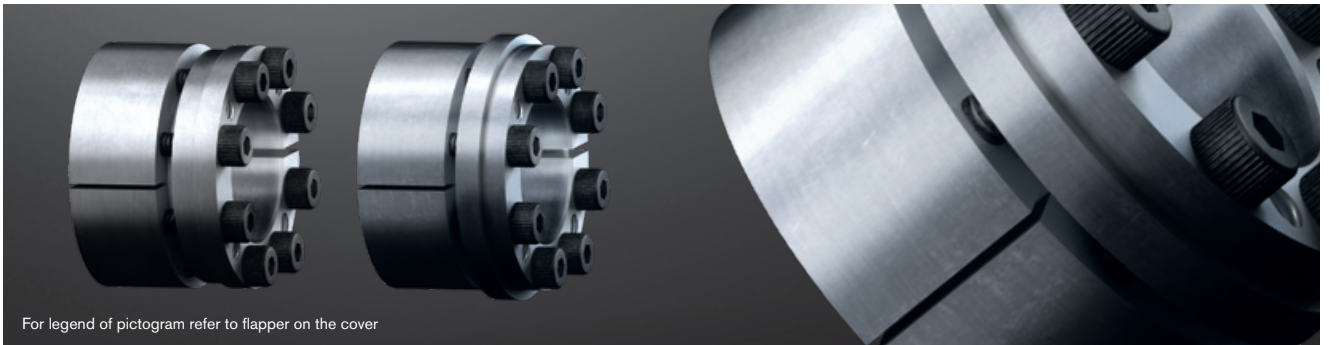

For legend of pictogram refer to flapper on the cover

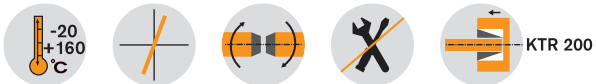

## KTR 200

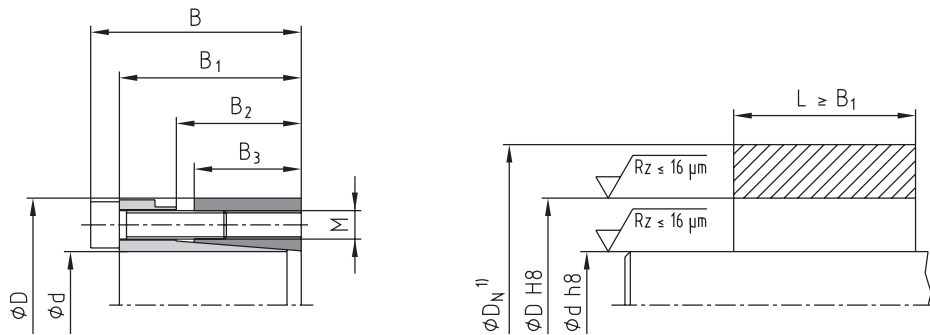

<sup>1)</sup> Dimension  $D_N$ : for calculation see page 297.

### Example of application of hub type

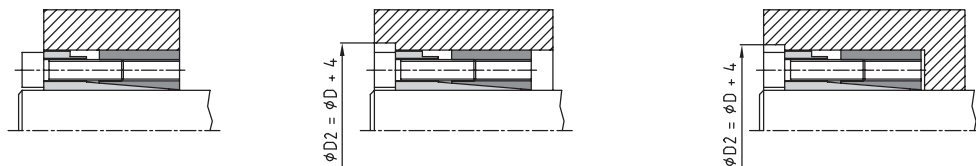

## KTR 201

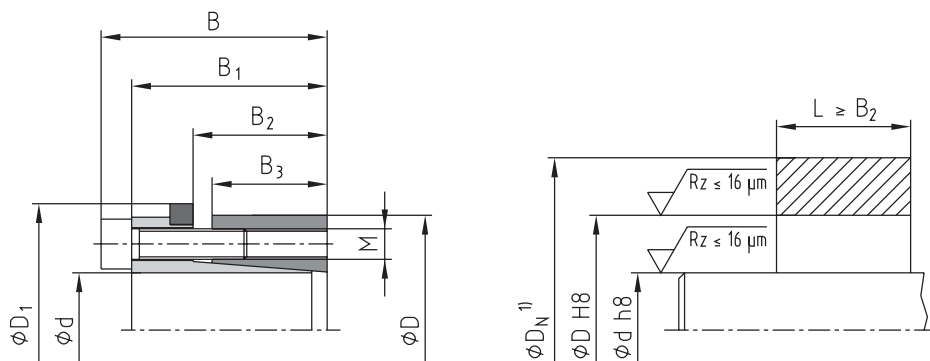

<sup>1)</sup> Dimension  $D_N$ : for calculation see page 297.

### Example of application of hub type

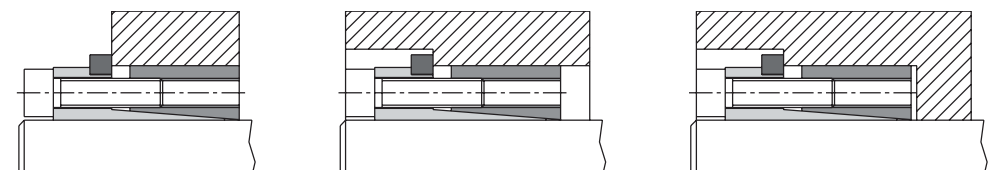

Ordering  
example:

KTR 200	40	x	65
Series	Size of internal diameter d		Size of external diameter D

CLAMPEX® – KTR 200 and KTR 201

d x D [mm]	Dimensions [mm]					Clamping screws DIN EN ISO 4762 - 12.9 $\mu_{total}=0.14$					KTR 200				KTR 201							
											Transmittable torque or axial force		Surface pressure between clamping element		Weight [~kg]	Stock programme	Transmittable torque or axial force		Surface pressure between clamping element		Weight [~kg]	Stock programme
	T [Nm]	F <sub>ax</sub> [kN]	Shaft P <sub>W</sub> [N/mm <sup>2</sup> ]	Hub P <sub>N</sub> [N/mm <sup>2</sup> ]	T [Nm]	F <sub>ax</sub> [kN]	Shaft P <sub>W</sub> [N/mm <sup>2</sup> ]	Hub P <sub>N</sub> [N/mm <sup>2</sup> ]														
20 x 47	48	42	31	26	53	M6	25	6	17	17	530	53	270	115	0.4	●	320	32	163	69	0.4	●
22 x 47	48	42	31	26	53	M6	25	6	17	17	580	53	245	114	0.4	●	360	33	152	71	0.4	●
24 x 50	48	42	31	26	56	M6	25	6	17	17	630	53	223	107	0.4	●	390	33	138	66	0.4	●
25 x 50	48	42	31	26	56	M6	25	6	17	17	660	53	215	108	0.4	●	400	32	131	65	0.4	●
28 x 55	48	42	31	26	61	M6	25	6	17	17	740	53	193	98	0.5	●	450	32	117	60	0.5	●
30 x 55	48	42	31	26	61	M6	25	6	17	17	790	53	179	98	0.5	●	490	33	111	61	0.5	●
32 x 60	48	42	31	26	66	M6	25	8	17	17	1150	72	229	122	0.6	●	690	43	137	73	0.6	●
35 x 60	48	42	31	26	66	M6	25	8	17	17	1300	74	217	126	0.5	●	750	43	125	73	0.5	●
38 x 65	48	42	31	26	71	M6	25	8	17	17	1300	68	184	107	0.6	●	820	43	116	68	0.6	●
40 x 65	48	42	31	26	71	M6	25	8	17	17	1400	70	179	110	0.6	●	860	43	110	67	0.6	●
42 x 75	59	51	35	30	81	M8	30	6	41	41	2000	95	200	112	1.0	●	1300	62	130	73	1.0	●
45 x 75	59	51	35	30	81	M8	30	6	41	41	2200	98	192	115	1.0	●	1400	62	122	73	1.0	●
48 x 80	59	51	35	30	86	M8	30	8	41	41	3200	133	246	147	1.1	●	1900	79	146	87	1.1	●
50 x 80	59	51	35	30	86	M8	30	8	41	41	3300	132	233	146	1.1	●	2000	80	141	88	1.1	●
55 x 85	59	51	35	30	91	M8	30	8	41	41	3600	131	210	136	1.2	●	2200	80	129	83	1.2	●
60 x 90	59	51	35	30	96	M8	30	8	41	41	3900	130	192	128	1.2	●	2400	80	118	79	1.2	●
65 x 95	59	51	35	30	101	M8	30	8	41	41	4300	132	180	123	1.3	●	2600	80	109	74	1.3	●
70 x 110	71	61	46	40	119	M10	30	8	83	83	7500	214	203	129	2.2	●	4600	131	125	79	2.3	●
75 x 115	71	61	46	40	124	M10	30	8	83	83	8000	213	189	123	2.3	●	5000	133	118	77	2.4	●
80 x 120	71	61	46	40	129	M10	30	8	83	83	8500	213	176	117	2.4	●	5200	130	108	72	2.6	●
85 x 125	71	61	46	40	134	M10	30	10	83	83	11400	268	209	142	2.6	●	7000	165	128	87	2.7	●
90 x 130	71	61	46	40	139	M10	30	10	83	83	12000	267	196	136	2.7	●	7400	164	121	84	2.8	●
95 x 135	71	61	46	40	144	M10	30	10	83	83	12600	265	185	130	2.8	●	7800	164	115	81	2.9	●
100 x 145	80	68	52	45	155	M12	35	8	145	145	15000	300	177	122	3.9	●	9800	196	116	80	4.1	●
110 x 155	80	68	52	45	165	M12	35	8	145	145	16500	300	161	114	4.2	●	10700	195	104	74	4.4	●
120 x 165	80	68	52	45	175	M12	35	10	145	145	22500	375	184	134	4.5	●	14600	243	120	87	4.7	●
130 x 180	80	68	52	45	188	M12	35	12	145	145	29000	446	202	146	5.5	●	19000	292	133	96	5.7	●
140 x 190	90	76	58	50	199	M14	40	10	210	230	32000	457	173	128	6.6	●	23000	329	125	92	6.9	●
150 x 200	90	76	58	50	209	M14	40	12	210	230	41000	547	193	145	6.9	●	30000	400	141	106	7.2	●
160 x 210	90	76	58	50	219	M14	40	12	210	230	44000	550	182	139	7.4	●	32000	400	133	101	7.8	●
170 x 225	90	76	58	50	234	M14	40	14	210	230	54500	641	200	151	8.6	●	39000	459	143	108	9.0	●
180 x 235	90	76	58	50	244	M14	40	14	210	230	57500	639	188	144	9.1	●	41000	456	134	103	9.5	●
190 x 250	90	76	58	50	259	M14	40	15	210	230	65000	684	191	145	10.6	●	46400	488	136	104	11.1	●
200 x 260	90	76	58	50	269	M14	40	15	210	230	68000	680	180	139	11.2	●	48800	488	129	100	11.7	●

● Sizes of clamping elements available from stock.

<sup>1)</sup> These are the maximum screw tightening torques. They can be reduced by a maximum of 40 % of the above-mentioned figures with T, F<sub>ax</sub>, P<sub>W</sub> and P<sub>N</sub> decreasing proportionately.

# CLAMPEX® KTR 203 and KTR 206

## Clamping elements

Self-centering clamping elements as a compact alternative to KTR 200/201

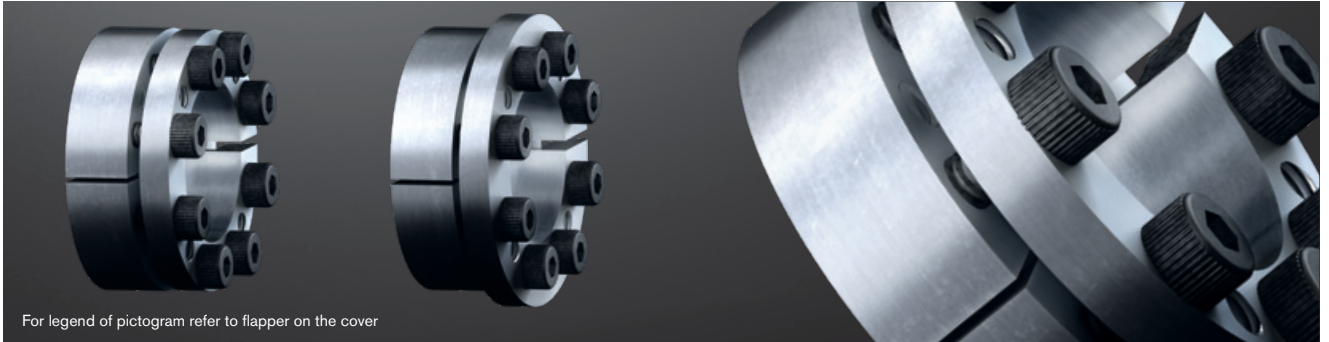

For legend of pictogram refer to flapper on the cover

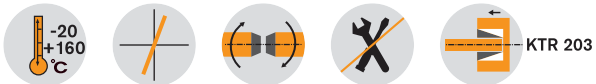

### KTR 203

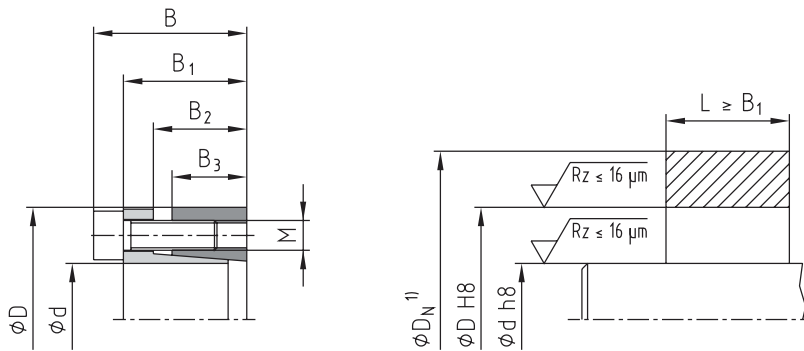

<sup>1)</sup> Dimension  $D_N$ : for calculation see page 297.

#### Example of application of hub type

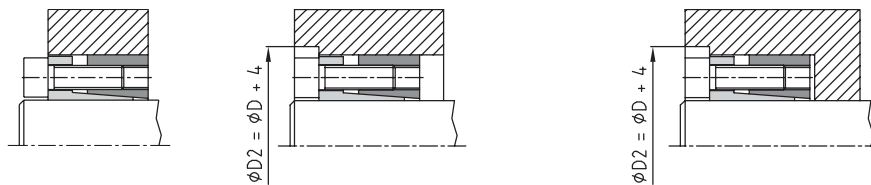

### KTR 206

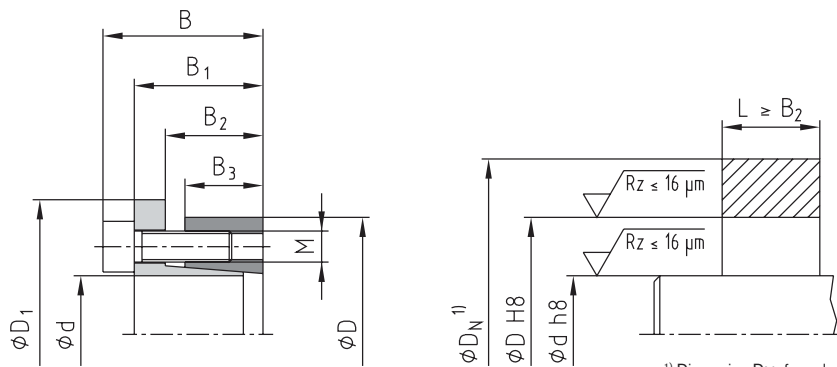

<sup>1)</sup> Dimension  $D_N$ : for calculation see page 297.

#### Example of application of hub type

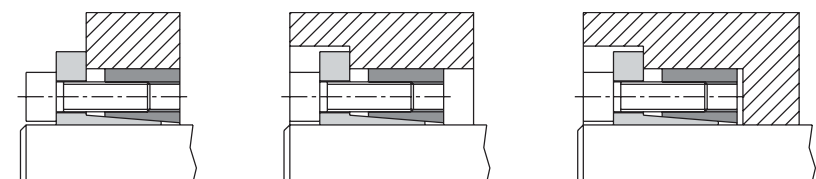

Ordering example:

KTR 203	40	x	65
Series	Size of internal diameter d		Size of external diameter D

CLAMPEX® – KTR 203 and KTR 206

d x D [mm]	Dimensions [mm]					Clamping screws DIN EN ISO 4762 - 12.9 $\mu_{total}=0.14$					KTR 203						KTR 206					
											Transmittable torque or axial force		Surface pressure between clamping element		Weight [-kg]	Stock programme	Transmittable torque or axial force		Surface pressure between clamping element		Weight [-kg]	Stock programme
	T [Nm]	F <sub>ax</sub> [kN]	Shaft PW [N/mm <sup>2</sup> ]	Hub PN [N/mm <sup>2</sup> ]	T [Nm]	F <sub>ax</sub> [kN]	Shaft PW [N/mm <sup>2</sup> ]	Hub PN [N/mm <sup>2</sup> ]														
18 x 47	34	28	22	17	53	M6	20	6	14	17	370	41	356	136	0.3		290	32	279	107	0.3	
19 x 47	34	28	22	17	53	M6	20	6	14	17	390	41	337	136	0.3		300	32	259	105	0.3	
20 x 47	34	28	22	17	53	M6	20	6	14	17	410	41	320	136	0.3	●	320	32	250	106	0.3	●
22 x 47	34	28	22	17	53	M6	20	6	14	17	450	41	290	136	0.3	●	350	32	226	106	0.3	●
24 x 50	34	28	22	17	56	M6	20	6	14	17	490	41	265	127	0.3	●	390	33	211	101	0.3	●
25 x 50	34	28	22	17	56	M6	20	6	14	17	510	41	255	127	0.3	●	400	32	200	100	0.3	●
28 x 55	34	28	22	17	61.4	M6	20	6	14	17	570	41	227	116	0.3	●	450	32	179	91	0.4	●
30 x 55	34	28	22	17	61.4	M6	20	6	14	17	610	41	212	115	0.3	●	490	33	170	93	0.3	●
32 x 60	34	28	22	17.5	67	M6	20	8	14	17	880	55	261	139	0.4	●	700	44	207	111	0.3	●
35 x 60	34	28	22	17.5	67	M6	20	8	14	17	960	55	238	139	0.3	●	760	43	188	110	0.4	●
38 x 65	34	28	22	17.5	72	M6	20	8	14	17	1000	53	210	123	0.4	●	820	43	172	101	0.5	●
40 x 65	34	28	22	17.5	72	M6	20	8	14	17	1100	55	208	128	0.4	●	870	44	165	101	0.4	●
42 x 75	41	33	25	20	84	M8	25	8	35	41	2200	105	331	185	0.6	●	1700	81	256	143	0.7	●
45 x 75	41	33	25	20	84	M8	25	8	35	41	2400	107	314	189	0.6	●	1800	80	236	141	0.7	●
48 x 80	41	33.5	24	20	89	M8	25	8	35	41	2500	104	288	173	0.7	●	1900	79	219	131	0.8	●
50 x 80	41	33.5	24	20	89	M8	25	8	35	41	2600	104	276	172	0.7	●	2000	80	212	133	0.8	●
55 x 85	41	33.5	24	20	94	M8	25	8	35	41	2900	105	254	165	0.7	●	2200	80	193	125	0.9	●
60 x 90	41	33.5	24	20	99	M8	25	8	35	41	3100	103	228	152	0.8	●	2400	80	177	118	0.9	●
65 x 95	41	33.5	24	20	104	M8	25	8	35	41	3400	105	213	146	0.8	●	2600	80	163	112	0.9	●
70 x 110	50	40	29	24	119	M10	30	8	70	83	6000	171	271	172	1.5	●	4600	131	208	132	1.6	●
75 x 115	50	40	29	24	124	M10	30	8	70	83	6400	171	252	164	1.6	●	5000	133	196	128	1.7	●
80 x 120	50	40	29	24	129	M10	30	8	70	83	6800	170	235	157	1.7	●	5300	133	183	122	1.9	●
85 x 125	50	40	29	24	134	M10	30	10	70	83	9000	212	275	187	1.8	●	7000	165	214	146	2.0	●
90 x 130	50	40	29	24	139	M10	30	10	70	83	9600	213	262	181	1.9	●	7400	164	202	140	2.0	●
95 x 135	50	40	29	24	144	M10	30	10	70	83	10200	215	250	176	2.0	●	7800	164	191	134	2.3	●
100 x 145	56	44	31	25.5	154	M12	30	8	115	145	12000	240	250	172	2.6	●	9700	194	202	139	2.8	●
110 x 155	56	44	31	25.5	164	M12	30	8	115	145	13000	236	224	159	2.8	●	10700	195	184	131	3.1	●
120 x 165	56	44	31	26	174	M12	30	9	115	145	16000	267	227	165	3.6	●	13100	218	186	135	3.2	●
130 x 180	64	52	39	34	189	M12	30	12	115	145	23000	354	212	153	4.4	●	19000	292	175	127	4.6	●
140 x 190	68	54	39	34	199	M14	40	9	185	230	25000	357	199	147	4.9	●	20500	293	163	120	5.0	●
150 x 200	68	54	39	34	209	M14	40	10	185	230	30000	400	208	156	5.2	●	24500	327	170	127	5.2	●
160 x 210	68	54	39	34	219	M14	40	12	185	230	38800	485	236	180	5.6	●	31300	391	191	145	5.6	●
170 x 225	78	64	49	44	234	M14	40	12	185	230	41300	486	172	130	6.9	●	33200	391	139	105	6.5	●
180 x 235	78	64	49	44	244	M14	40	12	185	230	43700	486	163	125	8.5	●	35000	389	130	100	8.5	●
190 x 250	78	64	49	43.5	259	M14	40	15	185	230	57700	607	195	148	9.0	●	46500	489	157	119	9.0	●
200 x 260	78	64	49	43.5	269	M14	40	15	185	230	60700	607	185	142	9.6	●	49000	490	149	115	9.6	●
220 x 285	88	72	57	50	294	M16	40	12	290	360	77300	703	169	131	13.4	●	57100	519	125	97	14.0	●
240 x 305	88	72	57	50	314	M16	40	15	290	360	105400	878	194	153	14.5	●	77800	648	143	113	15.1	●
260 x 325	88	72	57	50	334	M16	40	18	290	360	137000	1054	215	172	16.1	●	101200	778	159	127	16.2	●
280 x 355	102	84	66	60	364	M18	50	16	400	480	160300	1145	181	143	23.4	●	113300	809	128	101	25.6	●
300 x 375	102	84	66	60	384	M18	50	18	400	480	193200	1288	190	152	25.3	●	136500	910	134	107	25.5	●
320 x 405	121	101	81	74	414	M20	50	18	580	690	269300	1683	189	149	36.9	●	191000	1194	134	106	37.9	●
340 x 425	121	101	81	74	434	M20	50	21	580	690	333800	1964	207	166	39.0	●	237000	1394	147	118	38.3	●
360 x 455	138	116	93	86	464	M22	60	18	780	930	375700	2087	179	141	54.0	●	264000	1467	126	99	53.3	●
380 x 475	138	116	93	86	484	M22	60	21	780	930	462700	2435	198	158	56.2	●	325000	1711	139	111	57.6	●
400 x 495	138	116	93	86	504	M22	60	21	780	930	487000	2435	188	152	58.9	●	342000	1710	132	107	60.3	●

● Sizes of clamping elements available from stock.

<sup>1)</sup> These are the maximum screw tightening torques. They can be reduced by a maximum of 40 % of the above-mentioned figures with T, F<sub>ax</sub>, PW and P<sub>N</sub> decreasing proportionately.

# CLAMPEX® KTR 225

## Clamping elements

Self-centering, combination of a hub  $\varnothing$  with various shaft  $\varnothing$



For legend of pictogram refer to flapper on the cover

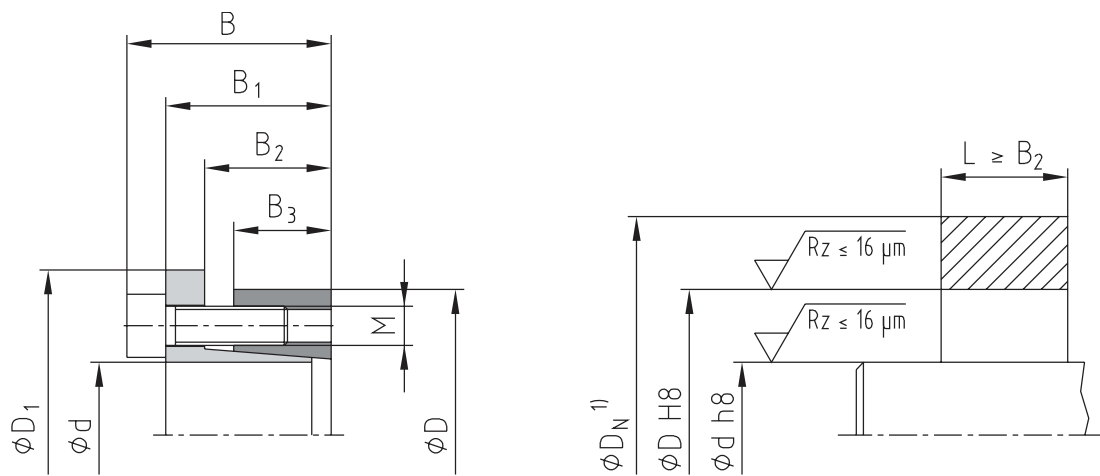

<sup>1)</sup> Dimension  $D_N$ : for calculation see page 297.

### Example of application of hub type

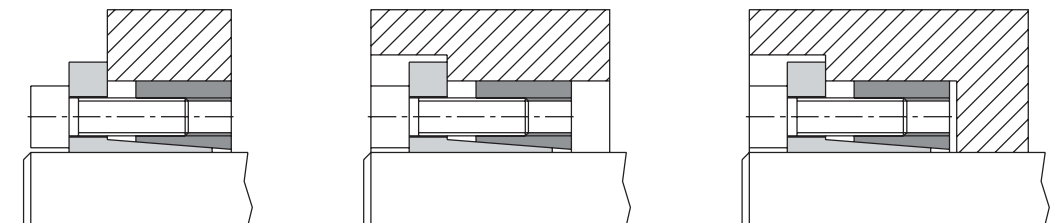

### To fasten one size of hubs on different shaft diameters

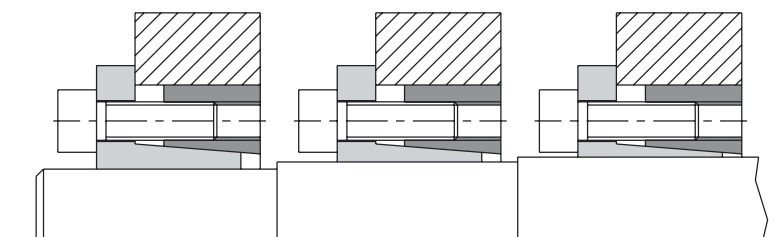

Ordering example:	KTR 225	28	x	65
	Series	Size of internal diameter d		Size of external diameter D

CLAMPEX® – KTR 225															
d x D [mm]	Dimensions [mm]					Clamping screws DIN EN ISO 4762 - 12.9 $\mu_{\text{total}}=0.14$				Transmittable torque or axial force		Surface pressure between clamping element		Weight [~kg]	Stock programme
	B	B <sub>1</sub>	B <sub>2</sub>	B <sub>3</sub>	D <sub>1</sub>	M	Length	z = number	T <sub>A</sub> <sup>1)</sup> [Nm]	T [Nm]	F <sub>ax</sub> [kN]	Shaft P <sub>W</sub> [N/mm <sup>2</sup> ]	Hub P <sub>N</sub> [N/mm <sup>2</sup> ]		
14 x 55	38	30	22	17	62	M8	25	4	41	287	41	457	116	0.5	●
16 x 55	38	30	22	17	62	M8	25	4	41	329	41	401	117	0.5	●
18 x 55	38	30	22	17	62	M8	25	4	41	370	41	356	117	0.5	●
19 x 55	38	30	22	17	62	M8	25	4	41	390	41	337	116	0.5	●
20 x 55	38	30	22	17	62	M8	25	4	41	410	41	320	116	0.5	●
22 x 55	38	30	22	17	62	M8	25	4	41	451	41	291	116	0.5	●
24 x 55	38	30	22	17	62	M8	25	4	41	492	41	267	116	0.4	●
25 x 55	38	30	22	17	62	M8	25	4	41	513	41	256	116	0.4	●
28 x 55	38	30	22	17	62	M8	25	4	41	575	41	229	117	0.4	●
30 x 55	38	30	22	17	62	M8	25	4	41	616	41	214	117	0.4	●
24 x 65	38	30	22	17	72	M8	25	5	41	616	51	334	123	0.7	●
25 x 65	38	30	22	17	72	M8	25	5	41	641	51	320	123	0.7	●
28 x 65	38	30	22	17	72	M8	25	5	41	718	51	286	123	0.6	●
30 x 65	38	30	22	17	72	M8	25	5	41	770	51	267	123	0.6	●
32 x 65	38	30	22	17	72	M8	25	5	41	821	51	250	123	0.6	●
35 x 65	38	30	22	17	72	M8	25	5	41	898	51	229	123	0.5	●
38 x 65	38	30	22	17	72	M8	25	5	41	975	51	211	123	0.5	●
40 x 65	38	30	22	17	72	M8	25	5	41	1026	51	200	123	0.5	●
30 x 80	41	33	25	20	88	M8	25	7	41	1077	72	317	119	1.1	
32 x 80	41	33	25	20	88	M8	25	7	41	1150	72	298	119	1.1	
35 x 80	41	33	25	20	88	M8	25	7	41	1257	72	272	119	1.0	
38 x 80	41	33	25	20	88	M8	25	7	41	1364	72	251	119	1.0	
40 x 80	41	33	25	20	88	M8	25	7	41	1436	72	238	119	0.9	●
42 x 80	41	33	25	20	88	M8	25	7	41	1509	72	227	119	0.9	
45 x 80	41	33	25	20	88	M8	25	7	41	1616	72	212	119	0.9	
48 x 80	41	33	25	20	88	M8	25	7	41	1723	72	198	119	0.8	
50 x 80	41	33	25	20	88	M8	25	7	41	1796	72	191	119	0.8	●

● Sizes of clamping elements available from stock.

<sup>1)</sup> These are the maximum screw tightening torques. They can be reduced by a maximum of 40 % of the above-mentioned figures with T, F<sub>ax</sub>, P<sub>W</sub> and P<sub>N</sub> decreasing proportionately.

# CLAMPEX® KTR 250

## Clamping elements

Self-centering clamping element, particularly suitable for thin-walled hubs

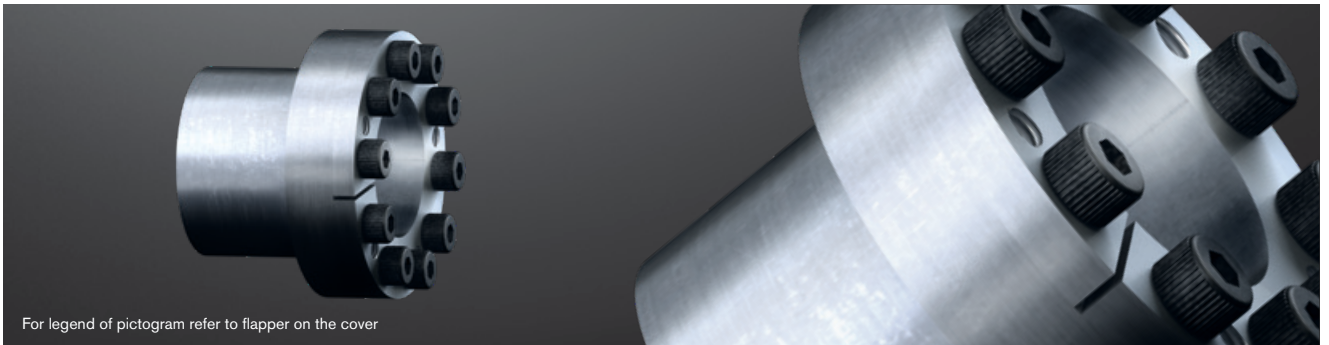

For legend of pictogram refer to flapper on the cover

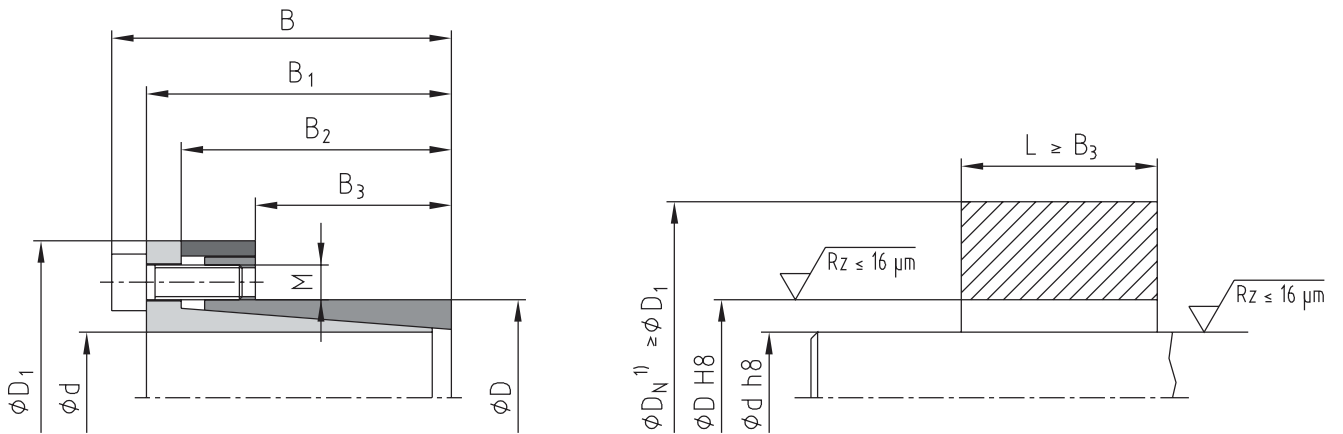

<sup>1)</sup> Dimension  $D_N$ : for calculation see page 297.

### Example of application of hub type

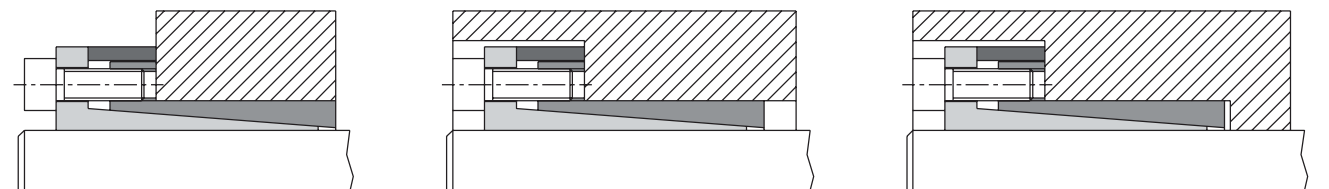

Ordering example:	KTR 250	28	x	39
	Series	Size of internal diameter d		Size of external diameter D

CLAMPEX® – KTR 250															
d x D [mm]	Dimensions [mm]					Clamping screws DIN EN ISO 4762 - 12.9 $\mu_{total}=0.14$				Transmittable torque or axial force		Surface pressure be- tween clamping element		Weight [~kg]	Stock pro- gramme
	B	B <sub>1</sub>	B <sub>2</sub>	B <sub>3</sub>	D <sub>1</sub>	M	Length	z = number	T <sub>A</sub> [Nm] <sup>1)</sup>	T [Nm]	F <sub>ax</sub> [kN]	Shaft P <sub>W</sub> [N/mm <sup>2</sup> ]	Hub P <sub>N</sub> [N/ mm <sup>2</sup> ]		
6 x 14	24.5	21.5	18.5	10	25	M3	10	4	2.6	11	4	162	69	0.05	●
8 x 15	29	25	21.5	11.5	27	M4	10	3	5.6	26	7	187	100	0.05	●
9 x 16	30	26	22.5	14	28	M4	10	4	5.6	37	8	173	97	0.06	●
10 x 16	30	26	22.5	14	29	M4	10	4	5.6	42	8	159	99	0.16	●
11 x 18	30	26	22.5	13.5	32	M4	10	4	5.6	50	9	162	99	0.18	●
12 x 18	30	26	22.5	13.5	32	M4	10	4	5.6	55	9	150	100	0.18	●
14 x 23	30	26	22.5	14	38	M4	10	6	5.6	100	14	193	118	0.20	●
15 x 24	42	36	28.5	16	44	M6	18	4	15	145	19	214	134	0.2	●
16 x 24	42	36	28.5	16	44	M6	18	4	15	155	19	201	134	0.3	●
17 x 25	42	36	28.5	16	45	M6	18	4	15	162	19	186	126	0.2	●
17 x 26	44	38	31	18	47	M6	18	4	17	180	21	184	120	0.2	●
18 x 26	44	38	31	18	47	M6	18	4	17	200	22	182	126	0.2	●
19 x 27	44	38	31	18	48	M6	18	4	17	210	22	171	121	0.3	●
20 x 28	44	38	31	18	49	M6	18	4	17	220	22	162	116	0.2	●
22 x 32	51	45	38	25	54	M6	18	4	17	250	23	110	75	0.3	●
24 x 34	51	45	38	25	56	M6	18	4	17	270	23	99	70	0.3	●
25 x 34	51	45	38	25	56	M6	18	4	17	280	22	95	70	0.3	●
28 x 39	51	45	38	25	61	M6	18	6	17	480	34	130	93	0.4	●
30 x 41	51	45	38	25	62	M6	18	6	17	510	34	120	88	0.4	●
32 x 43	51	45	38	25	65	M6	18	8	17	730	46	151	113	0.5	●
35 x 47	56	50	43	30	69	M6	18	8	17	800	46	115	86	0.5	●
38 x 50	56	50	43	30	72	M6	18	8	17	860	45	105	80	0.6	●
40 x 53	56	50	43	30	75	M6	18	8	17	900	45	99	75	0.6	●
42 x 55	65	57	49	32	78	M8	22	8	41	1800	86	169	129	0.9	●
45 x 59	73	65	57	40	85	M8	22	8	41	1900	84	124	95	1.0	●
48 x 62	78	70	62	45	87	M8	22	8	41	2000	83	102	79	1.0	●
50 x 65	78	70	62	45	92	M8	22	10	41	2600	104	123	94	1.3	●
55 x 71	83	75	67	50	98	M8	22	10	41	2900	105	102	79	1.5	●
60 x 77	83	75	67	50	104	M8	22	10	41	3100	103	91	71	1.7	●
65 x 84	83	75	67	50	111	M8	22	10	41	3400	105	85	66	1.9	●
70 x 90	101	91	80	60	119	M10	25	10	83	5800	166	105	81	2.9	●
75 x 95	101	91	80	60	126	M10	25	10	83	6200	165	97	77	2.3	●
80 x 100	106	96	85	65	131	M10	25	12	83	8000	200	102	82	3.3	●
85 x 106	106	96	85	65	137	M10	25	12	83	8500	200	96	77	3.6	●
90 x 112	106	96	85	65	143	M10	25	15	83	11200	249	113	91	3.9	●
95 x 120	106	96	85	65	153	M10	25	15	83	11800	248	107	84	4.5	●
100 x 125	114	102	89	65	162	M12	30	12	145	14600	292	119	95	5.5	●
110 x 140	140	128	114	90	180	M12	30	12	145	16000	291	78	61	8.0	●
120 x 155	140	128	114	90	198	M12	30	12	145	17400	290	71	55	10.5	●
130 x 165	140	128	114	90	208	M12	30	16	145	25000	385	87	69	11.9	●

● Sizes of clamping elements available from stock.

<sup>1)</sup> These are the maximum screw tightening torques. They can be reduced by a maximum of 40 % of the above-mentioned figures with T, F<sub>ax</sub>, P<sub>W</sub> and P<sub>N</sub> decreasing proportionately.

# CLAMPEX® KTR 400

## Clamping elements

Self-centering clamping element with highest transmission performance

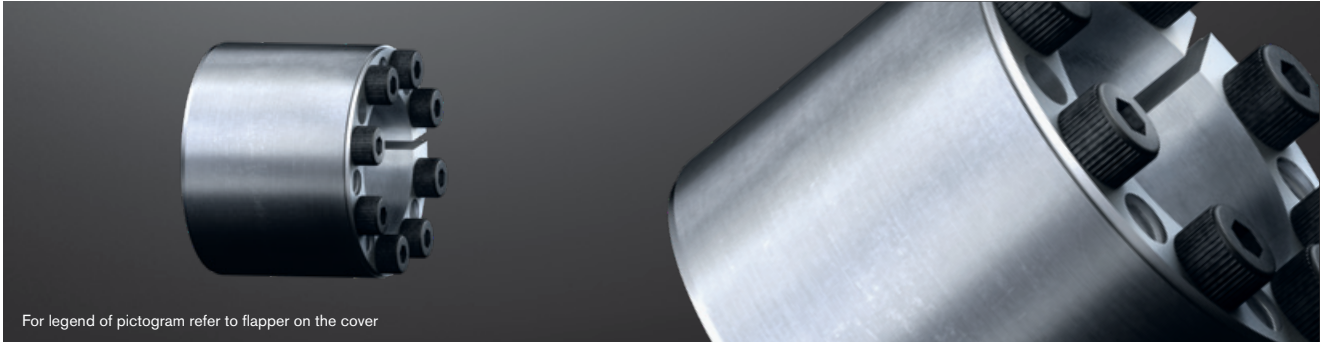

For legend of pictogram refer to flapper on the cover

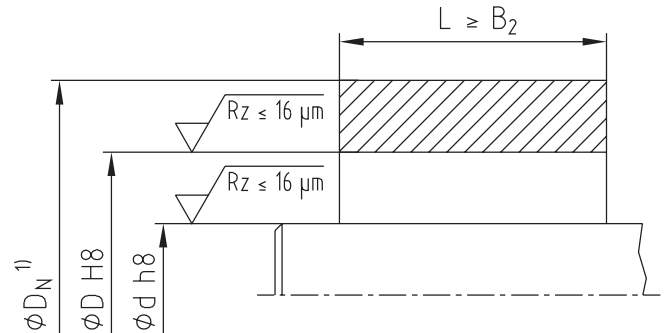
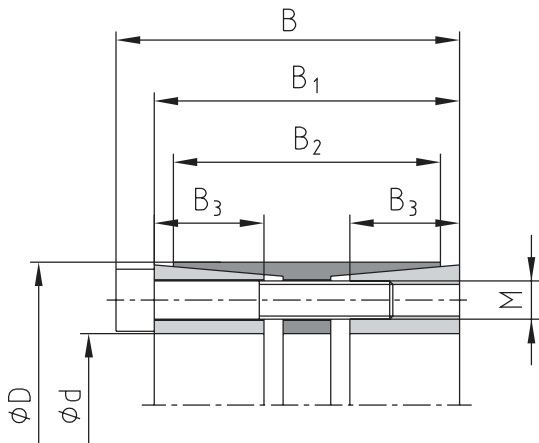

<sup>1)</sup> Dimension DN: for calculation see page 297.

### Example of application of hub type

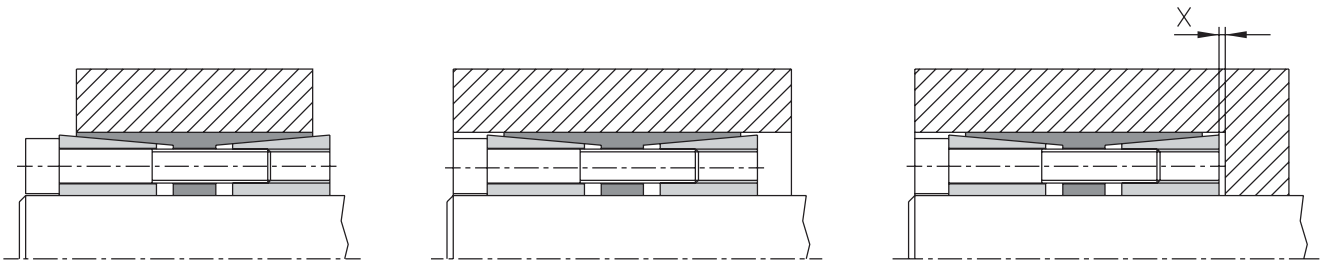

Formula to calculate space x for disassembly:

$$x = \frac{B_1 - B_2}{2}$$

Ordering example:	KTR 400	100	x	145
	Series	Size of internal diameter d		Size of external diameter D

**CLAMPEX® – KTR 400**

d x D <sup>1)</sup> [mm]	Dimensions [mm]				Standard applications in industry								Applications with components subjected to bending and torsion stress								Weight [-kg]	Stock programme	
					Clamping screws DIN EN ISO 4762 - 12.9 μ <sub>total</sub> =0.14				Transmittable torque or axial force		Surface pressure between clamp- ing element		Clamping screws DIN EN ISO 4762 - 12.9 μ <sub>total</sub> =0.14				Transmittable torque or axial force		Transmit- table bending moment				Surface pressure between clamp- ing element
	B	B <sub>1</sub>	B <sub>2</sub>	B <sub>3</sub>	M	z = num- ber	Length	T <sub>A</sub> <sup>2)</sup> [Nm]	T [Nm]	F <sub>ax</sub> [kN]	Shaft P <sub>W</sub> [N/mm <sup>2</sup> ]	Hub P <sub>N</sub> [N/mm <sup>2</sup> ]	M	z = num- ber	Length	T <sub>A</sub> [Nm]	T [Nm]	F <sub>ax</sub> [kN]	M <sub>b</sub> perm. [Nm]	Shaft P <sub>W</sub> [N/mm <sup>2</sup> ]			Hub P <sub>N</sub> [N/mm <sup>2</sup> ]
24 x 50	51	45	41	16	M6	6	35	17	700	58	202	92	M6	6	35	14	460	38	420	230	93	0.5	●
25 x 50	51	45	41	16	M6	6	35	17	730	58	194	92	M6	6	35	14	470	38	430	222	94	0.5	●
28 x 55	51	45	41	16	M6	8	35	17	1100	79	233	112	M6	8	35	14	740	53	490	257	110	0.5	●
30 x 55	51	45	41	16	M6	8	35	17	1180	79	217	112	M6	8	35	14	790	53	520	243	112	0.5	●
32 x 60	51	45	41	16	M6	8	35	17	1270	79	206	103	M6	8	35	14	830	52	560	230	104	0.8	●
35 x 60	51	45	41	16	M6	8	35	17	1390	79	188	104	M6	8	35	14	890	51	610	214	106	0.7	●
38 x 65	51	45	41	16	M6	10	35	17	1880	99	216	119	M6	10	35	14	1250	66	660	240	119	1.1	●
40 x 65	51	45	41	16	M6	10	35	17	1980	99	205	119	M6	10	35	14	1300	65	700	230	120	1.1	●
40 x 75	51	45	41	16	M8	8	35	41	2850	143	296	149	M8	8	35	35	2030	102	700	320	142	1.1	●
42 x 75	51	45	41	16	M8	8	35	41	3000	143	282	149	M8	8	35	35	2120	101	730	307	142	1.2	●
45 x 75	51	45	41	16	M8	8	35	41	3250	144	266	151	M8	8	35	35	2260	100	780	289	145	1.1	●
48 x 80	70	62	58	23	M8	8	55	41	3450	144	173	98	M8	8	55	35	2160	90	1700	202	101	1.5	●
50 x 80	70	62	58	23	M8	8	55	41	3600	144	166	98	M8	8	55	35	2220	89	1770	196	102	1.4	●
55 x 85	70	62	58	23	M8	8	55	41	3950	144	151	92	M8	8	55	35	2350	85	1950	182	98	1.5	●
60 x 90	70	62	58	23	M8	10	55	41	5400	180	173	109	M8	10	55	35	3380	113	2130	202	113	1.6	●
65 x 95	70	62	58	23	M8	10	55	41	5850	180	160	103	M8	10	55	35	3560	110	2310	190	109	1.7	●
70 x 110	86	76	70	28	M10	10	60	83	10200	291	197	118	M10	10	60	69	6620	189	3650	222	120	3.1	●
75 x 115	86	76	70	28	M10	10	60	83	10950	292	184	113	M10	10	60	69	6970	186	3920	210	117	3.3	●
80 x 120	86	76	70	28	M10	12	60	83	14000	350	207	130	M10	12	60	69	9210	230	4180	231	131	3.5	●
85 x 125	86	76	70	28	M10	12	60	83	15000	353	197	126	M10	12	60	69	9710	228	4440	220	129	3.6	●
90 x 130	86	76	70	28	M10	12	60	83	15800	351	185	121	M10	12	60	69	10000	222	4700	210	124	3.8	●
95 x 135	86	76	70	28	M10	12	60	83	16800	354	176	117	M10	12	60	69	10500	221	4960	201	122	4.0	●
100 x 145	110	98	92	35	M12	12	80	145	26000	520	197	121	M12	12	80	120	16850	337	8580	219	124	6.1	●
110 x 155	110	98	92	35	M12	12	80	145	28600	520	179	114	M12	12	80	120	18000	327	9440	203	118	6.6	●
120 x 165	110	98	92	35	M12	14	80	145	36300	605	191	124	M12	14	80	120	23350	389	10300	214	128	7.1	●
130 x 180	128	114	108	41	M14	12	90	230	46000	708	176	114	M14	12	90	190	29950	461	15300	201	119	10.0	●
140 x 190	128	114	108	41	M14	14	90	230	57800	826	191	126	M14	14	90	190	37200	531	16500	214	129	10.6	●
150 x 200	128	114	108	41	M14	16	90	230	70800	944	204	136	M14	16	90	190	46400	619	17700	226	139	11.2	●
160 x 210	128	114	108	41	M14	16	90	230	75500	944	191	130	M14	16	90	190	48600	608	18800	214	133	11.9	●
170 x 225	162	146	136	52	M16	14	110	355	95900	1128	169	114	M16	14	110	295	59100	695	32000	196	119	17.6	●
180 x 235	162	146	136	52	M16	15	110	355	108800	1209	171	117	M16	15	110	295	67500	750	33900	198	122	18.5	●
190 x 250	162	146	136	52	M16	16	110	355	122500	1289	173	117	M16	16	110	295	76100	801	35800	199	122	21.4	●
200 x 260	162	146	136	52	M16	16	110	355	128900	1289	164	113	M16	16	110	295	78600	786	37700	192	118	22.4	●
220 x 285	162	146	136	52	M16	18	110	355	171800	1562	181	120	M16	18	110	295	105000	955	41400	195	126	26.6	●
240 x 305	162	146	136	52	M16	20	110	355	208000	1733	184	125	M16	20	110	295	128000	1067	45200	198	130	28.7	●
260 x 325	166	150	134	55	M16	21	110	355	237000	1823	169	117	M16	21	110	295	142000	1092	51000	187	123	31.2	●
280 x 355	197	177	165	66	M20	18	130	690	340000	2429	174	119	M20	18	130	580	208000	1486	81300	192	125	46.8	●
300 x 375	197	177	165	66	M20	20	130	690	405000	2700	181	125	M20	20	130	580	252000	1680	87100	198	130	69.7	●
320 x 405	197	177	165	66	M20	21	130	690	453000	2831	178	121	M20	21	130	580	280000	1750	92900	196	127	60.5	●
340 x 425	197	177	165	66	M20	22	130	690	504900	2970	176	121	M20	22	130	580	311000	1829	98700	193	127	63.9	●
360 x 455	224	203	190	76	M22	21	150	930	626000	3478	169	115	M22	21	150	780	381000	2117	138500	189	121	86.8	●
380 x 475	224	203	190	76	M22	22	150	930	692000	3642	167	115	M22	22	150	780	420000	2211	146000	188	122	91.0	●
400 x 495	224	203	190	76	M22	24	150	930	795000	3975	173	121	M22	24	150	780	489000	2445	154000	194	127	95.3	●
420 x 515	224	203	190	76	M22	24	150	930	835000	3976	165	116	M22	24	150	780	505000	2405	161500	186	123	100	●
440 x 535	224	203	190	76	M22	24	150	930	875000	3977	158	112	M22	24	150	780	517000	2350	169000	178	120	105	●
460 x 555	224	203	190	76	M22	24	150	930	914000	3974	151	108	M22	24	150	780	530000	2304	177000	172	117	109	●
480 x 575	224	203	190	76	M22	28	150	930	1113000	4638	169	121	M22	28	150	780	678000	2825	184500	189	128	114	●
500 x 595	224	203	190	76	M22	28	150	930	1160000	4640	162	117	M22	28	150	780	692000	2768	192000	182	125	119	●
520 x 615	224	203	190	76	M22	30	150	930	1292000	4969	167	122	M22	30	150	780	780000	3000	200000	186	129	122.5	●
540 x 635	224	203	190	76	M22	30	150	930	1342000	4970	161	118	M22	30	150	780	799000	2959	207500	180	126	128	●
560 x 655	224	203	190	76	M22	32	150	930	1484000	5300	165	122	M22	32	150	780	893000	3189	215500	184	129	131	●
580 x 675	224	203	190	76	M22	32	150	930	1537000	5300	159	118	M22	32	150	780	912000	3145	223000	179	127	136	●
600 x 695	224	203	190	76	M22	33	150	930	1640000	5467	159	118	M22	33	150	780	972000	3240	231000	179	127	139	●

● Sizes of clamping elements available from stock.

<sup>1)</sup> External ring without slot from size 400 x 495.

<sup>2)</sup> These are the maximum screw tightening torques. They can be reduced by a maximum of 40 % of the above-mentioned figures with T, F<sub>ax</sub>, P<sub>W</sub> and P<sub>N</sub> decreasing proportionately.

# CLAMPEX® KTR 603

## Clamping elements

Three-part external clamping set for applications on hollow shafts



For legend of pictogram refer to flapper on the cover

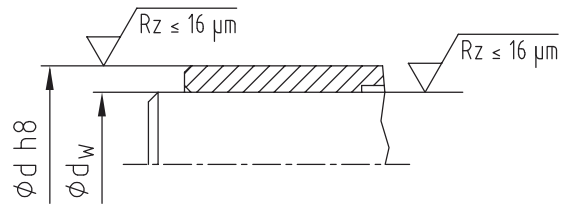
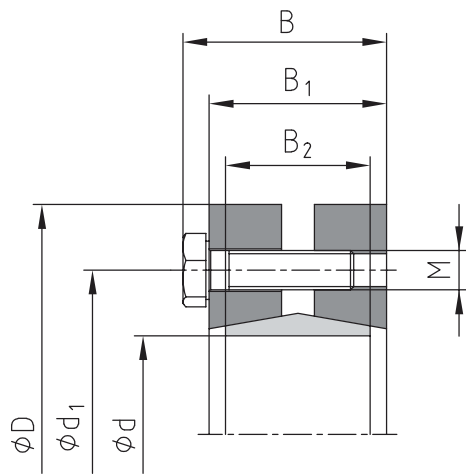

### Tolerances for $d_w$

- For  $d_w$  from 10 to 30 mm     **H6 / j6**
- For  $d_w$  from 31 to 50 mm     **H6 / h6**
- For  $d_w$  from 51 to 80 mm     **H6 / g6**
- For  $d_w$  from 81 to 500 mm    **H7 / g6**

### Example of application of hub type

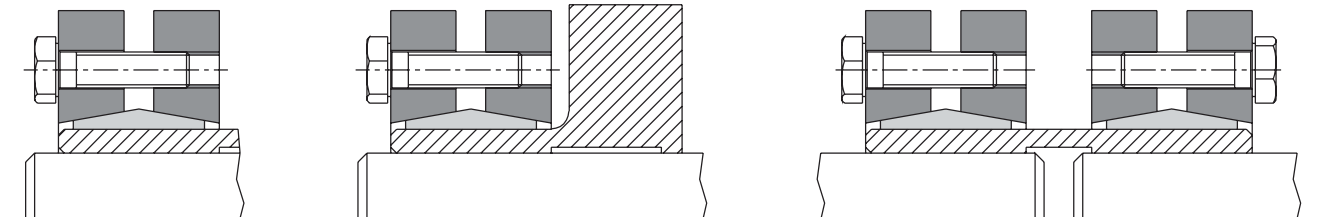

<b>Ordering example:</b>	KTR 603	44	x	80
	Series	Size of internal diameter d		Size of external diameter D

**CLAMPEX® – KTR 603**

d x D [mm]	Shaft diameter d <sub>w</sub> [mm]	Transmittable torque or axial force		Dimensions [mm]				Clamping screws DIN EN ISO 4014 - 10.9 μ <sub>total</sub> =0.10				Surface pressure of clamping element/hollow shaft	Weight [~kg]	Stock programme	
		T [Nm]	F <sub>ax</sub> [kN]	B	B <sub>1</sub>	B <sub>2</sub>	d <sub>1</sub>	M	Length	z = number	T <sub>A</sub> [Nm]	P <sub>H</sub> [N/mm <sup>2</sup> ]			
14 x 38	10	28	6												
	11	38	7	14.5	11	9	24	M5	10	4	3.5	388	0.1	●	
	12	50	8												
16 x 41	12	50	8												
	13	70	11	18.5	15	11	26	M5	14	5	4	310	0.2	●	
	14	90	13												
24 x 50	19	180	19												
	20	210	21	22.5	19	14	36	M5	18	6	5	286	0.2	●	
	21	250	24												
30 x 60	24	310	26												
	25	340	27	24.5	21	16	44	M5	18	6	6	233	0.3	●	
	26	380	29												
36 x 72	28	460	33												
	30	590	39	27	23	18	52	M6	20	5	12	307	0.4	●	
	31	630	41												
44 x 80	32	630	39												
	35	780	45	29	25	20	61	M6	22	7	12	317	0.6	●	
	36	860	48												
50 x 90	38	940	49												
	40	1100	55	31	27	22	70	M6	22	8	12	289	0.8	●	
	42	1300	62												
55 x 100	42	1200	57												
	45	1500	67	34	30	23	75	M6	25	8	12	252	1.1	●	
	48	1900	79												
62 x 110	48	1800	75												
	50	2200	88	34	30	23	86	M6	25	10	12	279	1.3	●	
	52	2400	92												
68 x 115	50	2000	80												
	55	2500	91	34	30	23	86	M6	25	10	12	255	1.4	●	
	60	3100	103												
75 x 138	55	2500	91												
	60	3200	107	37.5	32	25	100	M8	30	7	30	273	1.8	●	
	65	3900	120												
80 x 145	60	3200	107												
	65	3900	120	37.5	32	25	100	M8	30	7	30	256	2.6	●	
	70	4600	131												
85 x 155	65	4800	148												
	70	6100	174	44.5	39	30	114	M8	35	10	30	285	3.9		
	75	7400	197												
90 x 155	65	4700	145												
	70	6000	171	44.5	39	30	114	M8	35	10	30	217	3.8	●	
	75	7200	192												
100 x 170	70	6900	197												
	75	7500	200	49.5	44	34	124	M8	35	12	30	227	4.7	●	
	80	9000	225												
110 x 185	75	7200	192												
	80	9000	225	56.5	50	39	136	M10	40	9	59	215	6.0	●	
	85	11000	259												
115 x 188	80	8500	213												
	85	10000	235	56.5	50	39	141	M10	40	9	59	209	5.0		
	90	12000	267												
120 x 215	80	10500	263												
	85	13200	311	58.5	52	42	160	M10	40	12	59	271	5.9		
	90	14400	320												
125 x 215	85	11000	259												
	90	13000	289	58.5	52	42	160	M10	40	12	59	222	8.5	●	
	95	15000	316												
130 x 215	90	13700	304												
	95	15800	333	58.5	52	42	160	M10	40	12	59	227	9.0		
	100	18200	364												
140 x 230	95	15000	316												
	100	17000	340	67.5	60	46	175	M12	45	10	100	209	11		
	105	20000	381												

● Sizes of clamping elements available from stock.  
Other sizes on request.

# CLAMPEX® KTR 603

## Clamping elements

Three-part external clamping set for applications on hollow shafts

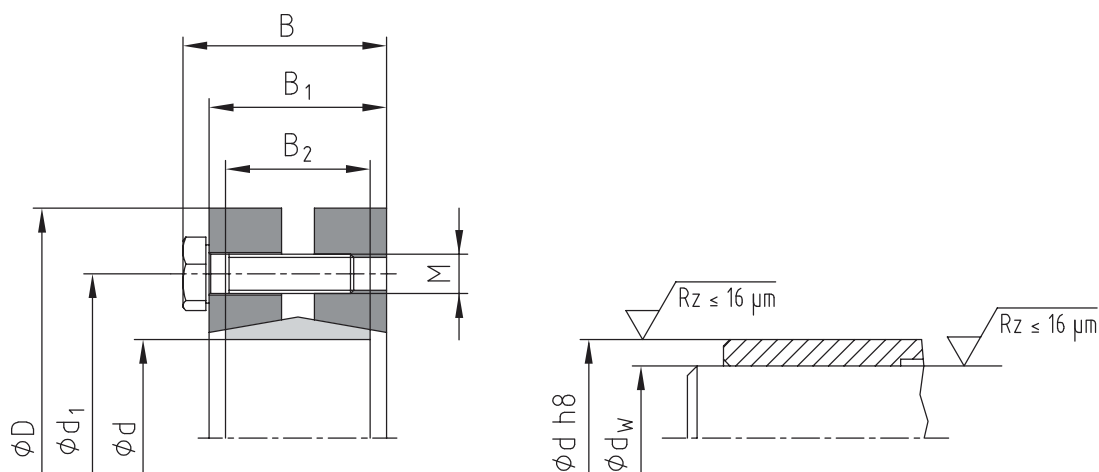

CLAMPEX® – KTR 603														
d x D [mm]	Shaft diameter d <sub>w</sub> [mm]	Transmittable torque or axial force		Dimensions [mm]				Clamping screws DIN EN ISO 4014 - 10.9 μ <sub>total</sub> =0.10				Surface pressure of clamping element/hollow shaft	Weight [~kg]	Stock programme
		T [Nm]	F <sub>ax</sub> [kN]	B	B <sub>1</sub>	B <sub>2</sub>	d <sub>1</sub>	M	Length	z = number	T <sub>A</sub> [Nm]	P <sub>H</sub> [N/mm <sup>2</sup> ]		
155 x 265	105	20000	381	71.5	64	50	192	M12	50	12	100	212	15	
	110	23000	418											
	115	26000	452											
160 x 265	110	22500	409	71.5	64	50	192	M12	50	12	100	204	14	
	115	25500	443											
	120	28600	477											
165 x 290	115	36000	626	81	71	56	210	M16	60	8	250	269	24	
	120	39000	650											
	125	44000	704											
170 x 290	120	31700	528	81	71	56	210	M16	60	8	250	216	24	
	125	35800	573											
	130	40000	615											
175 x 300	125	40000	640	81	71	56	220	M16	60	8	250	253	16	
	130	44000	677											
	135	49000	726											
180 x 300	130	36800	566	81	71	56	220	M16	60	8	250	211	16	
	135	42000	622											
	140	46000	657											
185 x 330	135	55000	815	96	86	71	236	M16	65	10	250	231	35	
	140	60000	857											
	145	65000	897											
190 x 330	140	53300	761	96	86	71	236	M16	65	10	250	201	35	
	145	58500	807											
	150	63500	847											
195 x 350	140	66000	943	96	86	71	246	M16	65	12	250	259	38	
	150	76000	1013											
	155	82000	1058											
200 x 350	150	73700	983	96	86	71	246	M16	65	12	250	240	41	
	155	79800	1030											
	160	85800	1073											
220 x 370	160	95000	1188	114	104	88	270	M16	80	15	250	216	54	
	165	102000	1236											
	170	110000	1294											
240 x 405	170	120000	1412	121.5	109	92	295	M20	80	12	490	239	67	
	180	140000	1556											
	190	160000	1684											
250 x 405	180	160000	1778	120.5	108	92	295	M20	85	14	490	263	64	
	190	180000	1895											
	200	200000	2000											
260 x 430	190	165000	1737	132.5	120	103	321	M20	90	14	490	225	82	
	200	185000	1850											
	210	204000	1943											

● Sizes of clamping elements available from stock.  
Other sizes on request.

CLAMPEX® – KTR 603														
d x D [mm]	Shaft diameter d <sub>w</sub> [mm]	Transmittable torque or axial force		Dimensions [mm]				Clamping screws DIN EN ISO 4014 - 10.9 P <sub>total</sub> =0.10				Surface pressure of clamping element/hollow shaft	Weight [-kg]	Stock programme
		T [Nm]	F <sub>ax</sub> [kN]	B	B <sub>1</sub>	B <sub>2</sub>	d <sub>1</sub>	M	Length	z = number	T <sub>A</sub> [Nm]	P <sub>H</sub> [N/mm <sup>2</sup> ]		
280 x 460	210	216000	2057											
	220	245000	2227	146.5	134	114	346	M20	100	16	490	217	102	
	230	270000	2348											
300 x 485	230	274000	2383											
	240	296000	2467	154.5	142	122	364	M20	100	18	490	209	118	
	245	316000	2580											
320 x 520	240	311000	2592											
	250	340000	2720	154.5	142	122	386	M20	100	20	490	219	131	
	260	375000	2885											
330 x 520	250	352000	2816											
	260	385000	2962	154.5	142	122	386	M20	100	22	490	224	126.1	
	270	420000	3111											
340 x 570	250	389000	3112											
	260	422000	3246	168.5	156	134	408	M20	110	24	490	227	186	
	270	459000	3400											
350 x 580	270	443000	3281											
	280	480000	3429	174.5	162	140	432	M20	110	24	490	212	195	
	285	500000	3509											
360 x 590	280	462000	3300											
	290	500000	3448	174.5	162	140	432	M20	110	24	490	204	204	
	300	530000	3533											
380 x 645	290	570000	3931											
	300	610000	4067	183	168	144	458	M24	120	20	840	224	239	
	310	660000	4258											
390 x 660	300	625000	4167											
	310	670000	4323	183	168	144	468	M24	120	21	840	229	260	
	320	720000	4500											
400 x 680	315	671000	4260											
	320	695000	4344	183	168	144	480	M24	120	21	840	222	280	
	330	745000	4515											
420 x 690	330	782000	4739											
	340	841000	4947	203	188	164	504	M24	130	24	840	211	316	
	350	902000	5154											
440 x 750	340	805000	4735											
	350	861000	4920	217	202	177	527	M24	140	24	840	190	408	
	360	920000	5111											
460 x 770	360	1000000	5556											
	370	1073000	5800	217	202	177	547	M24	140	28	840	210	420	
	380	1141000	6005											
480 x 800	380	1175000	6184											
	390	1250000	6410	228	213	188	570	M24	140	30	840	206	505	
	400	1312000	6560											
500 x 850	400	1314000	6570											
	410	1382000	6741	230	213	188	590	M27	150	24	1250	205	575	
	420	1460000	6952											

● Sizes of clamping elements available from stock.  
Other sizes on request.

# CLAMPEX® KTR 620

## Clamping elements

Two-part external clamping set for applications on hollow shafts



For legend of pictogram refer to flapper on the cover

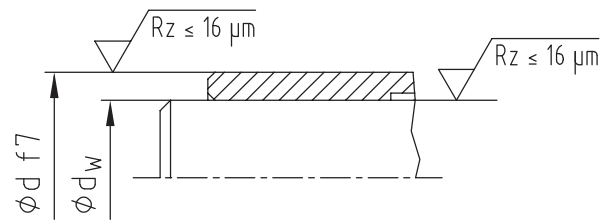
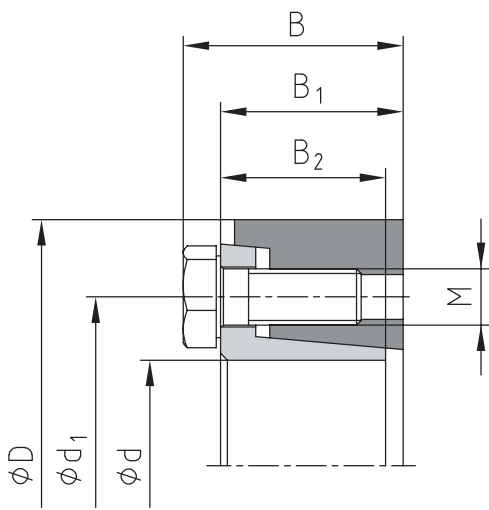

### Tolerances for $d_w$

- $d_w \leq \phi 160 = h6/H7$
- $d_w > \phi 160 = g6/H7$

### Example of application of hub type

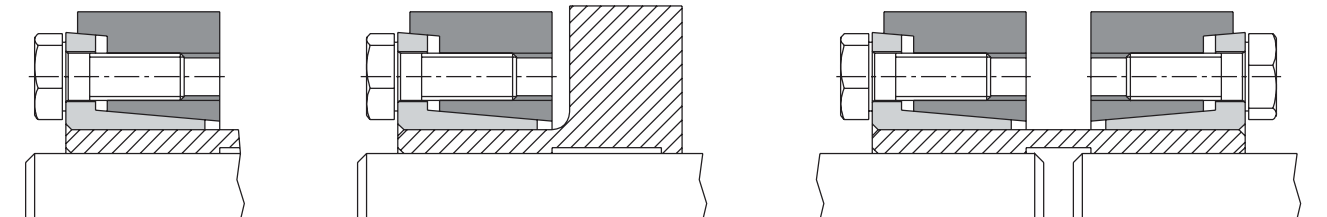

Ordering example:	KTR 620	55	x	100
	Series	Size of internal diameter d		Size of external diameter D

CLAMPEX® – KTR 620

d x D [mm]	Shaft diameter d <sub>w</sub> [mm]	Transmittable torque or axial force		Dimensions [mm]				Clamping screws DIN EN ISO 4017 - 12.9 <sup>1)</sup> μ <sub>total</sub> =0.10				Surface pressure of clamping element/hollow shaft P <sub>H</sub> [N/mm <sup>2</sup> ]	Weight [-kg]	Stock programme
		T [Nm]	F <sub>ax</sub> [kN]	B	B <sub>1</sub>	B <sub>2</sub>	d <sub>1</sub>	M	Length	z = number	T <sub>A</sub> [Nm]			
16 x 41	13	70	11	19.5	15.3	13.5	28	M6	12	3	13	254	0.1	
	14	90	13											
18 x 44	15	80	11	19.5	15.3	13.5	30	M6	12	4	13	222	0.1	
	16	110	14											
20 x 47	17	150	18	19.5	15.3	13.5	32	M6	12	4	13	274	0.1	●
	18	175	19											
24 x 50	19	165	17	22	18.22	16	36	M6	16	5	13	243	0.2	●
	20	215	22											
26 x 51.5	22	280	25	22	18.05	16	38	M6	16	5	13	238	0.2	
	20	200	20											
30 x 60	24	370	31	24	20.26	18	44	M6	16	6	13	255	0.3	●
	25	420	34											
36 x 72	26	465	36	27.5	22.1	20	52	M8	20	5	30	250	0.5	●
	27	480	36											
38 x 72	30	650	43	27.5	22.1	20	54	M8	20	5	30	240	0.5	●
	33	765	46											
40 x 80	34	830	49	29.5	24.22	22	61	M8	20	6	30	209	0.6	●
	35	770	44											
44 x 80	37	880	48	29.5	24.22	22	61	M8	20	6	30	192	0.6	●
	38	1130	59											
50 x 90	40	1260	63	31.5	26.1	23.5	68	M8	20	8	30	212	0.8	●
	42	1400	67											
55 x 100	42	1300	62	34.5	29	26	72	M8	20	8	30	195	1.1	●
	45	1600	71											
60 x 110	48	1900	79	34.5	29.25	26	80	M8	20	9	30	191	1.3	●
	48	1700	71											
62 x 110	50	1950	78	34.5	29.25	26	80	M8	20	9	30	189	1.3	●
	52	2160	83											
68 x 115	50	1900	76	35	29.4	26	86	M8	20	9	30	206	1.3	●
	55	2500	91											
75 x 138	60	3400	113	37.5	30.7	27	100	M10	25	10	60	211	2.3	●
	65	4100	126											
80 x 141	60	3300	110	37.5	31.1	27	104	M10	25	10	60	215	2.3	●
	65	4100	126											
85 x 155	70	6400	183	44.5	38.2	34	114	M10	25	11	60	216	3.2	
	75	7300	195											
90 x 155	65	5500	169	44.5	38.2	34	114	M10	25	11	60	223	3.2	●
	70	6600	189											
95 x 170	75	7900	211	50	43.45	39	124	M10	30	14	60	182	4.3	
	70	6200	177											
100 x 170	75	7400	197	50	43.45	39	124	M10	30	14	60	176	4.3	●
	80	8600	215											
105 x 185	80	10500	263	56.5	49.1	43.5	136	M12	35	12	100	208	5.8	
	85	11800	278											
110 x 185	90	13700	304	56.5	49.1	43.5	136	M12	35	12	100	202	5.8	●
	80	10500	263											
115 x 197	85	12500	294	60.5	53	48	147	M12	35	14	100	193	6.9	
	90	14100	313											
120 x 197	95	16000	337	60.5	53	48	147	M12	35	14	100	189	6.9	
	85	12500	294											
	90	14100	313											
	95	16000	337											

● Sizes of clamping elements available from stock.  
<sup>1)</sup> DIN EN ISO 4017-10.9 for size 16 x 41 to 20 x 47

# CLAMPEX® KTR 620

## Clamping elements

Two-part external clamping set for applications on hollow shafts

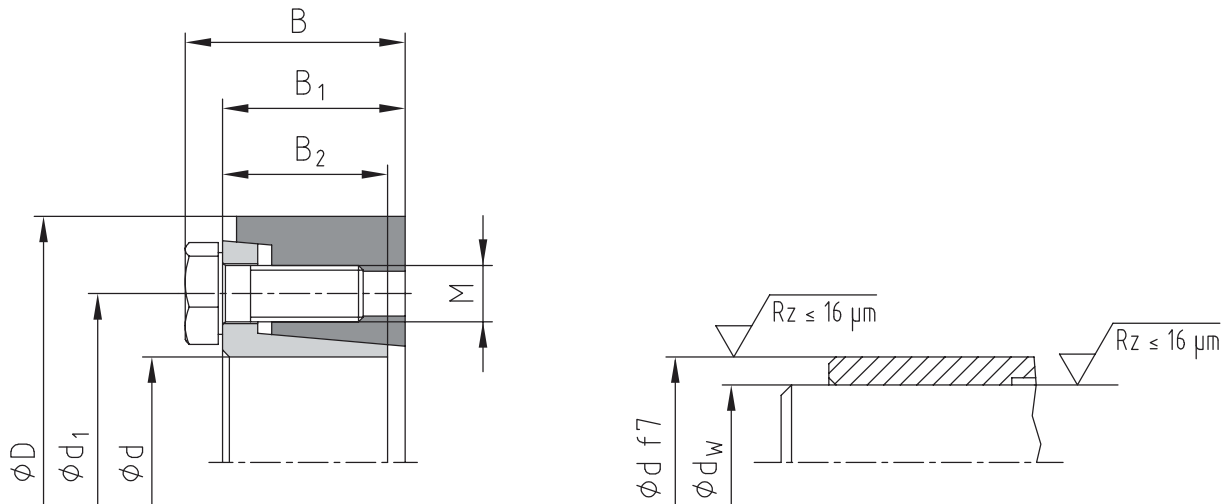

CLAMPEX® – KTR 620

d x D [mm]	Shaft diameter d <sub>w</sub> [mm]	Transmittable torque or axial force		Dimensions [mm]				Clamping screws DIN EN ISO 4017 - 12.9 μ <sub>total</sub> =0.10				Surface pressure of clamping element/hollow shaft P <sub>H</sub> [N/mm <sup>2</sup> ]	Weight [-kg]	Stock programme
		T [Nm]	F <sub>ax</sub> [kN]	B	B <sub>1</sub>	B <sub>2</sub>	d <sub>1</sub>	M	Length	z = number	T <sub>A</sub> [Nm]			
125 x 215	90	14500	322	61	53.4	48	158	M12	35	14	100	196	8.7	●
	95	16600	349											
	100	18800	376											
130 x 215	95	17000	358	61	53.4	48	158	M12	35	14	100	187	9.4	
	100	18400	368											
	110	22000	400											
130 x 230	95	18400	387	66.5	57.5	51	165	M14	40	12	160	213	10.8	●
	100	20800	416											
	110	26200	476											
135x 230	95	18400	387	66.5	57.5	51	165	M14	40	12	160	209	10.8	
	100	20800	416											
	110	26200	476											
140 x 230	100	19900	398	67	57.8	51	172	M14	40	12	160	207	10.3	
	105	22200	423											
	115	27800	483											
150 x 263	110	27000	491	71	62.2	55	186	M14	40	14	160	202	15.2	
	120	32000	533											
	125	36200	579											
155 x 263	110	27000	491	71	62.2	55	186	M14	40	14	160	199	15.2	
	120	32000	533											
	125	36200	579											
160 x 290	120	39000	650	78.5	68.5	61	198	M16	45	12	250	215	21.5	
	130	48000	738											
	135	51000	756											
165 x 290	120	39000	650	78.5	68.5	61	198	M16	45	12	250	212	21.5	
	130	48000	738											
	135	51000	756											
170 x 300	130	46500	715	79	68.9	61	208	M16	50	14	250	212	22.5	
	140	53000	757											
	145	59000	814											
175 x 300	130	46500	715	79	68.9	61	208	M16	50	14	250	209	22.5	●
	140	53000	757											
	145	59000	814											
180 x 320	140	66000	943	95	85	77.5	222	M16	50	16	250	210	32.7	
	150	76000	1013											
	155	83000	1071											
185 x 320	140	66000	943	95	85	77.5	222	M16	50	16	250	207	32.7	
	150	76000	1013											
	155	83000	1071											
190 x 340	150	82000	1093	98	87.7	77.5	238	M16	50	16	250	225	36.3	
	160	91000	1138											
	165	102000	1236											
195 x 340	150	82000	1093	98	87.7	77.5	238	M16	50	16	250	222	36.3	
	160	91000	1138											
	165	102000	1236											
200 x 340	150	82000	1093	98	87.7	77.5	238	M16	50	16	250	219	36.3	
	160	91000	1138											
	165	102000	1236											

● Sizes of clamping elements available from stock.

CLAMPEX® – KTR 620

d x D [mm]	Shaft diameter d <sub>w</sub> [mm]	Transmittable torque or axial force		Dimensions [mm]				Clamping screws DIN EN ISO 4017 - 12.9 <sup>2)</sup> μ <sub>total</sub> =0.10				Surface pressure of clamping element/hollow shaft	Weight [-kg]	Stock programme	
		T [Nm]	F <sub>ax</sub> [kN]	B	B <sub>1</sub>	B <sub>2</sub>	d <sub>1</sub>	M	Length	z = number	T <sub>A</sub> [Nm]	P <sub>H</sub> [N/mm <sup>2</sup> ]			
220 x 370	160	105000	1313												
	170	122000	1435	120	107.55	96.5	268	M20	60	15	480	205	53		
	180	138000	1533												
240 x 405	170	125000	1471												
	180	145000	1611	123.5	111.1	98	288	M20	60	16	480	214	66		
	200	182000	1820												
260 x 430	190	165000	1737												
	200	190000	1900	138	125.3	110.5	312	M20	60	16	480	202	82		
	220	238000	2164												
280 x 460	210	220000	2095												
	220	245000	2227	152.5	140	121	334	M20	60	18	480	193	103		
	240	300000	2500												
300 x 485	220	297000	2700												
	230	330000	2870	159	139.8	124	360	M24	70	16	840	205	120		
	250	399000	3192												
320 x 520	240	331000	2758												
	250	365000	2920	160.5	141.6	124	380	M24	70	18	840	190	138		
	270	437000	3237												
340 x 570	250	429000	3432												
	260	469000	3608	177.5	158.4	139	402	M24	70	18	840	195	189		
	280	556000	3971												
360 x 590	270	545000	4037												
	280	592000	4229	182	163	143	424	M24	70	20	840	216	207		
	290	694000	4786												
390 x 650	290	704000	4855												
	300	760000	5067	191	169.2	148	454	M27	70	18	1250	216	249		
	320	879000	5494												
420 x 670	320	827000	5169												
	330	876000	5309	208.4	186.4	166	486	M27	70	20	1250	184	285		
	350	1000000	5714												
440 x 710	340	1117000	6571												
	350	1190000	6800	220	198	179	506	M27	70	21	1250	222	343		
	370	1345000	7270												
460 x 750	360	1306000	7256												
	370	1386000	7492	223	201	179	534	M27	70	21	1250	230	387		
	390	1554000	7969												
470 x 705	370	950000	5135												
	380	1000000	5263	241.6	219.6	200	538	M27	70	21	1250	151	340		
	400	1150000	5750												
480 x 770	380	1557000	8195												
	390	1648000	8451	247	223	201	552	M30	100	21	1650	223	449		
	410	1818000	8868												
500 x 820	400	1653000	8265												
	410	1725000	8415	241	217	198	572	M30	100	24	1650	214	515		
	430	1915000	8907												
530 x 850	430	2048000	9526												
	440	2154000	9791	262.3	238.3	216	606.5	M30	100	24	1650	208	585		
	460	2374000	10322												
560 x 885	450	2306000	10249												
	460	2419000	10517	266	242	220	632	M30	100	24	1650	212	636		
	480	2654000	11058												
590 x 950	470	2735000	11638												
	480	2863000	11929	281.5	257.5	236	664	M30	100	28	1650	211	805		
	500	3128000	12512												
620 x 960	500	3150000	12600												
	520	3396000	13062	307	283	258	706	M30	100	28	1650	201	853		
	540	3689000	13663												
660 x 1020	530	3636000	13721												
	550	3942000	14335	319	293	267	748	M33	130	28	2250	199	993		
	570	4261000	14951												
700 x 1085	560	4189000	14961												
	580	4520000	15586	318.5	292.5	263	788	M33	130	28	2250	187	1112		
	600	4863000	16210												
750 x 1100	600	5281000	17603												
	620	5672000	18297	346	320	280	850	M33	130	32	2250	202	1111		
	650	6287000	19345												
800 x 1230	640	6091000	19034												
	660	6511000	19730	359	333	296	900	M33	130	32	2250	202	1589		
	700	7394000	21126												

● Sizes of clamping elements available from stock.

<sup>2)</sup> DIN EN ISO 4014-12.9 for size 660 x 1020 to 800 x 1230

# CLAMPEX® KTR 700

## Clamping elements

### Rigid shaft coupling to connect two shaft ends



For legend of pictogram refer to flapper on the cover

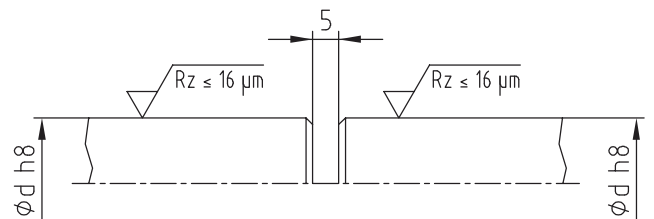
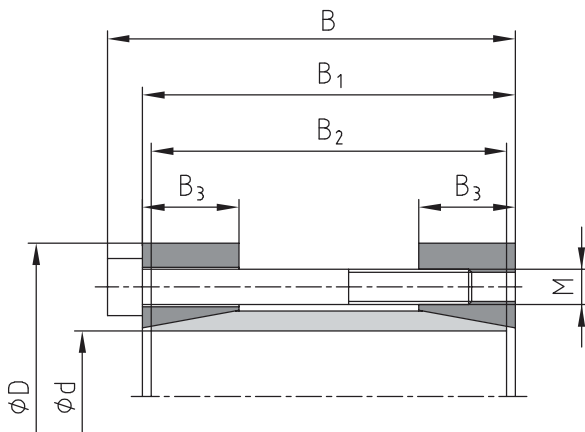

#### Example of application

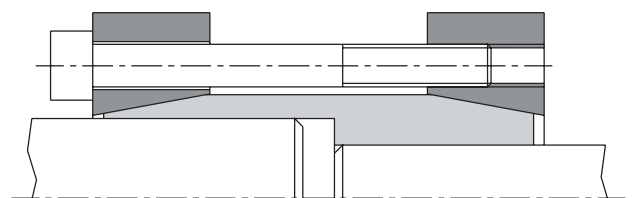
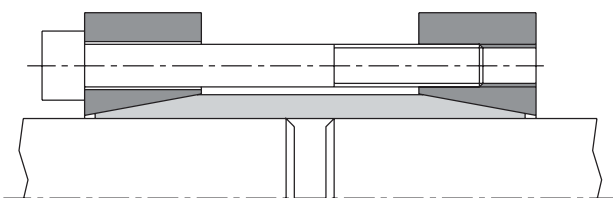

Type on request

<b>Ordering example:</b>	KTR 700	35	x	75
	Series	Size of internal diameter d		Size of external diameter D

CLAMPEX® – KTR 700														
d x D [mm]	Dimensions [mm]				Clamping screws DIN EN ISO 4762 - 12.9 $\mu_{\text{total}}=0.14$				Transmittable torque or axial force			Surface pressure of clamping element/ shaft	Weight [~kg]	Stock pro- gramme
	B	B <sub>1</sub>	B <sub>2</sub>	B <sub>3</sub>	M	Length	z = number	T <sub>A</sub> [Nm]	T [Nm]	F <sub>ax</sub> [kN]	P <sub>W</sub> [N/mm <sup>2</sup> ]			
10 x 35	42	38	36	15	M4	30	6	5.5	62	12	219	0.2		
11 x 35	42	38	36	15	M4	30	6	5.5	66	12	193	0.2		
12 x 35	42	38	36	15	M4	30	6	5.5	72	12	177	0.2		
14 x 35	42	38	36	15	M4	30	6	5	76	11	137	0.2		
15 x 45	56	50	47	15	M6	45	4	17	160	21	252	0.4		
16 x 45	56	50	47	15	M6	45	4	17	170	21	235	0.4		
17 x 45	56	50	47	15	M6	45	4	17	180	21	220	0.4	●	
18 x 50	56	50	47	15	M6	45	4	17	190	21	207	0.5		
19 x 50	56	50	47	15	M6	45	4	17	200	21	196	0.4		
20 x 50	56	50	47	15	M6	45	4	17	220	22	195	0.4	●	
22 x 55	66	60	57	18	M6	55	6	17	360	33	219	0.5		
24 x 55	66	60	57	18	M6	55	6	17	390	33	200	0.6		
25 x 55	66	60	57	18	M6	55	6	17	400	32	189	0.6	●	
28 x 60	66	60	57	18	M6	55	6	17	390	28	147	0.8		
30 x 60	66	60	57	18	M6	55	6	17	420	28	138	0.7	●	
32 x 75	83	75	72	20	M8	70	4	41	610	38	158	0.1		
35 x 75	83	75	72	20	M8	70	4	41	670	38	145	1.3	●	
38 x 75	83	75	72	20	M8	70	4	41	730	38	134	1.2		
40 x 75	83	75	72	20	M8	70	4	41	760	38	126	1.2	●	
42 x 85	93	85	81	22	M8	80	6	41	1170	56	160	1.8		
45 x 85	93	85	81	22	M8	80	6	41	1260	56	150	1.7		
48 x 90	93	85	81	22	M8	80	6	41	1360	57	142	1.9		
50 x 90	93	85	81	22	M8	80	6	41	1400	56	135	1.8	●	
55 x 95	93	85	81	22	M8	80	8	41	2000	73	159	2.0		
60 x 100	93	85	81	22	M8	80	8	41	2260	75	151	2.2	●	
65 x 105	93	85	81	22	M8	80	8	41	2500	77	143	2.6		
70 x 115	110	100	96	35	M10	80	8	83	3300	94	102	4.1		
75 x 120	110	100	96	35	M10	80	8	83	3500	93	94	4.3		
80 x 125	110	100	96	35	M10	80	7	75	3900	98	92	4.5		
90 x 136	110	100	96	35	M10	80	8	75	5100	113	95	5.2		
100 x 158	132	120	116	40	M12	100	8	130	8350	167	111	6.0		

● Sizes of clamping elements available from stock.

# KTR Clamping nuts

Large screw connections for easy and quick assembly

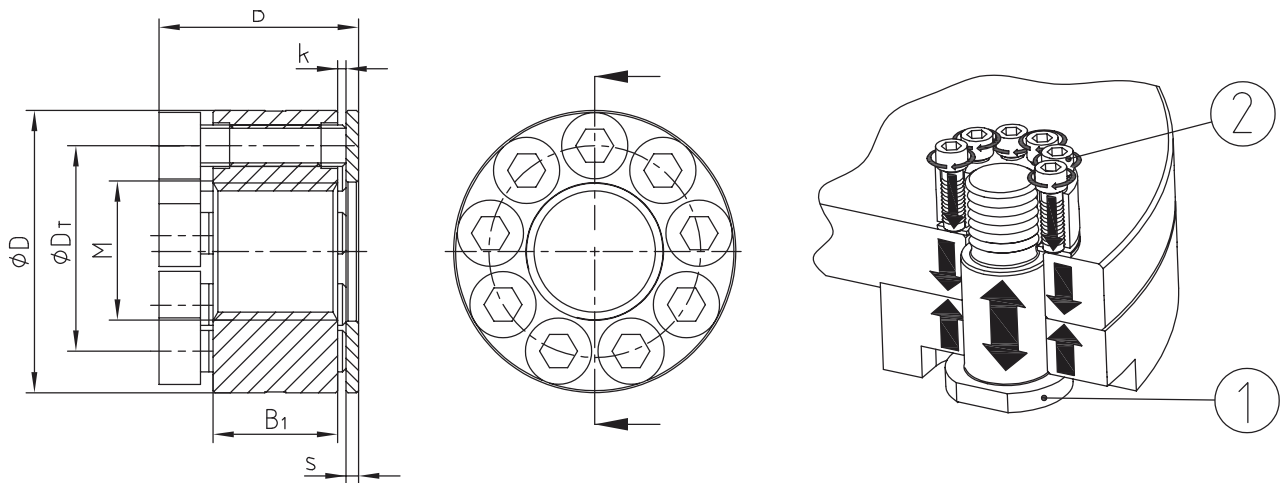
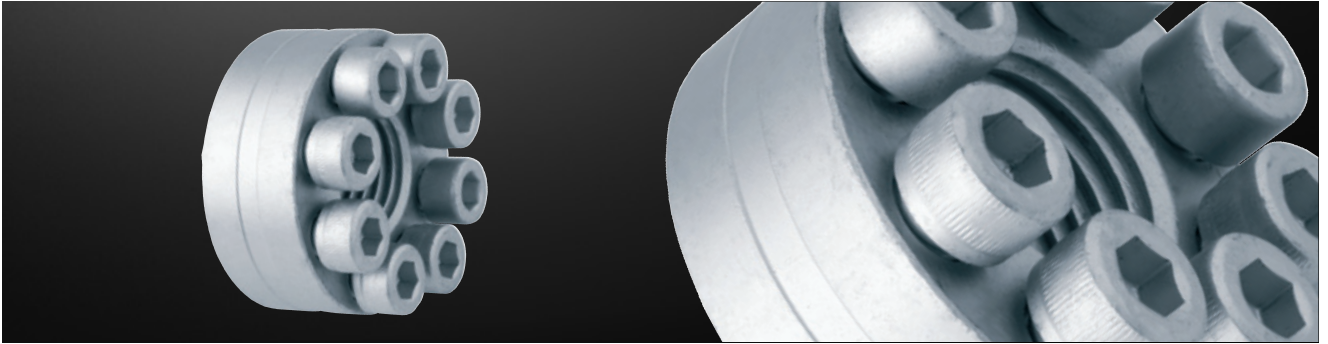

KTR Clamping nuts													
Size	Dimensions [mm]						Pressure screw pos. 2		Property class 8.8, screw pos. 1		Property class 10.9, screw pos. 1		
	D	D <sub>T</sub>	B	B <sub>1</sub>	s	k	DIN EN ISO 4762	z = number	Tightening torque* [Nm]	Preload force [N]	Tightening torque* [Nm]	Preload force [N]	
M24 x 3.0	52	39	36.0	20	3.0	1-2	M8	8	21	174000	30	249000	
M27 x 3.0	57	42	41.0	25	3.0	1-2	M8	9	24	224000	30	280000	
M30 x 3.5	65	48	43.0	25	3.0	1-2	M10	8	41	274000	60	401000	
M33 x 3.5	68	51	48.0	30	3.0	1-2	M10	9	45	338000	60	451000	
M36 x 4.0	80	58	50.0	30	3.0	1-2	M12	8	71	396000	105	586000	
M42 x 4.5	86	64	55.0	35	3.0	1-2	M12	10	78	544000	105	732000	
M48 x 5.0	90	72	60.0	40	3.0	1-2	M12	11	94	721000	105	806000	
M52 x 5.0	100	79	66.5	42	4.5	1-2	M12	13	95	862000	105	952000	
M56 x 5.5	108	83	75.5	45	4.5	1-2	M16	9	210	1001000	250	1192000	
M60 x 5.5	112	86	80.5	48	4.5	1-2	M16	10	215	1139000	250	1325000	
M64 x 6.0	120	92	84.0	52	8.0	1-2	M16	11	225	1311000	250	1457000	
M72 x 6.0	142	107	98.0	58	8.0	1-2	M20	10	400	1696000	490	2077000	
M80 x 6.0	164	122	103.0	64	8.0	1-2	M20	12	420	2137000	490	2493000	

\* per screw pos. 2

Ordering example:	KTR clamping nut	M33 x 3.5
	Description	Size

Used on 100 kNm test bench flanges

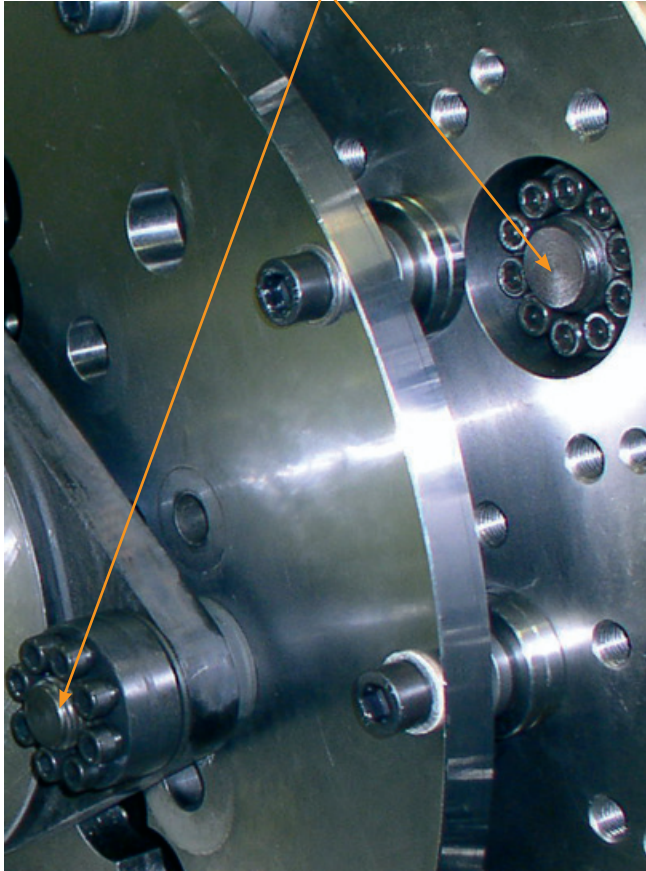

Used on couplings for wind turbines

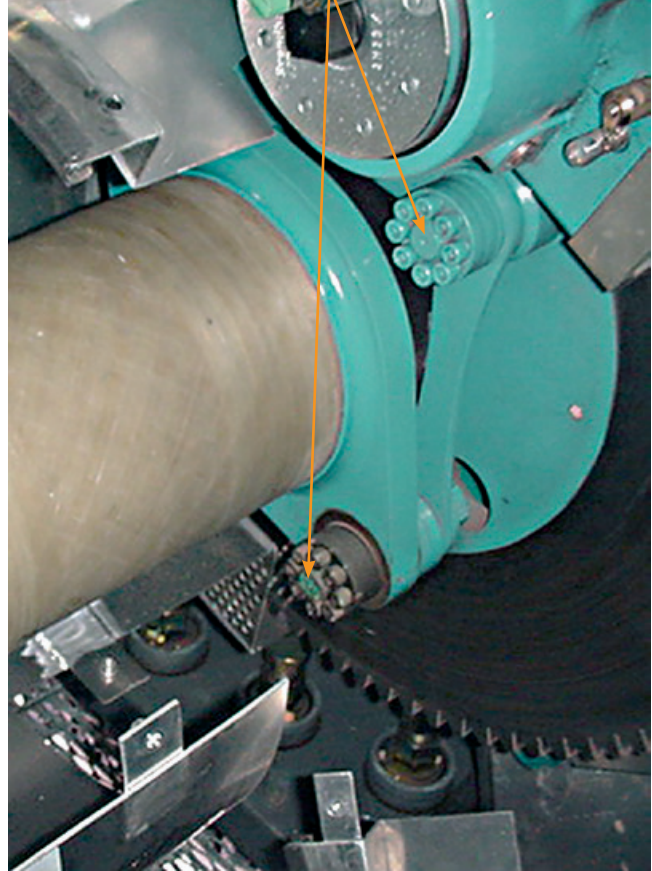

Available as a complete unit including  
dowel screw

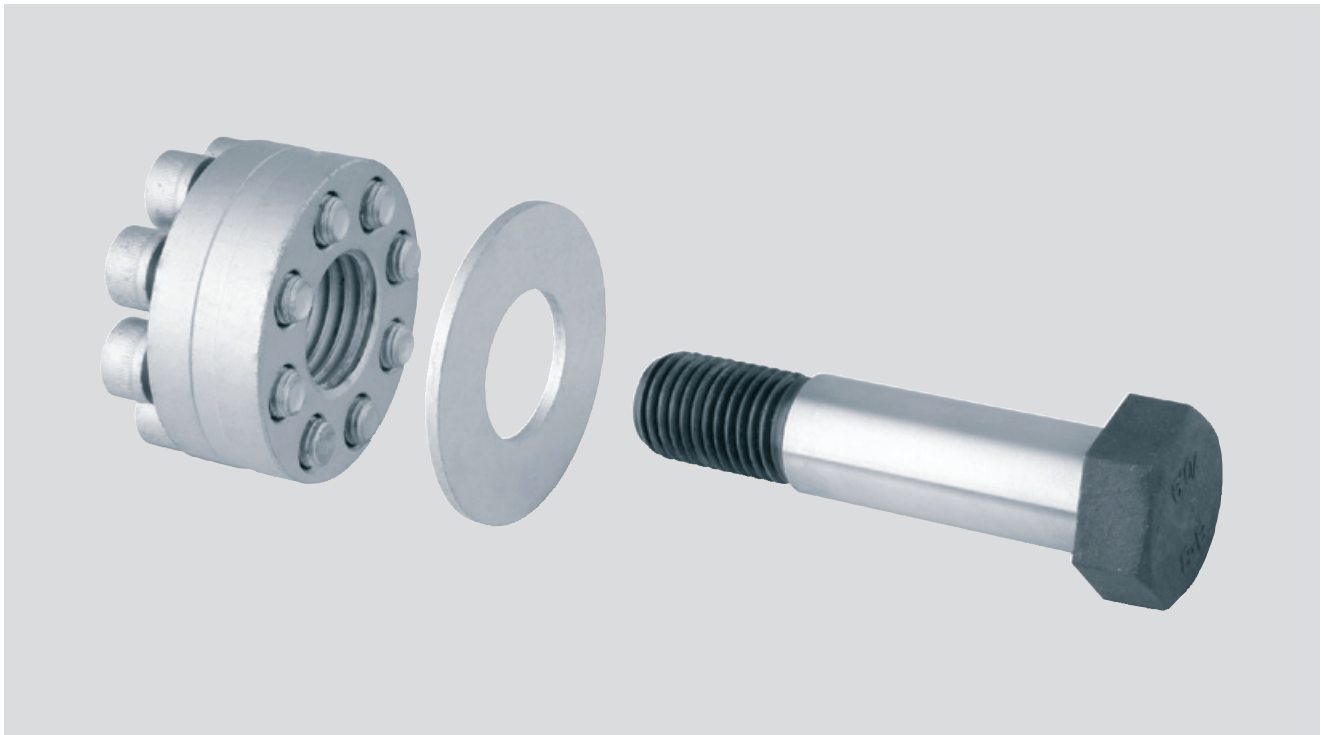

## Precision joints with plain and needle bearing series G and H according to DIN 808

Series G is provided with plain bearings, series H with needle bearings. Series H requires neither lubrication nor maintenance, since its bearings are permanently lubricated.

For low-speed applications (max. 1,000 rpm) precision joints with plain bearings (series G) are recommended. They are able to absorb shock loads, irregular rotation and relatively high torques. With high speeds, relatively low torques, reversing operation or big diffraction angles precision joints with needle bearings (series H) should be preferred. Considering the diffraction angle, they can be used up to a speed of 4,000 rpm.

The maximum diffraction angle is 45° for single joints and 90° for double joints.

## Joints made of stainless steel series X according to DIN 808

Joints series X are fully made of stainless steel 1.4301. The maximum diffraction angle is 45° for single joints and 90° for double joints. The maximum permissible speed for series X is 300 rpm.

## Selection criteria

The permissible torque transmission of a joint over a more or less long period considering constant and shock-free load mainly depends on the number of revolutions per minute and the diffraction angle.

The diagrammes on pages 340 - 341 were created based on such criteria.

The figures in the diagramme shall be considered as reference values referring to single joints only. With the selection of a double joint it must be considered that it is able to transmit a torque falling below that of a single joint of the same size by about 10 %. Every application has special properties, e. g. shock loads, change of direction of rotation, mass moment of inertia, start/stop operation, start-up characteristics etc. that have to be considered with the selection of the joint.

## Instructions for correct assembly

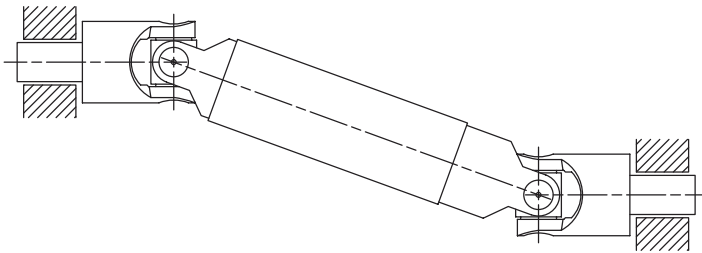

Illustration 1

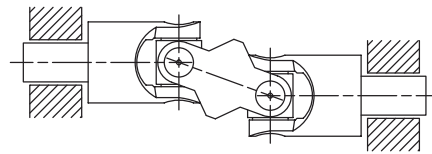

Illustration 2

In order to obtain consistent rotation between driving and driven shaft two single joints or one double joint have to be used. The bearing of the two shafts to be combined should be positioned as close as possible to the joints (see illustration 1 and 2).

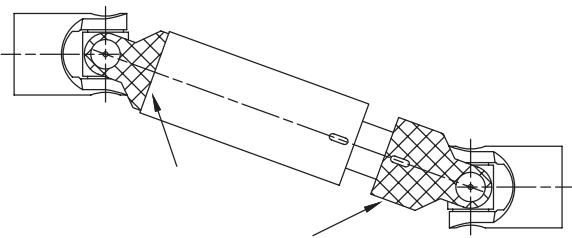

Illustration 3 (correct)

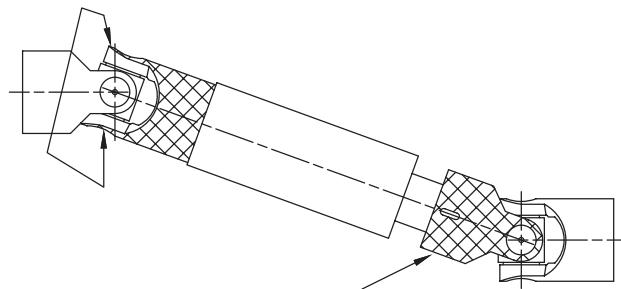

Illustration 4 (not correct)

When using two opposing single joints the identical fork position has to be observed. When using extendable joints it must be made sure that the markings applied are flush (see illustration 3 and 4).

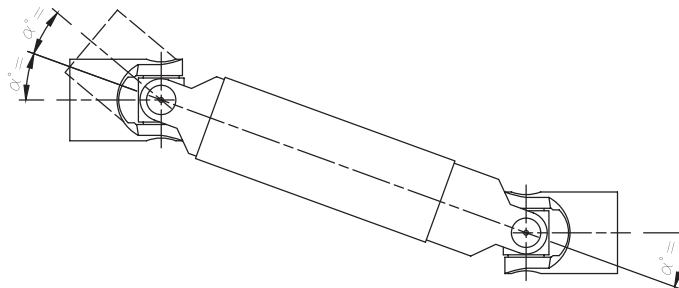
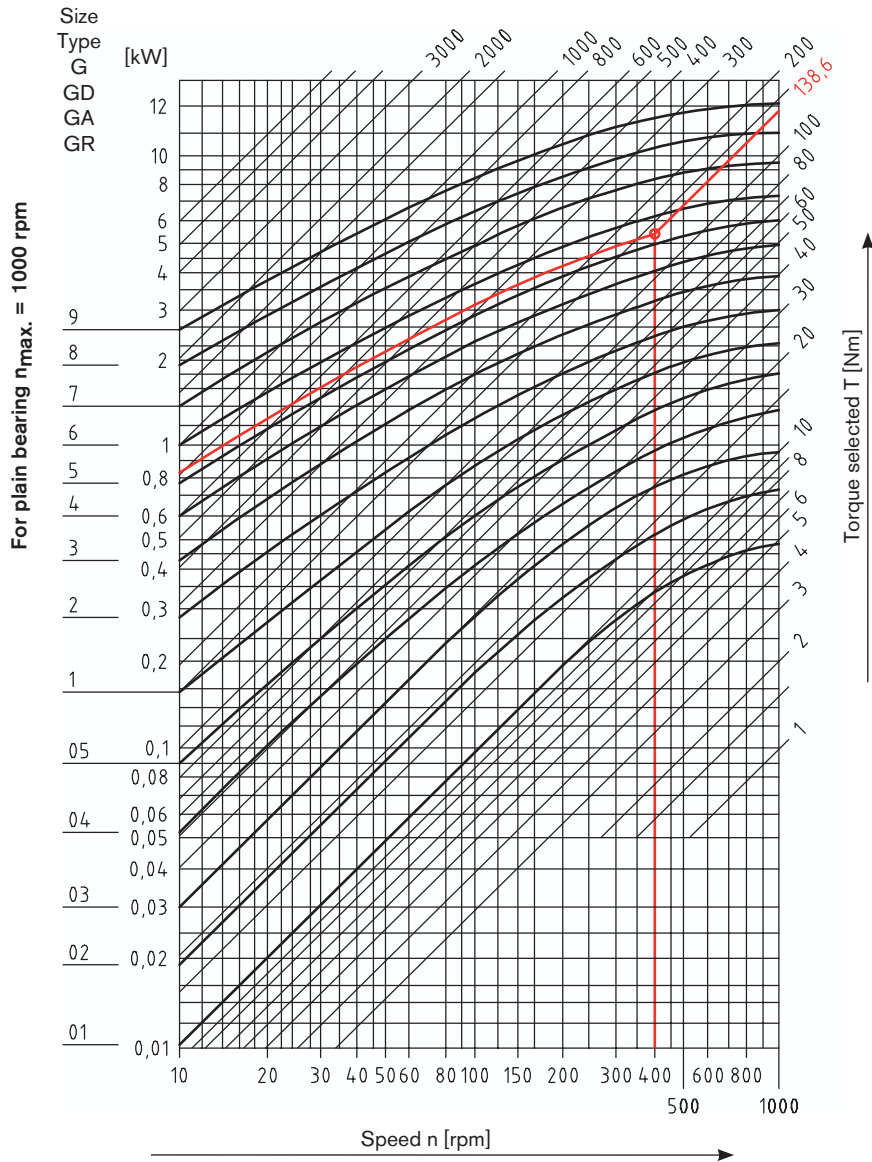

Illustration 5 (correct)

The diffraction angles  $\alpha^\circ$  must be identical (see illustration 5). The shafts may only be arranged in parallel or symmetrically to one another.

## Selection and sizing according to DIN 808 with plain/needle bearing



### Selection of type G, GD, GA, GR (max. 1000 rpm) <sup>1)</sup>

The selection of precision joints with plain bearing is based on the driving torque considering a correction factor which depends on the diffraction angle  $\alpha$  and the operating speed.

For extendable joints the overall length and the speed need to be additionally considered for sizing (please consult with KTR).

$$\text{Driving torque } M_t \text{ [Nm]} = 9550 \cdot \frac{\text{Power [kW]}}{\text{Speed [rpm]}}$$

$$\text{Selection torque } T \text{ [Nm]} = \text{driving torque} \cdot \text{correction factor}$$

Additional review:

$$\text{Diffraction angle } [\alpha] \cdot \text{speed [rpm]} \leq 40,000$$

Diffraction angle $[\alpha]$	5°	10°	15°	20°	25°	30°	35°	40°	45°
Correction factor	0.8	1.00	1.25	1.5	1.8	2.2	2.6	3.3	4.0

Details given:

Driving torque  $M_t$  63 Nm  
 Diffraction angle 30° → Correction factor for diffraction angle 2.2  
 Operating speed 400 rpm

$$\text{Selection torque } T \text{ [Nm]} = 63 \text{ Nm} \cdot 2.2 \rightarrow 138.6 \text{ Nm}$$

Selection based on table: [joint size 6](#)

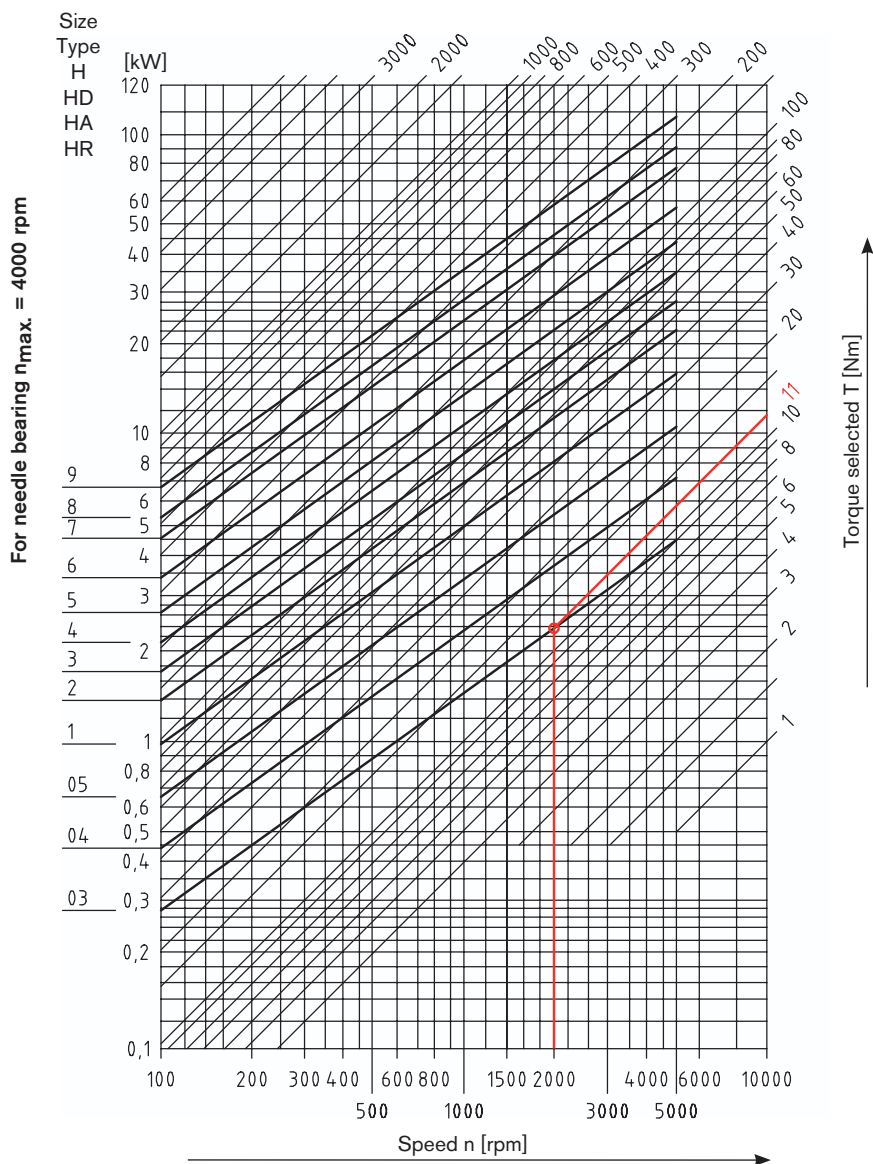

CLAMPEX®

Clamping nuts

## Selection of type H, HD, HA, HR (max. 4000 rpm) <sup>1)</sup>

The selection of precision joints with needle bearing is based on the driving torque considering a correction factor which depends on the diffraction angle  $\alpha$  and the operating speed.

For extendable joints the overall length and the speed need to be additionally considered for sizing (please consult with KTR).

$$\text{Driving torque } M_t \text{ [Nm]} = 9550 \cdot \frac{\text{Power [kW]}}{\text{Speed [rpm]}}$$

$$\text{Selection torque } T \text{ [Nm]} = \text{driving torque} \cdot \text{correction factor}$$

Additional review:

$$\text{Diffraction angle } [\alpha] \cdot \text{speed [rpm]} \leq 40,000$$

Diffraction angle $[\alpha]$	5°	10°	15°	20°	25°	30°	35°	40°	45°
Correction factor	0.8	1.00	1.1	1.25	1.4	2.0	2.5	3.3	4.0

Details given:

Driving torque  $M_t$

8.8 Nm

Diffraction angle

20°

→ Correction factor for diffraction angle 1.25

Operating speed

2000 rpm

$$\text{Selection torque } T \text{ [Nm]} = 8.8 \text{ Nm} \cdot 1.25 \rightarrow 11 \text{ Nm}$$

Selection based on table: joint size 03

KTR Precision joints

Clamping sets

# KTR Precision joints type G and GD

According to DIN 808 with plain bearing



For legend of pictogram refer to flapper on the cover



Precision single joint G

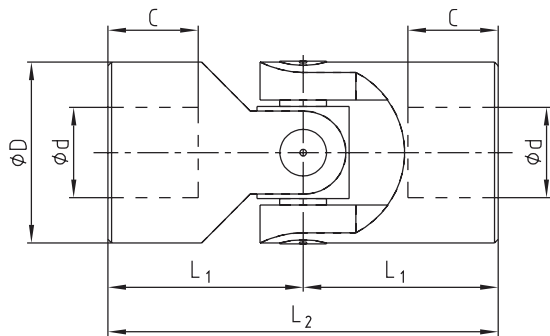

Precision double joint GD

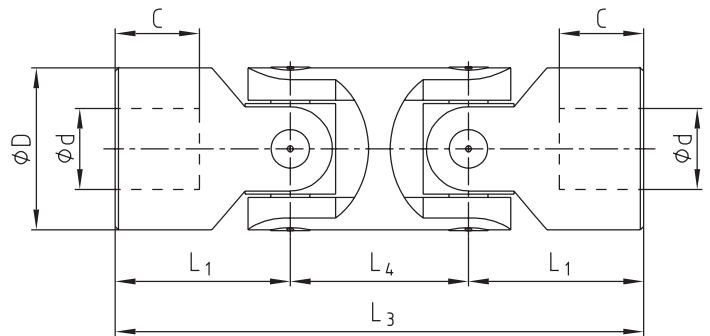

Bore options:

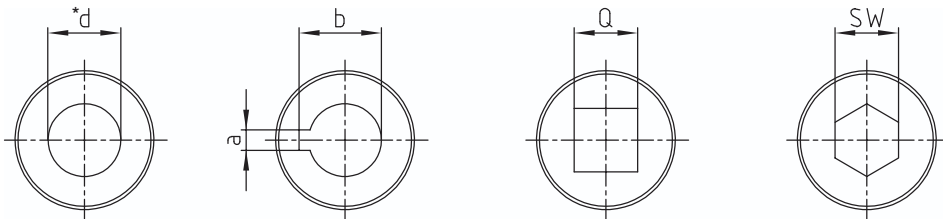

\* Standard type of bore, unless differently inquired/ordered

Type G and GD																
Types and size														Weight [kg]		
Size G	DIN designation G	Size GD	DIN designation GD	d (H7)	D	L <sub>2</sub>	L <sub>1</sub>	C	L <sub>4</sub>	L <sub>3</sub>	a (JS9)	b	Q (H10)	SW (H10)	G	GD
01 G	E6 x 16-G	01 GD	D6 x 16-G	6	16	34	17	8	22	56	2	7.0	6	6	0.05	0.08
02 G	E8 x 16-G	02 GD	D8 x 16-G	8	16	40	20	11	22	62	2	9.0	8	8	0.05	0.08
03 G	E10 x 22-G	03 GD	D10 x 22-G	10	22	48	24	12	26	74	3	11.4	10	10	0.10	0.15
04 G	E12 x 25-G	04 GD	D12 x 25-G	12	25	56	28	13	30	86	4	13.8	12	12	0.16	0.25
05 G	E14 x 28-G	05 GD	D14 x 28-G	14	28	60	30	14	36	96	5	16.3	14	14	0.20	0.40
1 G	E16 x 32-G	1 GD	D16 x 32-G	16	32	68	34	16	37	105	5	18.3	16	16	0.30	0.45
2 G	E18 x 36-G	2 GD	D18 x 36-G	18	36	74	37	17	40	114	6	20.8	18	18	0.45	0.70
3 G	E20 x 42-G	3 GD	D20 x 42-G	20	42	82	41	18	47	129	6	22.8	20	20	0.60	1.00
4 G	E22 x 45-G	4 GD	D22 x 45-G	22	45	95	47.5	22	50	145	6	24.8	22	22	0.95	1.55
5 G	E25 x 50-G	5 GD	D25 x 50-G	25	50	108	54	26	55	163	8	28.3	25	25	1.20	2.00
6 G	E30 x 58-G	6 GD	D30 x 58-G	30	58	122	61	29	68	190	8	33.3	30	30	1.85	2.90
6 G1	E32 x 58-G	6 GD1	D32 x 58-G	32	58	130	65	33	68	198	10	35.3	30	30	2.00	3.00
7 G	E35 x 70-G	7 GD	D35 x 70-G	35	70	140	70	33	72	212	10	38.3	-	-	3.15	4.75
8 G	E40 x 80-G	8 GD	D40 x 80-G	40	80	160	80	38	85	245	12	43.3	-	-	4.60	7.20
9 G	E50 x 95-G	9 GD	D50 x 95-G	50	95	190	95	46	100	290	14	53.8	-	-	7.60	12.0

Ordering example:	04 G	Ø12	Ø12 keyway to DIN
	Size and type of joint	Finish bore (H7)	Finish bore (H7), feather keyway acc. to DIN 6885 sheet 1 (JS9)

# KTR Precision joints type H and HD

According to DIN 808 with needle bearing



For legend of pictogram refer to flapper on the cover



Precision single joint type H

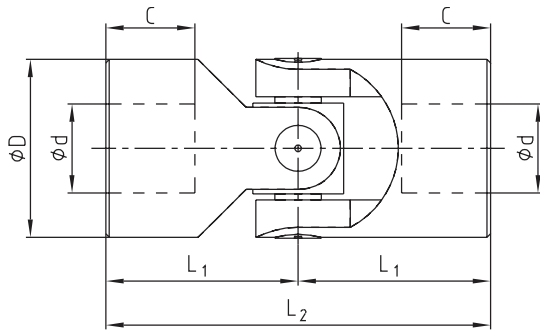

Precision double joint type HD

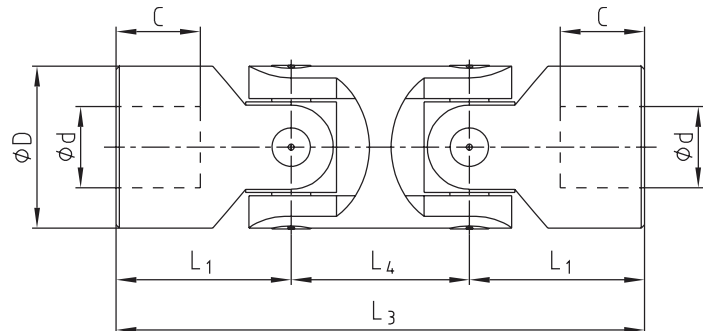

## Bore options:

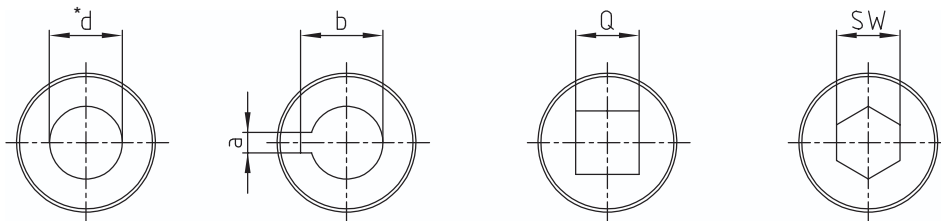

\* Standard type of bore, unless differently inquired/ordered

Type H and HD																
Types and size				Dimensions [mm]										Weight [kg]		
Size H	DIN designation H	Size HD	DIN designation HD	d (H7)	D	L <sub>2</sub>	L <sub>1</sub>	C	L <sub>4</sub>	L <sub>3</sub>	a (JS9)	b	Q (H10)	SW (H10)	H	HD
03 H	E10 x 22-W	03 HD	D10 x 22-W	10	22	48	24	12	26	74	3	11.4	10	10	0.10	0.15
04 H	E12 x 25-W	04 HD	D12 x 25-W	12	25	56	28	13	30	86	4	13.8	12	12	0.16	0.25
05 H	E14 x 28-W	05 HD	D14 x 28-W	14	28	60	30	14	36	96	5	16.3	14	14	0.20	0.40
1 H	E16 x 32-W	1 HD	D16 x 32-W	16	32	68	34	16	37	105	5	18.3	16	16	0.30	0.45
2 H	E18 x 36-W	2 HD	D18 x 36-W	18	36	74	37	17	40	114	6	20.8	18	18	0.45	0.70
3 H	E20 x 42-W	3 HD	D20 x 42-W	20	42	82	41	18	47	129	6	22.8	20	20	0.60	1.00
4 H	E22 x 45-W	4 HD	D22 x 45-W	22	45	95	47.5	22	50	145	6	24.8	22	22	0.95	1.55
5 H	E25 x 50-W	5 HD	D25 x 50-W	25	50	108	54	26	55	163	8	28.3	25	25	1.20	2.00
6 H	E30 x 58-W	6 HD	D30 x 58-W	30	58	122	61	29	68	190	8	33.3	30	30	1.85	2.90
6 H1	E32 x 58-W	6 HD1	D32 x 58-W	32	58	130	65	33	68	198	10	35.3	30	30	2.00	3.00
7 H	E35 x 70-W	7 HD	D35 x 70-W	35	70	140	70	33	72	212	10	38.3	-	-	3.15	4.75
8 H	E40 x 80-W	8 HD	D40 x 80-W	40	80	160	80	38	85	245	12	43.3	-	-	4.60	7.20
9 H	E50 x 95-W	9 HD	D50 x 95-W	50	95	190	95	46	100	290	14	53.8	-	-	7.60	12.0

Ordering example:	1 H	Ø16	Ø16 keyway to DIN
	Size and type of joint	Finish bore (H7)	Finish bore (H7), feather keyway acc. to DIN 6885 sheet 1 (JS9)

# KTR Precision joints type GA and HA

According to DIN 808 with plain and needle bearing (extendable)

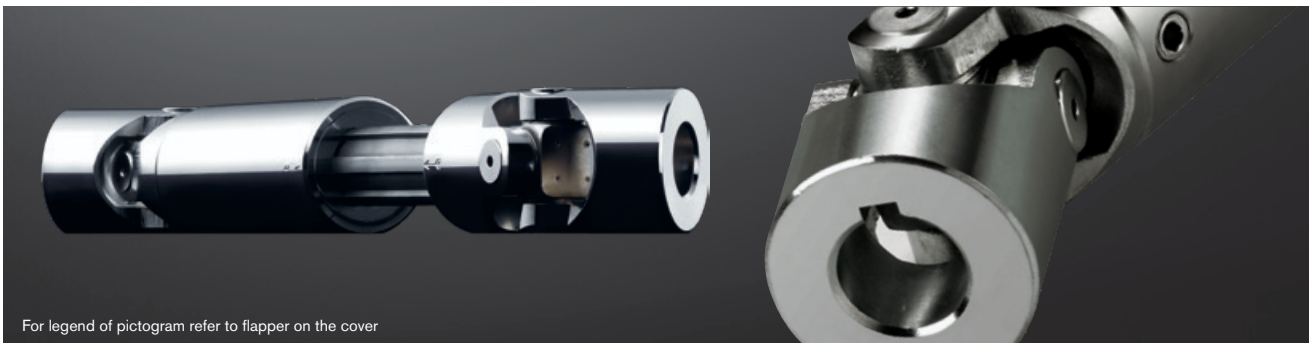

For legend of pictogram refer to flapper on the cover

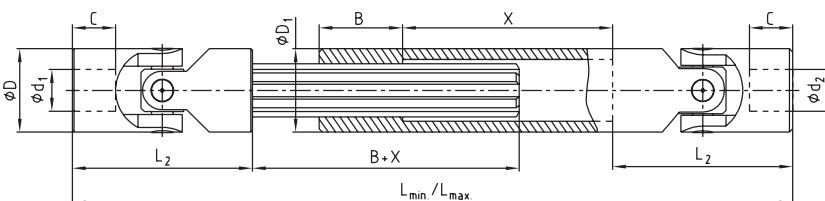
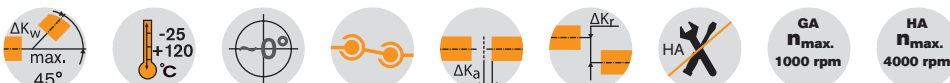

Preferred lengths									
Size	Dimensions [mm]								
	L <sub>min.</sub> / L <sub>max.</sub>								
03	140	160	180	230					
	170	200	240	330					
04	160	180	200	220	250	280	300		
	190	225	270	300	355	420	450		
05	170	180	200	220	250	280	300	350	400
	200	220	260	300	350	420	450	550	650
1	190	210	240	250	275	300	380	400	
	220	250	320	350	390	430	590	630	
2	230	250	270	290	300	400	500		
	280	320	370	400	415	620	820		
3	250	270	290	320	380	420	500		
	300	340	380	440	560	640	800		
4	250	270	290	330	350	470			
	280	320	350	430	470	710			
5	295	310	350	380	420	460	500		
	345	375	450	500	590	660	745		
6	330	350	370	400	450	500	540		
	380	420	455	510	620	720	795		

Bore options:

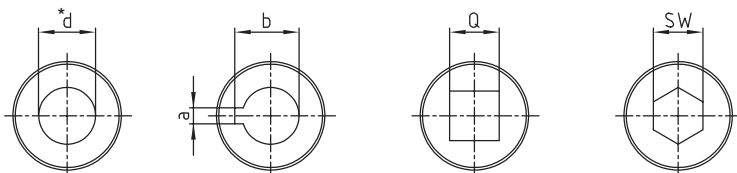

\* Standard type of bore, unless differently inquired/ordered

Type GA with plain bearing n <sub>max.</sub> = 1000 rpm and type HA with needle bearing n <sub>max.</sub> = 4000 rpm													
Size		Dimensions [mm]										Splines shaft	D <sub>1</sub>
GA	HA	d <sub>1</sub> , d <sub>2</sub> (H7)	D	L <sub>2</sub>	C	L <sub>min.</sub> / L <sub>max.</sub> / X	B	a (JS9)	b	Q (H10)	SW (H10)		
01 GA	-	6	16	34	8	← →	25	2	7.0	6	6	SW8	16
02 GA	-	8	16	40	11	← →	25	2	9.0	8	8	SW8	16
03 GA	03 HA	10	22	48	12	← →	30	3	11.4	10	10	11 x 14 Z6	22
04 GA	04 HA	12	25	56	13	← →	40	4	13.8	12	12	13 x 16 Z6	26
05 GA	05 HA	14	28	60	14	← →	40	5	16.3	14	14	13 x 16 Z6	29
1 GA	1 HA	16	32	68	16	← →	40	5	18.3	16	16	16 x 20 Z6	32
2 GA	2 HA	18	36	74	17	← →	40	6	20.8	18	18	18 x 22 Z6	37
3 GA	3 HA	20	42	82	18	← →	45	6	22.8	20	20	21 x 25 Z6	42
4 GA	4 HA	22	45	95	22	← →	45	6	24.8	22	22	23 x 28 Z6	47
5 GA	5 HA	25	50	108	26	← →	45	8	28.3	25	25	26 x 32 Z6	52
6 GA	6 HA	30	58	122	29	← →	50	8	33.3	30	30	32 x 38 Z8	58
7 GA	7 HA	35	70	140	33	← →	70	10	38.3	-	-	36 x 42 Z8	70
8 GA	8 HA	40	80	160	38	← →	80	12	43.3	-	-	42 x 48 Z8	80
9 GA	9 HA	50	95	190	46	← →	90	14	53.8	-	-	46 x 54 Z8	95

Calculation of mounting lengths L and X (stroke)

$$\text{Stroke } X \geq \frac{L_{\max.} - 2 \cdot L_2 - B}{2}$$

$$L_{\min.} \geq \frac{L_{\max.} + 2 \cdot L_2 + B}{2}$$

$$\text{Minimum size } L_{\min.} = L_2 + B + X + L_2$$

Ordering example:	3 GA	d <sub>1</sub> = Ø20	d <sub>2</sub> = Ø20 keyway to DIN	550/650
	Size and type of joint	Finish bore (H7)	Finish bore (H7), feather keyway acc. to DIN 6885 sheet 1 (JS9)	Mounting length L <sub>min.</sub> /L <sub>max.</sub>

# KTR Precision joints type X and XD

According to DIN 808 with plain bearing made of stainless steel 1.4301



For legend of pictogram refer to flapper on the cover



Precision single joint X

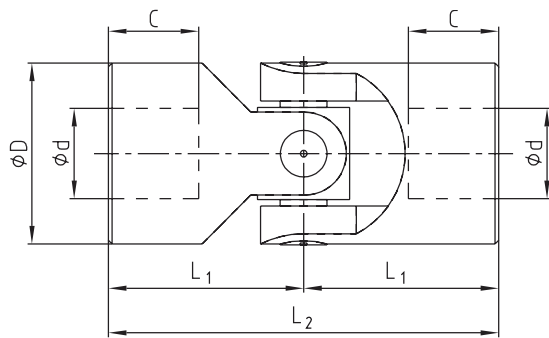

Precision double joint XD

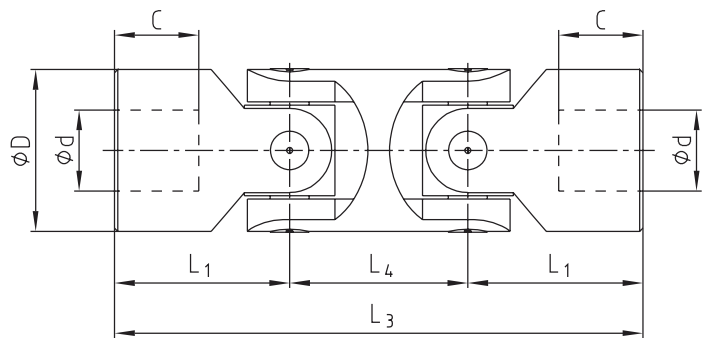

## Bore options:

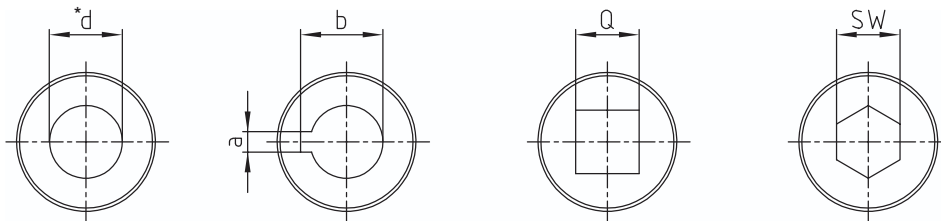

\* Standard type of bore, unless differently inquired/ordered

Type X and XD																
Types and size				Dimensions [mm]											Weight [kg]	
Size X	DIN designation X	Size XD	DIN designation XD	d (H7)	D	L <sub>2</sub>	L <sub>1</sub>	C	L <sub>4</sub>	L <sub>3</sub>	a (JS9)	b	Q (H10)	SW (H10)	X	XD
01 X	E6 x 16-G	01 XD	D6 x 16-G	6	16	34	17	8	22	56	2	7.0	6	6	0.05	0.08
02 X	E8 x 16-G	02 XD	D8 x 16-G	8	16	40	20	11	22	62	2	9.0	8	8	0.05	0.08
03 X	E10 x 22-G	03 XD	D10 x 22-G	10	22	48	24	12	26	74	3	11.4	10	10	0.10	0.15
04 X	E12 x 25-G	04 XD	D12 x 25-G	12	25	56	28	13	30	86	4	13.8	12	12	0.16	0.25
05 X	E14 x 28-G	05 XD	D14 x 28-G	14	28	60	30	14	36	96	5	16.3	14	14	0.20	0.40
1 X	E16 x 32-G	1 XD	D16 x 32-G	16	32	68	34	16	37	105	5	18.3	16	16	0.30	0.45
3 X	E20 x 42-G	3 XD	D20 x 42-G	20	42	82	41	18	47	129	6	22.8	20	20	0.60	1.00
5 X	E25 x 50-G	5 XD	D25 x 50-G	25	50	108	54	26	55	163	8	28.3	25	25	1.20	2.00
6 X	E30 x 58-G	6 XD	D30 x 58-G	30	58	122	61	29	68	190	8	33.3	30	30	1.85	2.90

Ordering example:	04 X	Ø12	Ø12 keyway to DIN
	Size and type of joint	Finish bore (H7)	Finish bore (H7), feather keyway acc. to DIN 6885 sheet 1 (JS9)

# KTR Precision joints type GR and HR

## Plain and needle bearing with quick locking

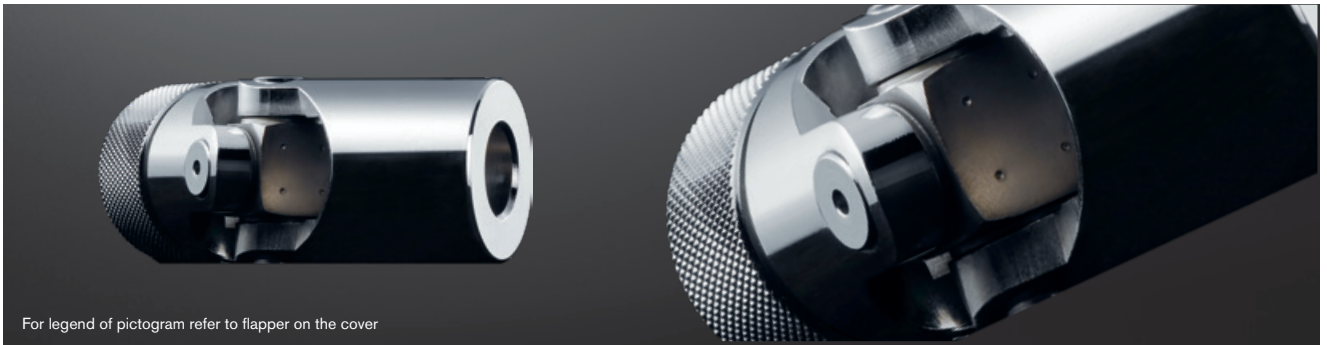

For legend of pictogram refer to flapper on the cover

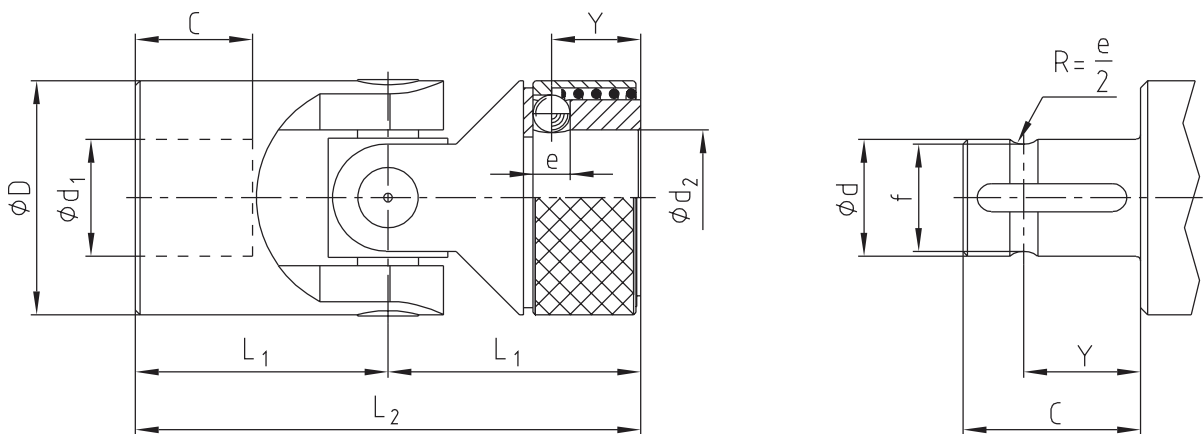

### Bore options:

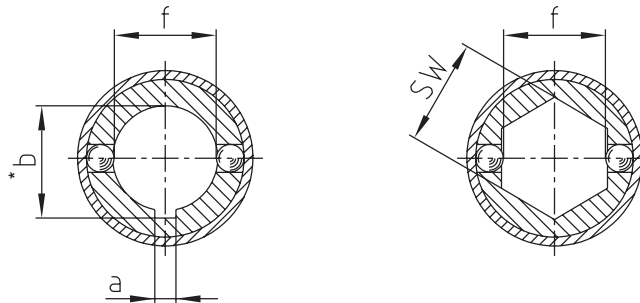

\* Standard type of bore of quick locking, unless differently inquired/ordered

### Type GR with plain bearing $n_{max.} = 1000$ rpm and type HR with needle bearing $n_{max.} = 4000$ rpm

Size		Dimensions [mm]											Weight [kg]
GR	HR	$d_1, d_2$ (H7)	D	$L_2$	$L_1$	C	Y	e	f	a (JS9)	b	SW (H10)	
02 GR	-	8	16	52	26	14	9.5	3.5	6.3	2	9.0	8	0.05
03 GR	03 HR	10	22	62	31	17	11.5	4.0	8.7	3	11.0	10	0.12
04 GR	04 HR	12	25	74	37	21	13.5	4.0	11.0	4	13.3	12	0.19
05 GR	05 HR	14	25	74	37	21	13.5	4.0	13.0	5	15.3	14	0.17
1 GR	1 HR	16	32	86	43	24	14.0	6.35	14.8	5	18.3	16	0.34
2 GR	2 HR	18	36	96	48	28	19.0	8.0	16.0	6	20.8	18	0.48
3 GR	3 HR	20	42	108	54	31	19.0	8.0	18.0	6	22.8	20	0.76
4 GR	4 HR	22	45	120	60	34	20.5	10.0	20.0	6	24.8	22	0.97
5 GR	5 HR	25	50	132	66	38	20.5	10.0	23.0	8	28.3	25	1.3
6 GR	6 HR	30	58	166	83	49	25.0	10.0	28.0	8	33.3	30	2.13

Ordering example:

03 HR	$d_1 = \text{Ø}10$	$d_2 = \text{Ø}10$ keyway to DIN
Size and type of joint	Finish bore (H7)	Finish bore (H7), feather keyway acc. to DIN 6885 sheet 1 (JS9)

## Protection bushings

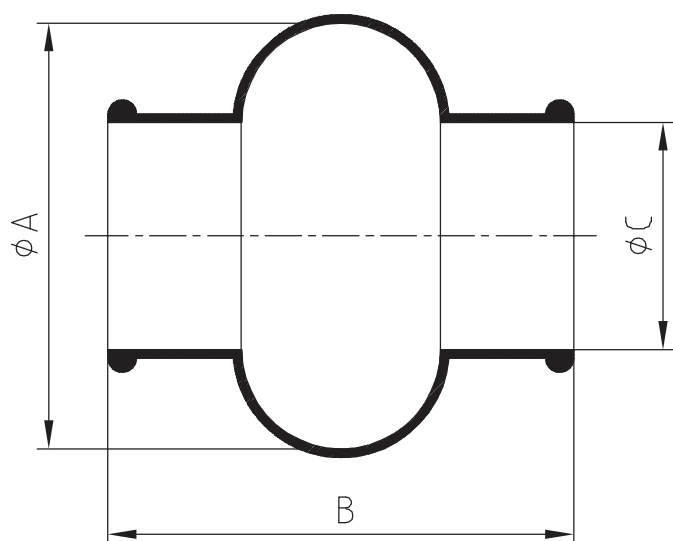

CLAMPEX®

Clamping nuts

Protection bushings				
Size	Precision joints	A	B	C
M 01	01 G, 01 X	28	34	15
M 02	02 G, 02 X, 02 GR	32	40	16.5
M 03	03 G, 03 H, 03 GA, 03 HA, 03 X, 03 GR, 03 HR	40	45	20.5
M 04	04 G, 04 H, 04 GA, 04 HA, 04 X, 04 GR, 04 HR	48	50	24.5
M 05	05 G, 05 H, 05 GA, 05 HA, 05 GR, 05 HR	52	56	27.5
M 1	1 G, 1 H, 1 GA, 1 HA, 1 X, 1 GR, 1 HR	56	65	30.5
M 2	2 G, 2 H, 2 GA, 2 HA, 2 GR, 2 HR	66	72	35.5
M 3	3 G, 3 H, 3 GA, 3 HA, 3 X, 3 GR, 3 HR	75	82	40.0
M 4	4 G, 4 H, 4 GA, 4 HA, 4 GR, 4 HR	84	95	45.0
M 5	5 G, 5 H, 5 GA, 5 HA, 5 X, 5 GR, 5 HR	92	108	50.0
M 6	6 G, 6 G1, 6 H, 6 H1, 6 GA, 6 HA, 6 X, 6GR, 6 HR	100	122	56.0

KTR Precision joints

Clamping sets



# Torque measuring technology

## Torque measuring shafts

Types and operating description 342

---

### DATAFLEX®

Type 16/10, 16/30, 16/50 344

Type 32/100, 32/300, 32/500 346

Type 42/1000 348

Type 70/3000, 70/5000 350

Type 110/10000, 110/20000 352

Connection accessories 353

---

## Torque measuring coupling hub

### MONITEX® BT

Type 28/200 354

Type 42/800 356

DAC – analog output 356

DATAFLEX® 16



DATAFLEX® 32



DATAFLEX® 42



DATAFLEX® 70



DATAFLEX® 110

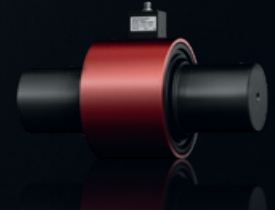

MONITEX® BT 28/200



MONITEX® BT 42/800



# TORQUE MEASURING TECHNOLOGY TYPES AND OPERATING DESCRIPTION

## Properties of torque measuring shafts

DATAFLEX® 16, 32, 42, 70, 110 – Dual-range measuring shaft providing for high precision



The KTR torque sensors type DATAFLEX® 16 to DATAFLEX® 110 cover a torque range from 10 Nm to 20,000 Nm.

The torque is measured using the approved technology of DMS wire strain gauges while processing contactlessly with a resolution of 24 bits. Thus, the inaccuracy of torque measuring is reduced to less than 0.1 % of the measuring range. By integrating a high-resolution speed sensor the new series combines four measurements in one: Measuring the torque, speed, rotation angle and rotation direction is part of the standard equipment. A new feature is the option to switch the measuring range of each measuring shaft to one fifth of the rated torque. This option allows to measure smaller torques precisely without changing the design.

MONITEX® BT 28/200, 42/800 – Torque measuring coupling hub



MONITEX® BT is a ROTEX® GS coupling hub with an integrated measuring system for measuring torque and speed. Subject to its short design the system can replace a standard ROTEX® hub in many cases while easy to assemble.

The inductive energy supply is implemented by an inductive head that is fitted radially to the coupling with a maximum distance of 10 mm. As soon as the system is switched on, the measured torque and speed data are sent by the MONITEX® BT via bluetooth and can be received by a smartphone, a tablet or a PC via the free MONITEX® BT app. Besides a digital-to-analog converter is available displaying the torque and speed data as voltage ( $\pm 10$  V) and simultaneously as current (4-20 mA) (e. g. for existing controls).

## Customised solutions and special designs



Besides KTR precision measuring shafts KTR manufactures and calibrates customised measuring shafts for measuring ranges up to 500 kNm. In this context key parameters such as measuring range, size, length and coupling type can be adjusted to the specifications. The torque is measured contactlessly so that bearings are not required.

Apart from customised torque sensors KTR provides special solutions with couplings equipped with torque measuring technology so that the design does not have to be modified.

# TORQUE MEASURING TECHNOLOGY TYPES AND OPERATING DESCRIPTION

## Product finder of torque measuring shafts

Product	DATAFLEX® 16	DATAFLEX® 32	DATAFLEX® 42	DATAFLEX® 70	DATAFLEX® 110	MONITEX® BT 28/200	MONITEX® BT 42/800	customised
maintenance-free	●	●	●	●	●	●	●	●
For rotating applications	●	●	●	●	●	●	●	●
Dual-range measuring shaft	●	●	●	●	●	–	–	–
Measuring range 1 $T_{KN}$ [Nm]	10, 30, 50	100, 300, 500	1000	3000, 5000	10000, 20000	200	800	up to 500000
Measuring range 2 $T_{KN2}$ [Nm]	2, 6, 10	20, 60, 100	200	600, 1000	2000, 4000	–	–	–
Inaccuracy (% of $T_{KN}/T_{KN2}$ )	< 0.1/0.2	< 0.1/0.2	< 0.1/0.2	< 0.1/0.2	< 0.1/0.2	< 0.25	< 0.25	< 0.2
Torque output	-10 ... 10 V	-10 ... 10 V	-10 ... 10 V	-10 ... 10 V	-10 ... 10 V	Bluetooth, App, PC, -10 ... 10 V, 4 ... 20 mA <sup>1)</sup>		-10 ... 10 V, 4 ... 20 mA
Speed output								
Square-wave signal [pulses/rev.]	2 x 360	2 x 720	2 x 720	2 x 450	2 x 720	–	–	–
DC - direct voltage signal [0 ... 10V]	●	●	●	●	●	● <sup>1)</sup>	● <sup>1)</sup>	–
Direction signal	●	●	●	●	●	–	–	–
Maximum speed [rpm]	10,000	7,500	6,500	4,000	3,000	3500	3500	miscellaneous
Recommended coupling	RADEX®-NC 21, 26	RADEX®-NC 36 RADEX®-N 60	RADEX®-N 80	RADEX®-N 90, 115	as specified	ROTEX® GS 28	ROTEX® GS 42	as specified
Connection housing DF2	●	●	●	●	●	–	–	–

<sup>1)</sup> With DAC (digital-to-analog converter)

### DATAFLEX® Connection housing DF2

(see page 361)



The connection housing DF2 can easily be combined with all DATAFLEX® torque measuring shafts disposing of a retainer for top hat rail assembly as well as terminal screws for an easy connection of external devices.

The following features save the purchase of expensive measuring amplifiers and converters:

- The torque output can be filtered over 5 steps so that short torque peaks in the display can be reduced.
- The pulsed outputs of the speed signals can be configured both for 5 V (TTL) and 24 V (HTL) controls. This makes the outputs compatible with data logging boards and SPS controls.
- In parallel with the pulse signal, an integrated frequency voltage converter supplies a DC voltage from 0 – 10 V proportionally to the speed, the scaling of which can be individually adapted. This makes an expensive counter superfluous so that the signal can either be processed as a voltage or displayed.
- A direction signal indicates the rotational direction of the drive (with DATAFLEX® 16, 32, 42, 70 and 110).

### MONITEX® BT DAC - Analog outputs

(see page 364)



The DAC connects to the torque measuring MONITEX® BT coupling hub displaying the data for torque and speed as analog voltage and current. The DAC allows for integrating the MONITEX® BT torque and speed data in the control systems.

# DATAFLEX® 16/10, 16/30, 16/50 DUAL-RANGE TORQUE SENSOR

for torques up to 50 Nm



For legend of pictogram refer to flapper on the cover



### General properties

DATAFLEX® type	Measuring range 1 T <sub>KN</sub> [Nm]	Measuring range 2 T <sub>KN2</sub> [Nm]	Supply voltage [V]	Current consumption [mA]	Operating temperature range [°C]
16/10	-10 ... +10	-2 ... +2	24 ±4	<100	0 ... 55
16/30	-30 ... +30	-6 ... +6			
16/50	-50 ... +50	-10 ... +10			

### Technical data of torque signal

### Technical data of speed signal

DATAFLEX® type	Inaccuracy [%] <sup>1), 2), 3)</sup>	Output voltage [V]	Bandwidth [kHz]	Influence of temperature <sup>1)</sup> [%/10 °C]	Resolution [pulses/rev.]	Number of channels	Square-wave signal <sup>4)</sup> [V <sub>ss</sub> ]	Direct voltage signal <sup>4)</sup> [V]	Direction signal <sup>4)</sup> [V]
16/10									
16/30	<0.1/0.2	-10 ... 10	2	0.05	360	2, 90° offset	5/24	0 ... 10, scalable	5/24
16/50									

### Mechanical data of torque measuring shaft

DATAFLEX® type	Static load limit <sup>1)</sup> T <sub>K max</sub> [%]	Breaking load T <sub>K break</sub> <sup>1)</sup> [%]	Max. bending torque [Nm]	Max. radial force [N]	Max. axial force [kN]	Weight [kg]	Torsion spring stiffness C <sub>T</sub> [Nm/rad]	Torsion angle with T <sub>KN</sub> [°]	Mass moment of inertia [kgmm <sup>2</sup> ]	Max. speed <sup>5)</sup> [rpm]
16/10			1.07	12	1.1		910	0.63		
16/30	150	300	3.2	37	2.3	0.7	2840	0.61	22.6	10000
16/50			5.3	61	3.1		4100	0.7		

### Mechanical data of combination of DATAFLEX® 16 and RADEX®-NC

DATAFLEX® type	Coupling			Mechanical data of combination			
	RADEX®-NC size	Clamping screw M		Mass moment of inertia [kgmm <sup>2</sup> ]	Torsion spring stiffness C <sub>T</sub> [Nm/rad]	Weight [kg]	Max. speed <sup>5)</sup> [rpm]
		M	T <sub>A</sub> [Nm]				
16/10	21	M6	10	323	2500	1.30	10000
16/30							
16/50							

<sup>1)</sup> Referring to T<sub>KN</sub>

<sup>2)</sup> Referring to T<sub>KN2</sub>

<sup>3)</sup> Error in linearity incl. hysteresis

<sup>4)</sup> See page 361: with connection housing DF2

<sup>5)</sup> Using RADEX®-NC 3.5 hubs, with other couplings 7500 rpm.

**Ordering example:**

DATAFLEX® 16/30	DF2	2 m, 5 m and 10 m	RADEX®-NC 21 EK Ø16/20-Ø16/30
Type of measuring shaft with measuring range	Connection housing (is required)	Connection cable	If any accessories are requested: coupling type, finish bores D/DW

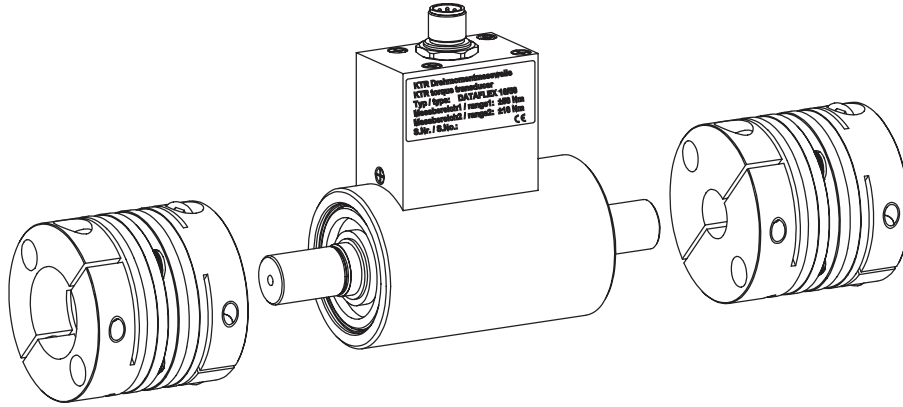

DATAFLEX® 16

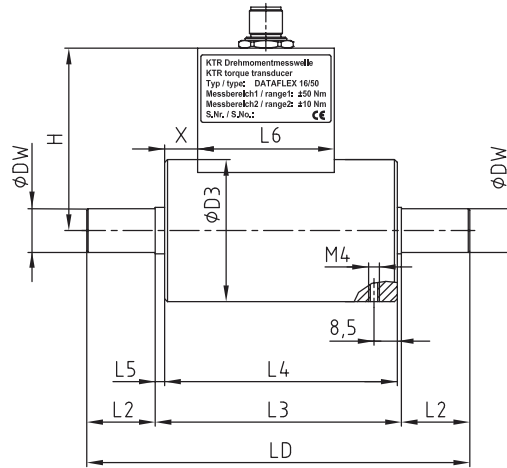

Combination of DATAFLEX® 16 with RADEX®-NC

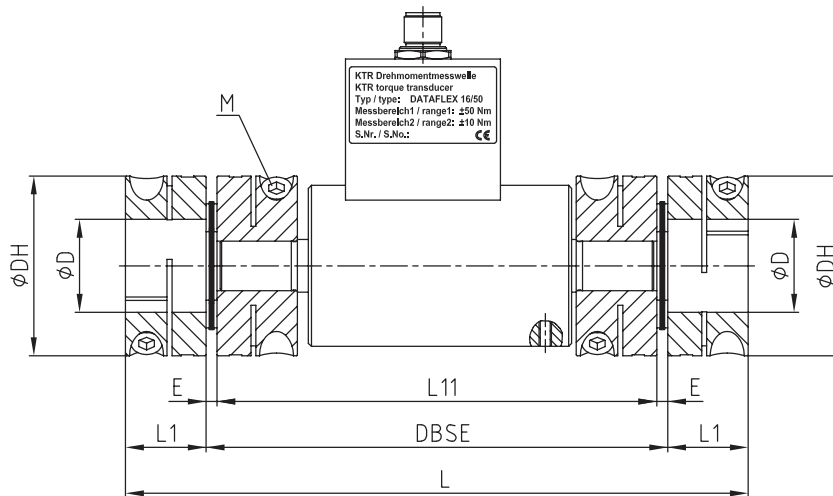

Dimensions [mm] of torque measuring shaft and combination with RADEX®-NC HT couplings

DATAFLEX® type	DW	D3	LD	L2	L3	L4	L5	L6	H	X	RADEX®-NC size	DH	D <sub>max</sub>	DBSE	L	L1	L11	E
16/10											21	58	30	149	201	26	142	3.5
16/30	16	52	140	25	90	85	3.5	50	67	12	26	69	38	166	232	33	156	5.0
16/50																		

# DATAFLEX® 32/100, 32/300, 32/500 DUAL-RANGE TORQUE SENSOR

for torques up to 500 Nm



General properties					
DATAFLEX® type	Measuring range 1 $T_{KN}$ [Nm]	Measuring range 2 $T_{KN2}$ [Nm]	Supply voltage [V]	Current consumption [mA]	Operating temperature range [°C]
32/100	-100 ... +100	-20 ... +20	24 ± 4	<100	0 ... 55
32/300	-300 ... +300	-60 ... +60			
32/500	-500 ... +500	-100 ... +100			

Technical data of torque signal				Technical data of speed signal					
DATAFLEX® type	Inaccuracy (% of $T_{KN}/T_{KN2}$ ) <sup>1), 2), 3)</sup>	Output voltage [V]	Bandwidth [kHz]	Influence of temperature <sup>1)</sup> [%/10 °C]	Resolution [pulses/rev.]	Number of channels	Square-wave signal <sup>4)</sup> [Vss]	Direct voltage signal <sup>4)</sup> [V]	Direction signal <sup>4)</sup> [V]
32/100	<0.1/0.2	-10 ... 10	2	0.05	720	2, 90° offset	5/24	0 ... 10, scalable	5/24
32/300									
32/500									

Mechanical data of torque measuring shaft										
DATAFLEX® type	Static load limit <sup>1)</sup> $T_{K \max}$ [%]	Breaking load $T_{K \text{ break}}$ <sup>1)</sup> [%]	Max. bending torque [Nm]	Max. radial force [N]	Max. axial force [kN]	Weight [kg]	Torsion spring stiffness $C_T$ [Nm/rad]	Torsion angle with $T_{KN}$ [°]	Mass moment of inertia [kgmm <sup>2</sup> ]	Max. speed <sup>5)</sup> [rpm]
32/100	150	300	11	110	5.0	1.9	18000	0.32	219	7500
32/300			32	320	10.4		46000	0.37	221	
32/500			53	530	14.6		60000	0.48	224	

Mechanical data of combination of DATAFLEX® 32 and RADEX®-NC								
DATAFLEX® type	Coupling				Mechanical data of combination			
	RADEX®-NC/ RADEX®-N size	Setscrew/clamping screw			Mass moment of inertia [kgmm <sup>2</sup> ]	Torsion spring stiffness $C_T$ [Nm/rad]	Weight [kg]	Max. speed <sup>5)</sup> [rpm]
		G	T	$T_A$ [Nm]				
32/100	RADEX®-NC 36	M10	-	49	1097	15800	3.80	7500
32/300	RADEX®-N 60	M8	20	10	17900	49000	11.65	6700
32/500								

<sup>1)</sup> Referring to  $T_{KN}$

<sup>2)</sup> Referring to  $T_{KN2}$

<sup>3)</sup> Error in linearity incl. hysteresis

<sup>4)</sup> See page 361: with connection housing DF2

<sup>5)</sup> With high speeds use coupling hubs that are balanced

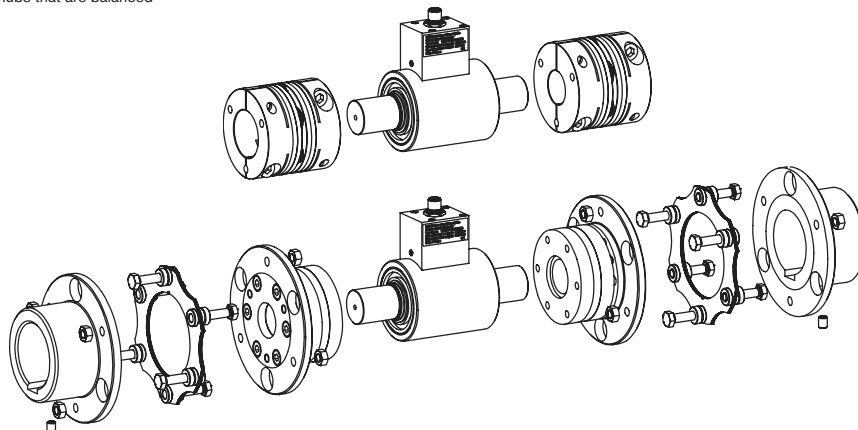

Ordering example:	DATAFLEX® 32/300	DF2	2 m, 5 m and 10 m	RADEX®-N 60 NN Ø32/50 keyway to DIN Ø32/60 keyway to DIN
	Type of measuring shaft with measuring range	Connection housing (is required)	Connection cable	If any accessories are requested: coupling type, finish bores D/DW

DATAFLEX® 32

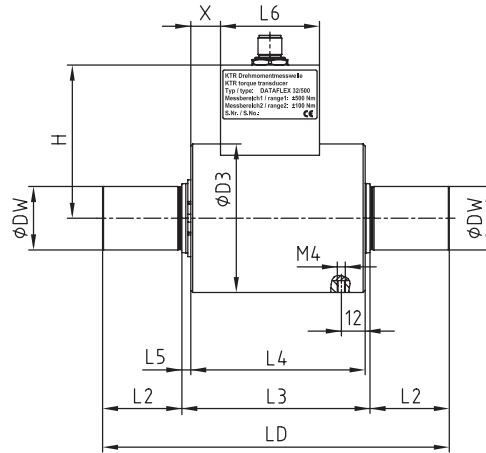

Combination of DATAFLEX® 32 with RADEX®-NC

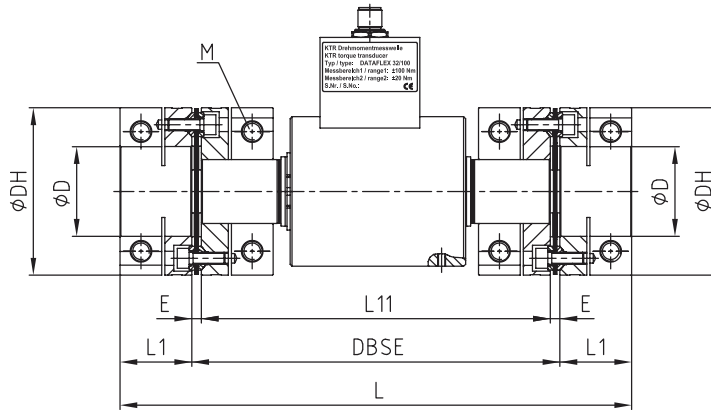

Combination of DATAFLEX® 32 with RADEX®-N

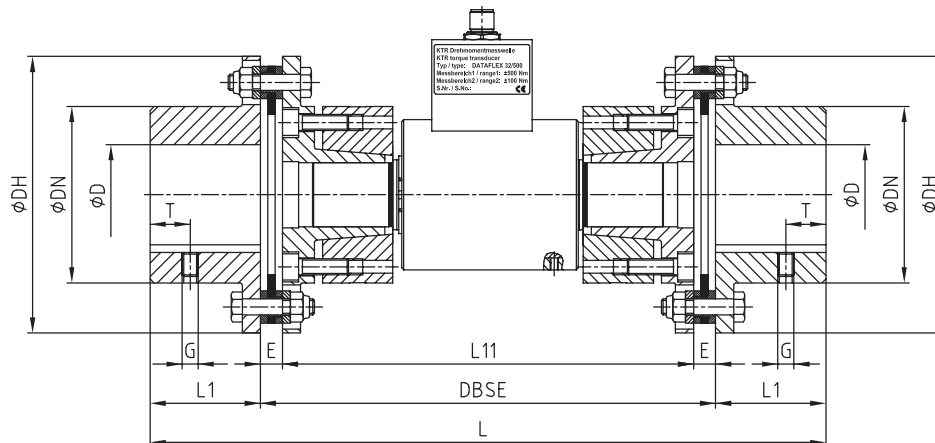

Dimensions [mm] of torque measuring shaft and combination with RADEX®-NC HT couplings

DATAFLEX® type	DW	D3	LD	L2	L3	L4	L5	L6	H	X	RADEX®-NC size	DH	D <sub>max</sub>	DBSE	L	L1	L11	E
32/100	32	75	175	40	95	88	4.5	50	77.3	15	36	84	45	184.6	256.6	36	175	4.8

Dimensions [mm] of torque measuring shaft and combination with RADEX®-N couplings

DATAFLEX® type	DW	D3	LD	L2	L3	L4	L5	L6	H	X	RADEX®-N size	DH	DN	D <sub>max</sub>	DBSE	L	L1	L11	E
32/300	32	75	175	40	95	88	4.5	50	77.3	15	60	138	88	60	227	337	55	205	11
32/500																			

# DATAFLEX® 42/1000 DUAL-RANGE TORQUE SENSOR

for torques up to 1000 Nm



For legend of pictogram refer to flapper on the cover



## General properties

DATAFLEX® type	Measuring range 1 $T_{KN1}$ [Nm]	Measuring range 2 $T_{KN2}$ [Nm]	Supply voltage [V]	Current consumption [mA]	Operating temperature range [°C]
42/1000	-1000 ... +1000	-200 ... +200	24 ±4	< 100	0 ... 55

Technical data of torque signal					Technical data of speed signal				
DATAFLEX® type	Inaccuracy (% of $T_{KN1}/T_{KN2}$ ) <sup>1), 2), 3)</sup>	Output voltage [V]	Bandwidth [kHz]	Influence of temperature <sup>1)</sup> [%/10 °C]	Resolution [pulses/rev.]	Number of channels	Square-wave signal <sup>4)</sup> [Vss]	Direct voltage signal <sup>4)</sup> [V]	Direction signal <sup>4)</sup> [V]
42/1000	<0.1 / 0.2	-10 ... 10	2	0.05	720	2, 90° offset	5 / 24	0 ... 10, scalable	5 / 24

## Mechanical data of torque measuring shaft

DATAFLEX® type	Static load limit <sup>1)</sup> $T_{K \max}$ [%]	Breaking load $T_{K \text{ break}}$ [%] <sup>1)</sup>	Max. bending torque [Nm]	Max. radial force [N]	Max. axial force [kN]	Weight [kg]	Torsion spring stiffness $C_T$ [Nm/rad]	Torsion angle with $T_{KN}$ [°]	Mass moment of inertia [kgmm <sup>2</sup> ]	Max. speed <sup>5)</sup> [rpm]
42/1000	150	300	107	780	24	3.43	132000	0.43	710	6500

## Mechanical data of torque measuring shaft and combination with RADEX®-N couplings

DATAFLEX® type	Coupling				Mechanical data of combination			
	RADEX®-N size	Setscrew			Mass moment of inertia [kgmm <sup>2</sup> ]	Torsion spring stiffness $C_T$ [Nm/rad]	Weight [kg]	Max. speed <sup>5)</sup> [rpm]
		G	T	$T_A$ [Nm]				
42/1000	80	M10	20	17	61000	107000	23.1	5100

<sup>1)</sup> Referring to  $T_{KN}$

<sup>2)</sup> Referring to  $T_{KN2}$

<sup>3)</sup> Error in linearity incl. hysteresis

<sup>4)</sup> See page 361 : with connection housing DF2

<sup>5)</sup> With high speeds use coupling hubs that are balanced

Ordering example:	DATAFLEX® 42/1000	DF2	2 m, 5 m and 10 m	RADEX®-N 80 NN Ø42/50 keyway to DIN Ø42/60 keyway to DIN
	Type of measuring shaft with measuring range	Connection housing (is required)	Connection cable	If any accessories are requested: coupling type, finish bores D/DW

## Components

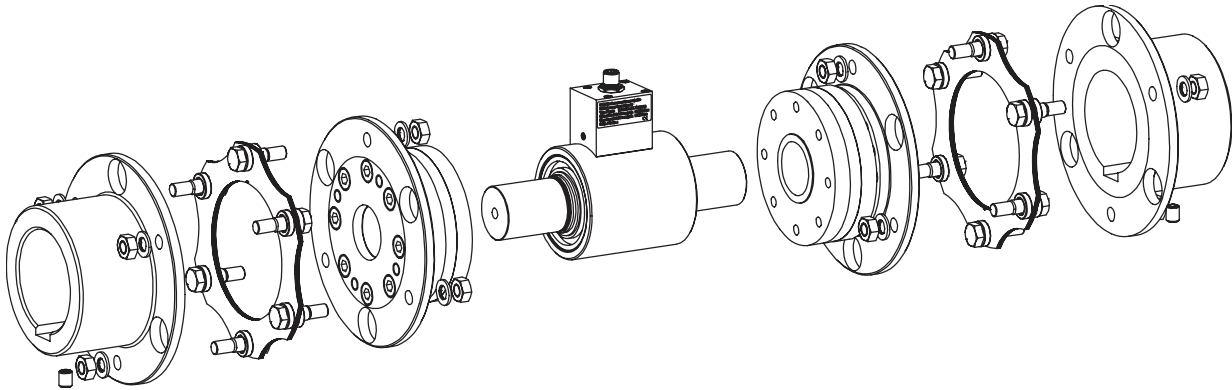

DATAFLEX® 42

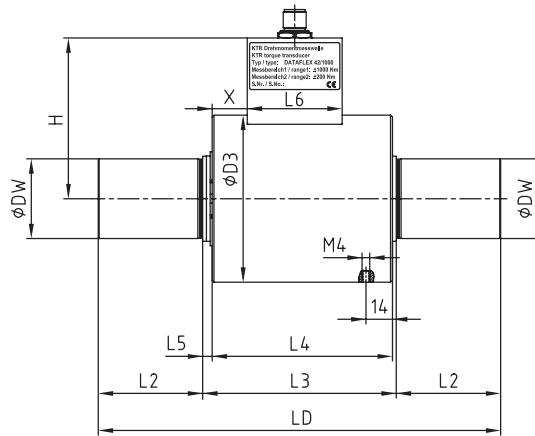

Combination of DATAFLEX® 42 with RADEX®-N

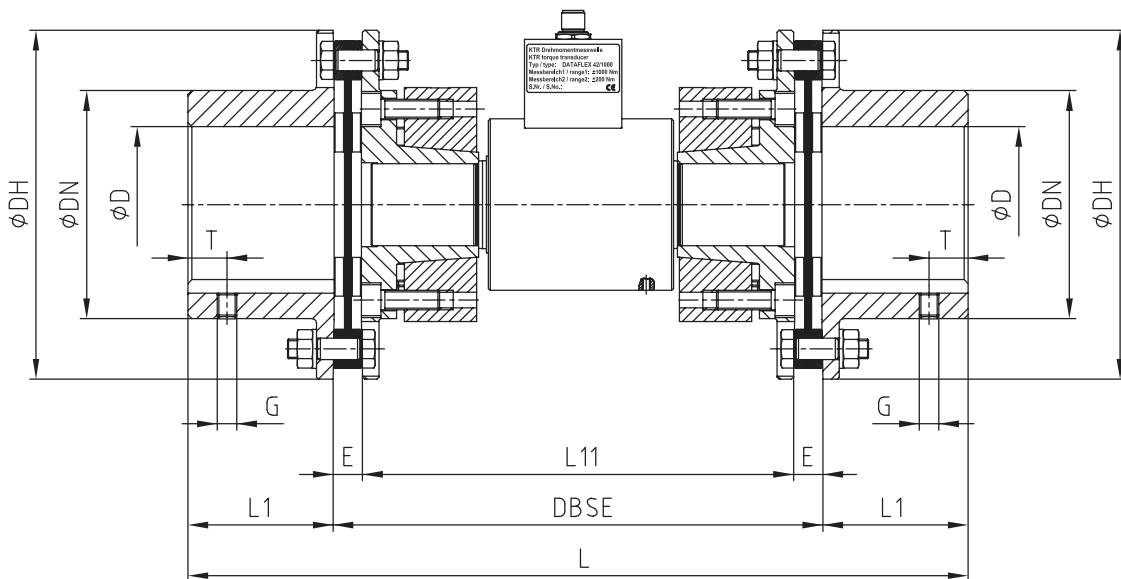

Dimensions [mm] of torque measuring shaft and combination with RADEX®-N couplings

DATAFLEX® type	DW	D3	LD	L2	L3	L4	L5	L6	H	X	RADEX®-N size	DH	DN	D <sub>max</sub>	DBSE	L	L1	L11	E
42/1000	42	88	212	55	102	95	5	50	84.7	18.5	80	179	117	80	250	400	75	222	14

# DATAFLEX® 70/3000, 70/5000 DUAL-RANGE TORQUE SENSOR

for torques up to 5000 Nm



For legend of pictogram refer to flapper on the cover



General properties										
DATAFLEX® type	Measuring range 1 T <sub>KN</sub> [Nm]	Measuring range 2 T <sub>KN2</sub> [Nm]	Supply voltage [V]	Current consumption [mA]	Operating temperature range [°C]					
70/3000	-3000 ... +3000	-600 ... +600	24 ± 4	< 100	0 ... 55					
70/5000	-5000 ... +5000	-1000 ... +1000								
Technical data of torque signal					Technical data of speed signal					
DATAFLEX® type	Inaccuracy (% of T <sub>KN</sub> /T <sub>KN2</sub> ) <sup>1), 2), 3)</sup>	Output voltage [V]	Bandwidth [kHz]	Influence of temperature <sup>1)</sup> [%/10 °C]	Resolution [pulses/rev.]	Number of channels	Square-wave signal <sup>4)</sup> [V <sub>ss</sub> ]	Direct voltage signal <sup>4)</sup> [V]	Direction signal <sup>4)</sup> [V]	
70/3000	< 0.1/0.2	-10 ... 10	2	0.05	450	2, 90° offset	5/24	0 ... 10, scalable	5/24	
70/5000										
Mechanical data of torque measuring shaft										
DATAFLEX® type	Static load limit <sup>1)</sup> T <sub>K max</sub> [%]	Breaking load T <sub>K break</sub> <sup>1)</sup> [%]	Max. bending torque [Nm]	Max. radial force [N]	Max. axial force [kN]	Weight [kg]	Torsion spring stiffness C <sub>T</sub> [Nm/rad]	Torsion angle with T <sub>KN</sub> [°]	Mass moment of inertia [kgmm <sup>2</sup> ]	Max. speed <sup>5)</sup> [rpm]
70/3000	150	300	320	1700	48	12.30	395000	0.44	7200	4000
70/5000			520	2800	66	12.45	500000	0.57	7300	
Mechanical data of combination of DATAFLEX® 70 and RADEX®-N										
DATAFLEX® type	Coupling				Mechanical data of combination					
	RADEX®-N size	Setscrew			Mass moment of inertia [kgmm <sup>2</sup> ]	Torsion spring stiffness C <sub>T</sub> [Nm/rad]	Weight [kg]	Max. speed <sup>5)</sup> [rpm]		
G		T	T <sub>A</sub> [Nm]							
70/3000	90	M12	25	40	155200	283000	44.7	4000		
70/5000	115	M12	30	40	470000	389000	77.6	3400		

<sup>1)</sup> Referring to T<sub>KN</sub>

<sup>2)</sup> Referring to T<sub>KN2</sub>

<sup>3)</sup> Error in linearity incl. hysteresis

<sup>4)</sup> See page 361: with connection housing DF2

<sup>5)</sup> With high speeds use coupling hubs that are balanced

Ordering example:	DATAFLEX® 70/5000	DF2	2 m, 5 m and 10 m	RADEX®-N 115 NN Ø65/60 keyway to DIN Ø65/70 keyway to DIN
	Type of measuring shaft with measuring range	Connection housing (is required)	Connection cable	If any accessories are requested: coupling type, finish bores D/DW

Components

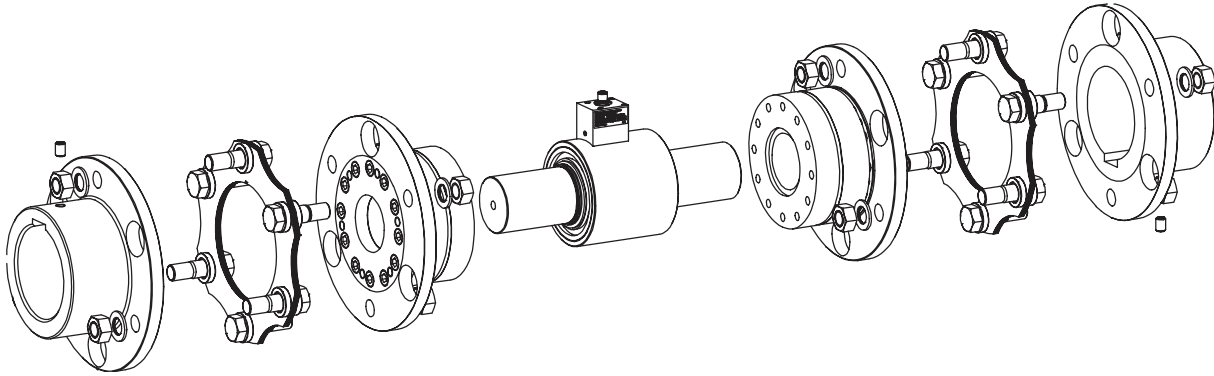

DATAFLEX® 70

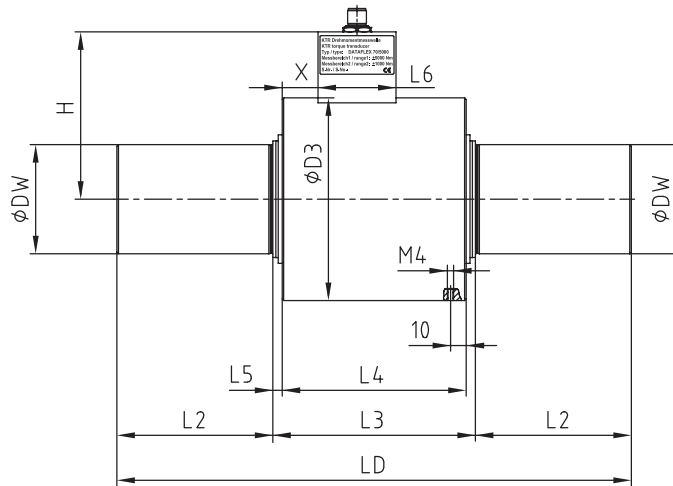

Combination of DATAFLEX® 70 with RADEX®-N

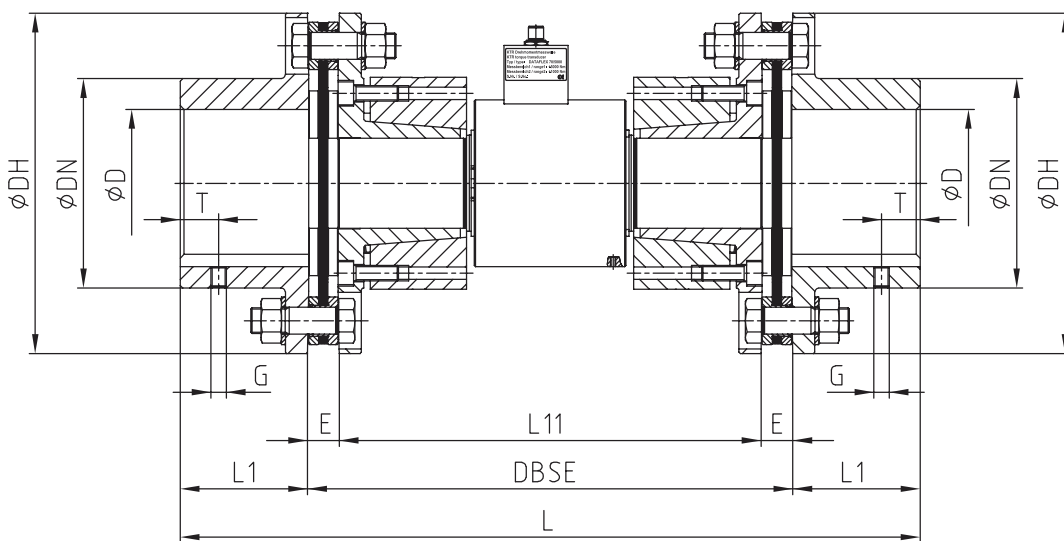

Dimensions [mm] of torque measuring shaft and combination with RADEX®-N couplings

DATAFLEX® type	DW	D3	LD	L2	L3	L4	L5	L6	H	X	RADEX®-N size	DH	DN	D <sub>max</sub>	DBSE	L	L1	L11	E
70/3000	70	130	330	100	130	118	6	50	107.35	23	90	210	132	90	360	520	80	330	15
70/5000											115	265	163	115	376	576	100		23

# DATAFLEX® 110/10000, 110/20000 DUAL-RANGE TORQUE SENSOR

for torques up to 20000 Nm



For legend of pictogram refer to flapper on the cover



## DATAFLEX® 110

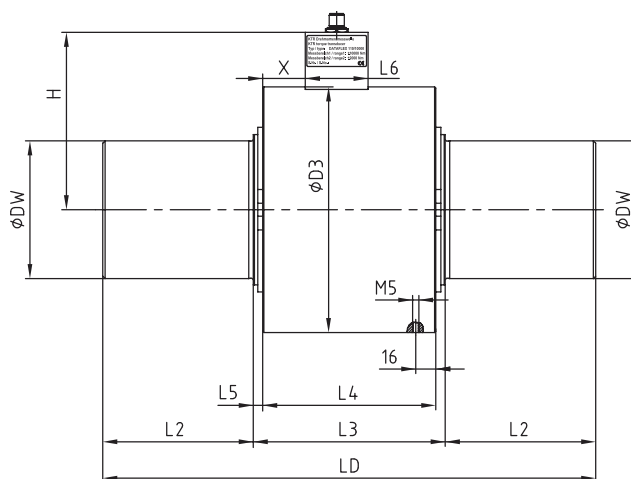

### General properties

DATAFLEX® type	Measuring range 1 $T_{KN}$ [Nm]	Measuring range 2 $T_{KN2}$ [Nm]	Supply voltage [V]	Current consumption [mA]	Operating temperature range [°C]
110/10000	- 10000 ... + 10000	- 2000 ... + 2000	24 ± 4	< 100	0 ... 55
110/20000	- 20000 ... + 20000	- 4000 ... + 4000			

### Technical data of torque signal

### Technical data of speed signal

DATAFLEX® type	Inaccuracy (% of $T_{KN}/T_{KN2}$ ) <sup>1), 2), 3)</sup>	Output voltage [V]	Bandwidth [kHz]	Influence of temperature <sup>1)</sup> [%/10 °C]	Resolution [pulses/rev.]	Number of channels	Square-wave signal <sup>4)</sup> [Vss]	Direct voltage signal <sup>4)</sup> [V]	Direction signal <sup>4)</sup> [V]
110/10000	< 0.1/0.2	-10 ... +10	2	0.05	720	2, 90° offset	5/24	0 ... 10,	5/24
110/20000								scalable	

### Mechanical data of torque measuring shaft

DATAFLEX® type	Static load limit <sup>1)</sup> $T_{K \max}$ [%]	Breaking load $T_{K \text{ break}}$ [%]	Max. bending torque [Nm]	Max. radial force [N]	Max. axial force [kN]	Weight [kg]	Torsion spring stiffness $C_T$ [Nm/rad]	Torsion angle with $T_{KN}$ [°]	Mass moment of inertia [kgm <sup>2</sup> ]	Max. speed <sup>5)</sup> [rpm]
110/10000	150	300	1033	4700	106	35.72	2270000	0.25	0.0562	3000
110/20000			2037	9300	166	36.20	3550000	0.32	0.0569	

### Dimensions [mm] of torque measuring shaft

DATAFLEX® type	DW	D3	LD	L2	L3	L4	L5	L6	H	X
110/10000	110	196	393	120	153	138	7.5	50	141.4	34
110/20000										

<sup>1)</sup> Referring to  $T_{KN}$

<sup>2)</sup> Referring to  $T_{KN2}$

<sup>3)</sup> Error in linearity incl. hysteresis

<sup>4)</sup> See page 361: with connection housing DF2

<sup>5)</sup> With high speeds use coupling hubs that are balanced

**Ordering example:**

DATAFLEX® 110/10000	DF2	2 m, 5 m and 10 m
Type of measuring shaft with measuring range	Connection housing (is required)	Connection cable

# DATAFLEX® CONNECTION ACCESSORIES OF TORQUE MEASURING SHAFTS

## Connection housing DF2 and connection cable



DATAFLEX®

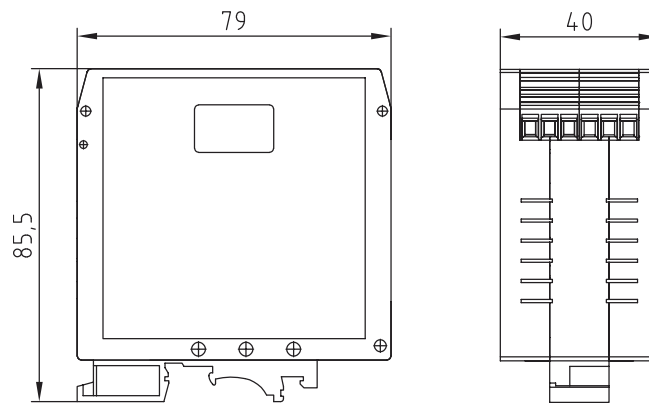

Connection cable and connection housing DF2

Description	Function	DATAFLEX® 16	DATAFLEX® 32	DATAFLEX® 42	DATAFLEX® 70	DATAFLEX® 110
<b>Connections DF2</b>						
<b>Input of operating voltage</b>						
24 V	Supply voltage +	24 V DC ± 4V / 100mA max.				
GND	Supply voltage -					
<b>Torque output</b>						
M-U	Voltage output +	-10 V ... 10V				
GND		Ground of torque output				
M-I	Current output	-	-	-	-	-
<b>Speed output pulse signal</b>						
N1	Pulsed output speed track 1	HTL, TTL (24 V, 5 V, 360 pulses/rev.)	HTL, TTL (24 V, 5 V, 720 pulses/rev.)	HTL, TTL (24 V, 5 V, 720 pulses/rev.)	HTL, TTL (24 V, 5 V, 450 pulses/rev.)	HTL, TTL (24 V, 5 V, 720 pulses/rev.)
GND		Ground of pulsed output				
N2	Pulsed output speed track 2	HTL, TTL (24 V, 5 V, 360 pulses/rev.)	HTL, TTL (24 V, 5 V, 720 pulses/rev.)	HTL, TTL (24 V, 5 V, 720 pulses/rev.)	HTL, TTL (24 V, 5 V, 450 pulses/rev.)	HTL, TTL (24 V, 5 V, 720 pulses/rev.)
<b>Speed of direct voltage output</b>						
R/L	Direction signal speed	HTL, TTL (24 V, 5 V, CW = 1)				
GND		Mass of direct voltage output speed				
N-U	Voltage output speed	0 V ... 10 V (scalable)				
<b>Other connections / operating devices</b>						
T1	Push button T1 - connection	External push button connection T1				
L1, L2	Signal LEDs	Condition monitoring				
T1, T2	Push button T1, T2	Push button for programming				
TP	Switch low pass	Filter for torque signal to be set in four levels				
<b>Connection cable</b>						
Lengths of connection cable		2, 5, 10 m, other lengths on request				

# MONITEX® BT 28/200, 42/800 TORQUE MEASURING COUPLING HUB

For torques of 200 Nm and 800 Nm



For legend of pictogram refer to flapper on the cover



## General properties

MONITEX® BT type	Coupling type	Supply voltage <sup>2)</sup> [V]	Current consumption <sup>2)</sup> [mA]	Operating temperature range [°C]
28/200	ROTEX® GS 28	24 ± 4	<200	0 ... 55
42/800	ROTEX® GS 42			

## Technical data of torque signal

MONITEX® BT type	Measuring range $T_{KN}$ [Nm]	Inaccuracy [% of $T_{KN}$ ]	Measuring frequency of App/Windows software/DAC [Hz]	Influence of temperature <sup>1)</sup> [%/10 °C]	Measuring range [rpm]	Resolution [rpm]	Measuring frequency of App/Windows software/DAC [Hz]	Number of digits of torque	Number of digits of speed	Switch-on threshold [rpm]
28/200	-200 ... +200	±0.25	60/500/500	0.05	30-3500	1	3/5/5	3+1 decimals + ± sign	4	300
42/800	-800 ... +800									

## Technical data of speed signal

## Technical data of display

## Mechanical data of the coupling hub

MONITEX® BT type	Static load limit <sup>1)</sup> $T_K$ max [%]	Breaking load $T_K$ break <sup>1)</sup> [%]	Max. bending torque [Nm]	Max. radial force [N]	Max. axial force [kN]	Weight [kg]	Torsion spring stiffness $C_T$ [Nm/rad]	Torsion angle with $T_{KN}$ [degrees]	Mass moment of inertia [kgmm <sup>2</sup> ]	Max. speed [rpm]
28/200	150	300	22	250	8	0.84	46000	0.25	765	3500
42/800			86	700	20	1.72	194000	0.24	2690	

<sup>1)</sup> Referring to rated torque  $T_{KN}$

<sup>2)</sup> MONITEX® BT inductive head

## MONITEX® BT measuring coupling with coupling flange

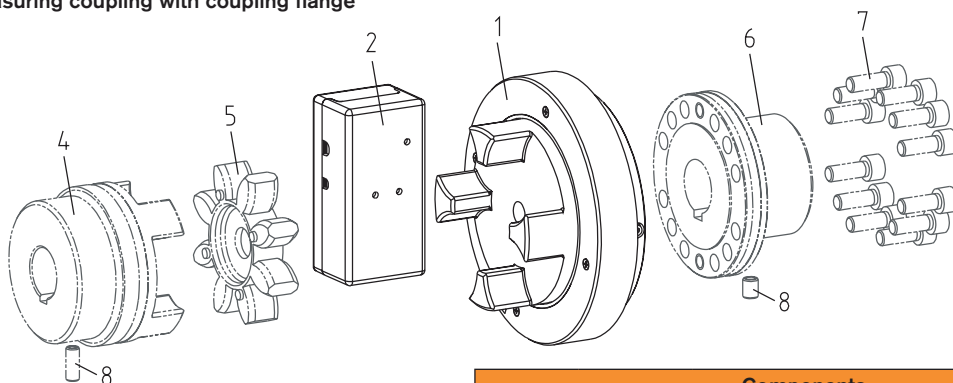

## Components

Component	Quantity	Subassembly
1	1	MONITEX® BT measuring hub
2	1	MONITEX® BT inductive head (inductive current transmission)
3 <sup>1)</sup>	1	MONITEX® BT connection cable
4 <sup>2)</sup>	1	ROTEX®/ROTEX® GS hub
5 <sup>2)</sup>	1	ROTEX® GS spider
6 <sup>2)</sup>	1	ROTEX® coupling flange N
7 <sup>2)</sup>	see page 355	Cap screws DIN EN ISO 4762 - 12.9
8 <sup>2)</sup>	2	Setscrew DIN EN ISO 4029
9 <sup>1) 2)</sup>	1	DAC (digital-to-analog-converter), see page 380

<sup>1)</sup> not graphically shown in the left image

<sup>2)</sup> Optionally available

## Ordering example:

MONITEX® BT 42/800	Inductive head	2 m	Ø38	ROTEX® GS 2.5 - Ø38	98 ShA-GS
Measuring hub size	Inductive power supply	Connection cable	ROTEX® coupling flange N, finish bore	Hub type, finish bore	Spider hardness, see catalogue page 127

Components

MONITEX® BT measuring coupling

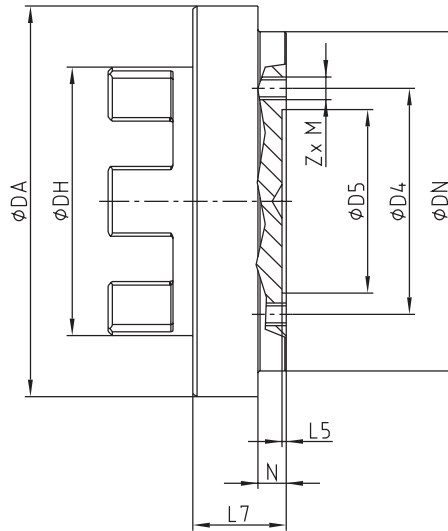

Dimensions [mm]									
MONITEX® BT type	DA	DH	DN	D4	D5	L5	L7	N	Z x M
28/200	112.4	65	90	54	44	1.5	28	10	8 x M6
42/800	138.4	95	120	80	65	1.5	33	10	12 x M8

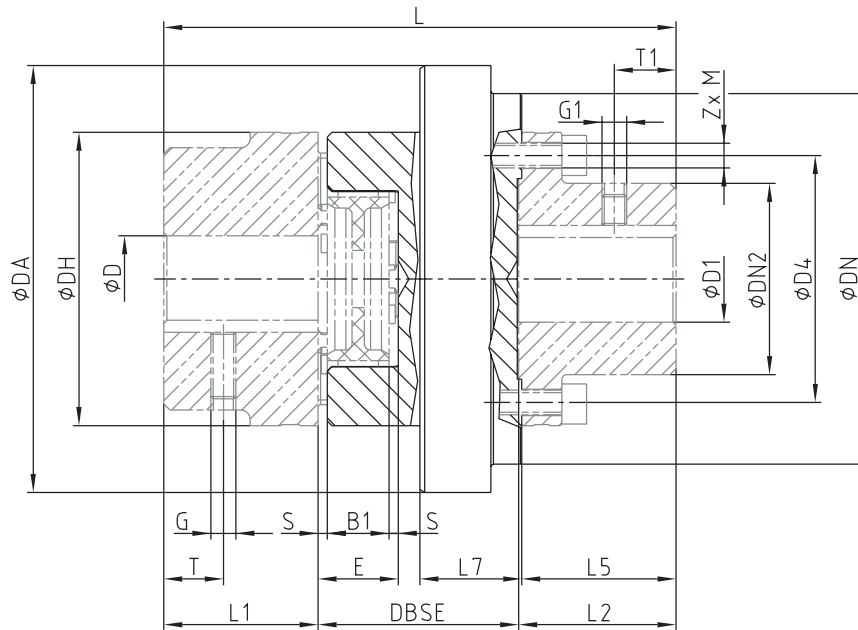

Dimensions in mm									
MONITEX® BT type	ROTEX® GS size	Max. finish bore <sup>1)</sup>		DA	DH	DBSE	DN	DN2	D4
		D	D1						
28/200	28	38	30	112.4	65	54.5	90	42	54
42/800	42	55	45	138.4	95	65.0	120	62	80

<sup>1)</sup> Special hubs on request

Dimensions in mm											
MONITEX® BT type	L	L1	L2	L5	L7	E	B1	S	Cap screws DIN EN ISO 4762		
									Number Z	M	T <sub>A</sub> [Nm]
28/200	125	35	35.5	35	28	20	15	2.5	8	M6	17
42/800	166	50	51.0	50	33	26	20	3.0	12	M8	41

Setscrew DIN EN ISO 4029		
Size	28	42
Dimension G, G1 in mm	M8	M8
Dimension T, T1 in mm	15	20
Tightening torque T <sub>A</sub> [Nm]	10	10

# MONITEX® BT ACCESSORIES (TORQUE MEASURING COUPLING HUB)

## DAC – analog output

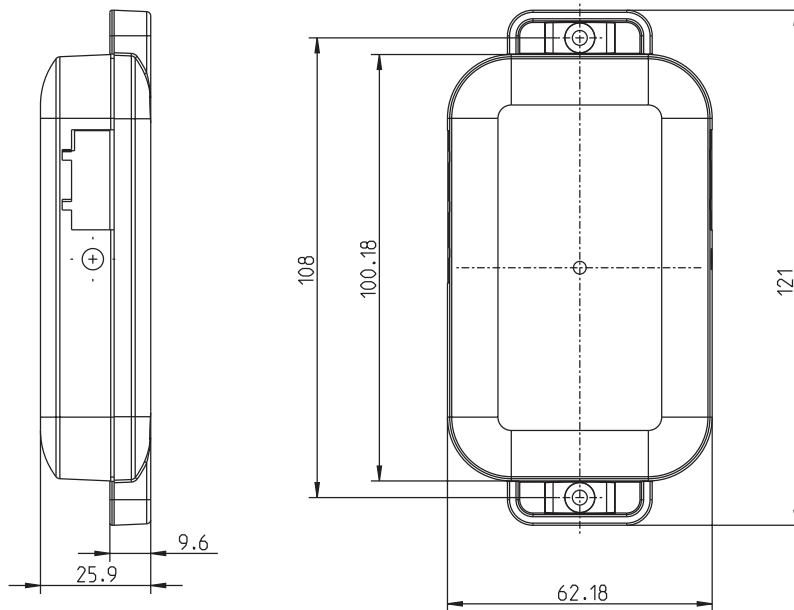

The digital-to-analog converter (DAC) automatically connects to the torque measuring MONITEX® BT coupling hub displaying the torque and speed data as analog voltage and current. Besides the free app and Windows software, the signals can be directly connected to controls or existing data logging.

Electrical data		Output resistances	
Power supply [V DC]	24 ±4	Voltage outputs [Ohm]	1000
Max. current consumption [mA]	<100	Maximum current loop resistance [Ohm]	Max. 560
Torque outputs		Inaccuracies of converter	
Voltage output [V]	-10 ... +10	Voltage outputs <sup>1)</sup> [%]	0.05
Current output [mA]	4 ... 20	Current outputs <sup>1)</sup> [%]	0.1
Converter frequency [Hz]	500		
Torque outputs		Dimensions	
Voltage output [V]	0 ... 10	Dimensions [mm]	121 x 62 x 26
Current output [mA]	4 ... 20	Weight [g]	90
Converter frequency [Hz]	5		

<sup>1)</sup> Referring to upper range value

Scaling				
Type MONITEX® BT	Torque		Speed	
	Voltage output [Nm/V]	Current output [Nm/mA]	Voltage output [rpm/V]	Current output [rpm/mA]
MONITEX® BT 28	20	25	350	218.75
MONITEX® BT 42	80	100		



# Summary of literature

No matter if a perfect drive, a brake that takes effect, space-saving cooling or accurate hydraulics is required, if on land, by sea or at an airy height - KTR's product portfolio is just as manifold as its applications. The following catalogues and leaflets provide an overview. Available at [www.ktr.com](http://www.ktr.com)

## Product catalogues



## ATEX leaflet

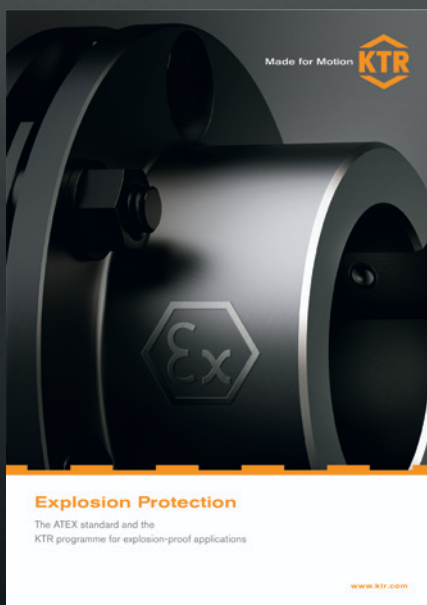

## Company leaflet



Made for Motion **KTR**

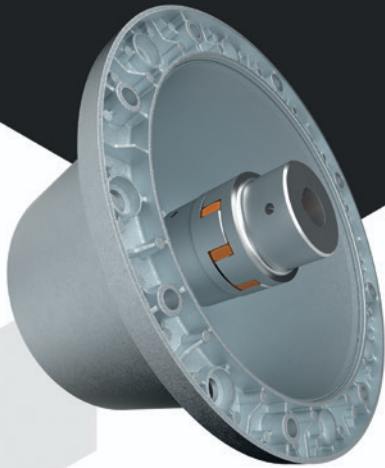

### Hydraulic components

Bellhousings  
Damping elements  
Cooling systems  
Oil tanks

[www.ktr.com](http://www.ktr.com)

Made for Motion **KTR**



### Cooling systems

For mobile machines and stationary hydraulics  
Customised solutions or standard design

[www.ktr.com](http://www.ktr.com)

# KTR Germany:

## Headquarters:

### KTR Systems GmbH

Carl-Zeiss-Straße 25  
D-48432 Rheine

Phone: +49 5971 798-0  
Fax: +49 5971 798-698 or 798-450  
E-mail: mail@ktr.com  
Internet: www.ktr.com

## KTR Brake Systems GmbH

Competence Center for Brake Systems  
Zur Brinke 14  
D-33758 Schloß Holte-Stukenbrock  
Phone: +49 5207 99161-0

## Head of Sales

Lino Gioroglou  
Phone: +49 5207 991 61-72  
Mobile: +49 160 90 58 97 41  
E-mail: l.gioroglou@ktr.com

## Sales representative industrial brakes

Adam Krzykowski  
Mobile: +49 172 58 59 44 8  
E-mail: a.krzykowski@ktr.com

## Außendienst Norddeutschland für Hydraulik-Komponenten

Gunnar Ehlers  
Finkenstieg 4b  
21629 Neu Wulmstorf  
Mobile: +49 174 3301536  
E-mail: g.ehlers@ktr.com

## Außendienst Bayern, Baden-Württemberg und Österreich für Hydraulik-Komponenten

Klaus-Peter Sprödhuber  
Blumenstraße 6  
95499 Harsdorf  
Phone: +49 9203 9739450  
Mobile: +49 172 1096496  
E-mail: k.sproedhuber@ktr.com

## Schleswig-Holstein, Nord-Niedersachsen, Hamburg, Bremen

Martin Lau, Maschinenbautechniker  
KTR Ingenieurbüro Hamburg  
Geschwister-Scholl-Allee 44  
25524 Itzehoe

Phone: +49 4821 4050812  
Mobile: +49 172 5310014  
E-mail: m.lau@ktr.com

## NRW: Ruhrgebiet, Großraum Düsseldorf, Köln, Aachen

KTR Ingenieurbüro Rheine  
John Wein,  
B. Sc. Wirtschaftsingenieurwesen  
Carl-Zeiss-Straße 25  
48432 Rheine  
Phone: +49 5971 798 7437  
Mobile: +49 151 62489605  
E-mail: j.wein@ktr.com

## Emsland, Mitte- und Süd-Niedersachsen, Ostwestfalen

KTR Ingenieurbüro Rheine  
Rainer Lüttmann  
KTR Systems GmbH  
Carl-Zeiss-Straße 25  
48432 Rheine  
Phone: +49 5971 798-340  
Mobile: +49 172 5322164  
E-mail: r.luettmann@ktr.com

## NRW: Süd, Westfalen und Nordhessen

René Szabó,  
Techniker u. techn. Betriebswirt (IHK)  
Waldstr. 67  
57080 Siegen-Niederschelden  
Phone: +49 5971 798 7777  
Mobile: +49 175 81 64 844  
E-mail: r.szabo@ktr.com

## Hessen, Rheinland-Pfalz, Saarland

Martin Dietrich, Ingenieur Maschinenbau  
KTR Ingenieurbüro Frankfurt  
Schorbachstr. 9  
35510 Butzbach  
Phone: +49 6033 9248494  
Mobile: +49 172 5329968  
E-mail: m.dietrich@ktr.com

## Berlin, Mecklenburg-Vorpommern Südost, Sachsen-Anhalt, Brandenburg Thüringen Nord, Sachsen

Norman Schlag, Tech. BW (IHK)  
KTR Ingenieurbüro Leipzig  
Hauptstraße 101  
04416 Markkleeberg  
Phone: +49 341 35416467  
Mobile: +49 173 4716266  
E-mail: n.schlag@ktr.com

## Baden-Württemberg Nord

Eberhard Maier, Dipl.-Ing. (FH)  
Hortensienweg 1  
70374 Stuttgart, Sommerrain  
Phone: +49 711 65842957  
Mobile: +49 172 5355056  
E-mail: e.maier@ktr.com

## Baden-Württemberg Süd

Jochen Glöckler, Maschinenbautechniker  
KTR Ingenieurbüro Balingen  
Hölzlestraße 44  
72336 Balingen  
Phone: +49 7433 91381  
Mobile: +49 172 5310049  
E-mail: j.gloeckler@ktr.com

## Bayern-Nord, Thüringen Süd

Alexander Ennulat, Dipl.-Ing. (FH)  
KTR Ingenieurbüro Römerstein  
Grabenstetter Str. 28  
72587 Römerstein  
Phone: +49 7382 9369226  
Mobile: +49 162 4160354  
E-mail: a.ennulat@ktr.com

## Bayern-Süd, Baden-Württemberg Ost

Peter Benkard, Dipl.-Ing. (FH)  
KTR Ingenieurbüro Adelsried  
Am Mittelfeld 13  
86477 Adelsried  
Phone: +49 8293 9605-04  
Mobile: +49 172 5313059  
E-mail: p.benkard@ktr.com

For all representatives and sales partners refer to [www.ktr.com](http://www.ktr.com).

# KTR worldwide:

## Algeria

KTR Algérie

Phone: +213 661 92 24 00

Phone: +33 4 78 64 54 66

E-mail: ktr-dz@ktr.com

## Brazil

KTR do Brasil Ltda

Rua Apucarana, 454

Bairro Emiliano Perneta

Pinhais – PR – Cep: 83324-450

Phone: +55 41 36 69 57 13

E-mail: ktr-br@ktr.com

## Chile

KTR Systems Chile SpA

ICENTER

Av. La Vilana 18501

Bodega B-8

9380000 Lampa

Phone: +56 23 22 46 674

E-mail: ktr-cl@ktr.com

## China

KTR Power Transmission Systems

(Zhejiang) Co., Ltd.

No. 3077, Xinda Road,

Daqiao Town, Nanhu District,

Jiaxing City, Zhejiang Province

Phone: +86 0573 8260 1800

E-mail: ktr-cn@ktr.com

## Czech Republic

KTR CR, spol. s r.o.

Brněnská 559

569 43 Jevíčko

Czech Republic

Phone: +420 461 325 014

E-mail: ktr-cz@ktr.com

## Denmark

KTR Systems Danmark ApS

Vejlsøvej 51, Bygning N

8600 Silkeborg

Phone: +45 39 39 10 50

E-mail: ktr-dk@ktr.com

## Finland

KTR Finland OY

Tiistiniityntie 4

FIN-02230 Espoo

Phone: +358 2 07 41 46 10

E-mail: ktr-fi@ktr.com

## France

KTR France SAS

5 Chemin de la Brocardière

CS 71359

F-69573 DARDILLY CEDEX

Phone: +33 4 78 64 54 66

E-mail: ktr-fr@ktr.com

## India

KTR Couplings (India) Pvt. Ltd.,

T - 36 / 37 / 38 / 39, MIDC Bhosari,

Pune Maharashtra 411026

Phone: +91 20 27 12 73 24/25

Fax: +91 20 27 12 73 23

E-mail: ktr-in@ktr.com;

india.sales@ktr.com

## Italy

KTR Systems GmbH

Sede Secondaria Italia

Via Augusto Pulega 1/c

I - 40133 Bologna (BO)

Phone: +39 051 613 32 32

Fax: +39 051 29855 77

E-mail: ktr-it@ktr.com

## Japan

KTR Japan Co., Ltd.

c/o The Sumitomo Warehouse Co., Ltd.

Kobe Branch, Chuo Logistics Center L-6

7-14 Minatojima, Chuo-ku, Kobe City,

Hyogo 650-0045 Japan

Phone: +81 78 381 84 01

Fax: +81 78 945 85 60

E-mail: ktr-jp@ktr.com

## Korea

KTR Korea Ltd.

#604, Songwon bldg., 89-10,

Galmaejungang-ro, Guri-si,

Gyeonggi-do, 11901 Korea

Phone: +82 3 15 69 45 10

Fax: +82 3 15 69 45 25

E-mail: ktr-kr@ktr.com

## Netherlands / Belgium / Luxembourg

KTR Benelux B. V.

Oosterveldsingel 3

7558 PJ Hengel (O)

Phone: +31 74 25 53 68 0

E-mail: ktr-nl@ktr.com

## Norway

KTR Systems Norge AS

Lahaugmoveien 81

N-2013 Skjetten

Phone: +47 64 83 54 90

E-mail: ktr-no@ktr.com

## Poland

KTR-Polska Sp. z o.o.

ul. Miłkowskiego 7/LU6

30-349 Kraków

Phone: +48 12 268 00 66

E-mail: ktr-pl@ktr.com

## Singapore

KTR Systems Singapore Pte. Ltd.

2 Venture Drive

#13-02 Vision Exchange

Singapore 608526

Phone: +65 69 04 12 32

Mobile: +65 96 33 66 92

E-mail: a.low@ktr.com

## South Africa

KTR Couplings SA (Pty) Ltd.

28 Spartan Road, Spartan Ext. 21,

Kempton Park, Johannesburg,

Gauteng

Phone: +27 87 260 6263/4

Mobile: +27 82 922 4365

E-mail: ktr-za@ktr.com

## Spain and Portugal

KTR Systems GmbH

Estartetxe, nº 5-Oficina 322

E-48940 Leioa (Vizcaya)

Phone: +34 9 44 80 39 09

E-mail: ktr-es@ktr.com

## Sweden

KTR Sverige AB

Kivra: 556585-4071

S-106 31 Stockholm

Phone: +46 8 6250290

E-mail: info.se@ktr.com

## Switzerland

KTR Systems Schweiz AG

Bahnstr. 60

CH-8105 Regensdorf

Phone: +41 43 311 15 55

Fax: +41 43 311 15 56

E-mail: ktr-ch@ktr.com

## Taiwan

KTR Systems Ltd.

No. 30-1, Gongyequ 36th Rd., Xitun Dist.,

Taichung City 40768, Taiwan (R.O.C)

Phone: +886 4 23 59 32 78

Fax: +886 4 23 59 75 78

E-mail: ktr-tw@ktr.com

## Turkey

KTR Turkey

Güç Aktarma Sistemleri San.Tic.Ltd.Sti.

Sti. Kayışdağı Cad. No: 117/2

34758 Atasehir -Istanbul

Phone: +90 216 574 37 80

E-mail: ktr-tr@ktr.com

## United Kingdom

KTR U.K. Ltd.

Robert House

Unit 7, Acorn Business Park

Woodseats Close

Sheffield

United Kingdom, S8 0TB

Phone: +44 11 42 58 77 57

Fax: +44 11 42 58 77 40

E-mail: ktr-uk@ktr.com

## USA

KTR Corporation

122 Anchor Road

Michigan City, Indiana 46360

Phone: +1 2 19 8 72 91 00

Fax: +1 2 19 8 72 91 50

E-mail: ktr-us@ktr.com



**Headquarters**  
**KTR Systems GmbH**  
Carl-Zeiss-Straße 25  
D-48432 Rheine  
Phone: +49 5971 798-0  
E-mail: [mail@ktr.com](mailto:mail@ktr.com)  
Internet: [www.ktr.com](http://www.ktr.com)

Made for Motion



# Certificates and Approvals

Being one of the first companies in the field of drive technology, KTR was certified in accordance with DIN EN ISO 9001 already in 1993, including the plants in Poland, China, India and USA.

Currently KTR products have been approved by numerous internationally renowned societies for standardization and classification. Individual approvals by other societies can be implemented on request without fail.

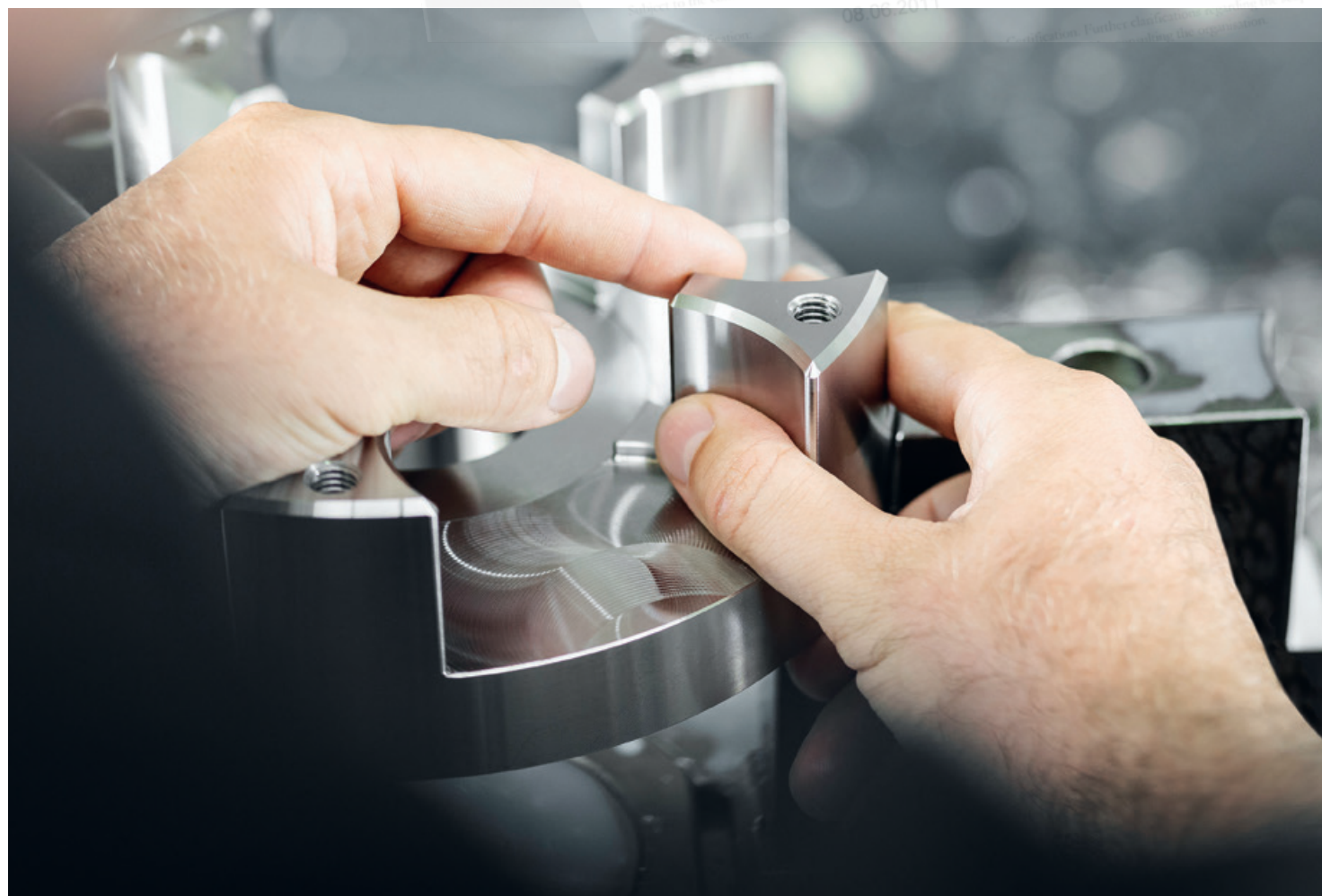

# Legend of pictograms



torsionally stiff



Light-weight



maintenance-free



torsionally flexible

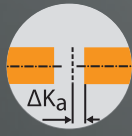

Axial compensation



Protected against corrosion



Highly flexible



Angular compensation



Electrically insulating



Damping vibrations

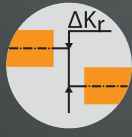

Radial compensation



Maximum speed



Axial plug-in



Shiftable at standstill



No eddy current losses



Consider shaft distance



double-cardanic



Torque limiter slipping



Relatively short shaft distance

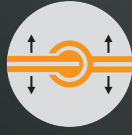

Radial disassembly, ease of service



Torque limiter with synchronous ratcheting



Maximum operating temperature



standard drop-out centre lengths available



Torque limiter with idle rotation type



High speeds



Available in accordance with API



Hardened surface



backlash-free



Complying with ATEX  
For details refer to our ATEX leaflet



Accuracy X %



non fail-safe type, separating, slipping



Certified in accordance with ABS



Consider axial displacement



Additional features compared to standard version