

SECTIONAL DIRECTIONAL
CONTROL VALVES

SDS 100



walvoil
HYDRAULIC CONTROL SYSTEMS

Simple, compact and heavy duty designed sectional valve from 1 to 12 sections for open and closed centre hydraulic systems.

- Fitted with a main pressure relief valve and a load check valve on every working section
- Available with parallel, tandem or series circuit.
- Optional carry-over port.
- A wide range of fixed setting antishock+anticavitation port valves.
- Intermediate sections for several types of circuit.
- Available manual, pneumatic, hydraulic and ON/OFF and proportional electro-hydraulic spool control kits.
- Diameter 14 mm (0.55 in) interchangeable spools.

Additional information

This catalogue shows the product in the most standard configurations.
Please contact Sales Dpt. for more detailed information or special request.

WARNING!

All specifications of this catalogue refer to the standard product at this date.
Walvoil, oriented to a continuous improvement, reserves the right to discontinue, modify or revise the specifications, without notice.

**WALVOIL IS NOT RESPONSIBLE FOR ANY DAMAGE CAUSED BY AN
INCORRECT USE OF THE PRODUCT.**

3rd edition August 2005:

This edition supercedes all prior documents.

Configuration examples	4
Working conditions	5
Performance data	6
Standard working sections	7
Working sections with internal pilot and drain lines	63
Installation and maintenance	93
Accessories	96

Configuration examples

Standard working sections

Fitted with manual, pneumatic, proportional hydraulic and ON/OFF solenoid control.

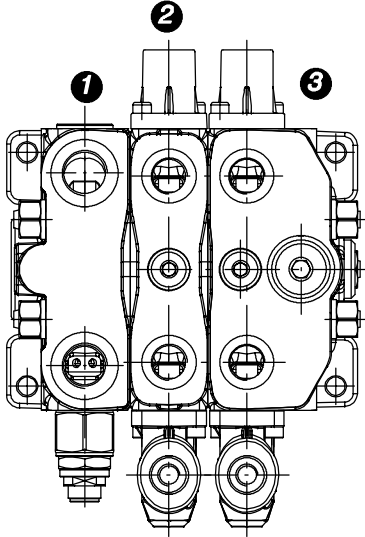

- 1) CN standard inlet section
- 2) Standard working section (type P, Q....).
- 3) Standard working section with outlet (type RP, RQ).

Working sections with internal pilot and drain lines

They need inlet section with pressure reducing valve and outlet section with backpressure valve.

They are prearranged for double side proportional electro-hydraulic control but it's possible to mount manual and mechanical control using sections with pilot through and drain

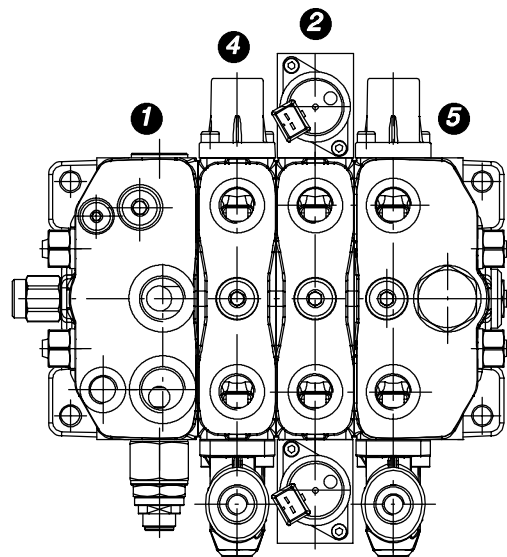
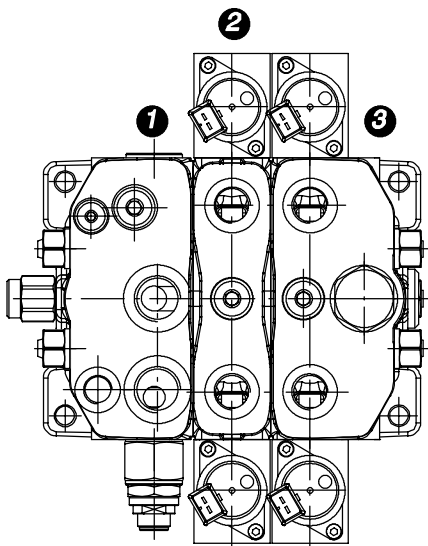

- 1) CRV inlet section with pressure reducing valve, relief valve, pilot lines on both sides, drain prearrangement, pressure reduced line prearrangement
- 2) Working sections (type PE, QE....) with double side electro-hydraulic control
- 3) Double side electro-hydraulic control working section with optional outlet (type RPE, RQE), pilot lines on both side and backpressure valve
- 4) Working section (type PA, QA....) with mechanical control and pilot through and drain.
- 5) Mechanical control working section with optional outlet (type RPA, RQA), O-ring seats for pilot through line closing, backpressure valve

Working conditions

This catalogue shows technical specifications and diagrams measured with mineral oil of 46 mm²/s – 46 cSt viscosity at 40°C temperature.

Nominal flow rating		60 l/min	
Operating pressure (max.)		315 bar	4600 psi
Back pressure (max.)	<i>on outlet port T</i>	10 bar	145 psi
Internal leakage A(B)→T	<i>Δp=100 bar - 1450 psi fluid and valve at 40 °C</i>	5 cm ³ /min	0.31 in ³ /min
Fluid		Mineral based oil	
Fluid temperature	<i>with NBR (BUNA-N) seals</i>	from -20° to 80°C	
	<i>with FPM (VITON) seals</i>	from -20° to 100°C	
Viscosity	<i>operating range</i>	from 15 to 75 mm ² /s	<i>from 15 to 75 cSt</i>
	<i>min.</i>	12 mm ² /s	12 cSt
	<i>max.</i>	400 mm ² /s	400 cSt
Max level of contamination		-/19/16 – ISO 4406	
Ambient temperature	<i>with mechanical, pneumatic and hydraulic devices</i>	from -40° to 60°C	
	<i>with electric devices</i>	from -20° to 60°C	
Tie rods tightening torque (wrench 17)		35 Nm	26 lbf ^t

NOTE - For different conditions please contact Sales Dept.

Standard thread

REFERENCE STANDARDS

		BSP	UN-UNF	NPTF
THREAD ACCORDING TO		ISO 228/1	ISO 263	ANSI B1.20.3
		BS 2779	ANSI B1.1 unified	
CAVITY ACCORDING TO	ISO	1179	11926	
	SAE		J1926	J476a
	DIN	3852-2 shape X or Y		

PORTS THREAD

MAIN PORTS	BSP	UN-UNF
Inlet P and carry-over C	G 1/2	7/8-14 (SAE 10)
Ports A and B	G 3/8	3/4-16 (SAE 8)
Outlet T	G 1/2	7/8-14 (SAE 10)
Pilot V and drain L	G 1/4	9/16-18 (SAE 6)
CONTROLS PILOT PORTS		
Pneumatics	NPTF 1/8-27	NPTF 1/8-27
Hydraulics	G 1/4	7/16-20 (SAE 4)

Performance data (pressure drop vs. flow)

Open centre

From upper inlet to upper outlet.

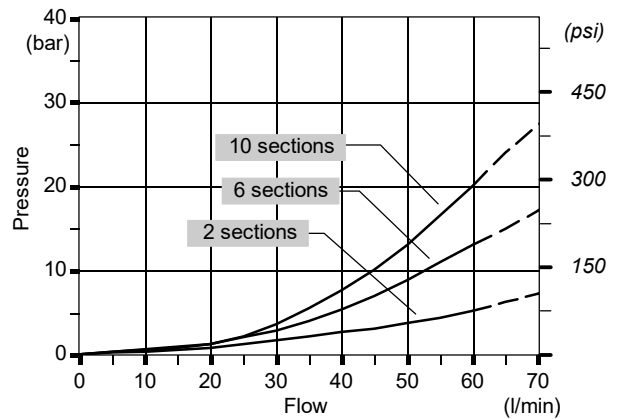
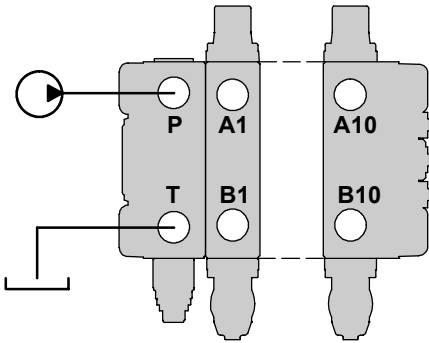

Inlet to work port

From upper inlet to A port (spool in position 1) or B port (spool in position 2).

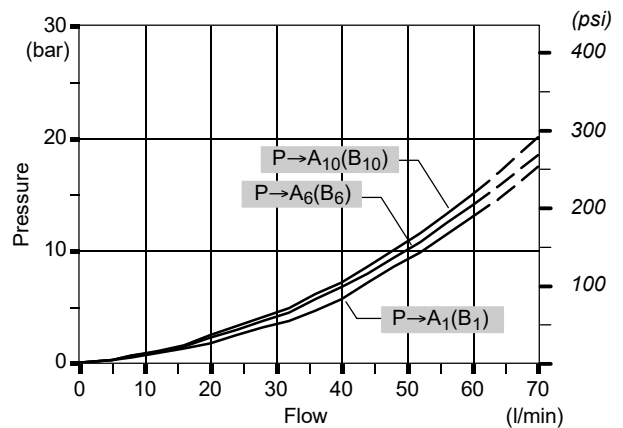
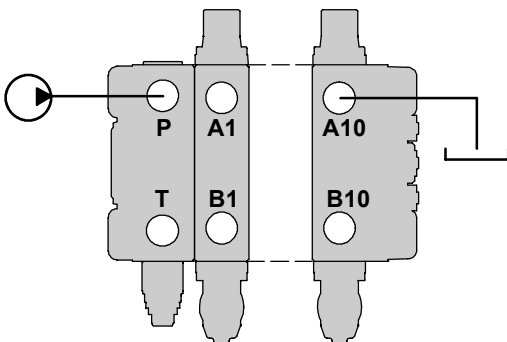

Work port to outlet

From A port (spool in position 2) or B port (spool in position 1) to side outlet.

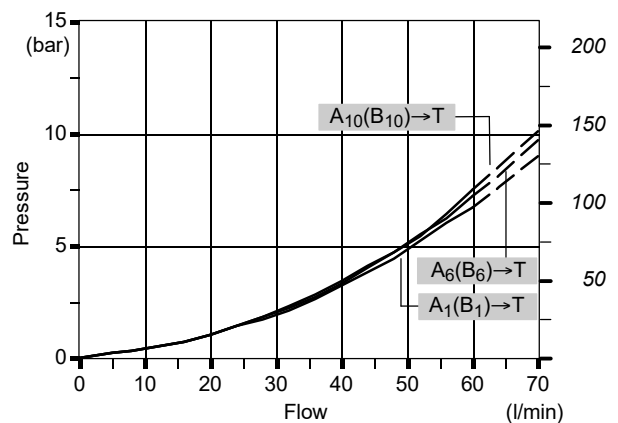
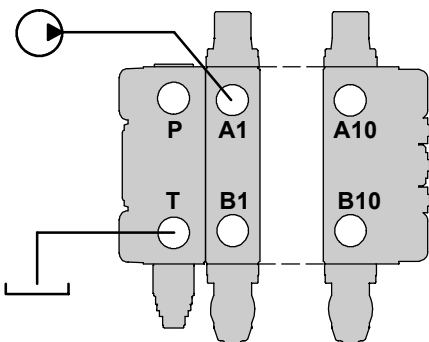

NOTA - Rilevate con cursore tipo 101.

Standard working section

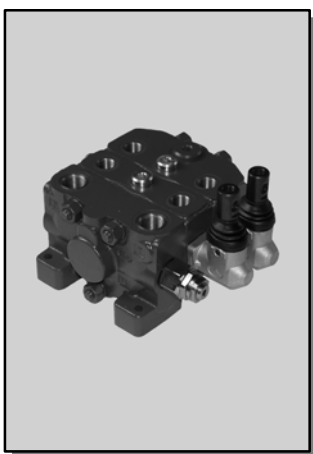

Dimensional data 8

Hydraulic circuit 9

Ordering codes 12

Inlet and outlet section

 ordering codes 14

 section body kit and hydraulic circuit 15

 inlet relief options 17

 inlet valve options 18

Working section

 ordering codes 20

 section body kit and hydraulic circuit 22

 spools 25

 “A” side spool positioners 31

 “B” side options 41

 complete controls 48

 port valves 54

Intermediate section

 with service relief valve 56

 mid return manifold section 57

Working section with optional outlet

 ordering codes 58

 section body kit and hydraulic circuit 59

 circuit configuration 61

SDS100

Dimensional data

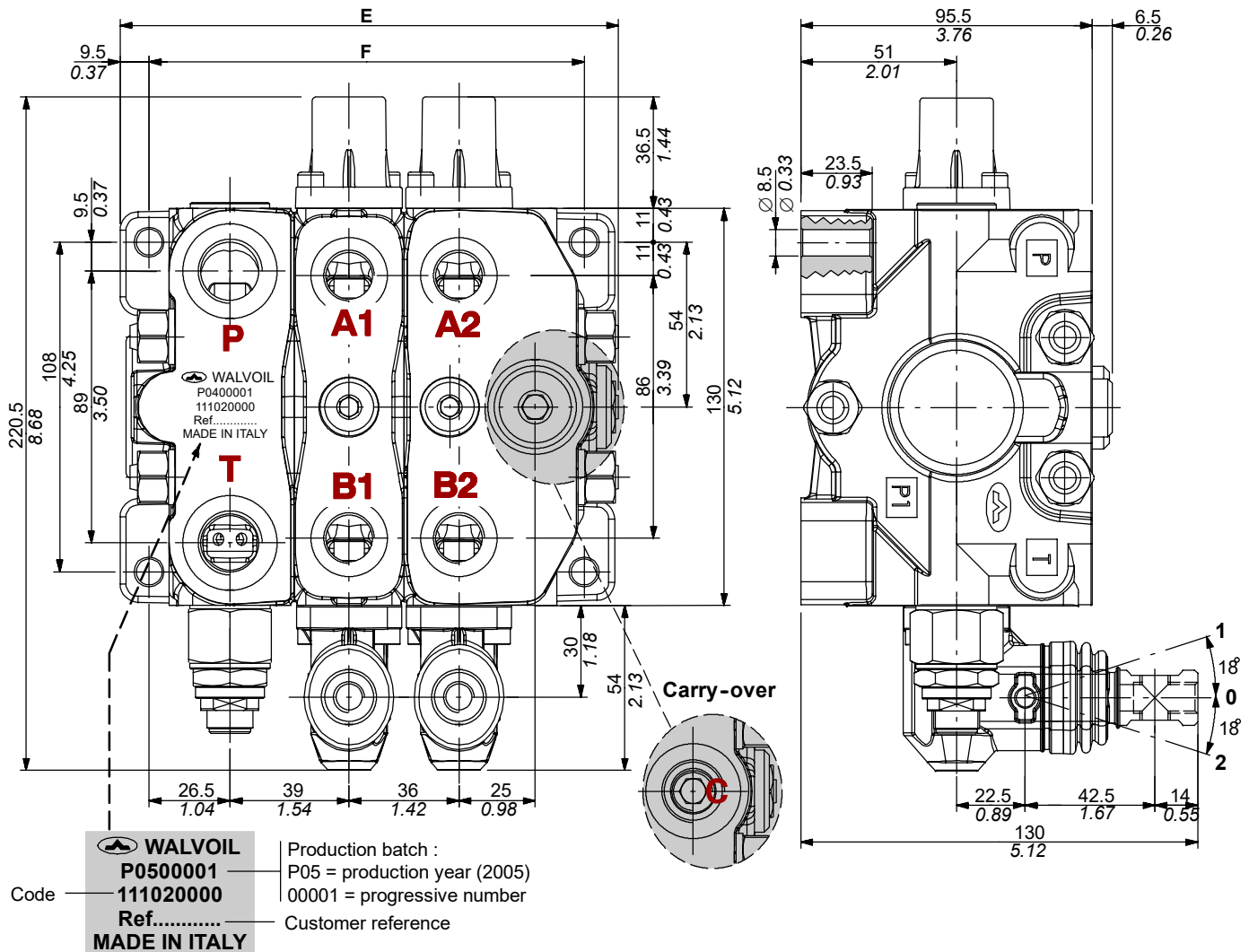

TYPE	E		F		Weight	
	mm	in	mm	in	kg	lb
SDS100/1	127.2	5.01	106.5	4.19	8.1	17.9
SDS100/2	163.2	6.43	142.5	5.61	11	24.3
SDS100/3	199.2	7.84	178.5	7.03	13.9	30.6
SDS100/4	235.2	9.26	214.5	8.44	16.8	37
SDS100/5	271.2	10.68	250.5	9.86	20.4	45

TYPE	E		F		Weight	
	mm	in	mm	in	kg	lb
SDS100/6	307.2	12.09	286.5	11.28	23.3	51.4
SDS100/7	343.2	13.51	322.5	12.70	26.2	57.8
SDS100/8	379.2	14.93	358.5	14.11	29.1	64.2
SDS100/9	415.2	16.35	394.5	15.53	32	70.5
SDS100/10	551.2	21.7	430.5	16.95	34.9	76.9

Parallel circuit

The following pictures show the directional valve with upper inlet and outlet and mechanical control.

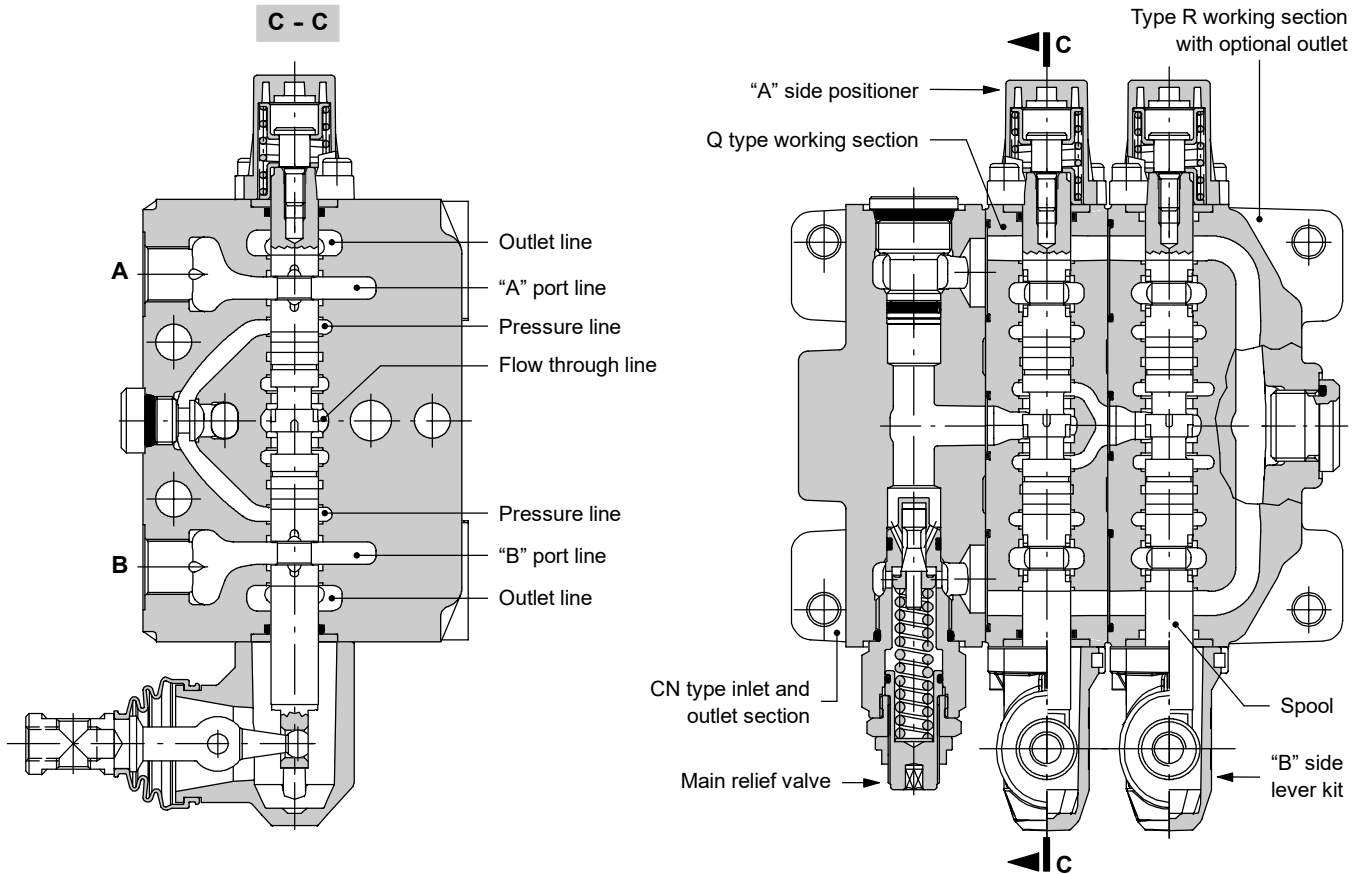

Open centre circuit

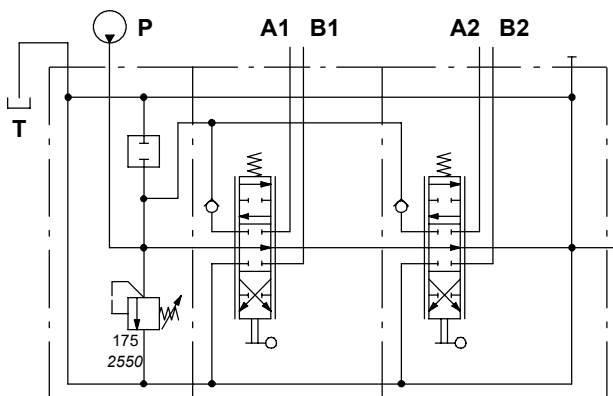

Description example:

SDS100/2/CN(TVG3-175)/Q-101-8L/RQ-101-8L-F

Closed centre circuit

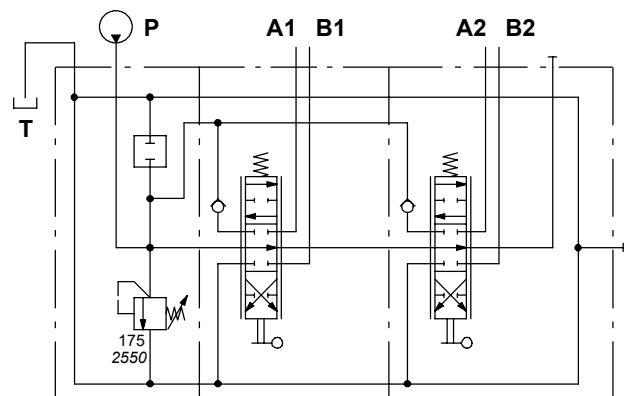

Description example:

SDS100/2/CN(TVG3-175)/Q-101-8L/RQ-101-8L-AEK

Hydraulic circuit

Tandem circuit

On standard working section

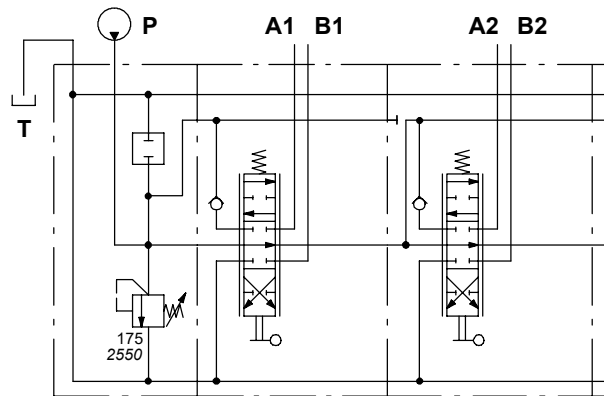

Description example:

SDS100/2/CN(TVG3-175)/Q-101-8L/SQ-101-8L/..

On working section with optional outlet

Special QR or PR section upstream the optional outlet section is required (see page 24).

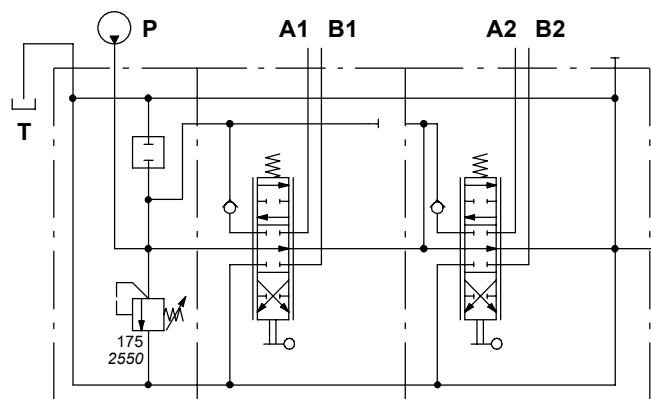

Description example:

SDS100/2/CN(TVG3-175)/QR-101-8L/RQS-101-8L-F

Series circuit

On standard working section

Obtainable with a parallel section with a series spool 1S01 or 2S01 (see page 28) and a series-parallel (tandem) section downstream.

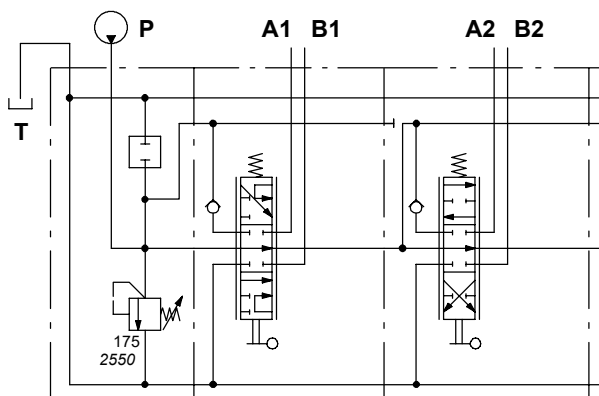

Description example:

SDS100/2/CN(TVG3-175)/Q-1S01-8L/SQ-101-8L/..

On working section with optional outlet

Obtainable with a QR or PR section (see page 24) with a series spool 1S01 or 2S01 (see page 28) and an optional outlet section with series-parallel (tandem) circuit downstream.

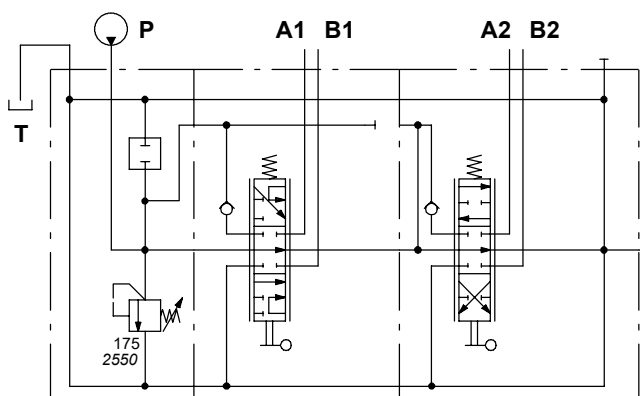

Description example:

SDS100/2/CN(TVG3-175)/QR-1S01-8L/RQS-101-8L-F

Ordering codes

Description example for standard configuration:

SDS100 / 3 / CN(TVG3-175) / Q-101-8L / EI2(TG3-125) / Q-101-8L / RQ-101-8L-F

nr. of working sections

1.

2.

3.

2.

4.

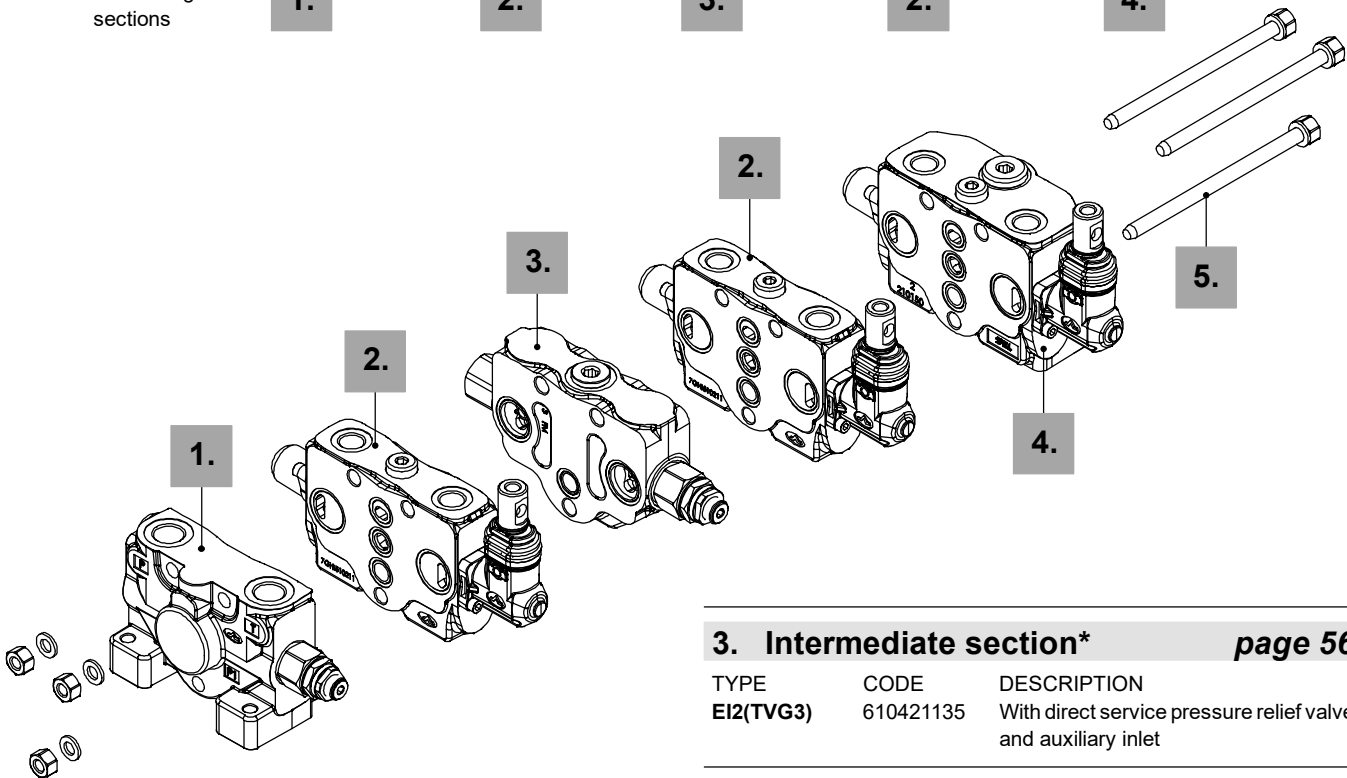

1. Complete inlet section* [page 14](#)

TYPE	CODE	DESCRIPTION
CN(TVG3-175)	610201001	Section with upper inlet and outlet and pressure relief valve
CN(SV)	610201002	Section with upper inlet and outlet and valve seat plugged

2. Complete working section* [page 20](#)

TYPE	CODE	DESCRIPTION
Q-101-8L	610151000	Parallel circuit, double acting spool with spring return and lever control
P-101-8L.UTUT	610101000	As previous with port valves prearrangement
SQ-101-8L	610121001	Tandem circuit, double acting spool with spring return and lever control
QR-101-8L	610151005	As previous to be couple with RQS or RPS sections
SP-101-8L.UTUT	610121000	Tandem circuit, double acting spool with spring return, lever control and port valves prearrangement
PR-101-8L.UTUT	610101008	As previous to be couple with RQS or RPS sections

3. Intermediate section* [page 56](#)

TYPE	CODE	DESCRIPTION
EI2(TVG3)	610421135	With direct service pressure relief valve and auxiliary inlet

4. Section with optional outlet* [page 58](#)

TYPE	CODE	DESCRIPTION
RQ-101-8L-F	610351001	Parallel circuit
RP-101-8L.UTUT-F	610301001	Parallel circuit with port valves prearrangement
RQ-101-8L-AE	610351002	Parallel circuit with carry-over
RP-101-8L.UTUT-AE	610301002	Parallel circuit with port valves prearrangement and carry-over
RQS-101-8L-F	610321002	Tandem circuit
RPS-101-8L.UTUT-F	610321001	Tandem circuit with port valves prearrangement

5. Assembling kit

CODE	DIRECTIONAL VALVE
5TIR110123	Tie rod kit for 1 section valve
5TIR110160	Tie rod kit for 2 sections valve
5TIR110195	Tie rod kit for 3 sections valve
5TIR110235	Tie rod kit for 4 sections valve
5TIR110267	Tie rod kit for 5 sections valve
5TIR110304	Tie rod kit for 6 sections valve
5TIR110340	Tie rod kit for 7 sections valve
5TIR110375	Tie rod kit for 8 sections valve
5TIR110411	Tie rod kit for 9 sections valve
5TIR110449	Tie rod kit for 10 sections valve

NOTE (*) - Items are referred to **BSP** threads.

Description example for configuration with 2 inlet section and mid return manifold:

SDS100 / 2 / CN(TVG3-175) / Q-101-8L / CS1 / Q-101-8L / BN(TVG3-175)

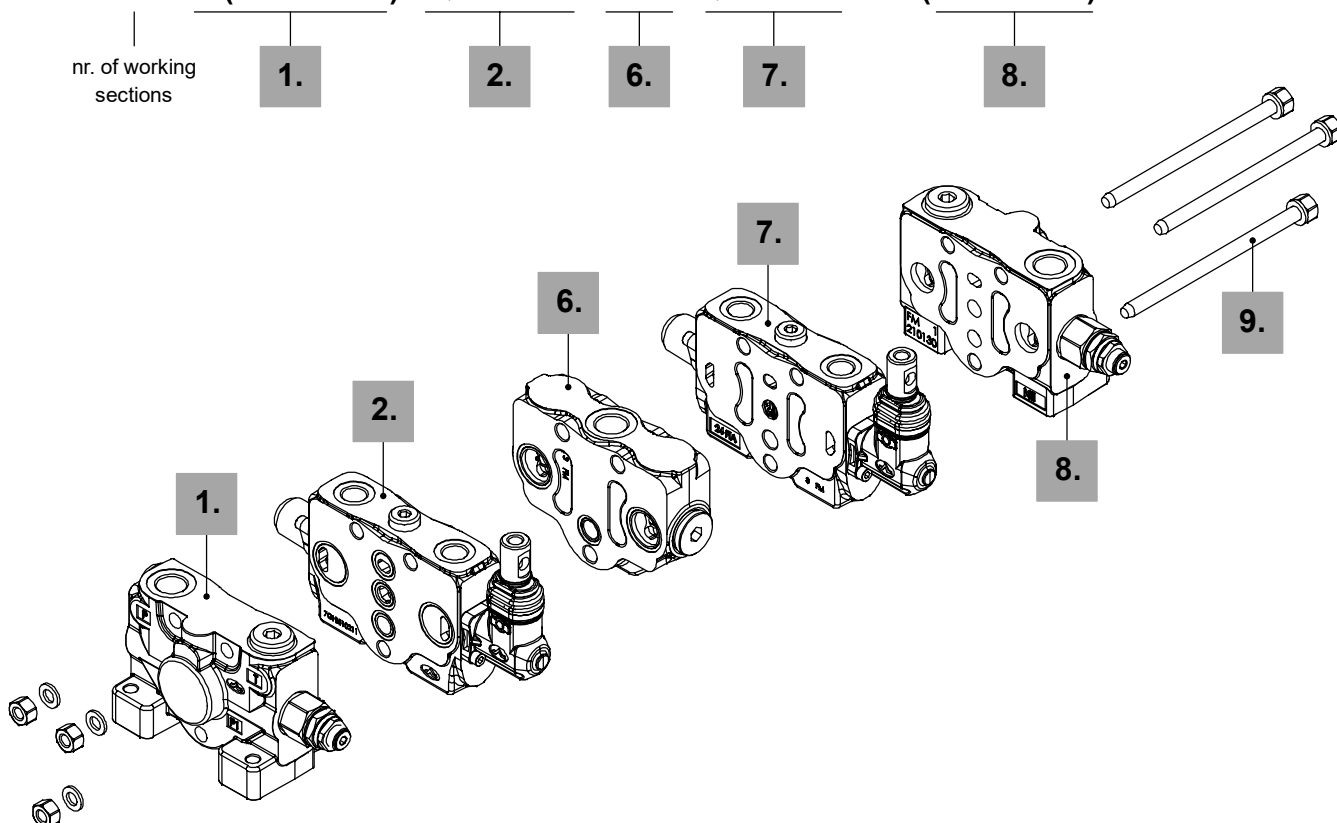

6. Return manifold* pag. 57

TYPE	CODE	DESCRIPTION
CS1	610400010	Mid return manifold

7. Complete right inlet working section*

TYPE	CODE	DESCRIPTION
ED-Q-101-8L	610151004	Parallel circuit, double acting spool with spring return and lever control
ED-P-101-8L.UTUT	610101007	As previous with port valves prearrangement
ED-SQ-101-8L	610121008	Tandem circuit, double acting spool with spring return and lever control
ED-SP-101-8L.UTUT	610121009	As previous with port valves prearrangement

8. Complete right inlet section*

TYPE	CODE	DESCRIPTION
BN(TVG3-175)	610201006	Section with upper inlet and outlet and pressure relief valve
BN(SV)	610201007	Section with upper inlet and outlet and valve seat plugged

9. Assembling kit with for valve with CS1

CODE	DIRECTIONAL VALVE
5TIR110215	Tie rod kit for 2 section valve + manifold
5TIR110252	Tie rod kit for 3 section valve + manifold
5TIR110289	Tie rod kit for 4 section valve + manifold
5TIR110323	Tie rod kit for 5 section valve + manifold
5TIR110359	Tie rod kit for 6 section valve + manifold
5TIR110397	Tie rod kit for 7 section valve + manifold
5TIR110431	Tie rod kit for 8 section valve + manifold
5TIR110467	Tie rod kit for 9 section valve + manifold
5TIR110503	Tie rod kit for 10 section valve + manifold

NOTE (*) - Items are referred to **BSP** thread; sections and covers for right inlet are different from the standard (see ref. 1 e 2) because of different components assembling

Inlet and outlet section

Description example:

FE SDS100 / CN (TVG3 - 175) ELT-12VDC *

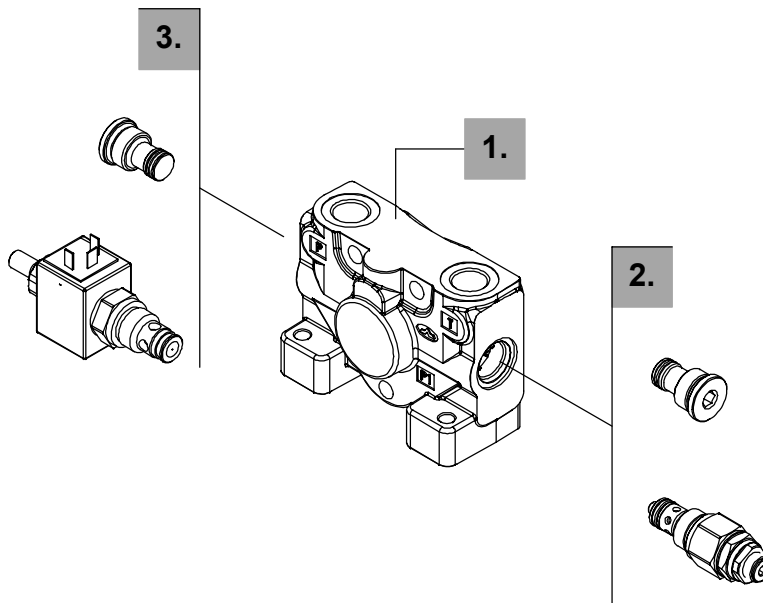
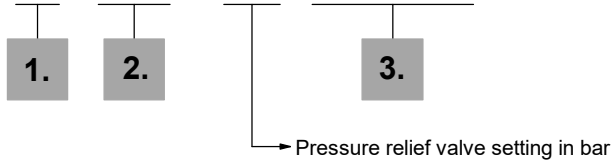

1. Section body * page 15

TYPE	CODE	DESCRIPTION
CN	3FIA107300	Standard configuration
CNM	3FIA107301	With pressure gauge prearrangement
CNL	3FIA107304	With side inlet

2. Inlet relief options page 17

Standard setting is referred to 10 l/min flow.

TYPE	CODE	DESCRIPTION
<u>VMD100/1: direct pressure relief valve type T (standard)</u>		
(TVG2-80)	X196121081	Range 63 to 100 bar / 900 to 1450 psi standard setting 80 bar / 1160 psi
(TVG3-175)	X196121176	Range 100 to 200 bar / 1450 to 2900 psi standard setting 175 bar / 2550 psi
(TVG4-220)	X196121220	Range 200 to 300 bar / 2900 to 4350 psi standard setting 220 bar / 3200 psi

SV XTAP526360 Pressure relief valve blanking plug

3. Inlet valve options page 18

TYPE	CODE	DESCRIPTION
ELN	5CAR407330	12 VDC solenoid operated unloader valve
ELT	5CAR407331	As previous 24 VDC
	5CAR407320	12 VDC solenoid operated unloader valve with "push and twist" emergency push-button
SV	5CAR407325	As previous 24 VDC
	XTAP526360	Valve blanking plug: in valve description the word SV must be omitted because standard

NOTE (*) - Items are referred to **BSP** thread.

Section body and hydraulic circuit

CN standard configuration

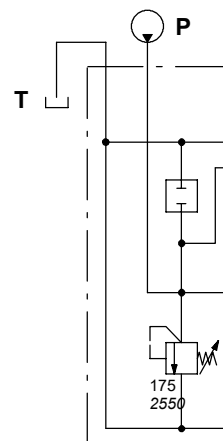
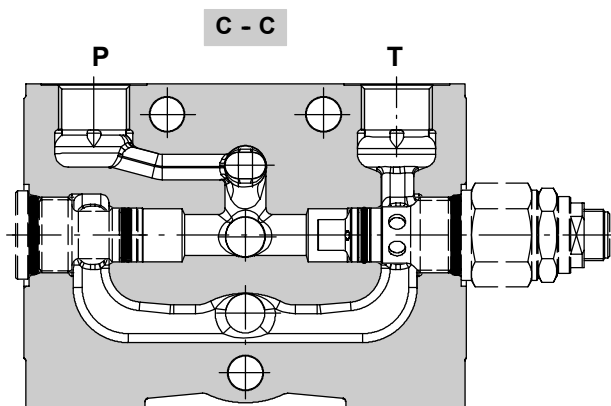
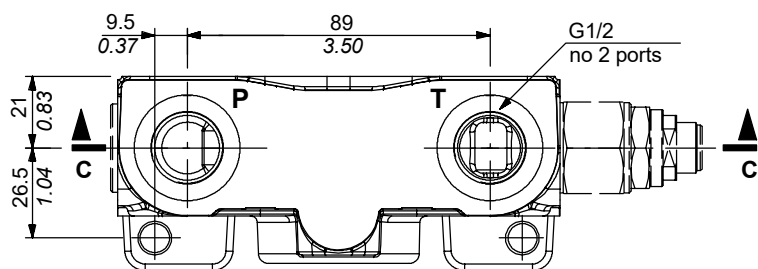
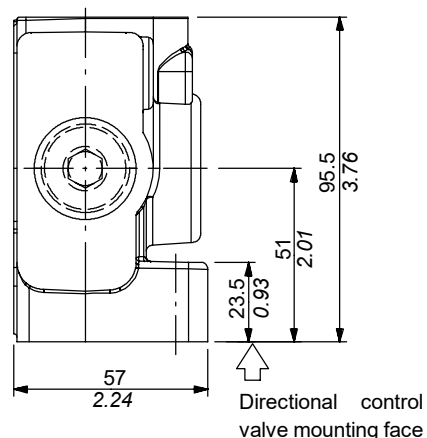
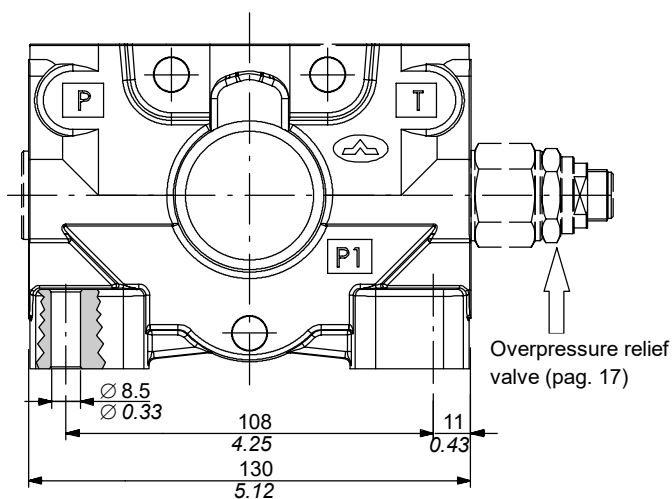

Description example:
CN(TVG3-175)

Inlet and outlet section

Section body and hydraulic circuit

CNM configuration: with pressure gauge prearrangement

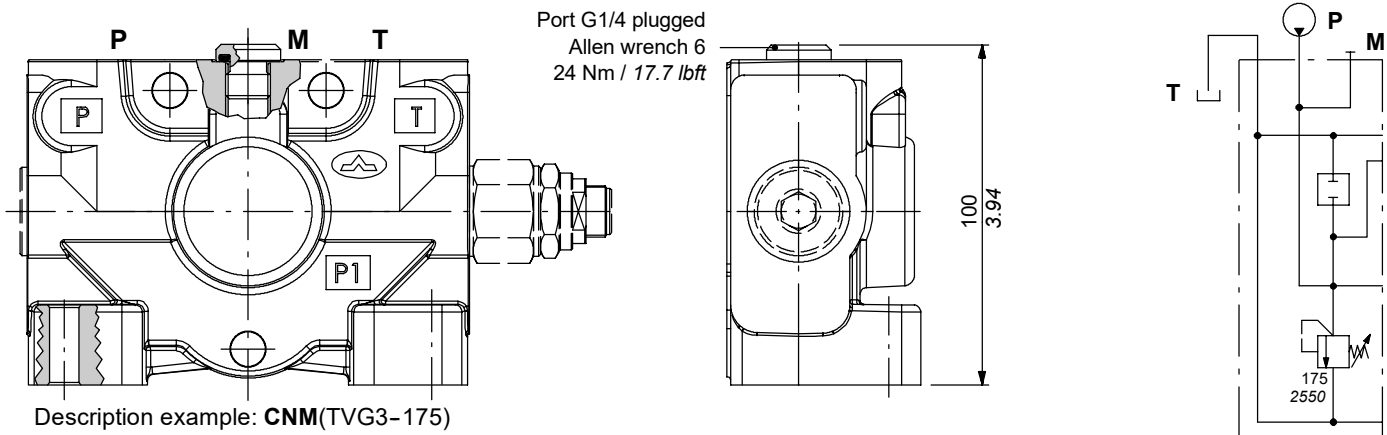

CNL configuration: with side inlet arrangement

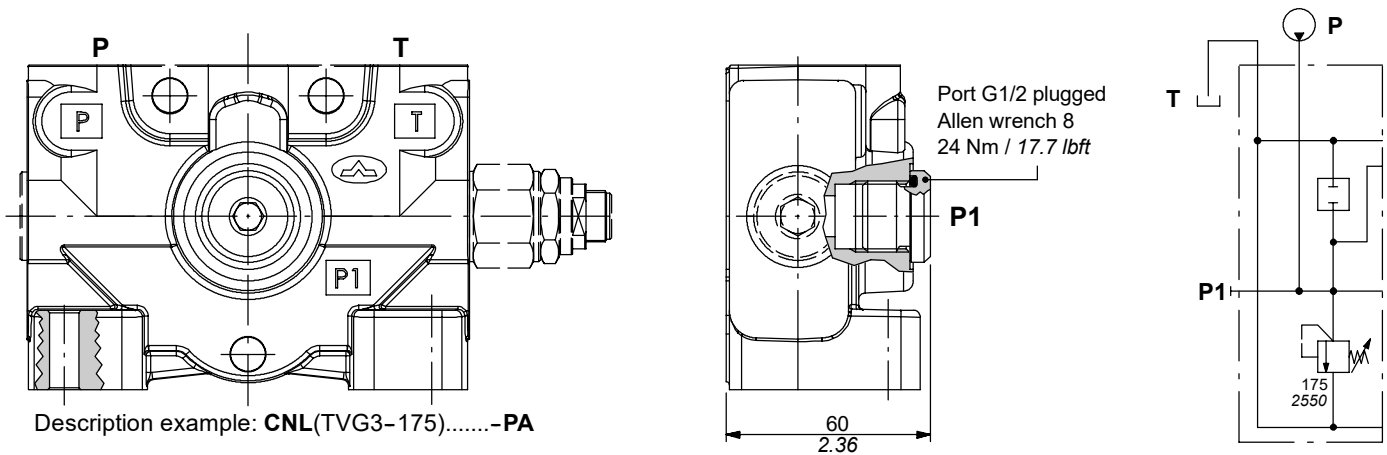

Inlet relief options

Direct pressure relief valve

VMD100 (TV G 3 - 175)

- Pressure setting in bar (for standard value see page 8)
- Adjustable spring type (2, 3, 4).
- Adjustment type (G, Z)

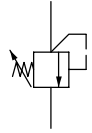

Adjustment type

G: with screw

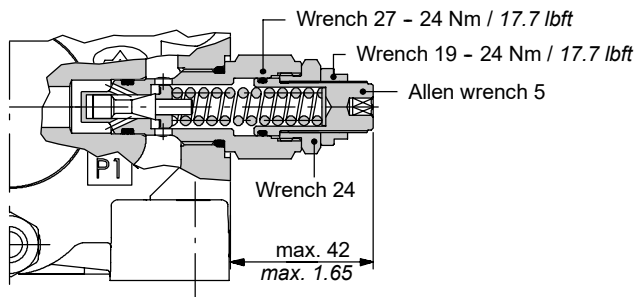

Z: with tamper proof cap

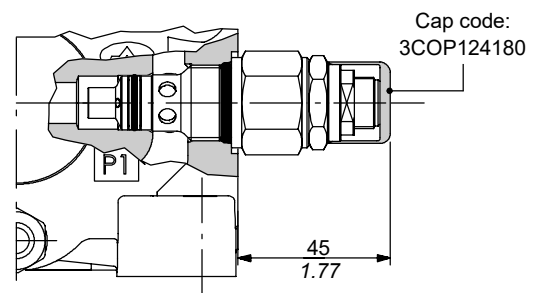

Performance data

Spring nr. 2 (green band)

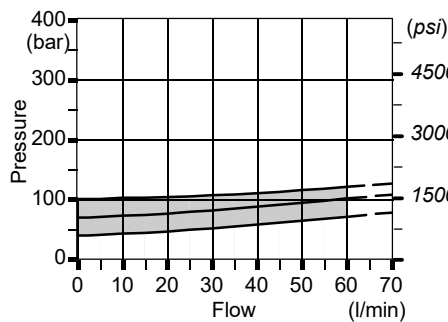

Spring nr. 3 (blue band)

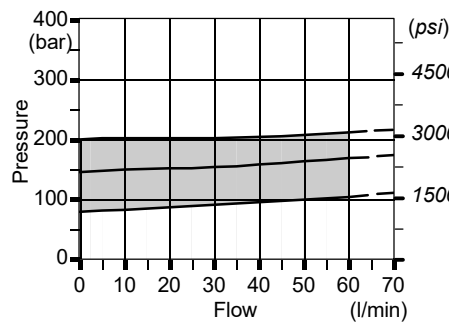

Spring nr. 4 (red band)

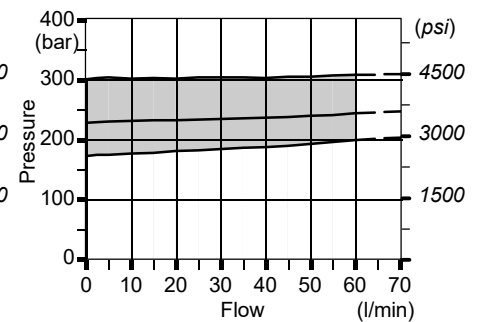

SV: relief valve blanking plug

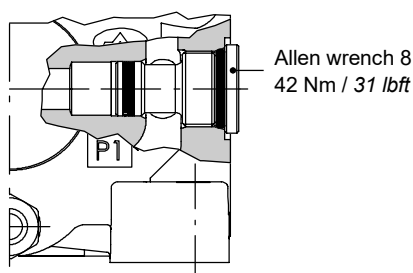

Time response

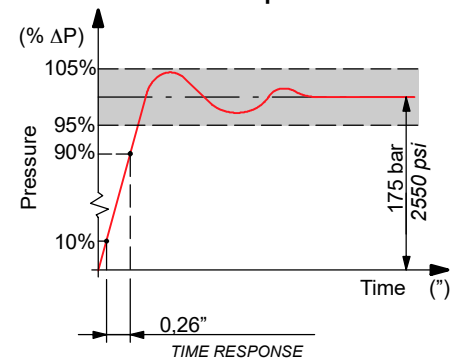

Inlet valve options

Solenoid operated unloader valves

ELN configuration

Without emergency push-button

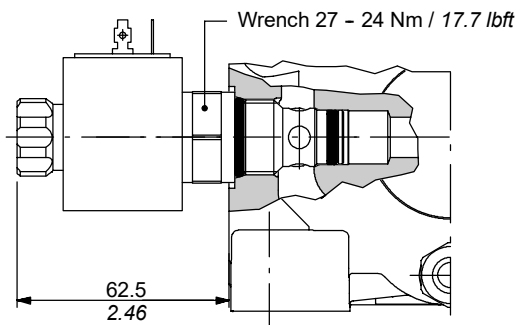

ELT configuration

Emergency with push button and spring return; for detent position turn the button after press it.

WARNING : the manual override option is intended for emergency use, not for continuous duty operation.

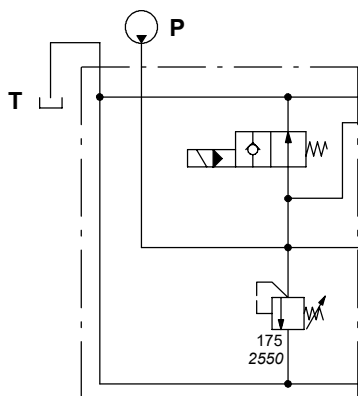
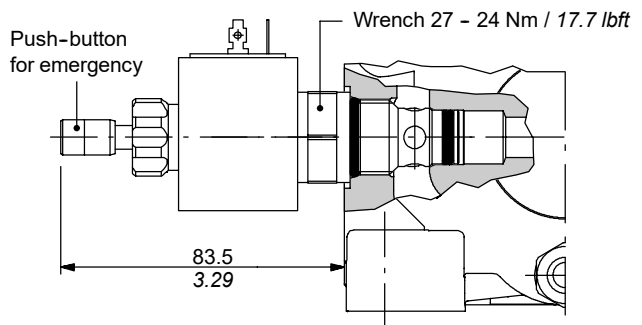

Description example:
CN(TVG3-175)ELN-12VDC

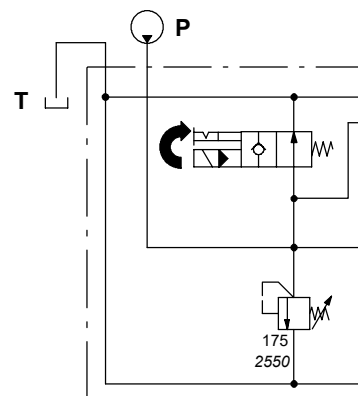

Description example:
CN(TVG3-175)ELT-12VDC

Pressure drop curve

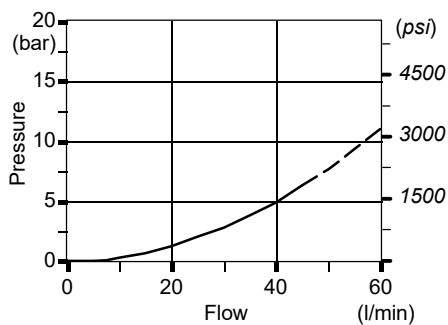

Operating features

VALVE

Internal leakage (excited position) :
75 cm³/min at 100 bar / 4.45 in³/min at 1450 psi

COIL

Depending on model: see following features

SDS100

Working section

Description example:

EL SDS100 / Q - 101 - 8 L *

1. 2. 3. 4.

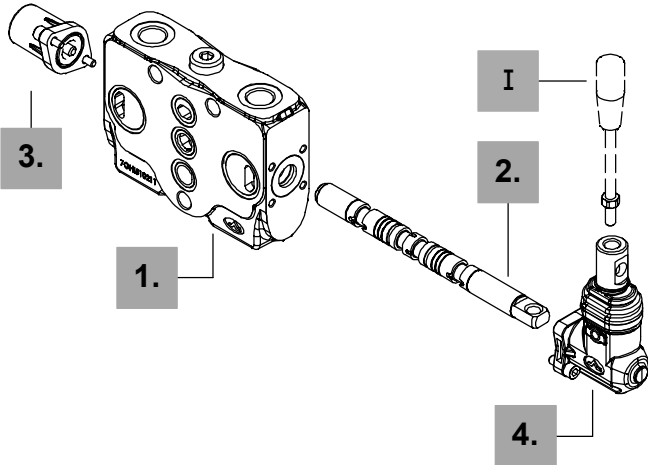

Port valve setting in bar ←
EL SDS100 / P - 101 - 8 L . U100 U100 *

1. 6.

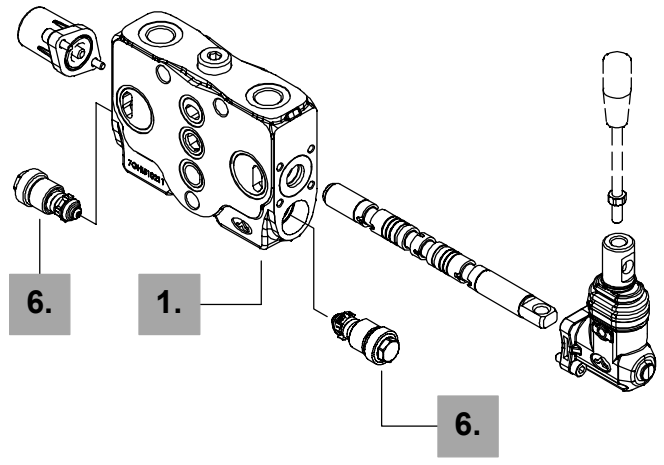

EL SDS100 / Q - I112 - 8IM

5.

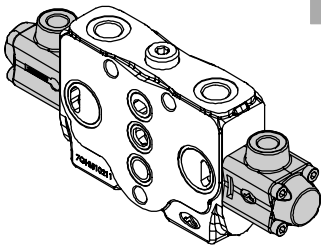

8IM

EL SDS100 / Q - S112 - 8ES3-12VDC

5.

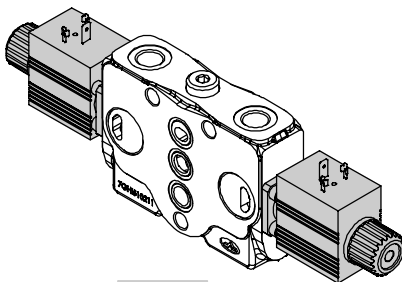

8ES3

1. Working sections kit* page 22

Include body, seals, rings and load check valve.

TYPE	CODE	DESCRIPTION
Q	5EL1073010	Parallel circuit without port valves prearrangement
P	5EL1073000	Parallel circuit with port valves prearrangement
SQ	5EL3073010	Tandem circuit without port valves prearrangement
QR	5EL1573090	As previous for section type RQS or RPS
SP	5EL3073000	Tandem circuit with port valves prearrangement
PR	5EL1573095	As previous for section type RQS or RPS
<u>Sections kit for special spools</u>		
Q5	5EL1073210	Parallel circuit and floating prearrangement: for spool type 501
P5	5EL1073200	As previous with port valves prearrangement: for spool type 501

NOTE (*) - Items are referred to **BSP** thread.

2. Spools page 25

If not specified otherwise, the spool are from 20 to 40 l/min flow

TYPE	CODE	DESCRIPTION
102	3CU6210110	Double acting, 3 positions, with A and B closed in neutral position; for flow up to 20 l/min
101	3CU6210100	As previous, from 20 to 40 l/min flow
109	3CU6210202	As previous, from 40 to 60 l/min flow
201	3CU6225130	Double acting, 3 positions, with A and B open to tank in neutral position
2H01	3CU6225100	Double acting, 3 positions, with A and B partially open to tank in neutral position
1S02	3CU6212100	Double acting, 3 positions, with A and B closed in neutral position, for series circuit
2S01	3CU6226130	Double acting, 3 positions, with A and B open to tank in neutral position, for series circuit
301	3CU6231100	Single acting in A, 3 positions, B plugged: needs G3/8 plug
401	3CU6235100	Single acting in B, 3 positions, A plugged: needs G3/8 plug

Specials spools for standard positioners kit page 29

801	3CU6242100	Double acting, 3 positions, regenerative in 2 nd positions with spool out
------------	------------	--

Specials spools for particular positioners kit pag. 30

501	3CU6242100	Double acting, 4 positions, floating in 4 th positions with spool in
------------	------------	---

3. “A” side spool positioners page 31

TYPE	CODE	DESCRIPTION
7FTN	5V07407010	With friction and neutral position sensor
8	5V08107000	With spring return in neutral position
8D	5V08107200	As type 8 and pin with M6 female thread for dual control
8F2	5V08107100	With spring return in neutral position and adjustable flow limiter
8TL	5V08107310	As type 8 and pin control for flexible cable operation
9B	5V09207000	With detent in position 1 and spring return in neutral position
10B	5V10207000	With detent in position 2 and spring return in neutral position
11B	5V11207000	With detent in position 1 and 2, spring return in neutral position
8K	5V08707112	As type 8 with 12 VDC spool solenoid lock device
	5V08707124	As type 8 with 24 VDC spool solenoid lock device
8RM2	5V08107590	With spring return in neutral position and 12VDC electromagnetic detent in pos. 2
	5V08107591	As previous 24VDC
8MG3(NO)	5V08107660	With spring return in neutral position and operation with microswitch in pos. 1 and 2
8PP	5V08107700	Proportional pneumatic kit
8EP3	5V08107735	ON/OFF 12 VDC electro-pneumatic kit
	5V08107740	ON/OFF 24 VDC electro-pneumatic kit

Particular positioners kit for special spools page 39

TYPE	CODE	DESCRIPTION
13	5V13307000	4 positions with spring return in neutral, detent in 4 th position: for spool type 501
13F	5V13507000	4 positions with spring return in neutral: for spool type 501

NOTE (*) – Items are referred to **BSP** thread.

4. “B” side options page 41

TYPE	CODE	DESCRIPTION
L	5LEV107000	Standard lever box
LF1	5LEV107100	Lever box with adjustable flow limiter in pos. 1
LB3	5LEV307000	Steel lever box, heavy duty type
SLP	5COP107010	Without lever box, with dust-proof plate
SLC	5COP207000	Without lever box, with endcap.
LCA1-4	5CLO207010	Joystick lever for 2 sections operation: configurations type 1 and 4
LCA2-3	5CLO207011	Joystick lever for 2 sections operation: configurations type 1 and 4
TK	5COP307100	Type SLP with solenoid spool lock device, needs special spools : see page 46

5. Complete controls page 48

They need particular sections or spools, please see the related page.

TYPE	CODE	DESCRIPTION
8ES	--	ON/OFF electric control kit: available single or double action operation
8IM	5IDR207300*	Proportional hydraulic control
13IM	5IDR207350*	4 positions proportional hydraulic control

6. Port valves page 54

TYPE	CODE	DESCRIPTION
C	5KIT410000	Anticavitation valve
UT	XTAP522441	Port valve blanking plug
<u>Fixed setting antishock with prefill valve</u>		
U025	5KIT330025	Setting 25 bar / 360 psi
U030	5KIT330030	Setting 30 bar / 430 psi
U040	5KIT330040	Setting 40 bar / 580 psi
U050	5KIT330050	Setting 50 bar / 725 psi
U063	5KIT330063	Setting 63 bar / 900 psi
U080	5KIT330080	Setting 80 bar / 1150 psi
U100	5KIT330100	Setting 100 bar / 1450 psi
U110	5KIT330110	Setting 110 bar / 1600 psi
U125	5KIT330125	Setting 125 bar / 1800 psi
U140	5KIT330140	Setting 140 bar / 2050 psi
U150	5KIT330150	Setting 150 bar / 2180 psi
U160	5KIT330160	Setting 160 bar / 2300 psi
U175	5KIT330175	Setting 175 bar / 2550 psi
U190	5KIT330190	Setting 190 bar / 2750 psi
U200	5KIT330200	Setting 203 bar / 2900 psi
U210	5KIT330210	Setting 210 bar / 3050 psi
U220	5KIT330220	Setting 220 bar / 3200 psi
U230	5KIT330230	Setting 230 bar / 3350 psi
U240	5KIT330240	Setting 240 bar / 3500 psi
U250	5KIT330250	Setting 250 bar / 3600 psi
U260	5KIT330260	Setting 260 bar / 3750 psi
U270	5KIT330270	Setting 270 bar / 3900 psi
U280	5KIT330280	Setting 280 bar / 4050 psi
U290	5KIT330290	Setting 290 bar / 4200 psi
U300	5KIT330300	Setting 300 bar / 4350 psi
U310	5KIT330310	Setting 310 bar / 4500 psi
U320	5KIT330320	Setting 320 bar / 4650 psi
U340	5KIT330340	Setting 340 bar / 4950 psi

Setting is referred to 10 l/min flow.

I Optional hand levers

TYPE	CODE	DESCRIPTION
AL01/M10x150	170012015	For L lever box: H= 150 mm / 5.91 in
AL08/M12x150	170013115	For joystick LCB: H = 150 mm / 5.91 in

Working section

Section kit and hydraulic circuit

Parallel or tandem circuits are available: for series circuit see page 10.

All sections can be fitted with or without port valves prearrangement.

Parallel circuit

Section type Q without port valves prearrangement

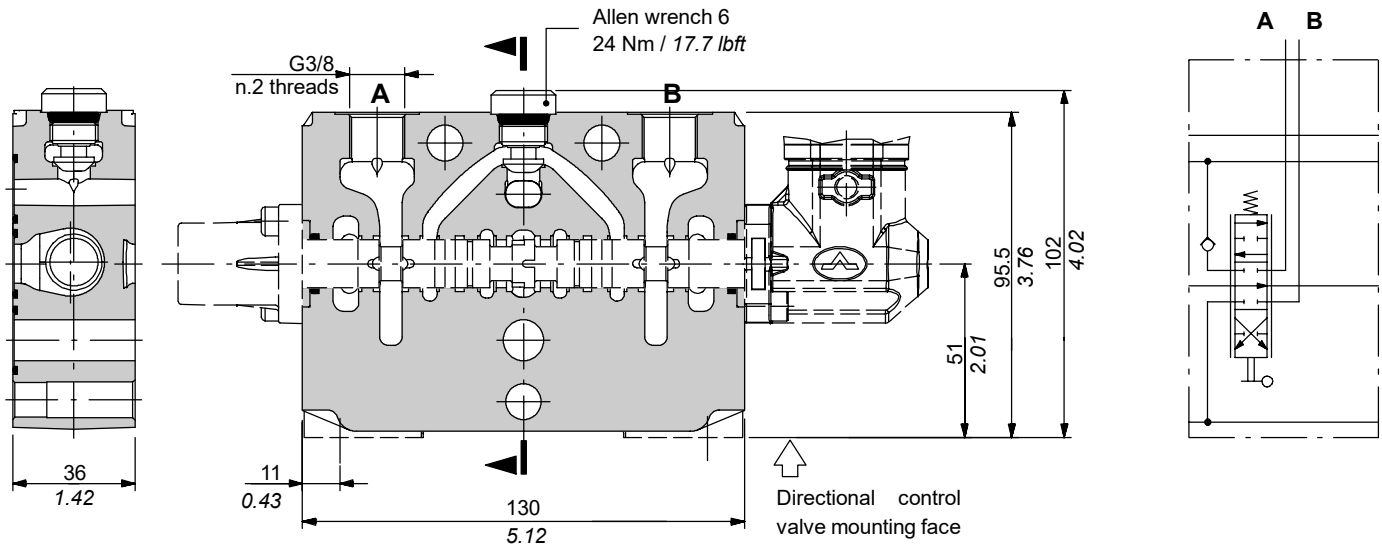

Section type P with port valves prearrangement

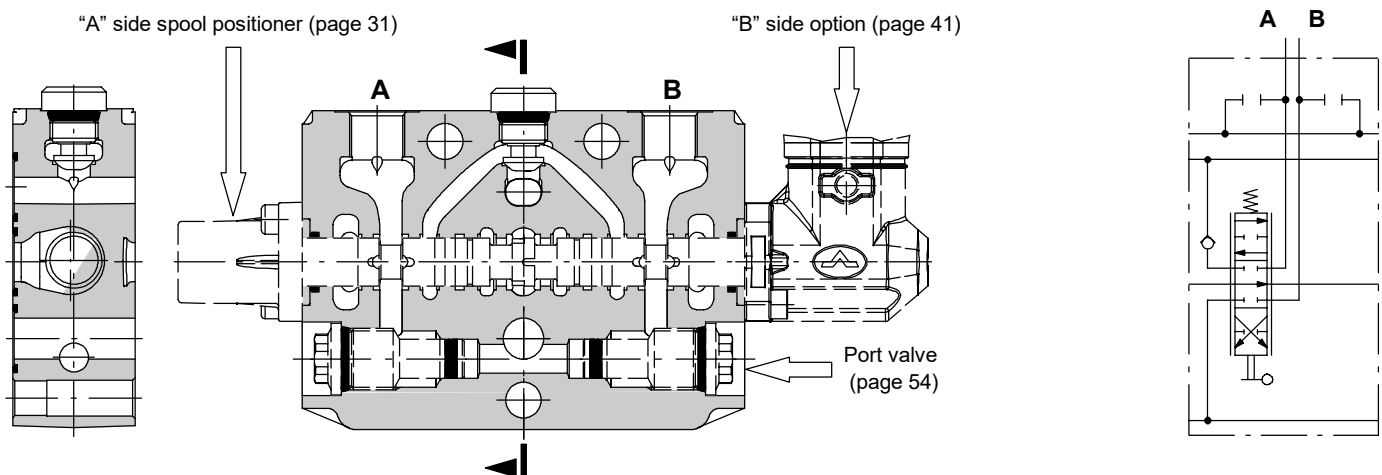

Section kit and hydraulic circuit

Tandem circuit

Dimensions are the same of parallel circuit section.

Section type SQ without port valves prearrangement

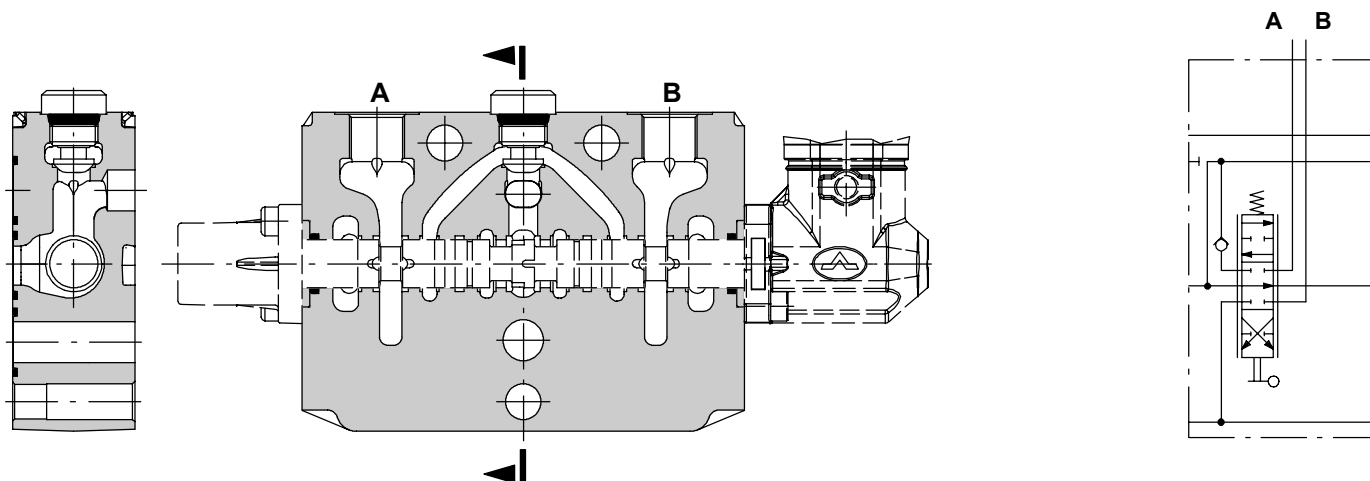

Section type SP with port valves prearrangement

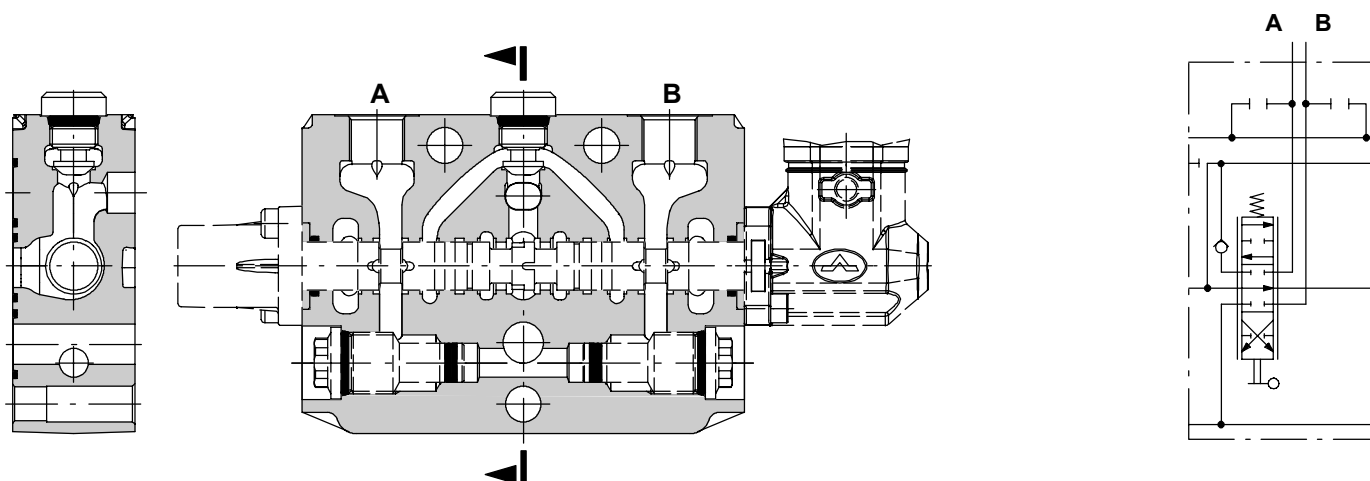

Working section

Section kit and hydraulic circuit

Special circuit

Used to get series and tandem circuits with RQS or SQS optional outlet sections (see pages 10 and 60); dimensions are the same as parallel section.

Section type QR without port valves prearrangement

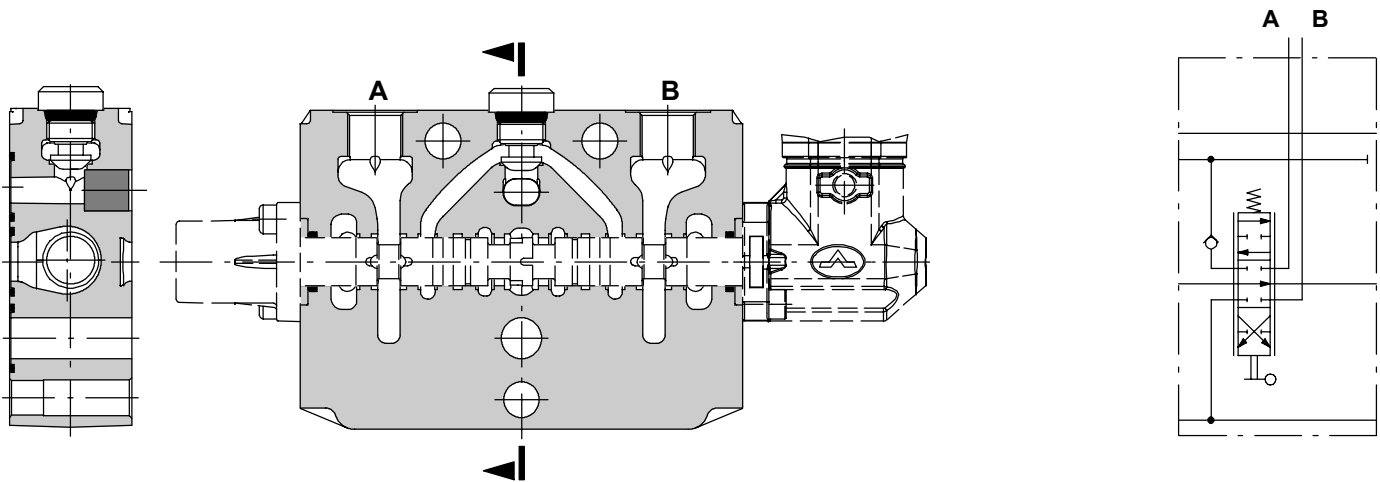

Section type PR with port valves prearrangement

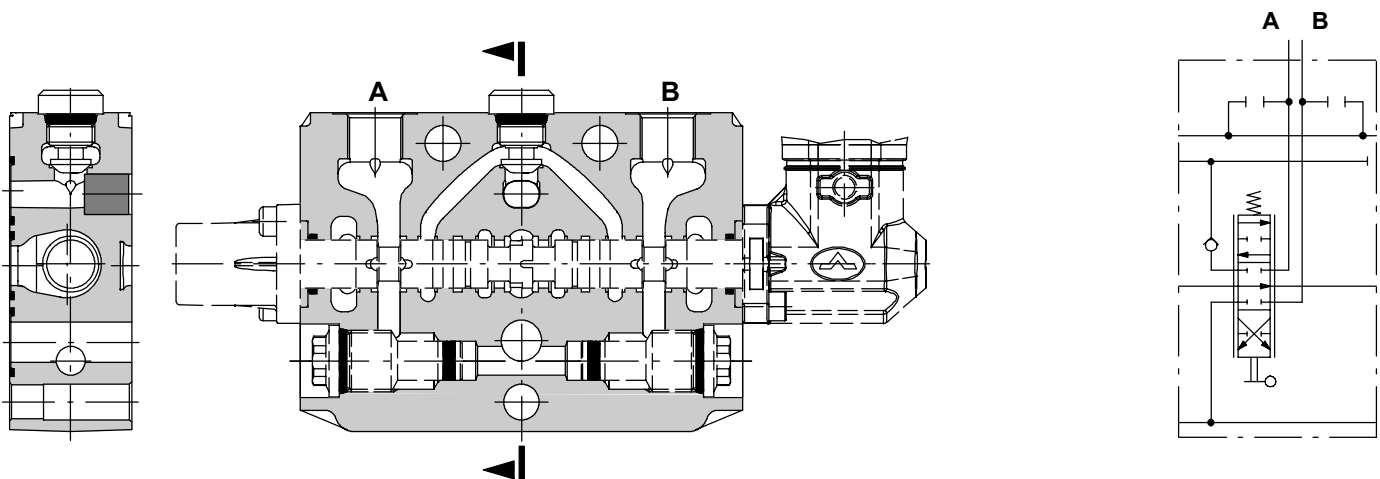

Type 101

From 20 to 40 l/min flow.

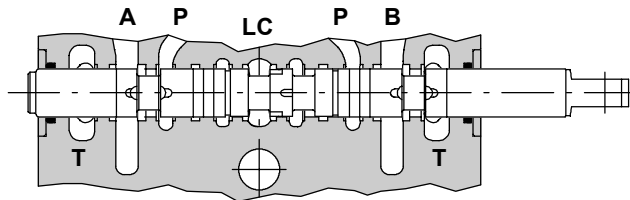

P → A B → T

▶ stroke + 6.5 mm
+ 0.26 in

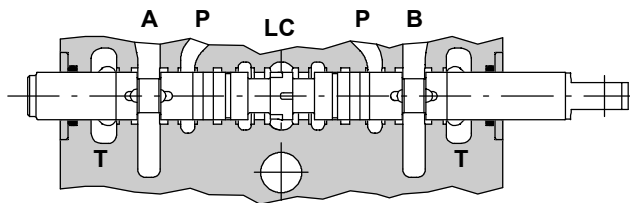
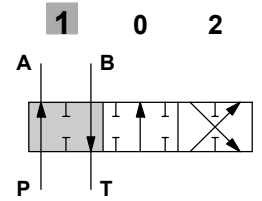

P-A-B-T closed, with flow through line (LC) open

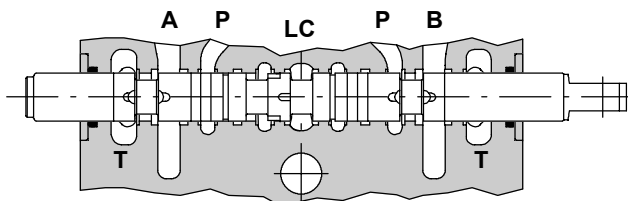
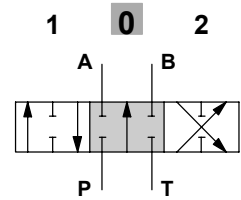

P → B A → T

◀ stroke - 6.5 mm
- 0.26 in

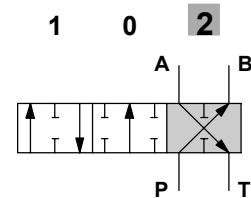

Performance data

Spool metering P → A(B)

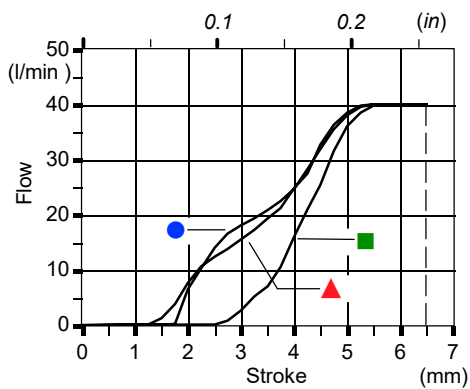

Q_{in} = 40 l/min

- P_(on ports) = 63 bar / 900 psi
- ▲ P_(on ports) = 100 bar / 1450 psi
- P_(on ports) = 250 bar / 2900 psi

Spool metering A(B) → T

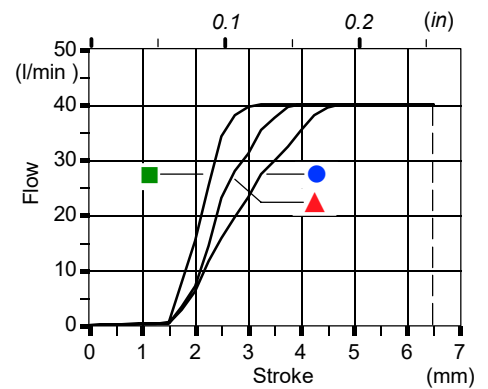

Spools

Type 102

Up to 20 l/min flow.

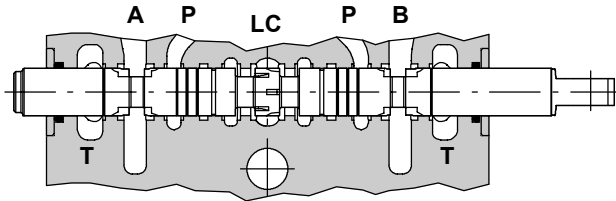

+ 6.5 mm / + 0.26 in
 (1) ▶
 ◀ ▶ (0)
 ◀ (2)
 - 6.5 mm / - 0.26 in

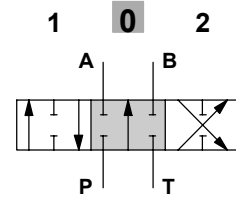

P-A-B-T closed, with flow through line (LC) open

Performance data

Spool metering P→A(B)

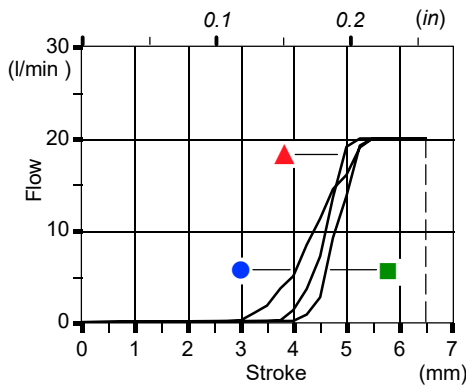

Spool metering A(B)→T

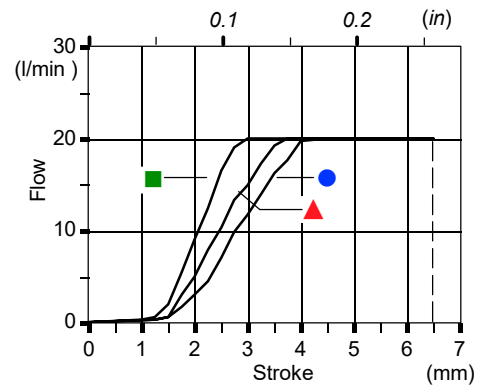

Q_{in} = 20 l/min

- P_(on ports) = 63 bar / 900 psi
- ▲ P_(on ports) = 100 bar / 1450 psi
- P_(on ports) = 250 bar / 2900 psi

Type 109

From 40 to 60 l/min flow.

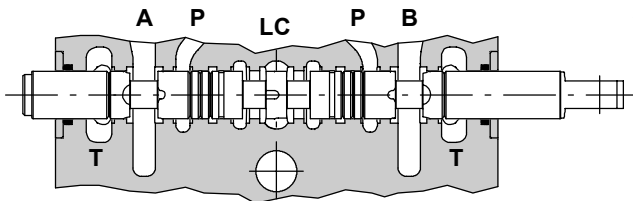

+ 6.5 mm / + 0.26 in
 (1) ▶
 ◀ ▶ (0)
 ◀ (2)
 - 6.5 mm / - 0.26 in

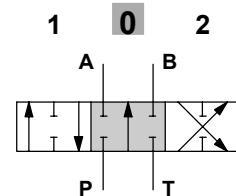

P-A-B-T closed, with flow through line (LC) open

Performance data

Spool metering P→A(B)

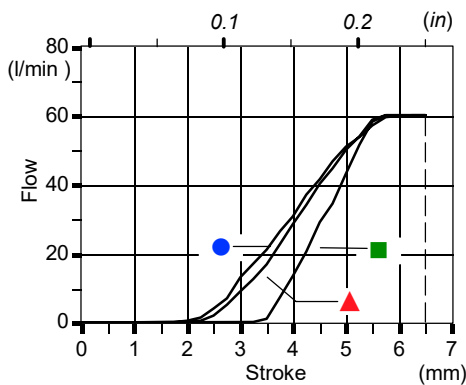

Spool metering A(B)→T

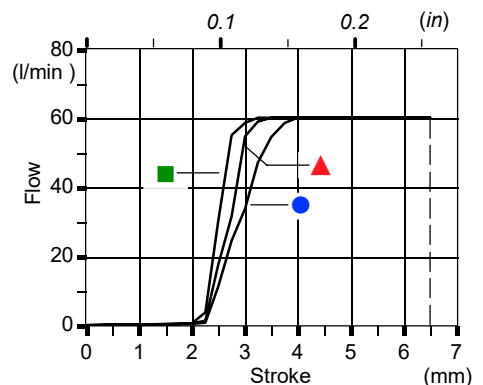

Q_{in} = 60 l/min

- P_(on ports) = 63 bar / 900 psi
- ▲ P_(on ports) = 100 bar / 1450 psi
- P_(on ports) = 250 bar / 2900 psi

Type 201

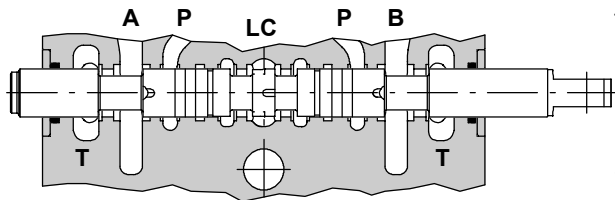

+ 6.5 mm / + 0.26 in
 (1) ▶
 ◀▶ (0)
 ◀ (2)
 - 6.5 mm / - 0.26 in

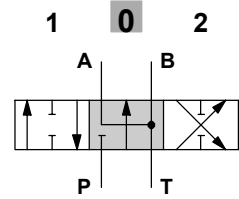

P closed, A-B to tank, with flow through line (LC) open

Type 301

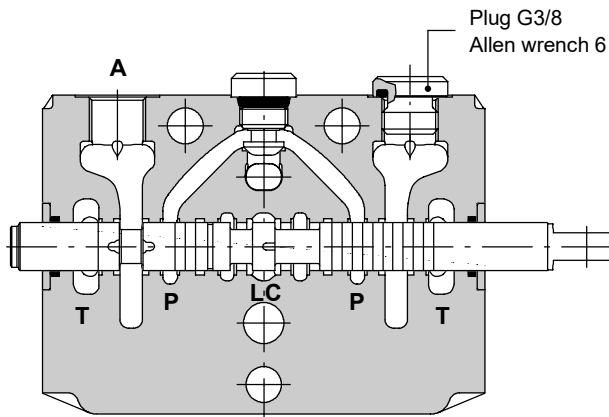

+ 6.5 mm / + 0.26 in
 (1) ▶
 ◀▶ (0)
 ◀ (2)
 - 6.5 mm / - 0.26 in

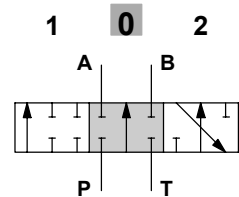

P-A-B closed, with flow through line (LC) open

Type 401

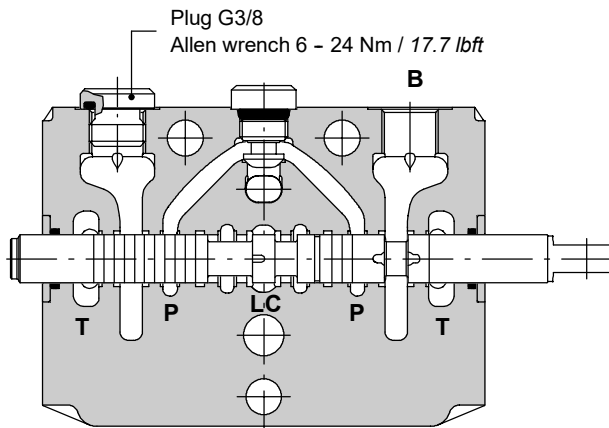

+ 6.5 mm / + 0.26 in
 (1) ▶
 ◀▶ (0)
 ◀ (2)
 - 6.5 mm / - 0.26 in

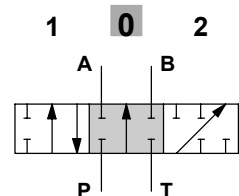

P-A-B closed, with flow through line (LC) open

Type 1S02

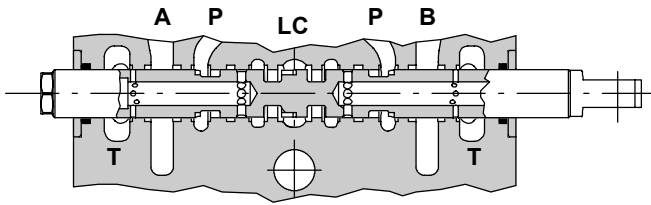

+ 6.5 mm / + 0.26 in
 (1) ▶
 ◀▶ (0)
 ◀ (2)
 - 6.5 mm / - 0.26 in

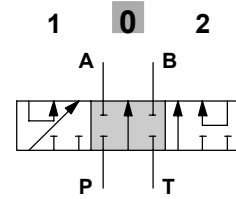

P-A-B-T closed, with flow through line (LC) open

Performance data

Spool metering

$Q_{in} = 40 \text{ l/min} / P_{(on ports)} = 100 \text{ bar} - 1450 \text{ psi}$

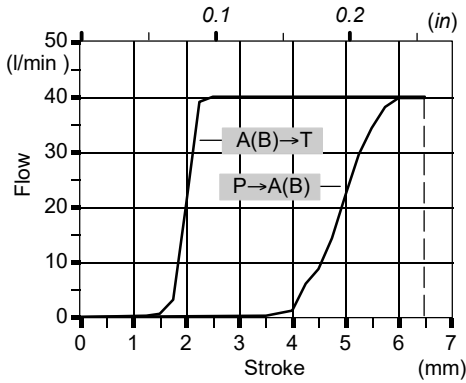

Pressure drop on series connection

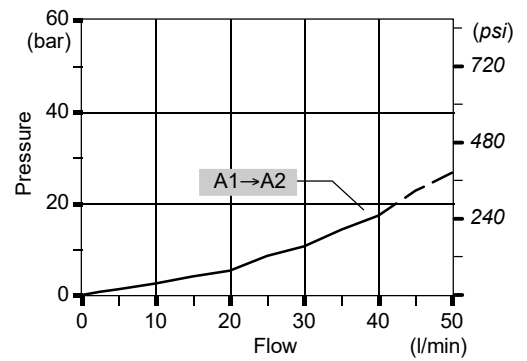

Type 2S01

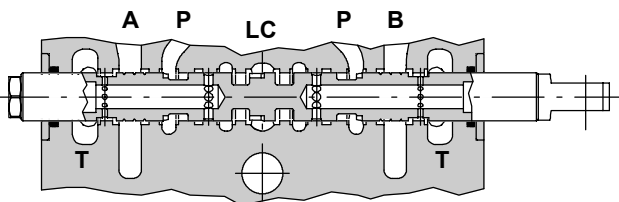

+ 6.5 mm / + 0.26 in
 (1) ▶
 ◀▶ (0)
 ◀ (2)
 - 6.5 mm / - 0.26 in

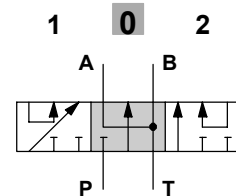

P closed, A-B to tank, with flow through line (LC) open

Type 801

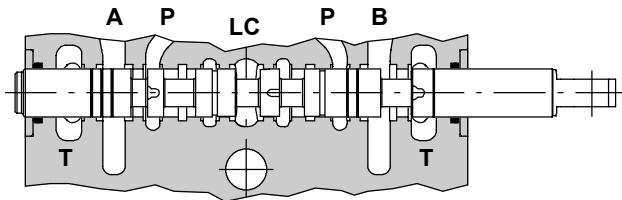

P → A B → T

▶ stroke + 6.5 mm
+ 0.26 in

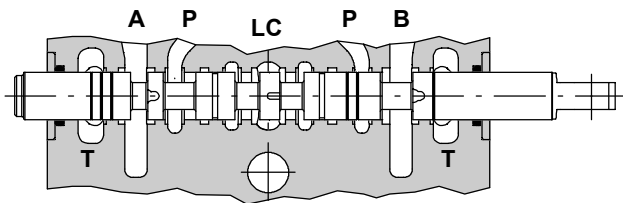
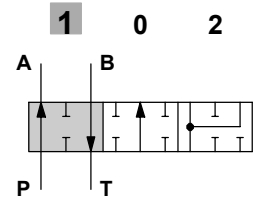

P-A-B-T closed, with flow through line (LC) open

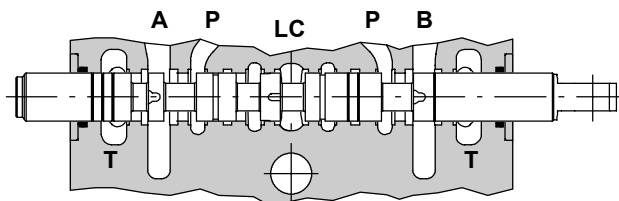
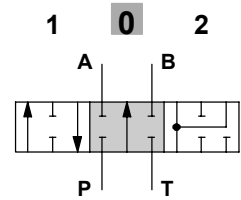

P+B → A (regenerative)

◀ stroke - 6.5 mm
- 0.26 in

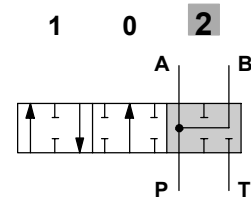

Performance data

Spool metering

$Q_{in} = 40 \text{ l/min} / P_{(on ports)} = 100 \text{ bar} / 1450 \text{ psi}$
0.1 0.2 (in)

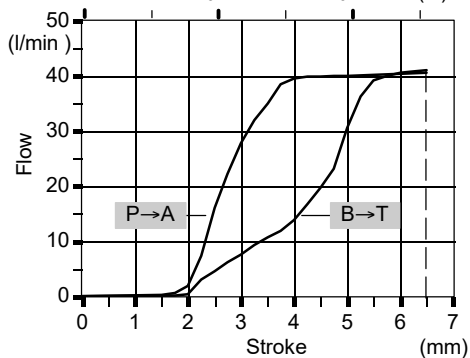

Pressure drop in position 2

(last section)

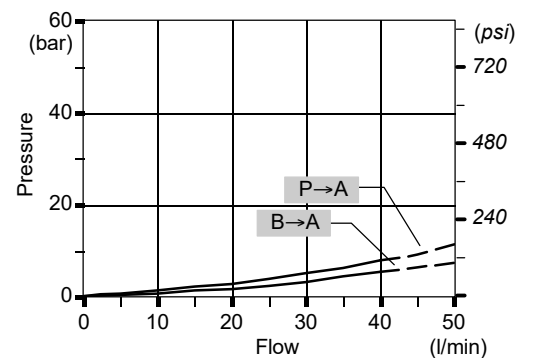

Type 501

Q5 - P5 section or RQ5 - RP5 optional outlet section required, contact Sales Dpt. for further information.

To be combined with 13 or 13F spool positioners (see page 39).

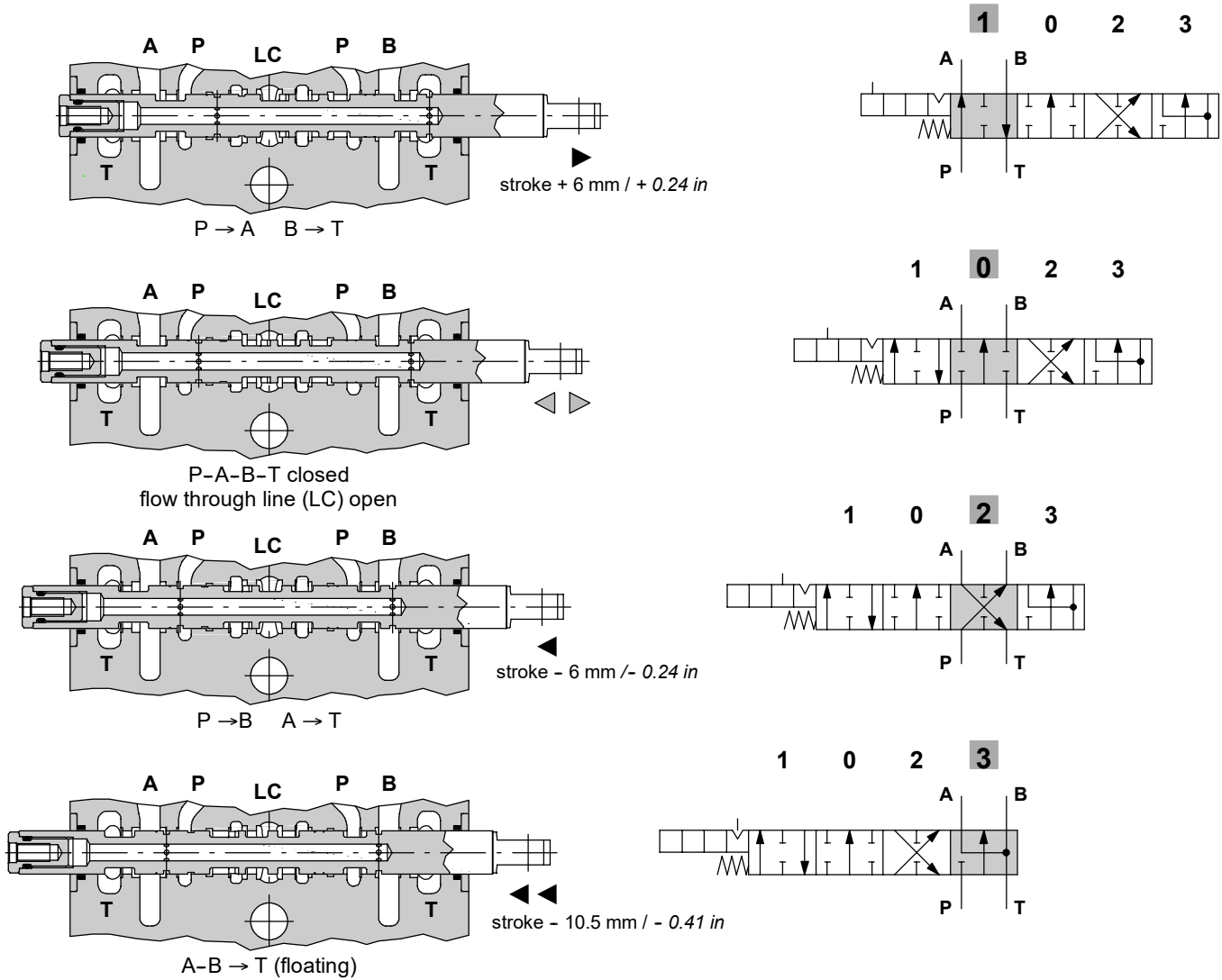

Performance data

Spool metering

$Q_{in} = 40 \text{ l/min} / P_{(on ports)} = 100 \text{ bar} / 1450 \text{ psi}$

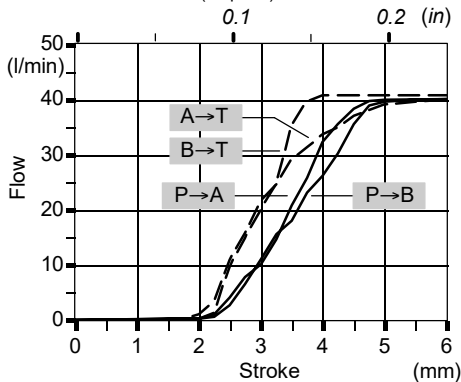

Pressure drop in position 3

(last section)

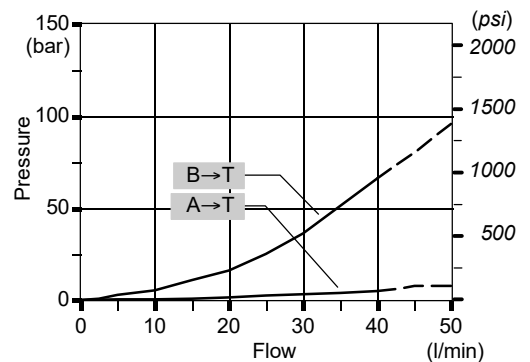

With friction type 7FTN

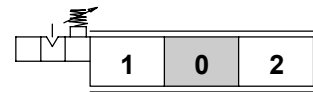
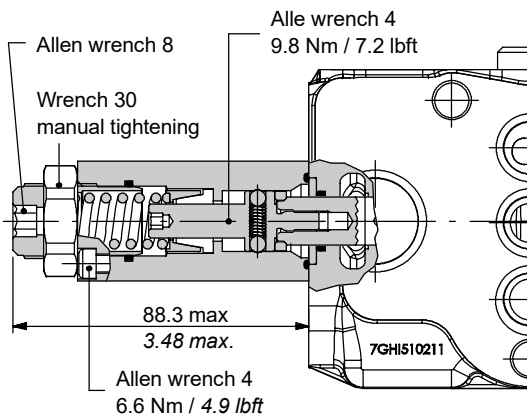

Spring return in neutral position

Type 8

It's standard configured with spring type B (see diagram); it's also available with heavier springs type C (8MC codice: 5V08207000) or type D (8MD codice: 5V08307000).

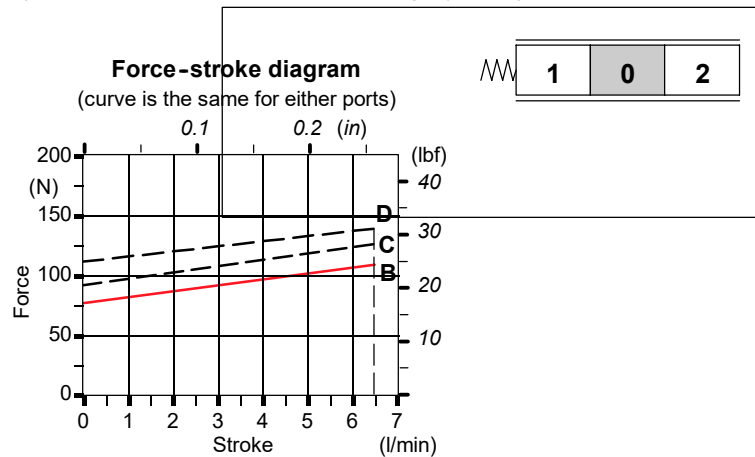
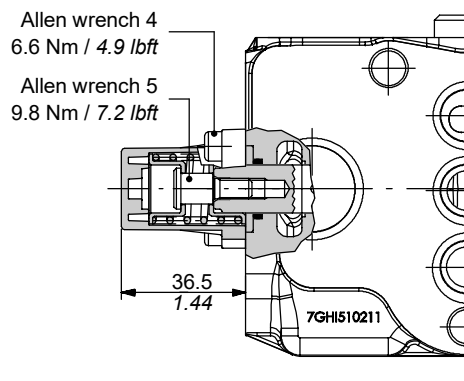

Type 8D

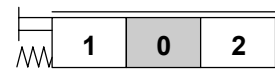
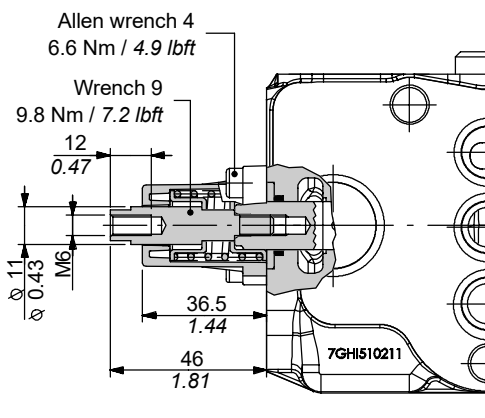

"A" side spool positioners

Spring return in neutral position

Type 8F2

With spool stroke adjustment in position 2 (P→B).

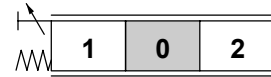
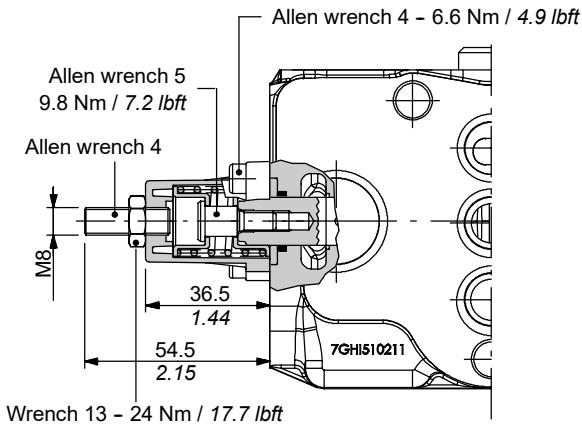

Type 8TL

For connect the kit 8TL to flexible cable always ask the following kits:

- type **CP50** code **5TEL405005**, with fixed cap for CG cables with revolving end.
- type **TQ50** code **5TEL105110**, with revolving cap for CD cables with fixed end.

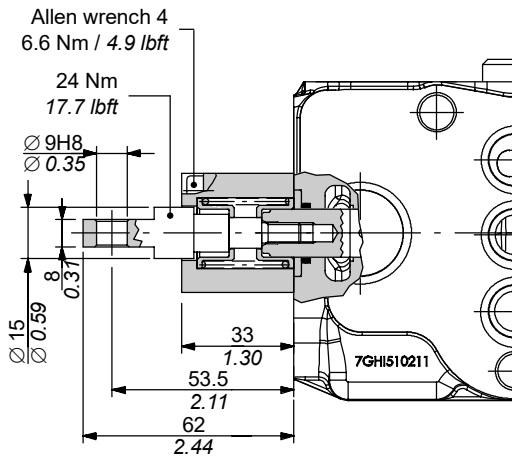
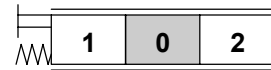

Positioner type 8TL with kit CP50

Positioner type 8TL with kit TQ50

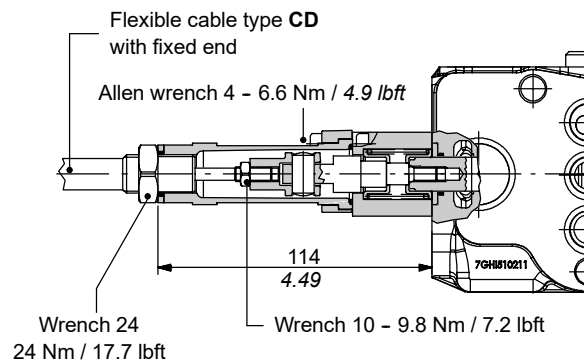
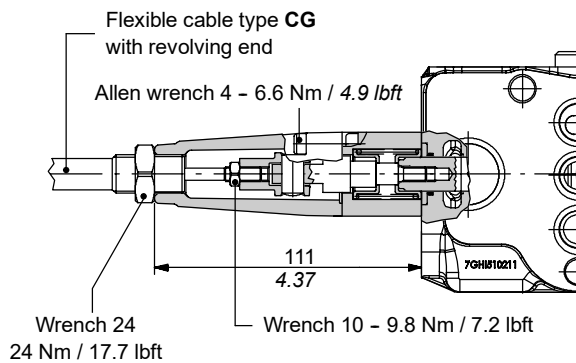

With detent and spring return to neutral position from either directions

Type 9B

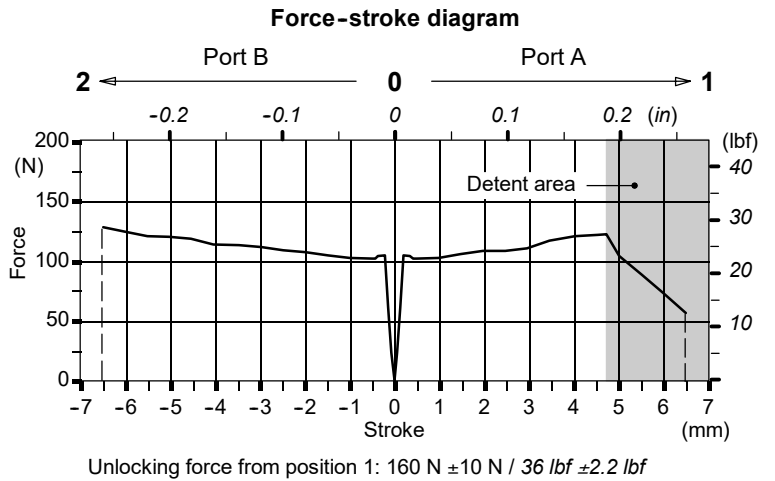
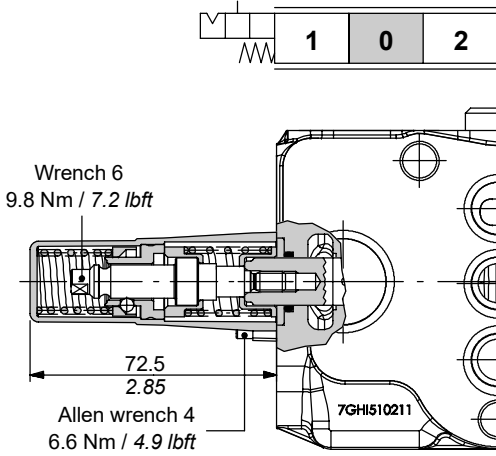

Type 10B

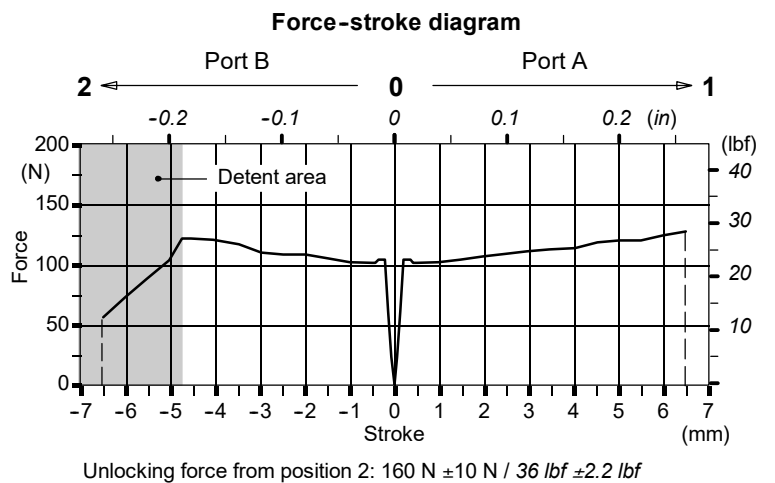
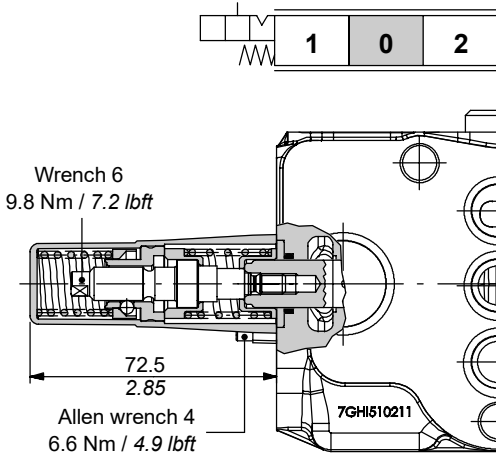

Type 11B

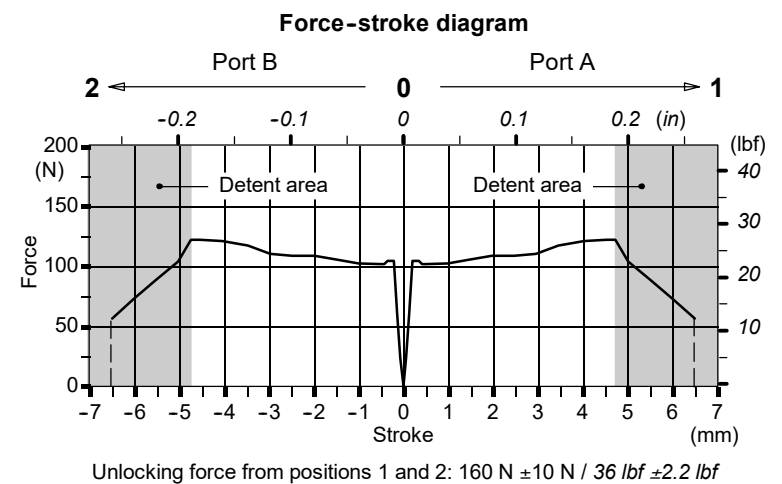
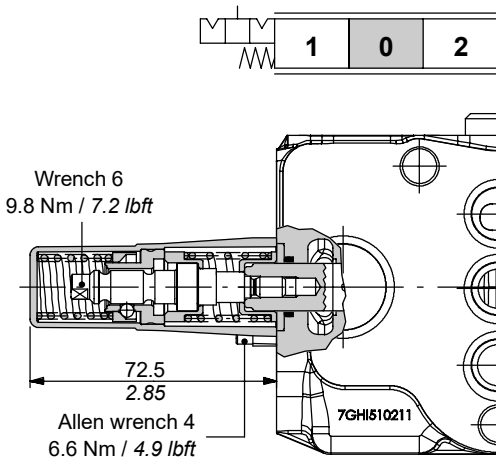

"A" side spool positioners

Electromagnetic detent type 8RM2

With electromagnetic detent in position 2 and spring return to neutral position.

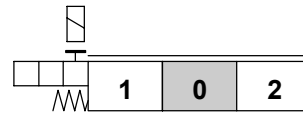
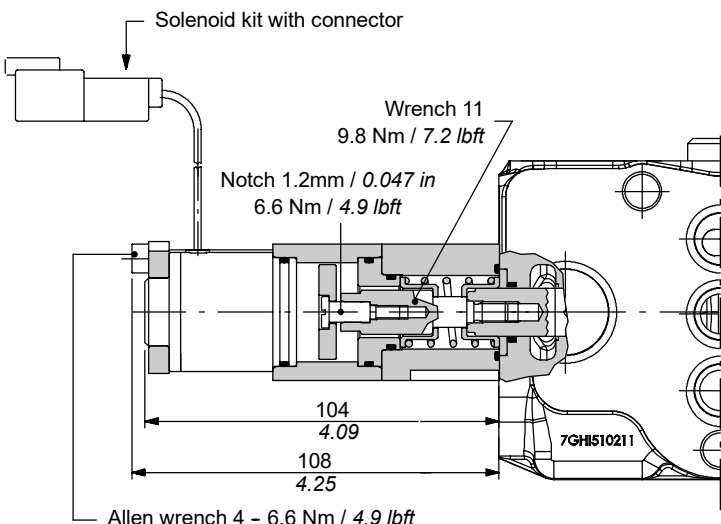

Operating features

COIL

Nominal voltage	: 12 / 24 VDC ± 10%
Power rating	: 5.5 W
Resistance (20 °C)	: 26.5 / 105 Ohm
Min unlocking force	: 45 N / 49.5 lbf
Duty cycle	: 100%

COMPLETE CONTROLS CODE

	CONNECTOR TYPE		
	Deutsch DT	AMP	Packard M-Pack
	CONTROL DESCRIPTION		
Voltage	8RM2	8RM2A(200)	8RM6
12 VDC	5V08107590	5V08107595	5V08107597
24 VDC	5V08107591	5V08107596	5V08107598
Need connector (page 96)	C16	C21	C20

COILS CODES

Voltage	CONNECTOR TYPE		
	Deutsch DT	AMP	Packard M-Pack
12 VDC	YSOL532455	YSOL532452	YSOL532451
24 VDC	YSOL532456	YSOL532458	YSOL532457

Coil with Deutsch DT connection

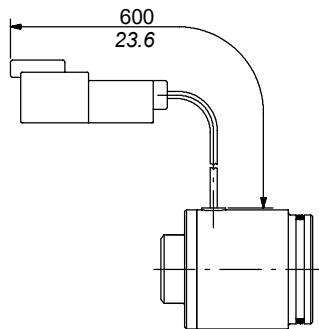

Coil with AMP Fastin-Faston connection

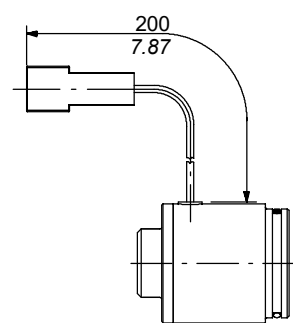

Coil with Packard M-Pack connection

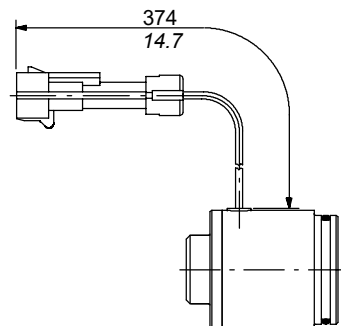

“A” side spool positioners

With microswitch type 8MG3(NO)

With spring return in neutral position and microswitch operated in both directions.

Also available **8MG1(NO)** configuration (microswitch operated in position 1) and **8MG2(NO)** configuration (microswitch operated in position 2); dimensions are the same of 8MG3 configuration.

Same configurations are available with normally closed (NC) contact.

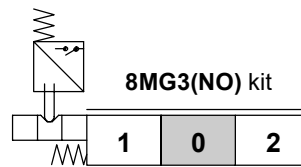
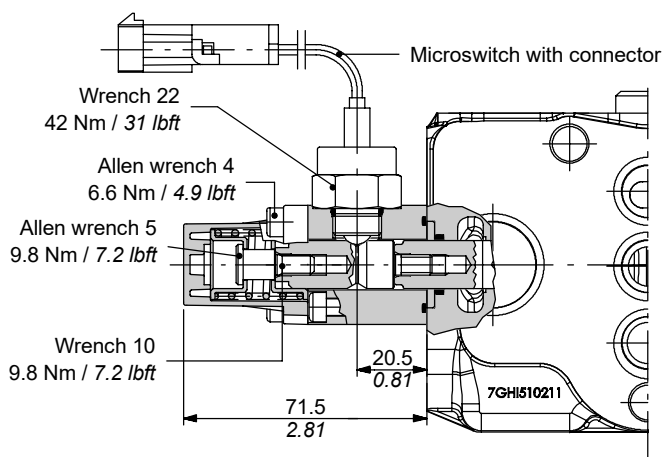

Other configurations

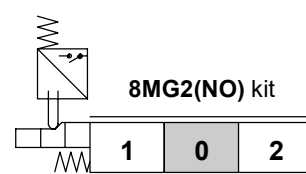
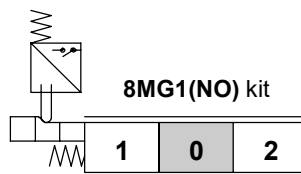

COMPLETE CONTROLS CODE

Contact type	CONTROLS DESCRIPTION			Need connector type
	8MG3	8MG2	8MG1	
NO	5V08107660	5V08107680	5V08107670	C07
NC	5V08107661	5V08107681	5V08107671	C17

see page 96

Operating features

MICROSWITCH

- Mechanical life : 5x10⁵ operations
- Electrical life (resistive load) : 10⁵ oper. - 7A / 13,5VDC
- : 5x10⁴ oper - 10A / 12VDC
- : 5x10⁴ per - 3A / 28VDC

More configurations and spare parts

It's possible to obtain further configurations of complete control, using the MG kit, microswitches and 3 positions “A” side spool positioner, as following draw.

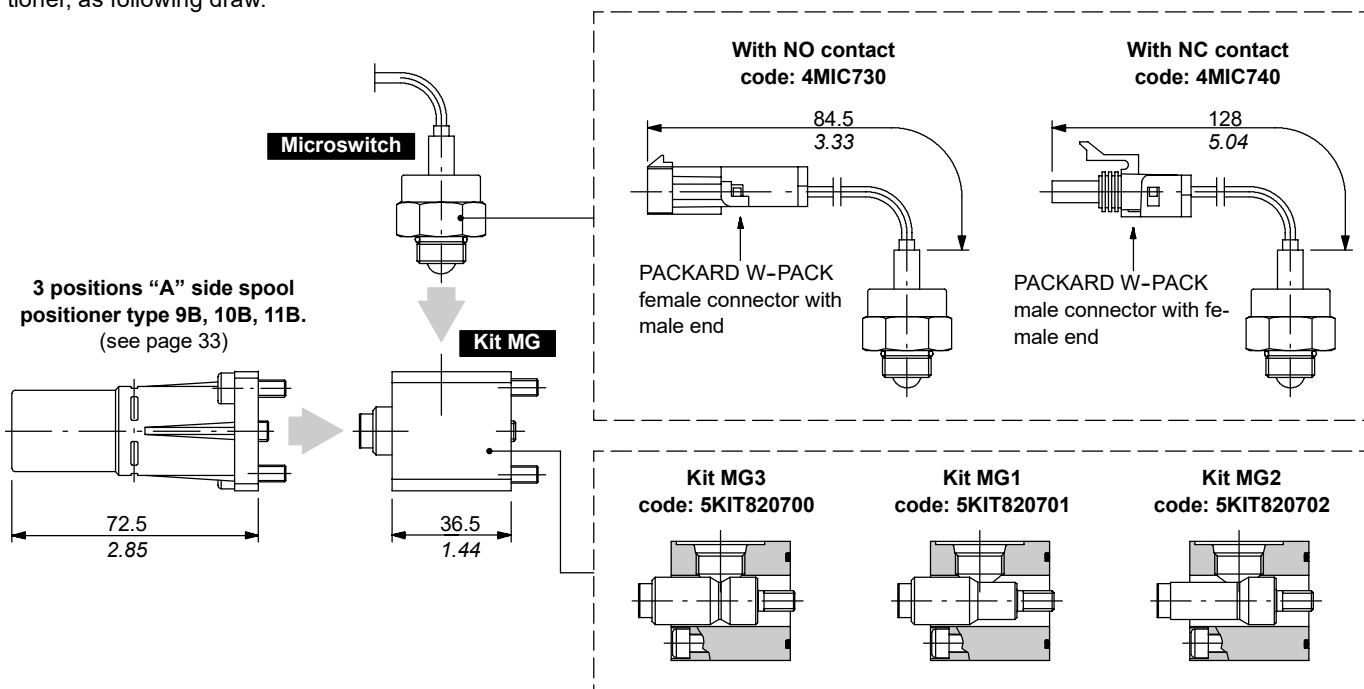

"A" side spool positioners

Spool solenoid lock device type 8K

With spring return and spool electromechanical lock in neutral position; when coil is feded the spool can be moved.

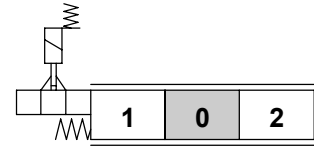
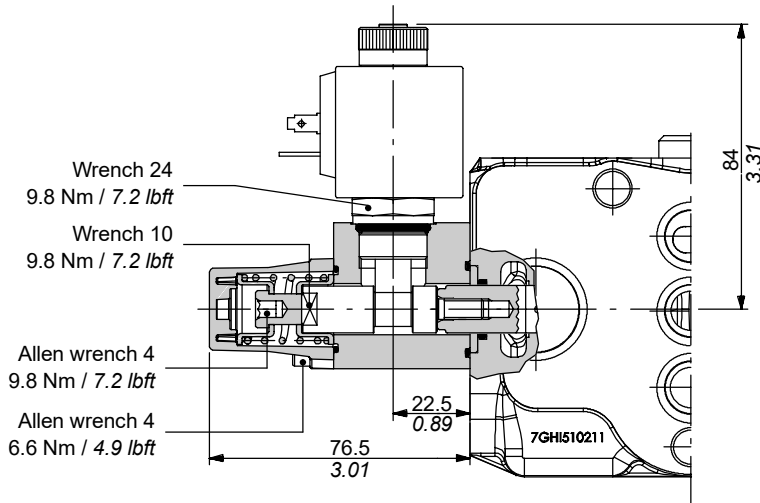

Operating features

ACTUATOR

Lock stroke : 3.5 mm / 0.14 in

COIL

Depending on model: see following features

COMPLETE CONTROLS CODE

CONNECTION TYPE

ISO4400 Deutsch DT Packard M-Pack

CONTROL DESCRIPTION

Voltage	8K	8K4	8K6
12 VDC	5V08707112	5V08707412	5V08707613
24 VDC	5V08707124	5V08707424	5V08707624
Need connector (page 96)	C02	C19	C20

COILS CODES

CONNECTOR TYPE

Voltage	ISO4400	Deutsch DT	Packard M-Pack
12 VDC	2X4300012	YSOL300015	YSOL300014
24 VDC	2X4300024	YSOL300026	YSOL300024

Coil with ISO4400 connector

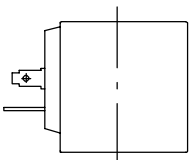

Nom. voltage tolerance .. : ±10%

Power rating : 18 W

Nominal current : 1.58 A - 12 VDC
: 0.81 A - 24VDC

Coil insulance : Class F

Weather protection : IP65

Duty : 100%

Coil with Deutsch DT connector

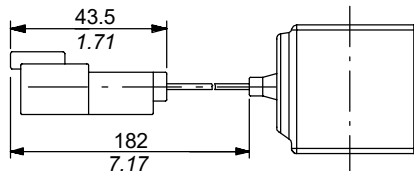

Nom. voltage tolerance .. : ±10%

Power rating : 18 W

Nominal current : 1.58 A - 12 VDC
: 0.81 A - 24VDC

Coil insulance : Class F

Weather protection : IP67

Duty : 100%

Coil with Packard M-Pack connector

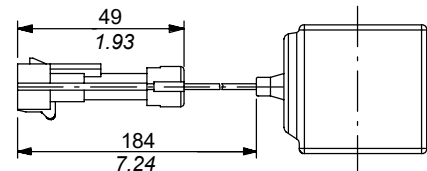

Nom. voltage tolerance .. : ±10%

Power rating : 18 W

Nominal current : 1.58 A - 12 VDC
: 0.81 A - 24VDC

Coil insulance : Class F

Weather protection : IP65

Duty : 100%

“A” side spool positioner

Solenoid lock device type 8K

More configurations and spare parts

It's possible to obtain further configurations of complete control, using the K kit, coils and 3 positions “A” side spool positioner, as following draw: for information contact Sales Department.

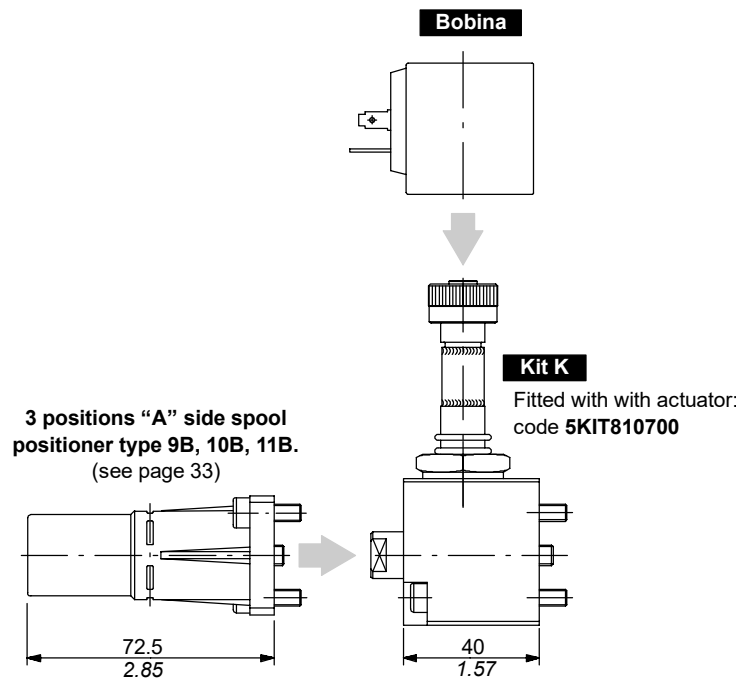

Proportional pneumatic control type 8PP

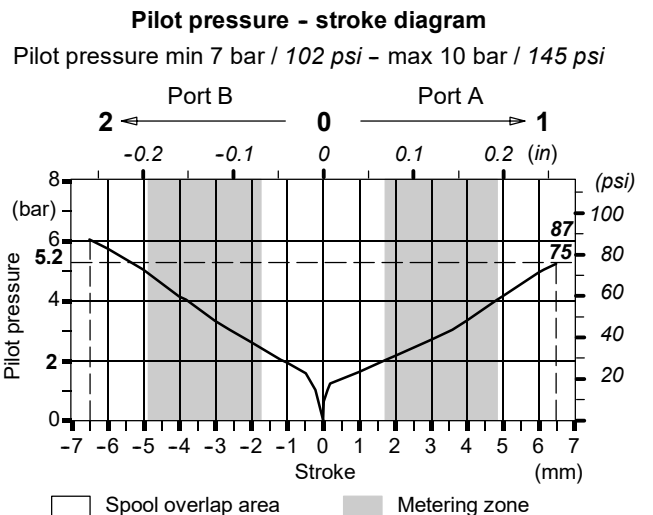
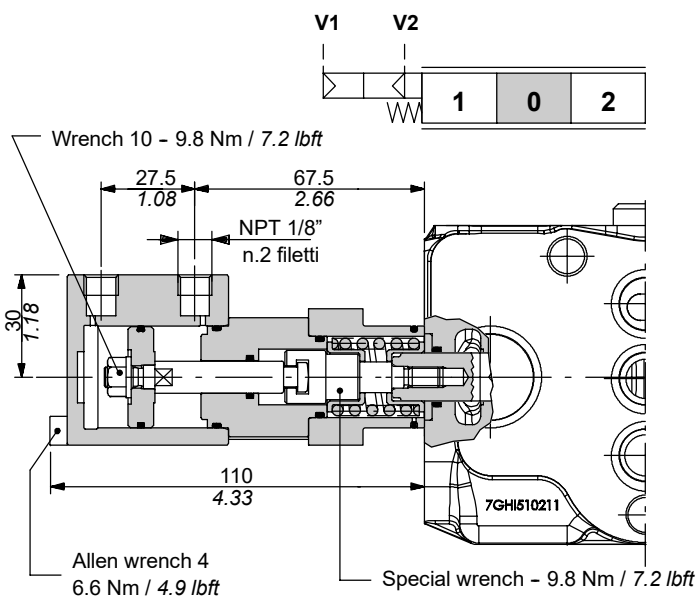

"A" side spool positioners

ON/OFF electro-pneumatic control type 8EP3

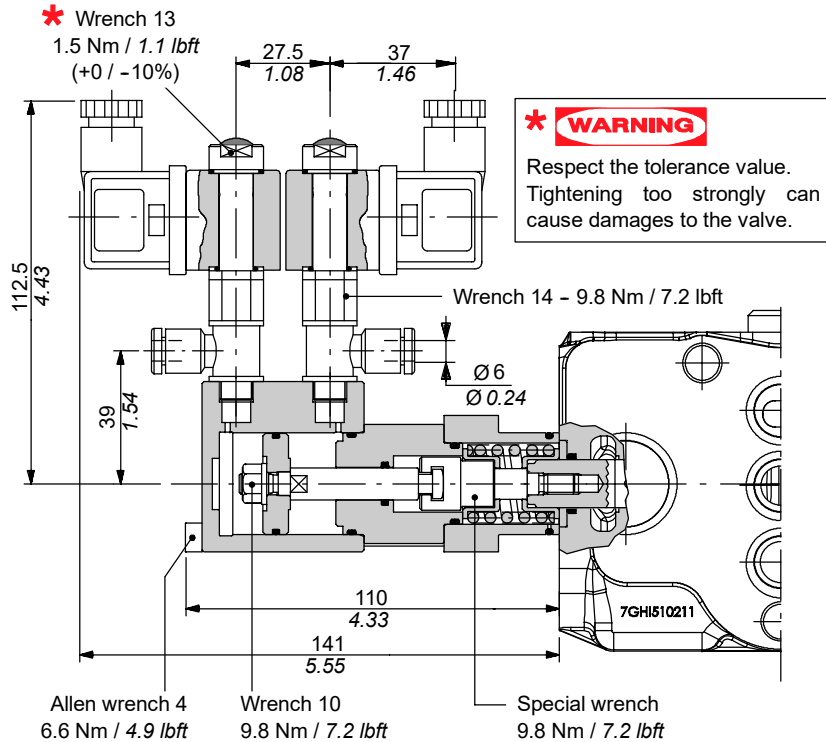

Scheme

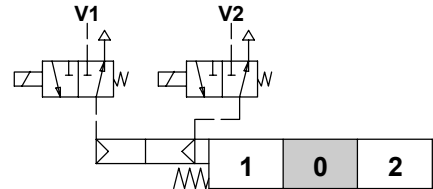

Scheme ISO 1219

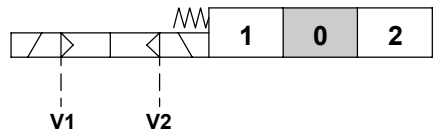

COMPLETE CONTROL CODE

	CONNECTION TYPE	
	ISO6952	Flying leads
	CONTROL TYPE	
	8EP3	8EP35
Voltage	5V08107735	5V08107736
12 VDC	5V08107740	5V08107741
24 VDC		
Need connector (page 96)	C01 (included)	/

Operating features

CONTROL

Pilot pressure : 6 bar - 87 psi
(max.10 bar - 145 psi)

COIL

Nominal voltage tolerance : ±10%
Power rating : 8 W
Nominal current : 0.67 A - 12 VDC
: 0.33 A - 24VDC
Coil insulation : Class H
Weather protection : IP65
Duty cycle : 100%

COILS CODE

Voltage	CONNECTION TYPE	
	ISO6952	Flying leads *
12 VDC	2XB1010121100	2XB1010120000
24 VDC	2XB1010241100	2XB1010240000

* Several type of connectors can be wired on request

Coil with ISO6952 connector

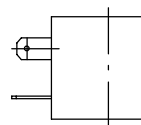

Coil with flying leads

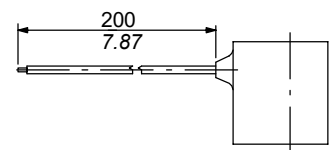

Positioners for special spools

Kit 13

With detent in position 3 (floating) and spring return to neutral from either directions.
Available for spool type 501 (see page 30).

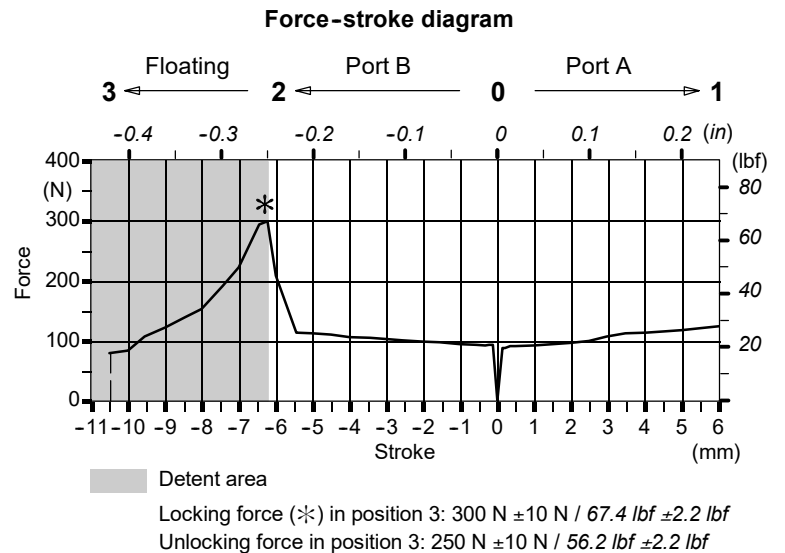
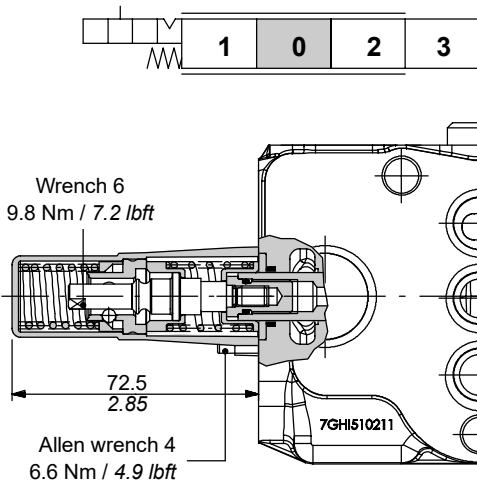

Kit 13F

With additional spring in position 3 (floating) and spring return to neutral from either directions.
Available for spool type 501 (see page 30).

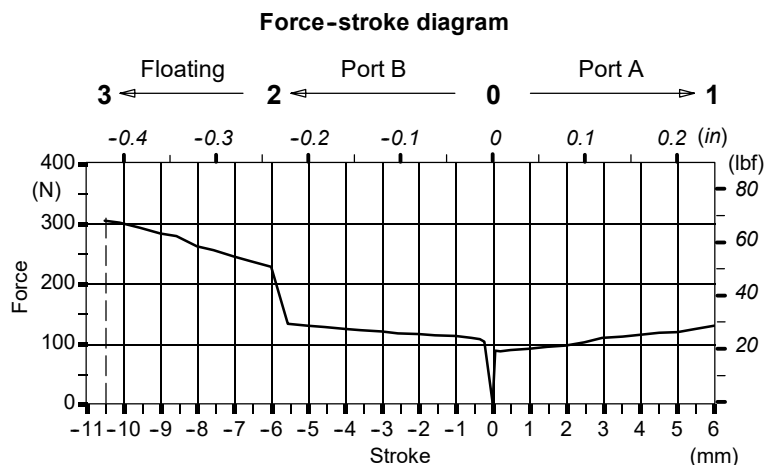
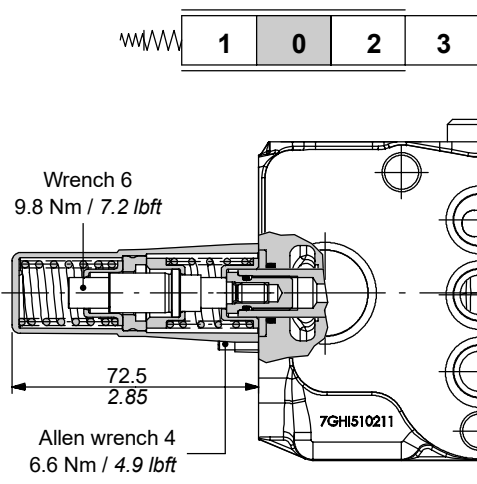

Lever control

Type L

Zama (zinc alloy) lever pivot box with protective rubber bellow; it can be rotated 180° (configuration L180).

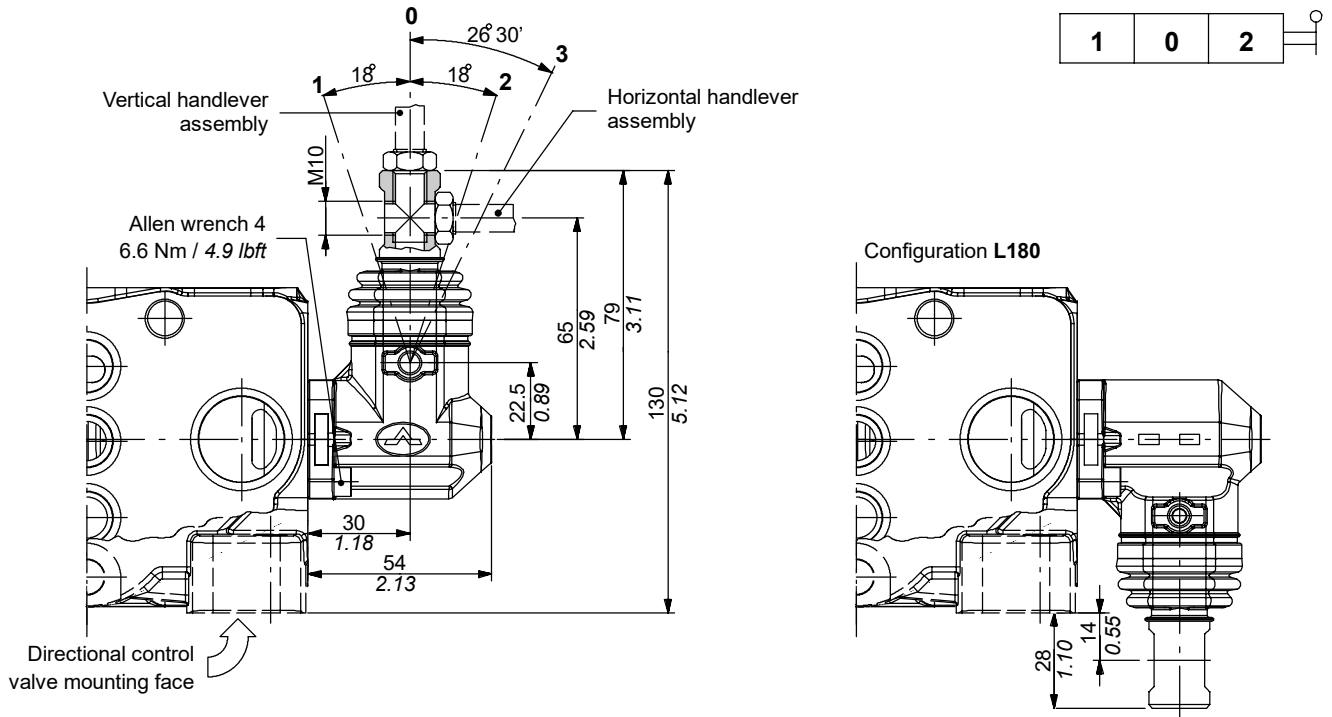

Type LF1

With spool stroke adjustment in position 1 (P→A); it can be rotated 180° (configuration LF1180).

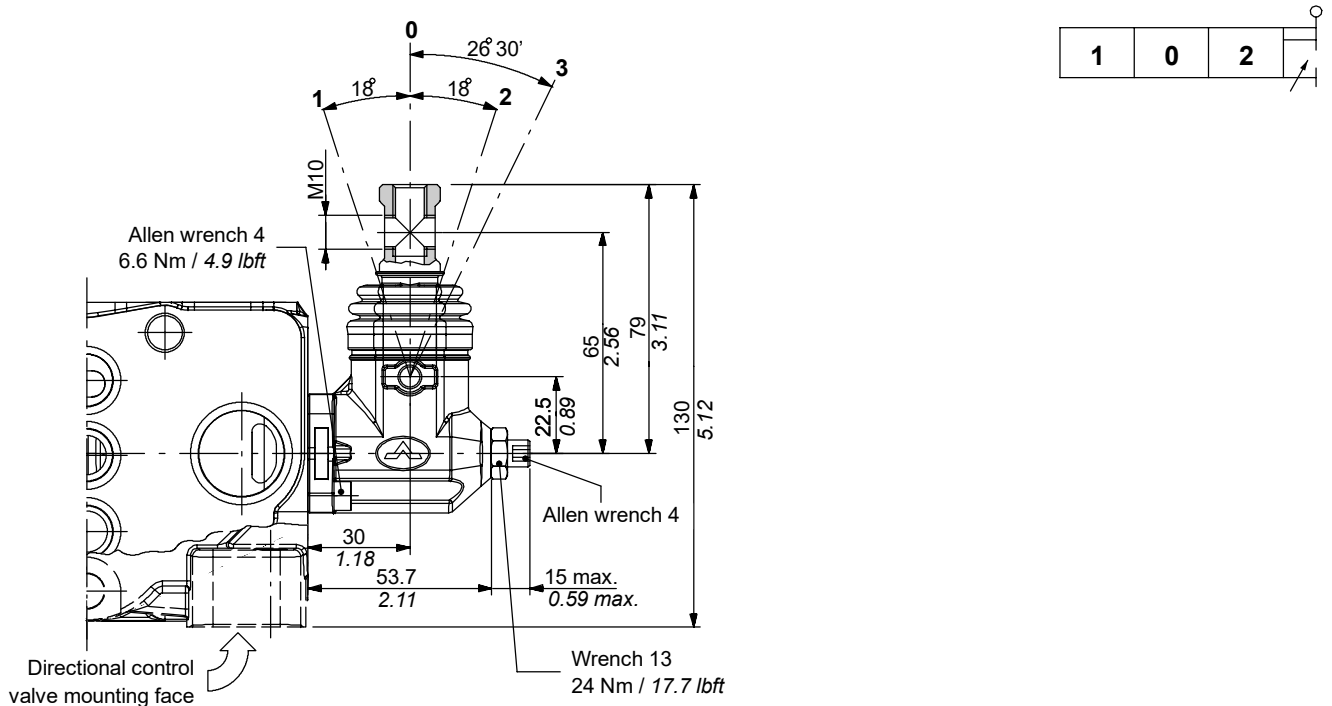

"B" side options

Lever control

Type LB3

Steel lever control, with pivot placed above; the particular construction makes it suitable for heavy duty applications. It can be rotated 180° (configuration **LB3180**).

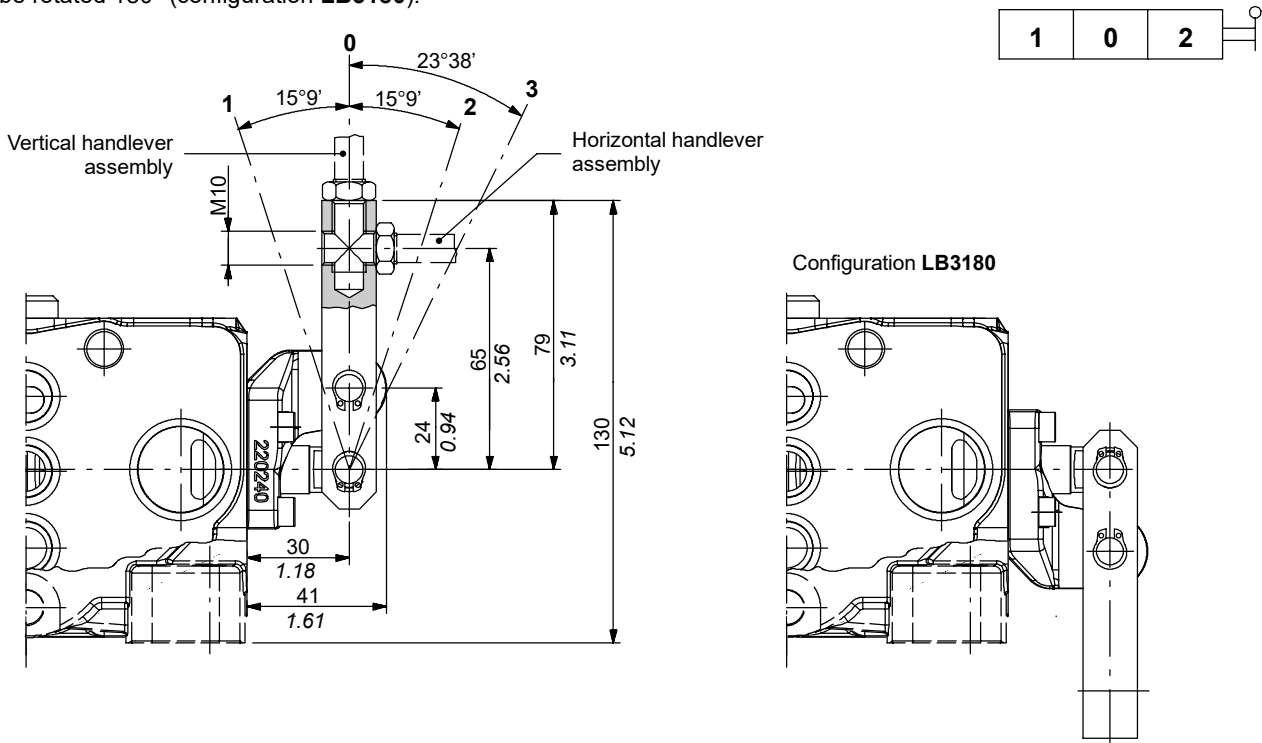

Controls arrangement

Type SLC

Protection cap usable with 8PP pneumatic or 8EP3 electro-control

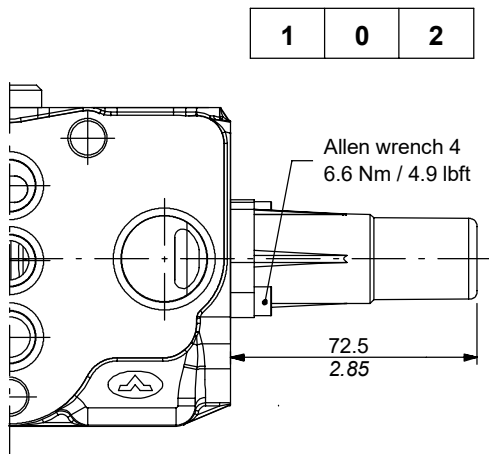

Type SLP

Mechanical control with dust-proof plate kit.

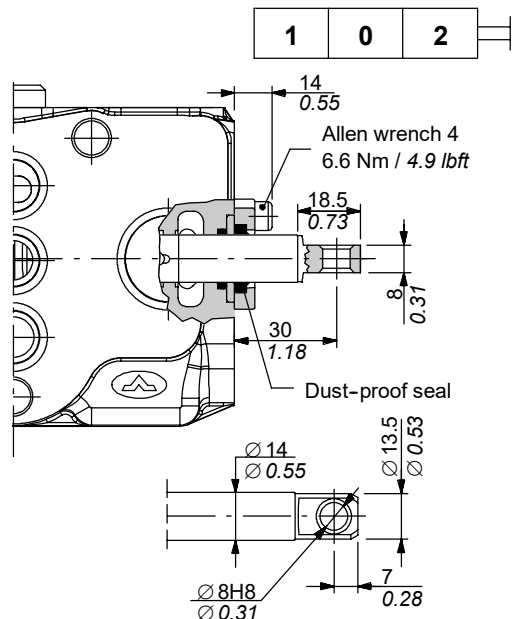

Joystick type LCA

For 2 sections operation and available in two different configurations LCA1-4 e LCA2-3 for two assembling mode (see following pages).

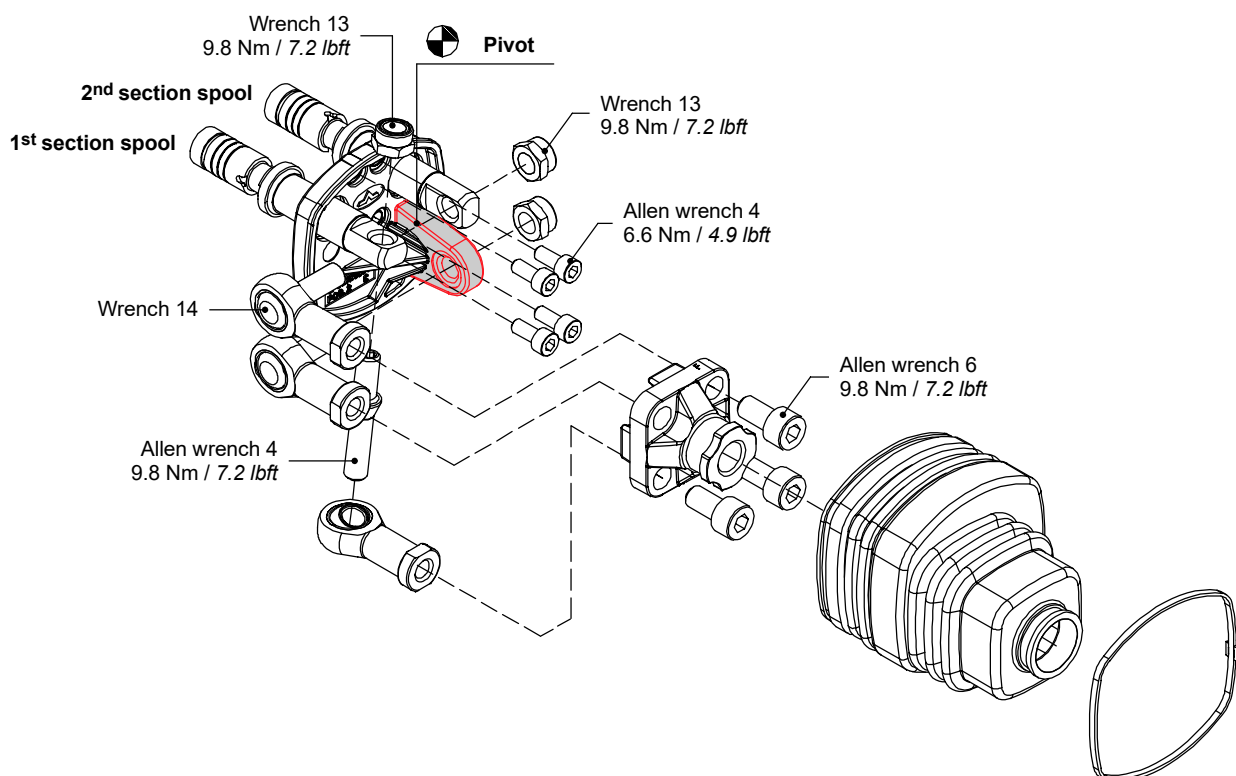
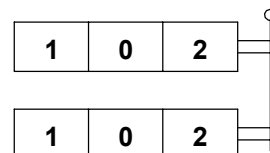

NOTE - The handlever must be ordered separately (see page 21).

"B" side options

Joystick type LCA

Configuration LCA1-4

LCA1 and LCA4 configurations can be obtained by rotating the flange/fulcrum block by 180°.

Assembling mode LCA1: pivot placed down on the left

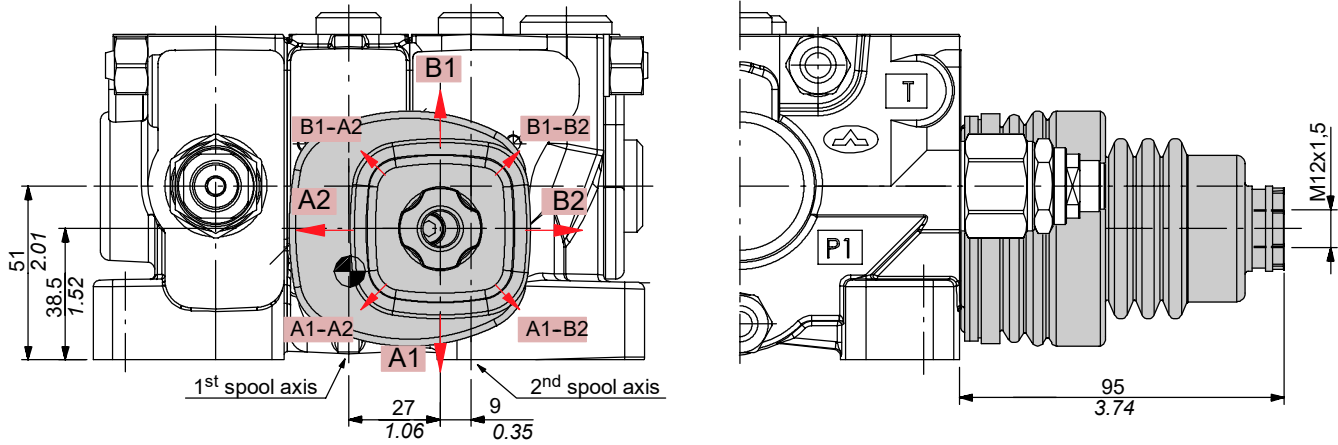

Assembling mode LCA4: pivot placed above on the right

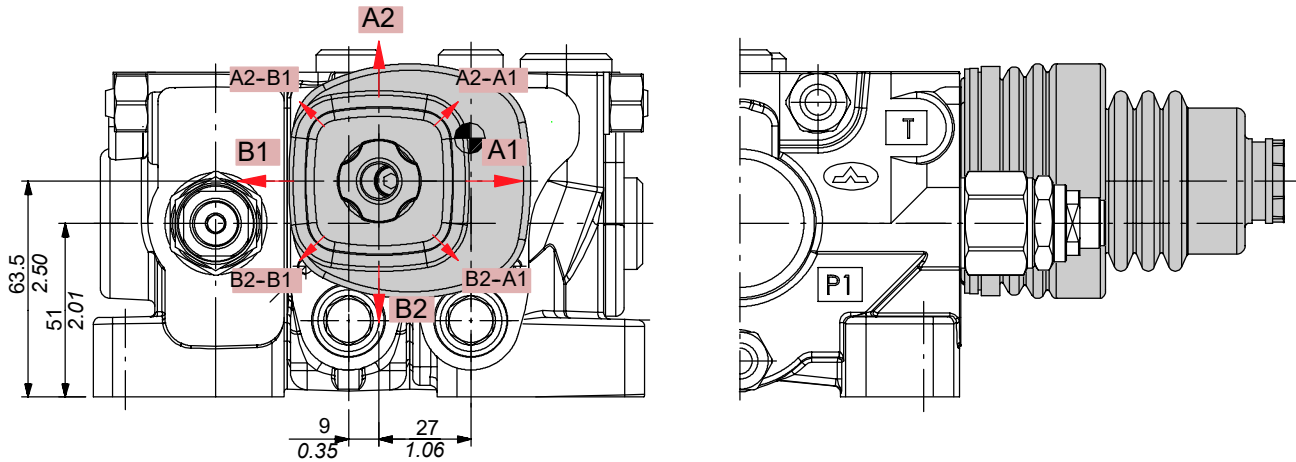

Operation angle

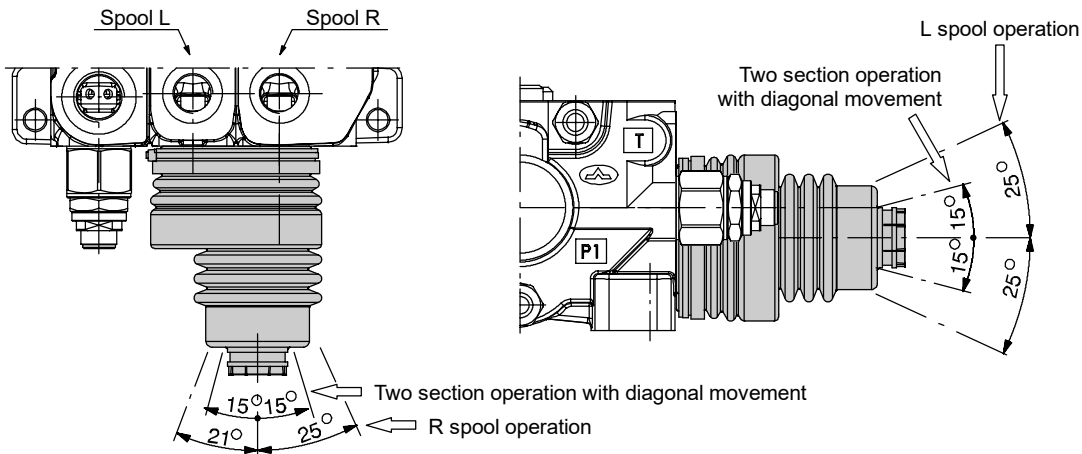

Joystick type LCA

Configuration LCA2-3

LCA2 and LCA3 configurations can be obtained by rotating the flange/fulcrum block by 180°.

Assembling mode LCA2: pivot placed down on the right

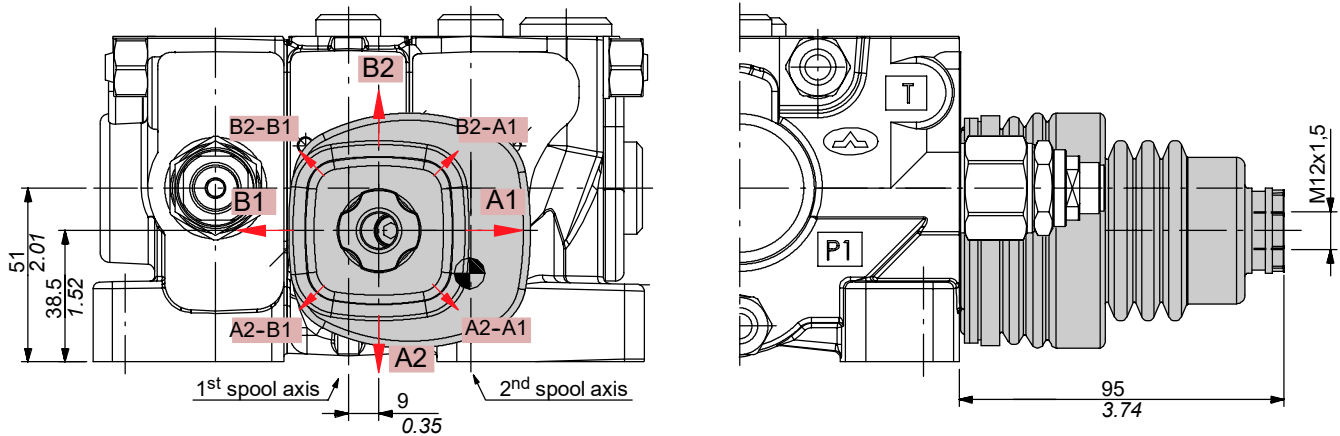

Assembling mode LCA3: pivot placed above on the left

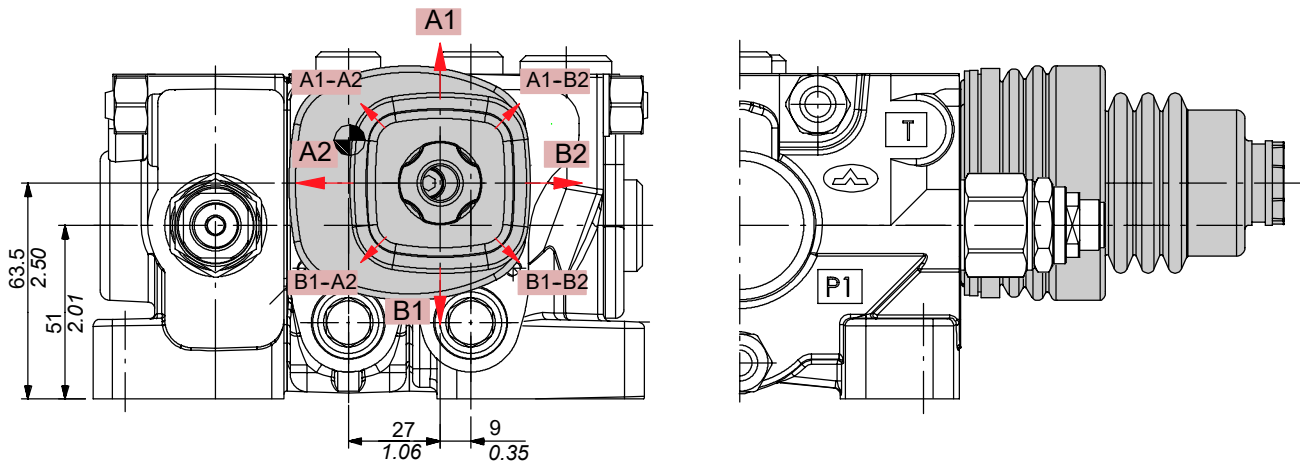

Operation angle

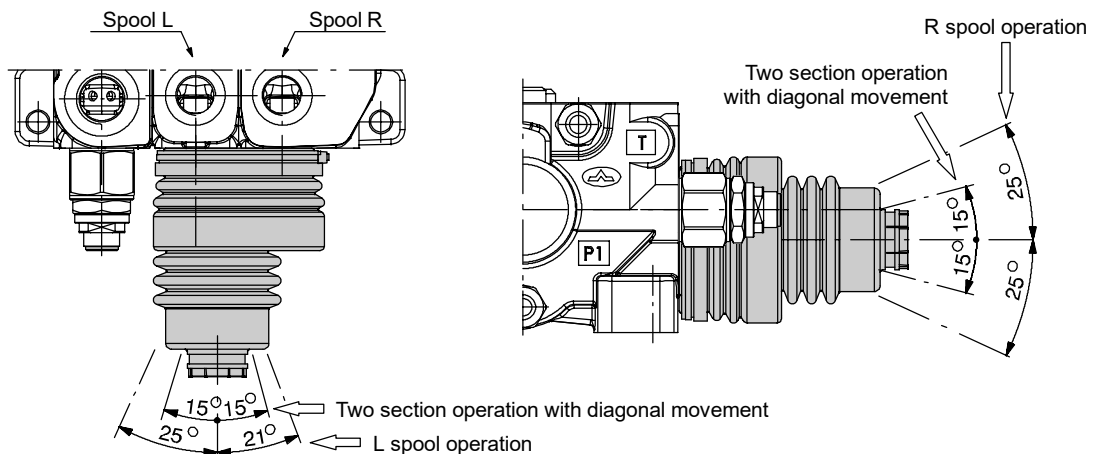

"B" side options

Spool solenoid lock device type STK

With spring return and spool electromechanical lock in neutral position; when coil is feeded the spool can be moved.

The control kit doesn't include the coil, that has to be ordered separately and needs special spools.

For information about other "B" side controls with electromechanical lock, contact Sales Department

COILS CODE

Voltage	CONNECTION TYPE		
	ISO4400	Packard M-Pack	Deutsch DT
12 VDC	2X4300012	YSOL300014	YSOL300015
24 VDC	2X4300024	YSOL300024	YSOL300026
Need connector. (page 96)	C02	C20	C19

3 positions "A" side spool positioners
(see page 31) to couple with spool type **B102**

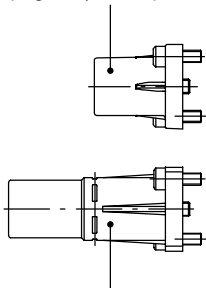

3 positions "A" side spool positioners
(see page 39) to couple with spool type **B501**

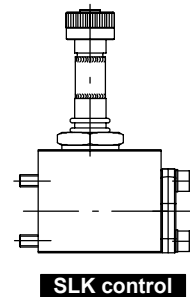
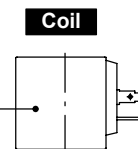
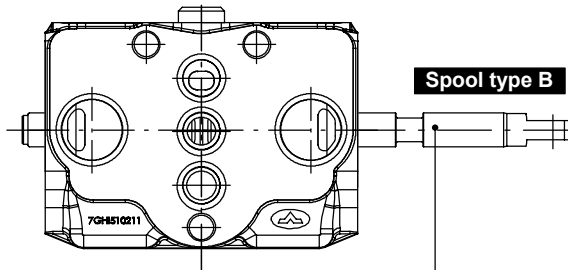

SPOOLS CODE

Type	Code	Description
B102	3CU6310102	Double acting, 3 positions, with A and B closed in neutral position
B501	3CU6342501	Double acting, 4 positions, floating in 4 th positions with spool in: Q5 - P5 section or RQ5 - RP5 optional outlet section required

If not specified otherwise, the spool are from 20 to 40 l/min flow

Complete controls

8ES solenoid control

Solenoid direct control with spring return to neutral position; it needs special spools and standard working section body (body kit without seals on spool).

Description example:

EL SDS100 / Q - S102 - 8ES3 - 24VDC *

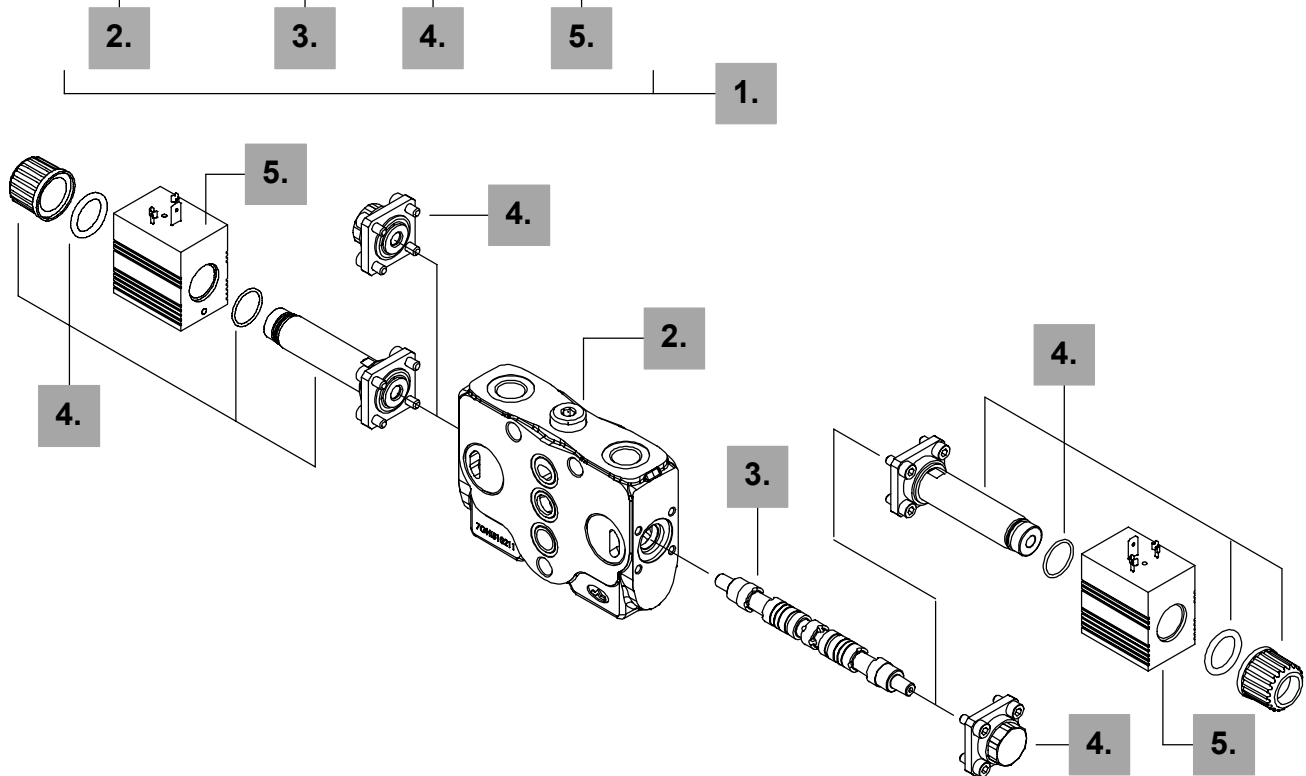

1. Complete working section *

TYPE: **Q-S102-8ES3-24VDC** CODE: 610101002
DESCRIPTION: Parallel circuit with 3 positions double acting spool, ON/OFF solenoid control

TYPE: **RQ-S102-8ES3-24VDC-F** CODE: 610351004
DESCRIPTION: Working section with optional outlet fitted out previous
NOTE: for working sections codes with port valves prearrangement contact Sales Department.

2. Working section kit *

TYPE	CODE	DESCRIPTION
Q/IM-ES	5EL107301A	Parallel circuit
P/IM-ES	5EL107300A	Parallel circuit with port valves prearrangement
SQ/IM-ES	5EL307301A	Tandem circuit
SP/IM-ES	5EL307300A	Tandem circuit with port valves prearrangement
RQ/IM-ES	5FIA20731A	Section with optional outlet and parallel circuit
RP/IM-ES	5FIA20730A	As previous with valves prearrangement

NOTE (*) - Codes are referred to **BSP** thread.

3. Spool

TYPE	CODE	DESCRIPTION
S102	3CU6810102	Double acting, 3 positions with A and B closed in neutral position

4. Control kits

TYPE	CODE	DESCRIPTION
8ES1	5V08028	P→A, with spring return in neutral position
8ES2	5V08028	P→B, with spring return in neutral position
8ES3	5V08029	Double acting with spring return in neutral position

5. Coils

With ISO4400 connection

10.5VDC	4SOL512011	Nominal voltage 10.5VDC
12VDC	4SOL512012	Nominal voltage 12VDC
24VDC	4SOL512024	Nominal voltage 24VDC

With Deutsch DT connection

4-10.5VDC	4SOL512111	Nominal voltage 10.5VDC
4-12VDC	4SOL512112	Nominal voltage 12VDC

8ES solenoid control

Electric wiring example

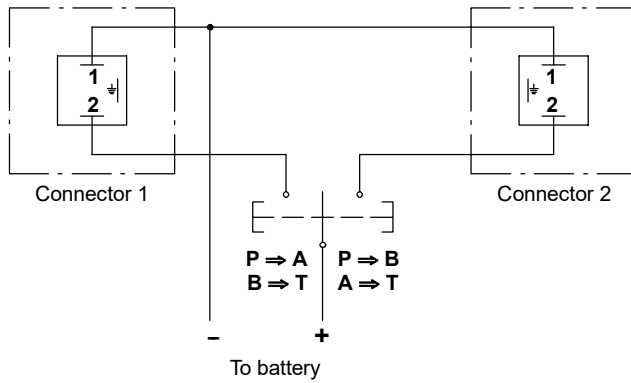

8ES3 kit double acting



8ES1 kit single acting on A

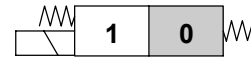

8ES2 kit single acting on B

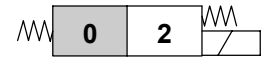

Operating features

CONTROLS

Fuga interna A(B)→T

($\Delta p = 100 \text{ bar} / T = 40^\circ\text{C}$) : 10 cm³/min - 0.61 in³/min

COILS

Nominal voltage tolerance : $\pm 10\%$

Power rating : 36 W

Coil insulation : class H

Duty cycle : 100%

Operating condition diagram

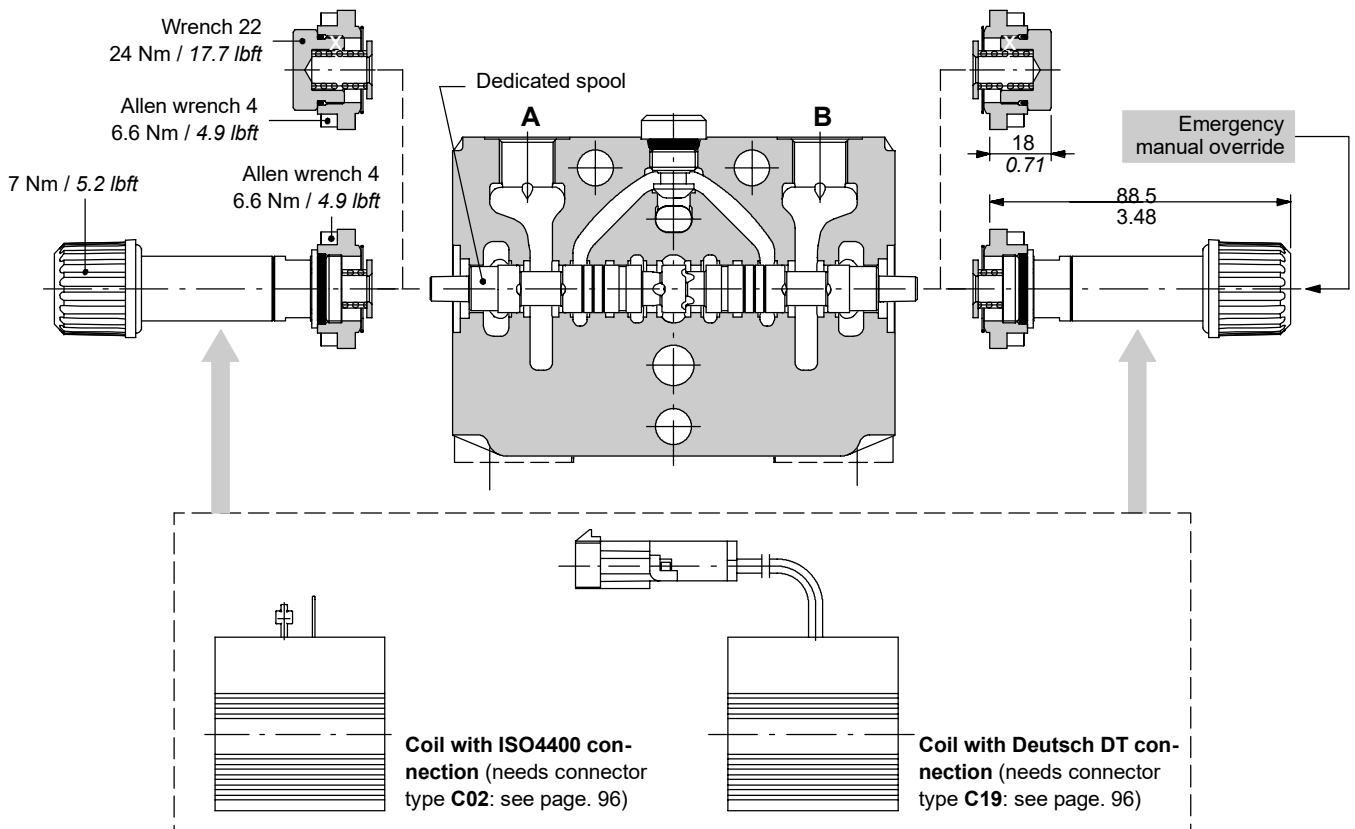
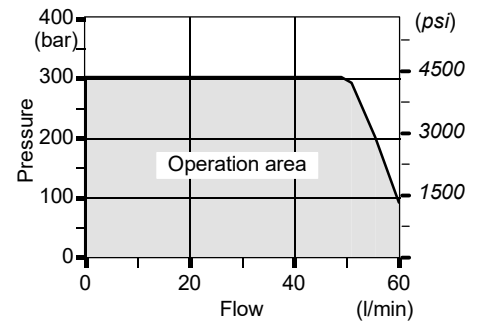

Complete controls

8IM proportional hydraulic control

It needs special spools and standard working section body (body kit without seals on spool).

Description example:

EL SDS100 / Q - I112 - 8IM *

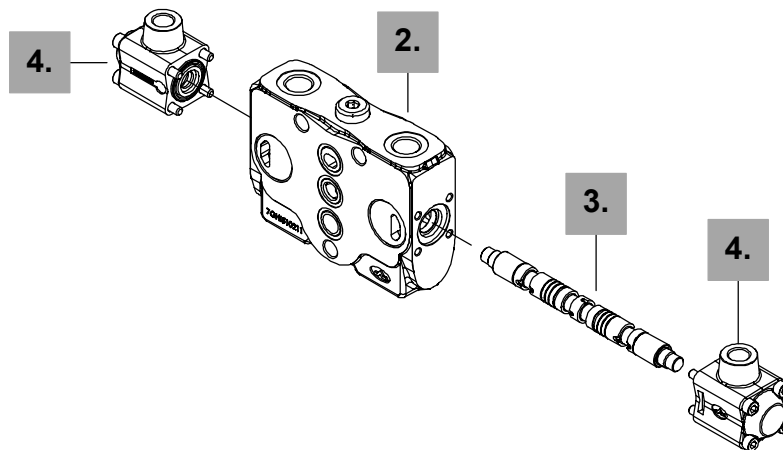
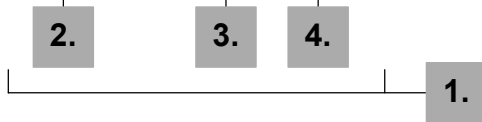

1. Complete working section *

TYPE: **Q-I112-8IM** CODE: 610101003
 DESCRIPTION: Parallel circuit with 3 positions double acting spool, proportional hydraulic control
 TYPE: **RQ-I112-8IM-F** CODE: 610351005
 DESCRIPTION: Working section with optional outlet fitted out previous
 NOTE: for working sections codes with port valves prearrangement contact Sales Department.

2. Working section kit *

TYPE	CODE	DESCRIPTION
Q/IM-ES	5EL107301A	Parallel circuit
P/IM-ES	5EL107300A	Parallel circuit with port valves prearrangement
SQ/IM-ES	5EL307301A	Tandem circuit
SP/IM-ES	5EL307300A	Tandem circuit with port valves prearrangement
RQ/IM-ES	5FIA20731A	Section with optional outlet and parallel circuit
RP/IM-ES	5FIA20730A	As previous with valves prearrangement

NOTE (*) - Codes are referred to **BSP** thread.

3. Spools

TYPE	CODE	DESCRIPTION
I118	3CU6410118	Double acting, 3 positions, with A and B closed in neutral position; for flow up to 20 l/min
I112	3CU6210420	As previous for flow from 20 to 40 l/min
I117	3CU6410117	As previous for flow from 40 to 60 l/min
I203	3CU6225420	Double acting, 3 positions, with A and B open to tank in neutral position; for flow from 20 to 40 l/min

4. Control kit *

TYPE	CODE	DESCRIPTION
8IM	5IDR207300	Double sides proportional hydraulic control with spring return in neutral position

8IM proportional hydraulic control

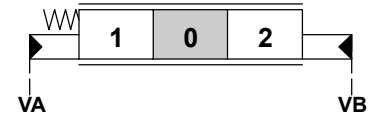
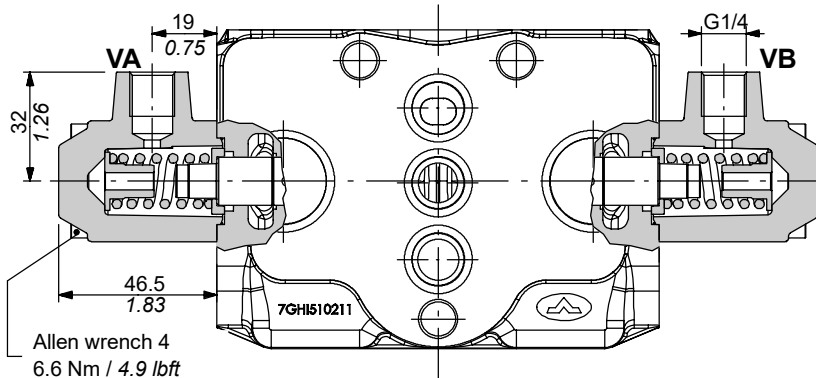

Operating features

Max pilot pressure 70 bar / 1015 psi

Pilot pressure - stroke diagram

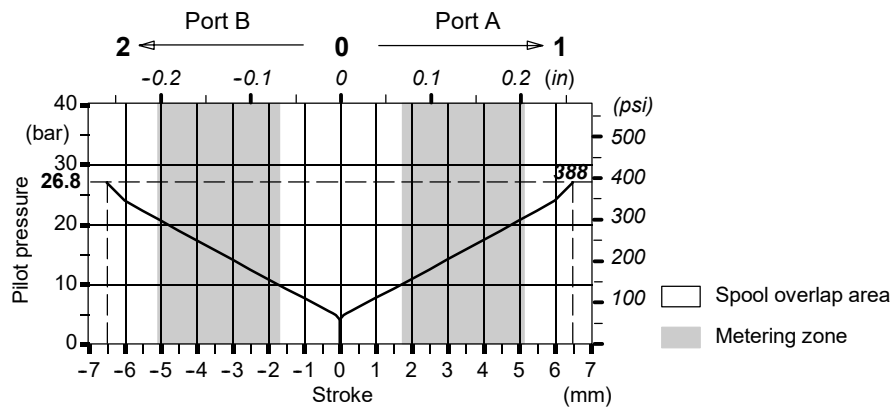

Connection example

Configuration for connection to the pilot valve with external pump (see previous page).

Configuration for direct connection from the directional control valve to the pilot valve.

- 1) CR inlet section with pressure reducing valve (see page 68)
- 2) PA or QA working section with pilot through and drain (see page 88)
- 3) RPA or RQA optional outlet working section with pilot through line closing and backpressure valve (see page 90).

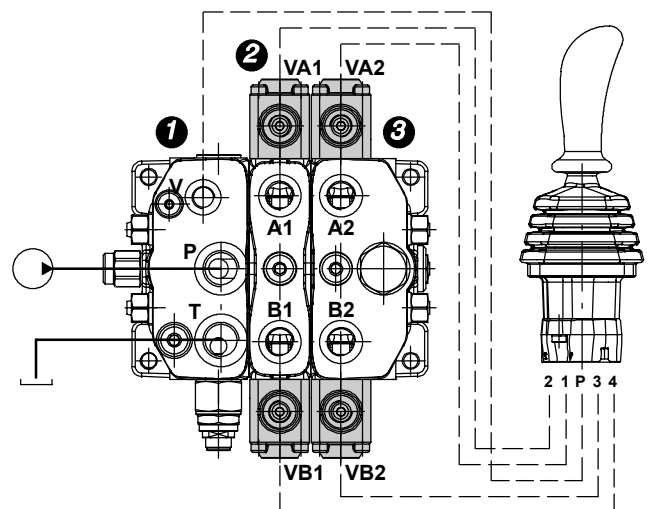
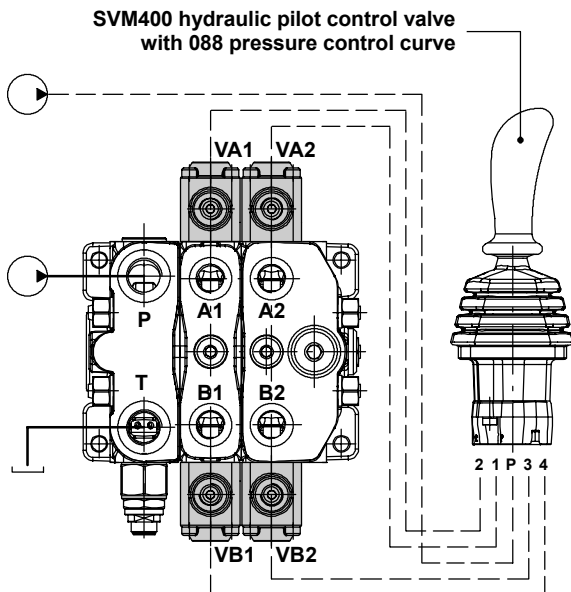

Complete controls

13IM proportional hydraulic control

It needs special spools and special working section body (body kit without seals on spool).

Description example:

EL SDS100 / Q - I501 - 13IM *

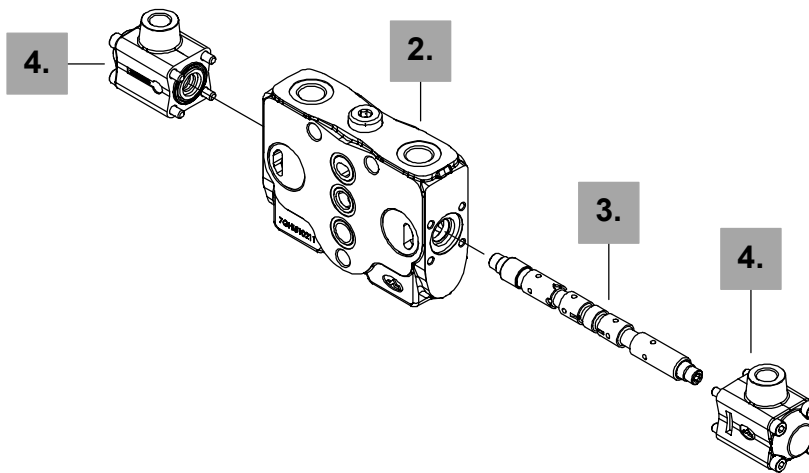
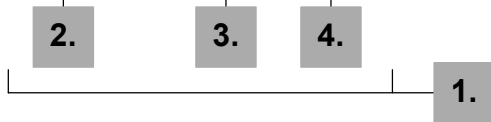

1. Complete working section *

TYPE: **P5-I501-13IM.UTUT** CODE: 610101600
 DESCRIPTION: Parallel circuit with port valves prearrangement, 4 positions double acting spool, floating in 4th position with spool in, proportional hydraulic control
 TYPE: **RP5-I501-13IM.UTUT** CODE: 610301600
 DESCRIPTION: Working section with optional outlet fitted out previous
 NOTE: for working sections codes without port valves prearrangement contact Sales Department.

2. Working section kit *

TYPE	CODE	DESCRIPTION
Q5/IM	5EL107321A	Parallel circuit
P5/IM	5EL107320A	Parallel circuit with port valves prearrangement
SQ5/IM	5EL307321A	Tandem circuit
SP5/IM	5EL307320A	Tandem circuit with port valves prearrangement
RQ5/IM	5FIA207315A	Optional outlet working section, with parallel circuit
RP5/IM	5FIA207305A	As previous with port valves prearrangement

NOTE (*) - Codes are referred to **BSP** thread.

3. Spools

TYPE	CODE	DESCRIPTION
I503	3CU6442000	4 positions double acting spool, floating circuit in 4 th position with spool in, for flow from 20 to 40 l/min.

4. Control kit *

TYPE	CODE	DESCRIPTION
13IM	5IDR207350	Double sides proportional hydraulic control with spring return in neutral position; for floating circuit spool

13IM proportional hydraulic control

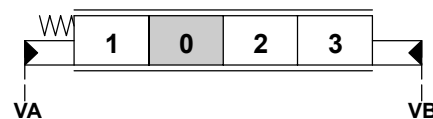
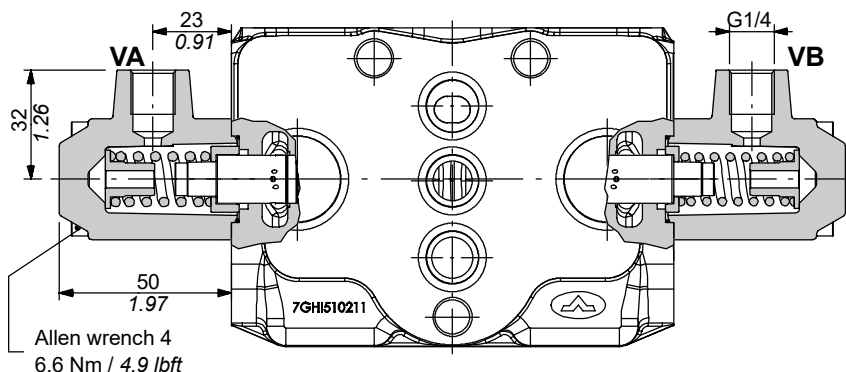

Operating features

Max pilot pressure : 70 bar / 1015 psi

Pilot pressure - stroke diagram

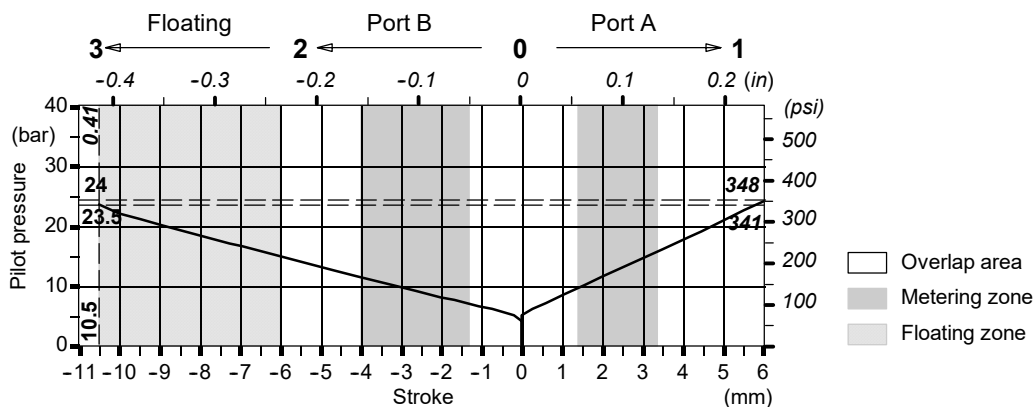

Connection example

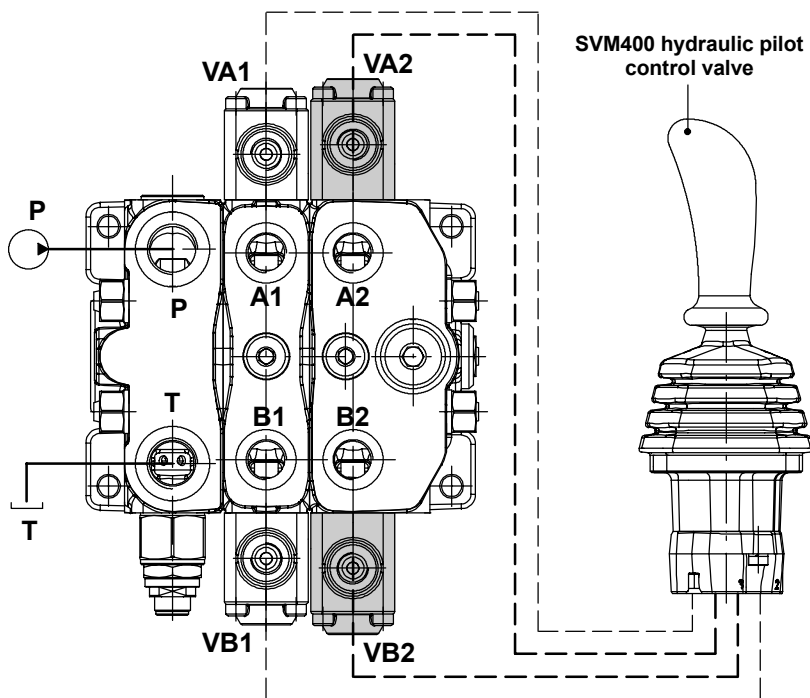

Pressure control curve (port VA2)
type 125 without step

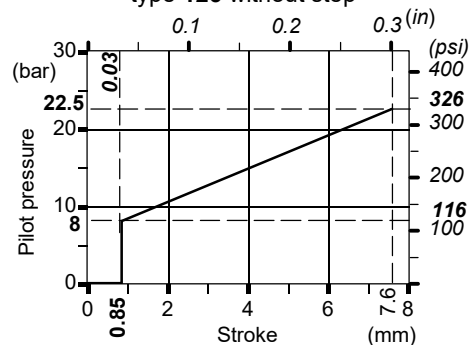

Pressure control curve (port VB2)
type 045 with step

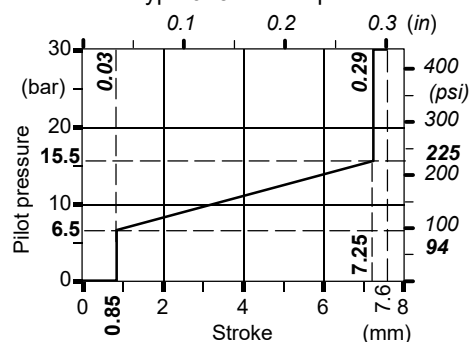

SDS100

Port valves

Antishock with prefill

U 100

Pressure setting in bar.

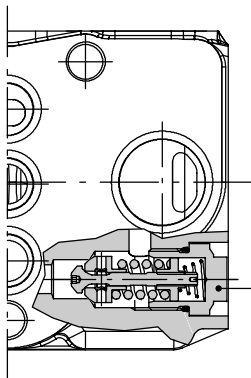

Wrench 13
24 Nm / 17.7 lbf

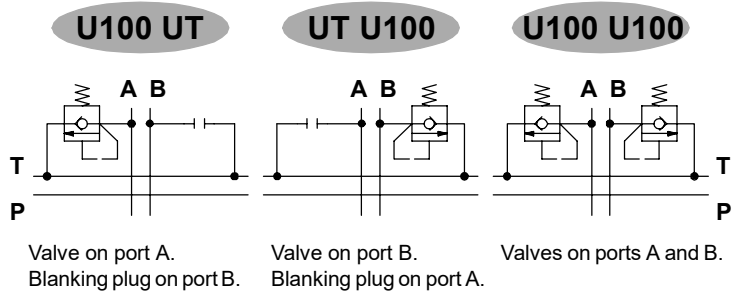

Performance data

Pressure / flow diagram

(from 25 to 140 bar / from 360 to 2050 psi)

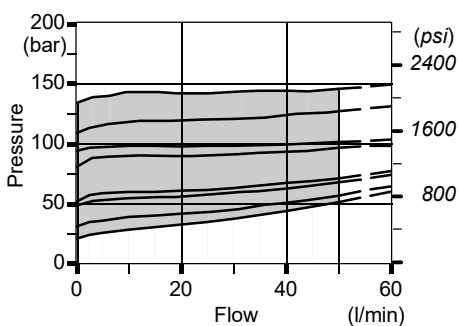

Pressure / flow diagram

(from 150 to 240 bar / from 2180 to 3500 psi)



Pressure / flow diagram

(from 250 to 340 bar / from 3600 to 4950 psi)

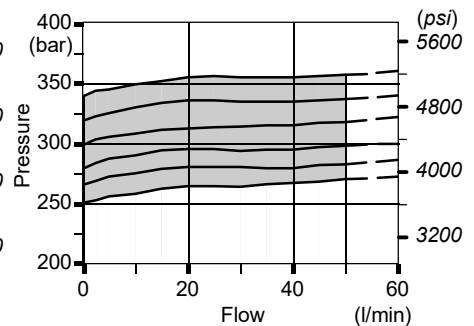

Pressure drop

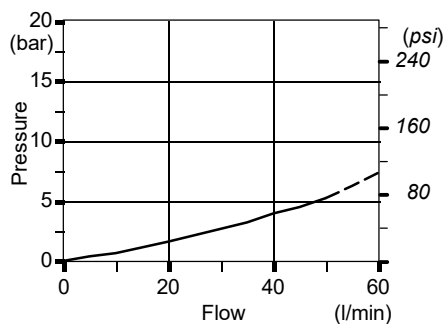

Time response

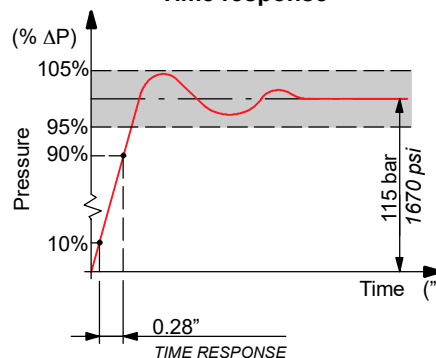

Anticavitation

C

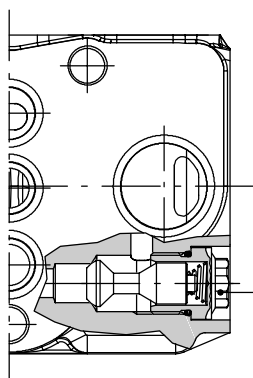

Wrench 13
24 Nm / 17.7 lbf

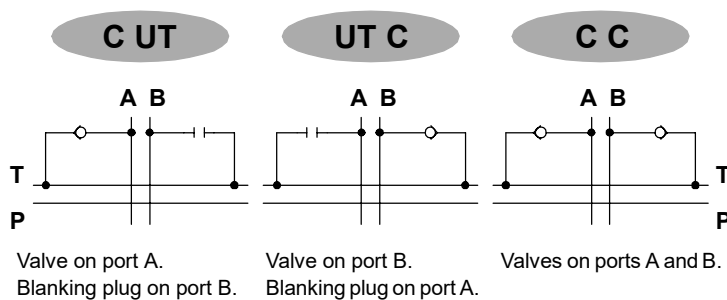

Performance data

Pressure drop

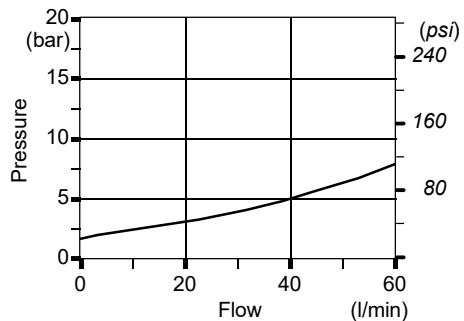

Valve blanking plug

UT

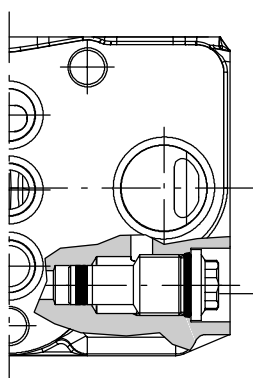

Wrench 13
24 Nm / 17.7 lbf

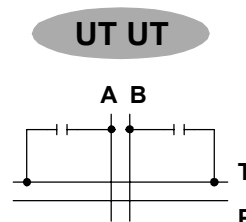

EI2 intermediate section

Section with service relief valve section and prearranged for a second inlet.

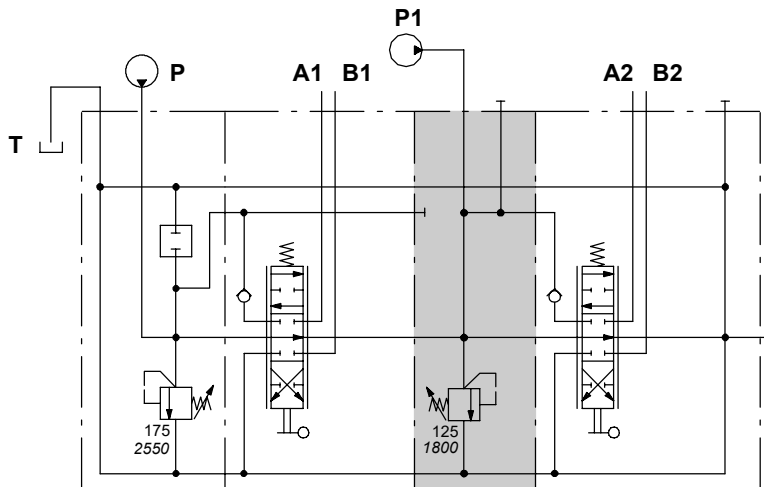
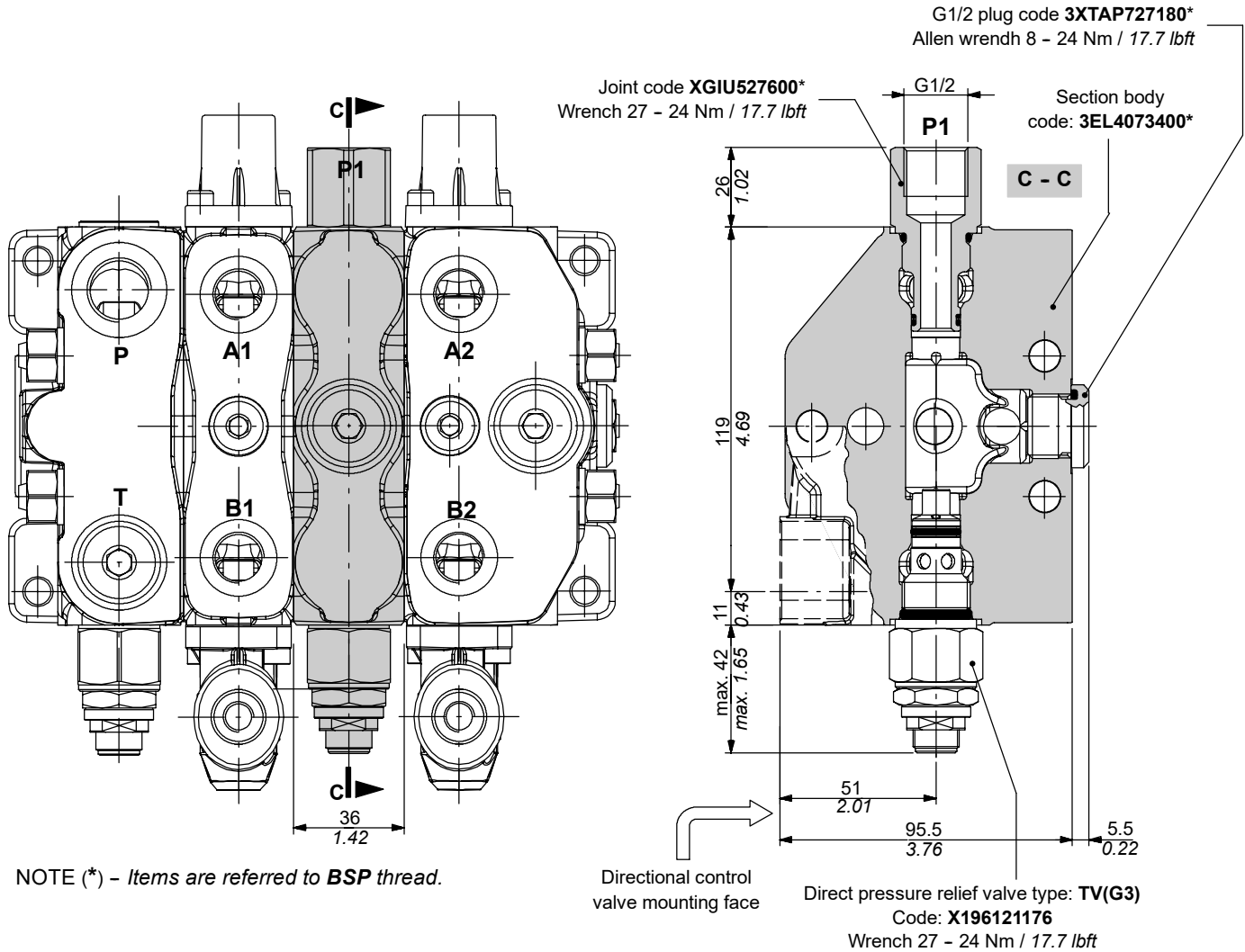

Description example:

SDS100/2/CN(TG3-175)/Q-101-8L/EI2(TVG3-125)/RQ-101-8L-F

Mid return manifold for directional valve with left and right inlet both; they allow 2 independent circuits with common outlet.

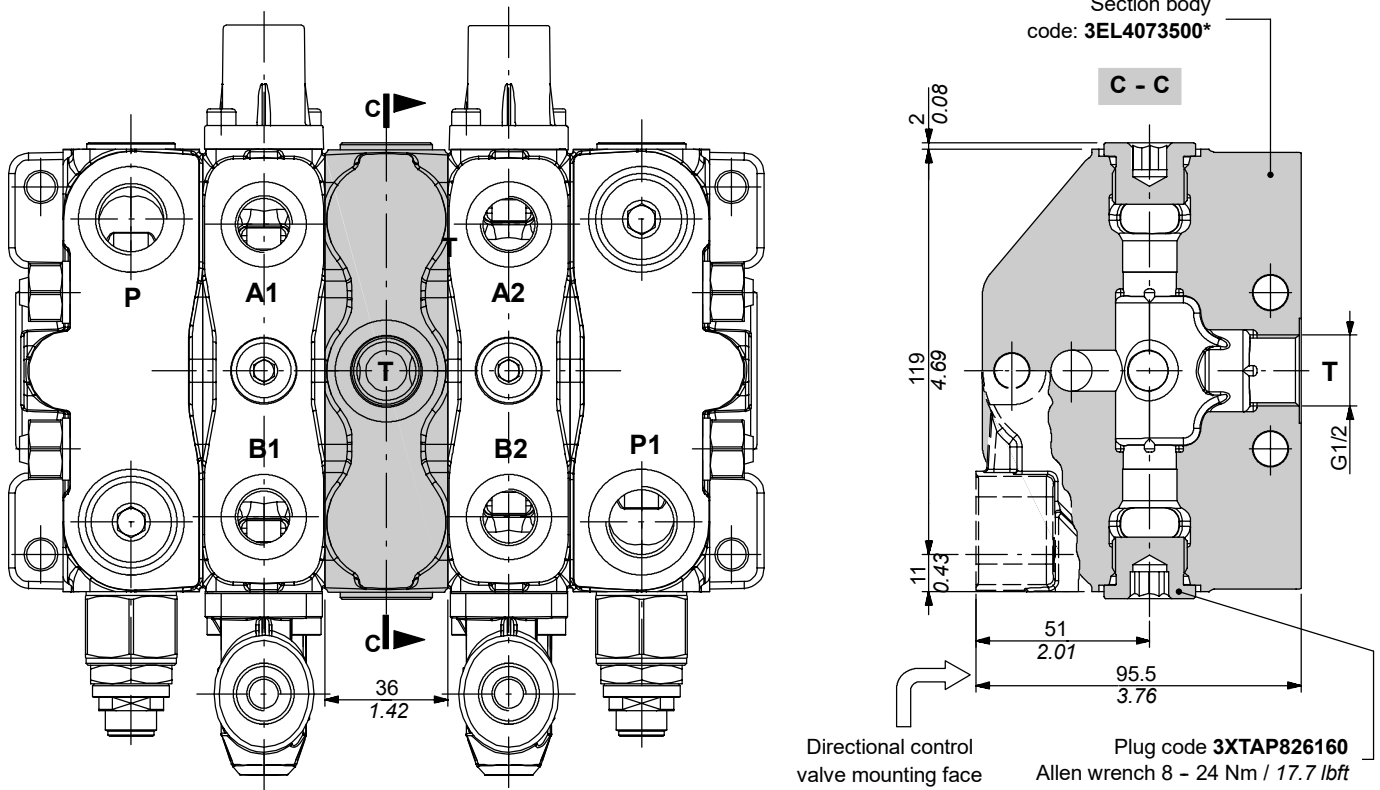

NOTE (*) - Items are referred to **BSP** thread.

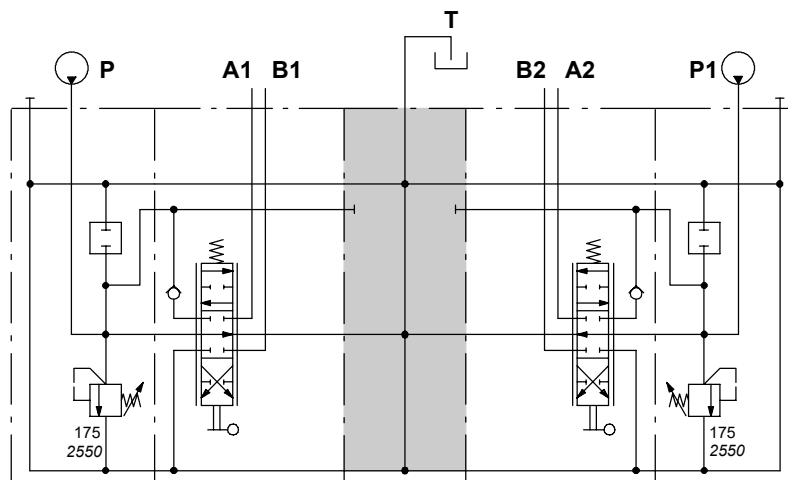

Description example:

SDS100/2/CN(TVG3-175)/Q-101-8L/CS1/Q-101-8L/BN(TVG3-175)

Section with optional outlet type R

Description example:

FS SDS100 / RQ - 101 - 8 L - AE *

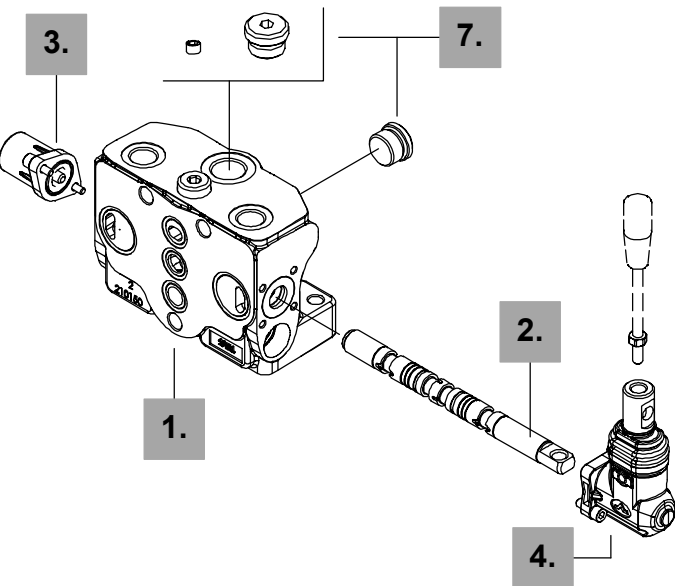
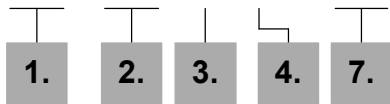

FS SDS100 / RP - I112 - 8IM . UTUT - F *

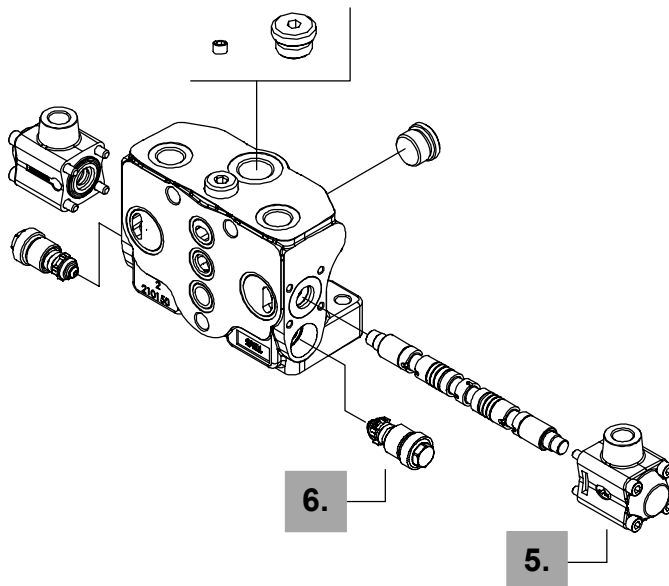
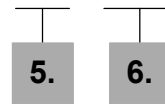

1. Working section kit page 59

Include body, seals, rings and load check valve.

TYPE	CODE	DESCRIPTION
RQ	5FIA207310	Parallel circuit
RP	5FIA207300	Parallel circuit prearranged for port valves
RQS	5FIA207319	Tandem circuit
RPS	5FIA207309	Tandem circuit prearranged for port valves

Section kits for special spools

RQ5	5FIA207315A	Parallel circuit prearranged for floating circuit: for spool type 501
RP5	5FIA207305A	As previous prearranged for port valves: for spool type 501

2. Spools page 25

For list see page 21.

3. "A" side spool positioners page 31

For list see page 21.

4. "B" side options page 41

For list see page 21.

5. Complete controls page 48

For list see page 21.

6. Port valves page 54

For list see page 21.

7. Circuit options page 61

TYPE	CODE	DESCRIPTION
F	3XTAP727180	With side and upper outlet ports plugged (standard): nr.2 plugs
TL	3XTAP727180	With side outlet ports open: nr.1 plug
TA	3XTAP727180	With upper outlet port open: nr.1 plug
AE	4TAP314010	Upper carr-over port: nr. 1 plug
AEK	3XTAP727180 + 4TAP314010	Closed centre with side outlet port open: nr.1 plug for code type

NOTA (*) - Items are referred to **BSP** thread.

Section with optional outlet type R

Section kit and hydraulic circuit

Configuration combining a working section with the closing flange to reduce dimensions.

Below it's show a configuration with parallel circuit, port valves prearrangement, optional side and upper outlet ports plugged (F type)

G1/2 ports plugged
Allen wrench 8
24 Nm / 17.7 lbf

VR load check valve
Allen wrench 6
24 Nm / 17.7 lbf

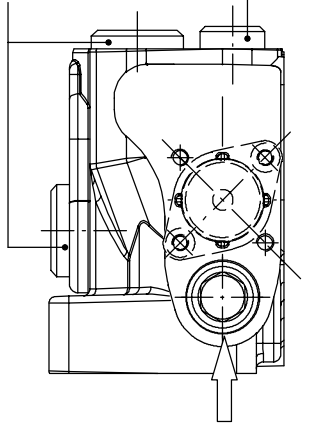

Port valves (page 54)

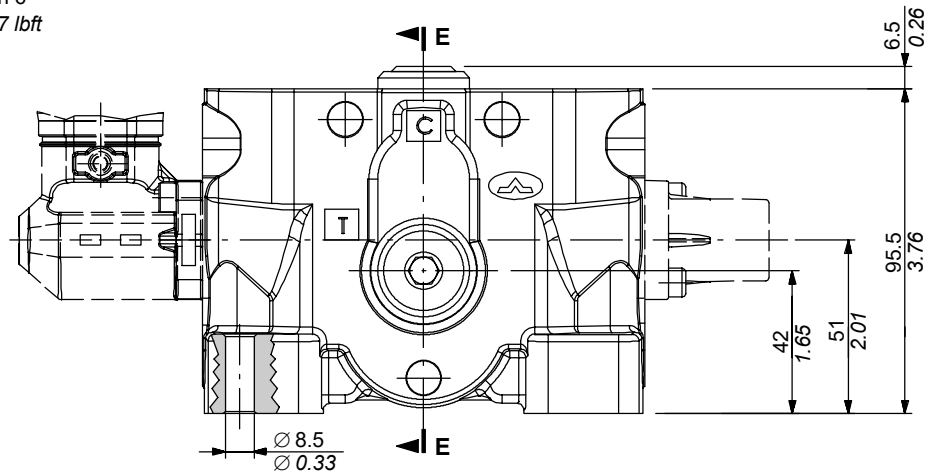

"B" side option (page 41)

"A" side spool positioner (page 31)

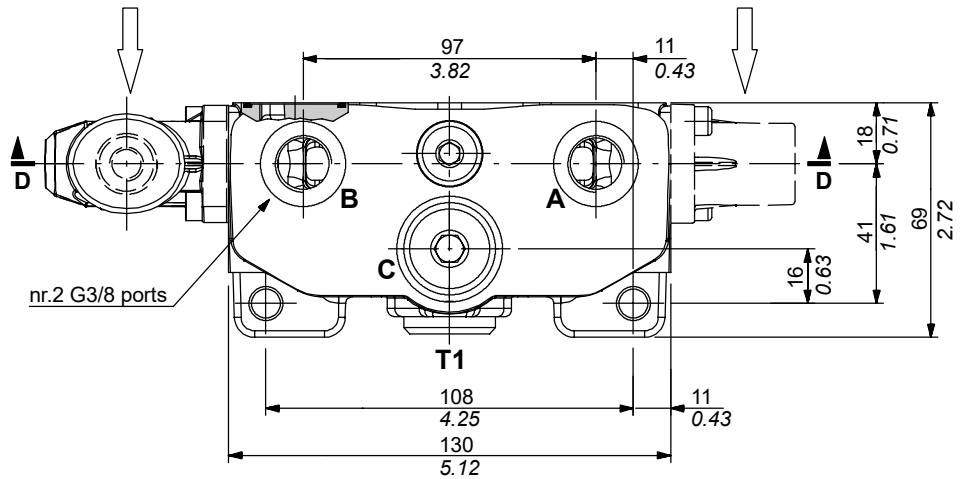

nr.2 G3/8 ports

Section with optional outlet type R

Section kit and hydraulic circuit

Parallel circuit

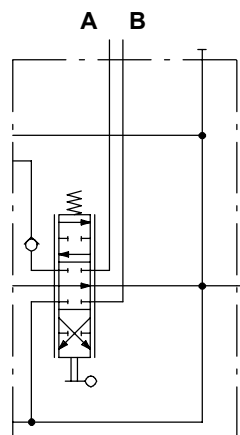
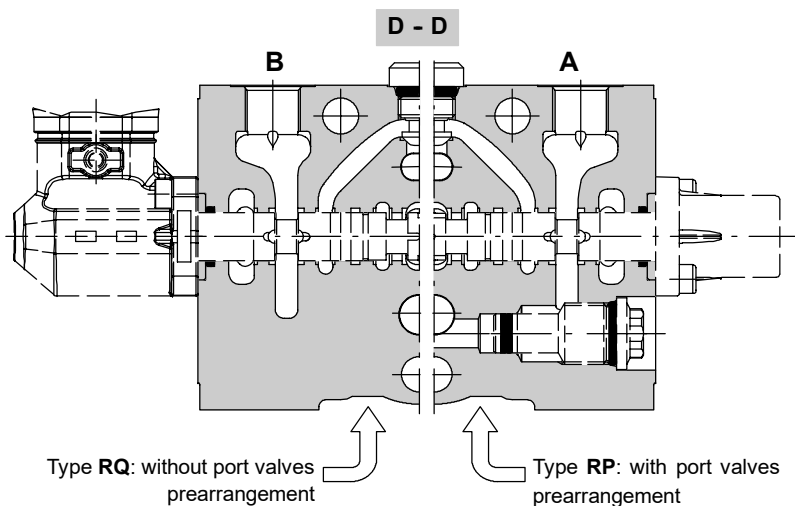

Description example:
RQ-101-8L-F

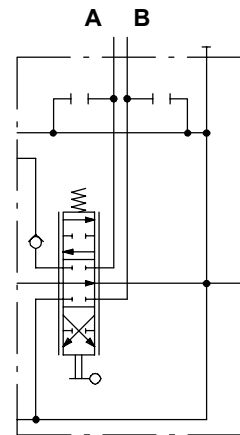

Description example:
RP-101-8L.UTUT-F

Tandem circuit

It's necessary to use QR or PR sections (see page 24).

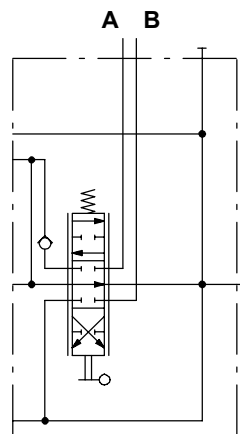
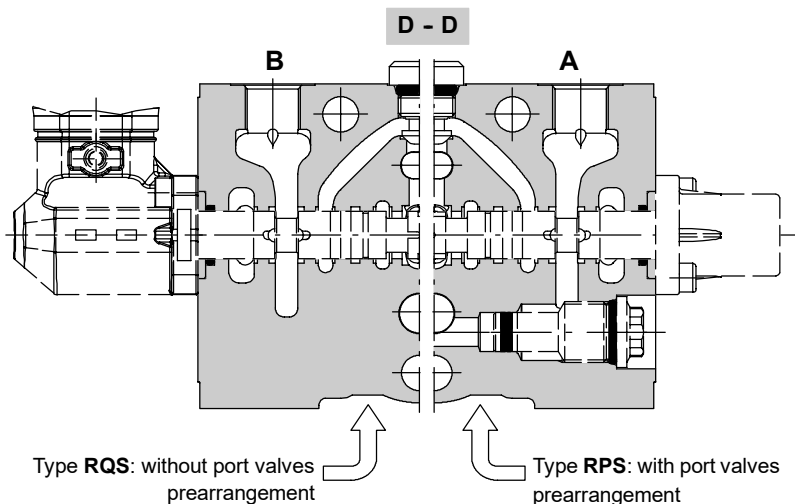

Description example:
QRS-101-8L-F

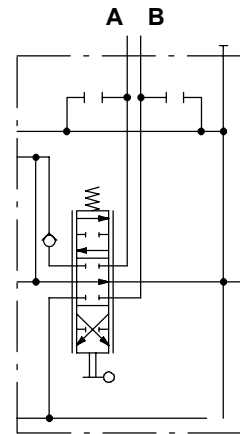

Description example:
RPS-101-8L.UTUT-F

Section with optional outlet type R

Circuit options

For type F standard configuration see page 59.

TL configuration

It's necessary to plug port T on inlet section.

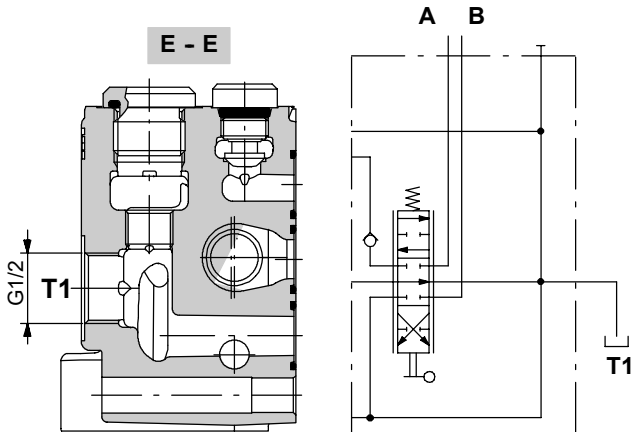

Description example:
RQ-101-8L-TL

TA configuration

It's necessary to plug port T on inlet section.

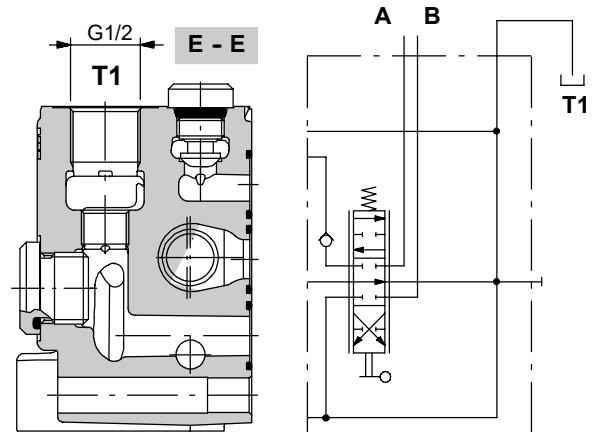

Description example:
RQ-101-8L-TA

AE configuration (carry-over)

Outlet is on port T of inlet section.

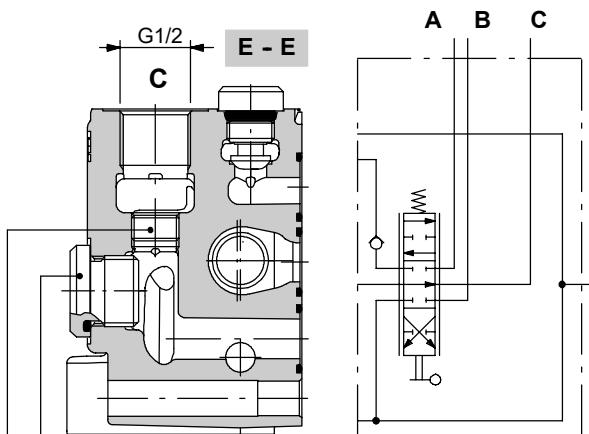

- Allen wrench 8
24 Nm / 17.7 lbft
- M14x1,5 DIN906 plug
Allen wrench 7
42 Nm / 31 lbft

Description example:
RQ-101-8L-AE

AEK configuration (closed centre)

Outlet is on port T of inlet section.

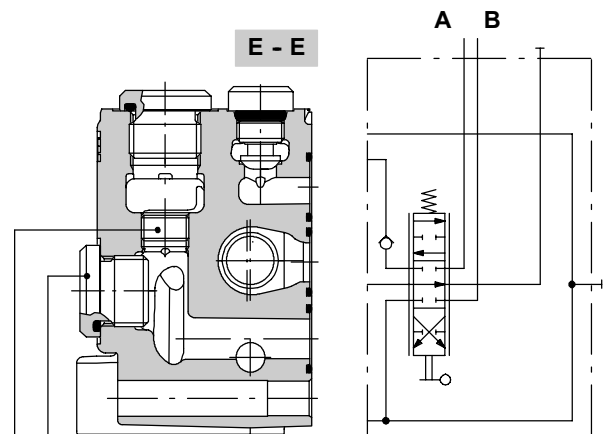

- Allen wrench 8
24 Nm / 17.7 lbft
- M14x1,5 DIN906 plug
Allen wrench 7
42 Nm / 31 lbft

Description example:
RQ-101-8L-AEK

Working sections with internal pilot and drain lines



Dimensional data 64

Hydraulic circuit 65

Ordering codes 66

Inlet and outlet section

 ordering codes 68

 section body kit and hydraulic circuit 69

 inlet relief options 17

 inlet valve options 18

E type working section

 ordering codes 72

 section body kit and hydraulic circuit 73

 spools 74

 complete controls 78

RE type working section with optional outlet

 ordering codes 84

 section body kit and hydraulic circuit 85

 circuit configuration 87

A type working section

 ordering codes 88

 section body kit and hydraulic circuit 89

RA type working section with optional outlet

 ordering codes 90

 section body kit and hydraulic circuit 91

Dimensional data

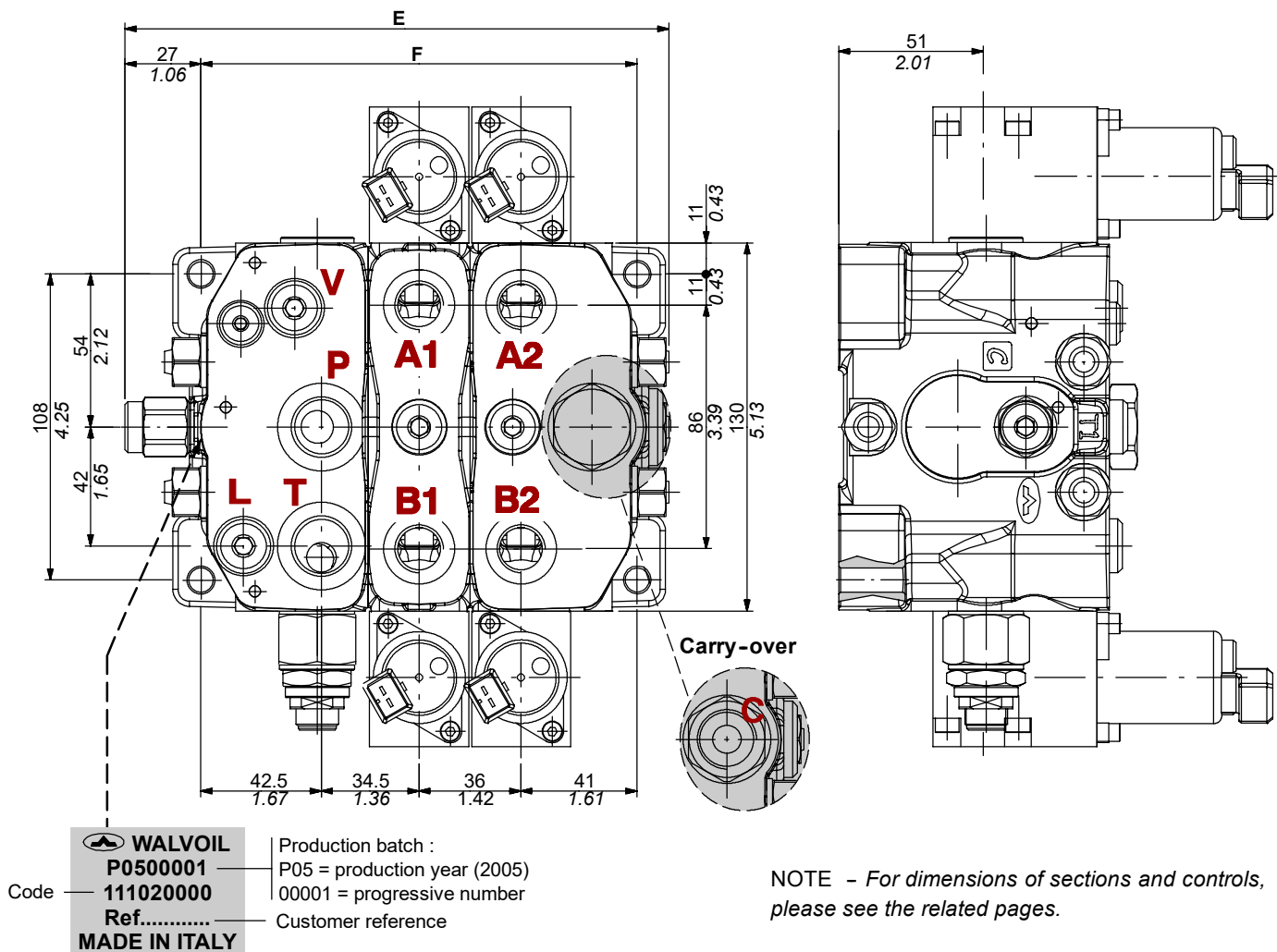

TYPE	E		F		Weight	
	mm	in	mm	in	kg	lb
SDS100/1	157	6.18	118	4.65	10.2	22.5
SDS100/2	193	7.60	154	6.06	13.8	30.4
SDS100/3	229	9.02	190	7.48	17.4	38.4
SDS100/4	265	10.43	226	8.90	21	46.3
SDS100/5	301	11.85	262	10.31	24.6	54.2

TYPE	E		F		Weight	
	mm	in	mm	in	kg	lb
SDS100/6	337	13.27	298	11.73	28.2	62.2
SDS100/7	373	14.69	334	13.15	31.8	70.1
SDS100/8	409	16.10	370	14.57	35.4	78
SDS100/9	445	17.52	406	15.98	39	86
SDS100/10	481	18.94	442	17.40	42.6	93.9

Parallel

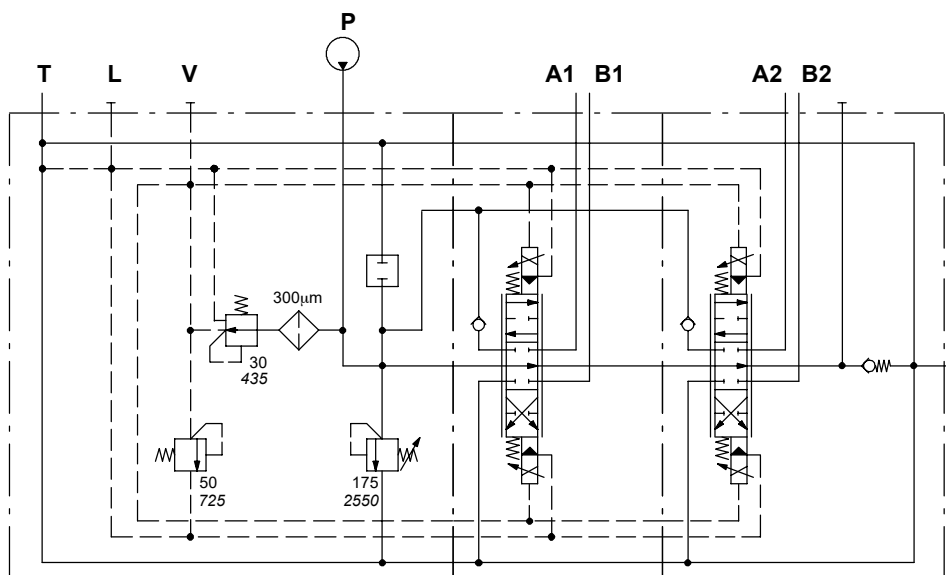

Description example:

SDS100/3/CRV(TVG3-175)/QE-E101-8EB3/RQE-E101-8EB3-VRC-F-12VDC

Tandem

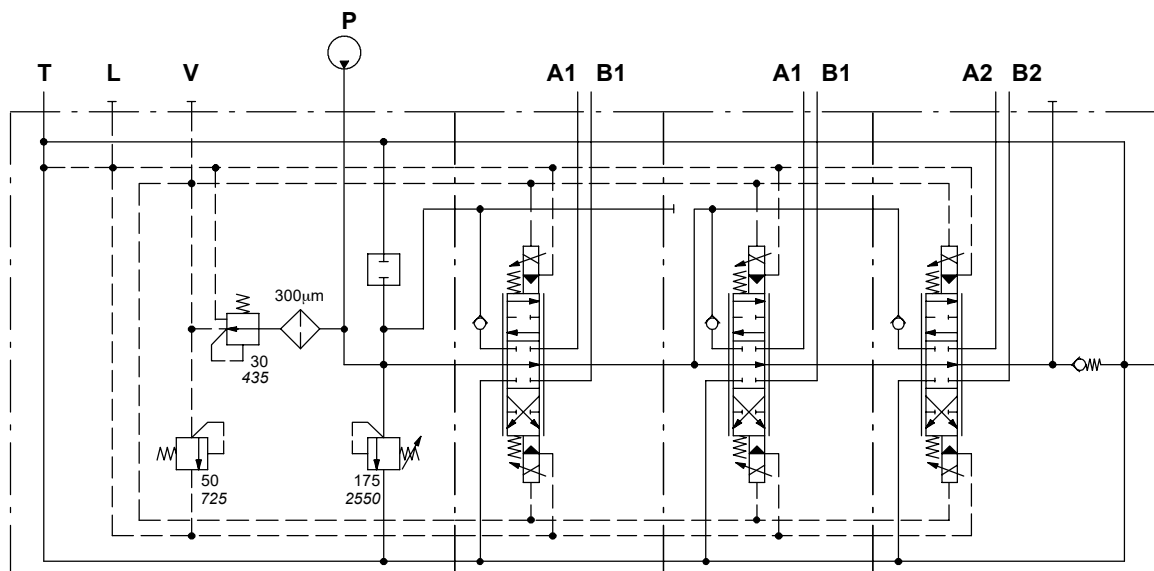

Description example:

SDS100/3/CRV(TVG3-175)/QE-E101-8EB3/SQE-E101-8EB3/RQE-E101-8EB3-VRC-F-12VDC

Ordering codes

Desription example:

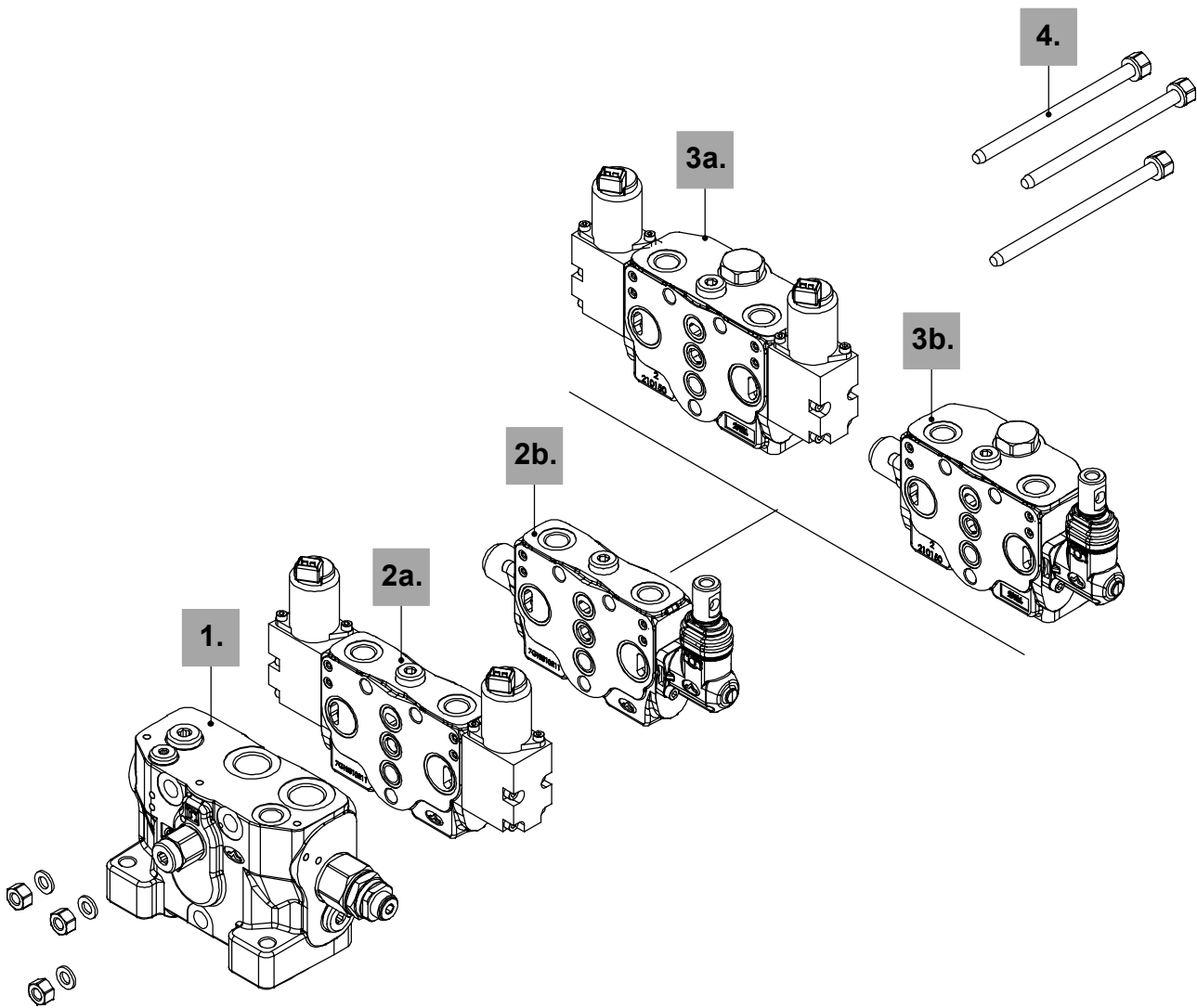
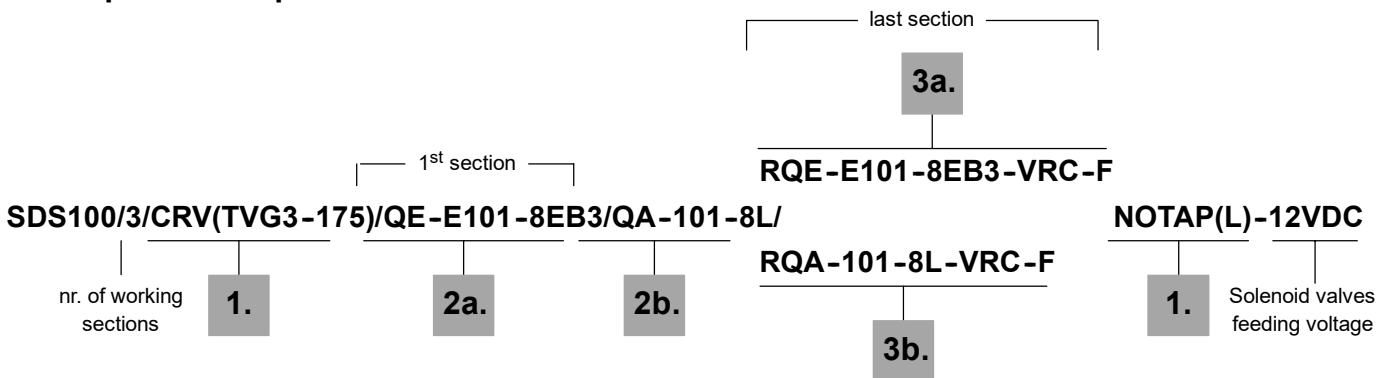

1. Complete inlet section * page 68

TYPE: **CRV(TVG3-175).....-NOTAP(L)** CODE: 610201008
 DESCRIPTION: Section with upper inlet, with pressure relief valve, with internal pilot and external drain.
 TYPE: **CRV(SV).....-NOTAP(L)** CODE: 610201009
 DESCRIPTION: As previous with pressure relief valve blanking plug

With electro-hydraulic control**2a. Complete working section type E * page 72**

TYPE: **QE-E101-8EB3-12VDC** CODE: 610151002
 DESCRIPTION: Parallel circuit with double side electro-hydraulic control
 TYPE: **PE-E101-8EB3.UTUT-12VDC** CODE: 610101006
 DESCRIPTION: Parallel circuit with double side electro-hydraulic control and port valves prearrangement
 TYPE: **SQE-E101-8EB3-12VDC** CODE: 610121006
 DESCRIPTION: Tandem circuit with double side electro-hydraulic control
 TYPE: **SPE-E101-8EB3.UTUT-12VDC** CODE: 610121007
 DESCRIPTION: Tandem circuit with double side electro-hydraulic control and port valves prearrangement

3a. Section with optional outlet type E * page 84

TYPE: **RQE-E101-8EB3-VRC-F-12VDC**
 CODE: 610351006
 DESCRIPTION: Parallel circuit with double side electrihydraulic control and backpressure valve
 TYPE: **RPE-E101-8EB3.UTUT-VRC-F-12VDC**
 CODE: 610301006
 DESCRIPTION: As previous with port valves prearrangement

With mechanical controls**2b. Complete working section type A * page 88**

TYPE: **QA-101-8L** CODE: 610153001
 DESCRIPTION: Parallel circuit with lever control and spring return in neutral position
 TYPE: **PA-101-8L.UTUT** CODE: 610103001
 DESCRIPTION: Parallel circuit with lever control and spring return in neutral position, prearranged for port valves
 TYPE: **SQA-101-8L** CODE: 610121010
 DESCRIPTION: Tandem circuit with lever control and spring return in neutral position
 TYPE: **SPA-101-8L.UTUT** CODE: 610121011
 DESCRIPTION: Tandem circuit with lever control and spring return in neutral position, prearranged for port valves

3b. Section with optional outlet type A * page 90

TYPE: **RQA-101-8L-VRC-F** CODE: 610301008
 DESCRIPTION: Parallel circuit with lever control and spring return in neutral position and backpressure valve
 TYPE: **RPA-101-8L.UTUT-VRC-F** CODE: 610301009
 DESCRIPTION: As previous with port valves prearrangement

4. Assembling kit

CODE	DIRECTIONAL VALVE
5TIR110145	Tie rod kit for 1 section valve
5TIR110179	Tie rod kit for 2 sections valve
5TIR110215	Tie rod kit for 3 sections valve
5TIR110252	Tie rod kit for 4 sections valve
5TIR110289	Tie rod kit for 5 sections valve
5TIR110323	Tie rod kit for 6 sections valve
5TIR110359	Tie rod kit for 7 sections valve
5TIR110397	Tie rod kit for 8 sections valve
5TIR110431	Tie rod kit for 9 sections valve
5TIR110467	Tie rod kit for 10 sections valve

NOTE (*) - Codes are referred to **BSP** thread.

Inlet and outlet section

Description example:

FE SDS100 / C RV (TVG3 - 175) ELT-12VDC - NOTAP(L) *

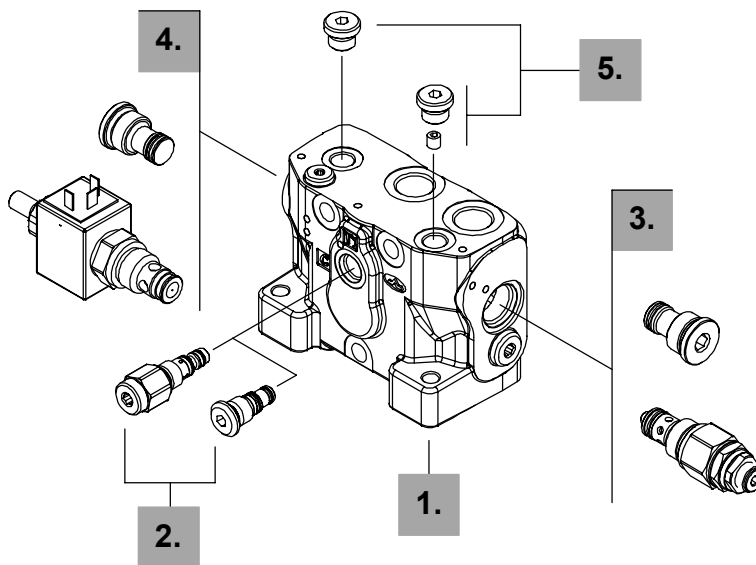
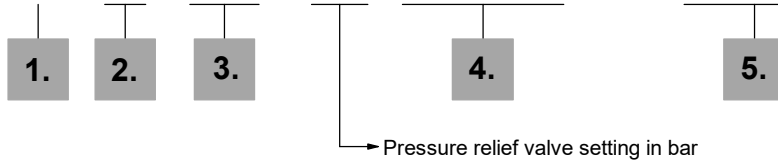

1. Section body kit * page 69

TYPE	CODE	DESCRIPTION
C	5FIA107305	Standard configuration fitted with relief valve VLP

2. Pressure reducing valve page 69

TYPE	CODE	DESCRIPTION
RV	X219740030	With pressure reducing valve VRPF
SRV	XTAP519350	With valve blanking plug

3. Inlet relief options page 17

Standard setting is referred to 10 l/min flow.

TYPE	CODE	DESCRIPTION
<u>VMD100/1: direct pressure relief valve type T (standard)</u>		
(TVG2-80)	X196121081	Range 63 to 100 bar / 900 to 1450 psi standard setting 80 bar / 1160 psi
(TVG3-175)	X196121176	Range 100 to 200 bar / 1450 to 2900 psi standard setting 175 bar / 2550 psi
(TVG4-220)	X196121220	Range 200 to 300 bar / 2900 to 4350 psi standard setting 220 bar / 3200 psi

SV XTAP526360 Pressure relief valve blanking plug

4. Inlet valve options page 18

TYPE	CODE	DESCRIPTION
ELT	5CAR407320	12 VDC solenoid operated unloader valve
	5CAR407325	24 VDC solenoid operated unloader valve
SV	XTAP526360	Valve blanking plug: in valve description the word SV must be omitted because standard

5. Pilot and drain* page 69

TYPE	CODE	DESCRIPTION
TAP(VL)	3XTAP719150	Internal pilot and drain: needs two G1/4 plugs
NOTAP(L)	3XTAP719150+4TAP308006	Internal pilot and external drain: needs G1/4 plug and M8x1 tapered plug
NOTAP(V)	3XTAP719150	External pilot and internal drain: needs G1/4 plug
NOTAP(VL)	4TAP308006	External pilot and drain: needs M8x1 tapered plug

NOTE (*) - Codes are referred to **BSP** thread.

Section kit and hydraulic circuit

It's show a configuration with internal pilot and drain.

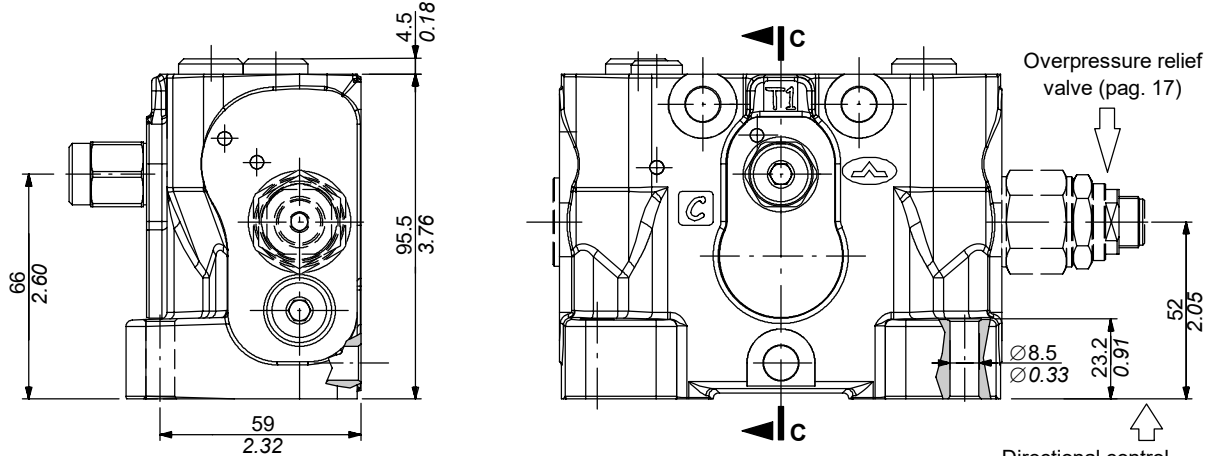

Pressure reducing valve **VRPF**
Wrench 19 - 42 Nm / 31 lbft

Relief valve **VLP**
Allen wrench 4
6.6 Nm / 4.9 lbft

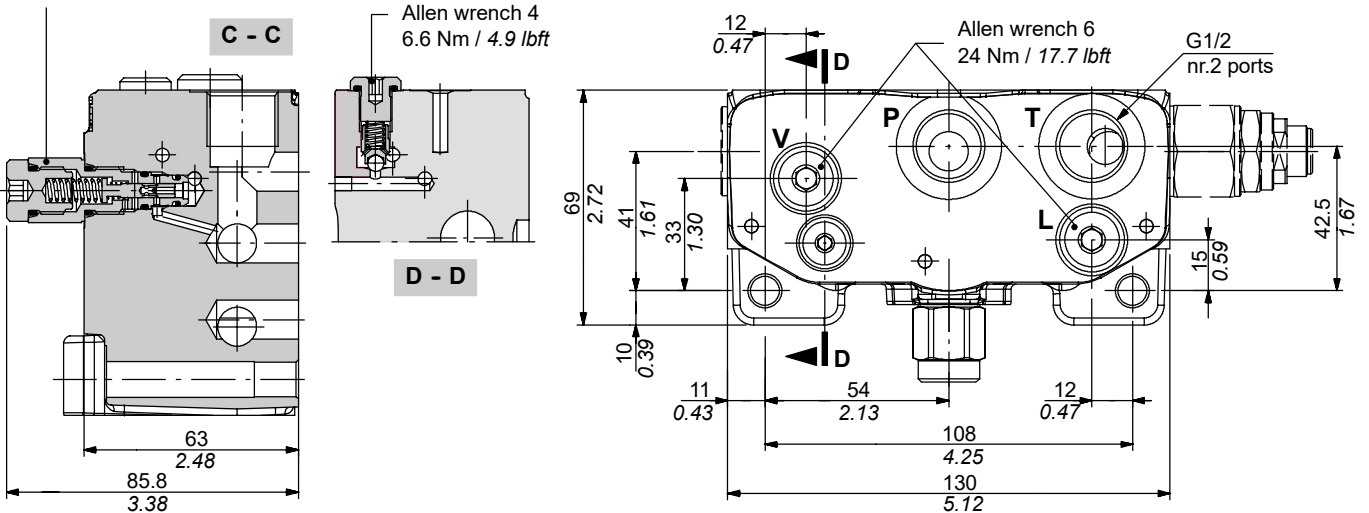

VRP pressure reducing valve
performance curve
(internal drain)

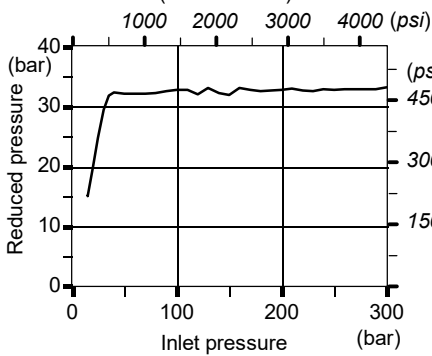

VLP relief valve
performance curve

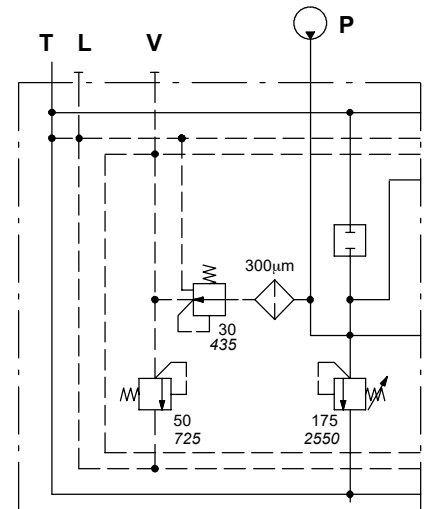
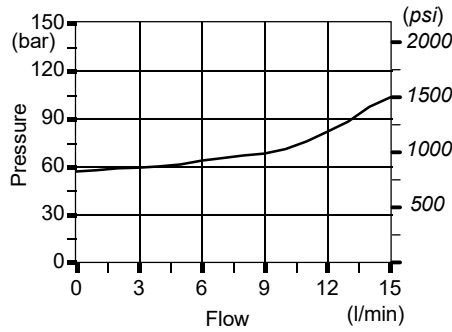

Description example:
CRV(TVG3-175)....- TAP(VL)

Inlet and outlet section

Section kit and hydraulic circuit

External drain configuration

Suggested configuration for valve with **8EB3LH** electro-hydraulic control: required to avoid that backpressure on return can influence the hysteresis of the control.

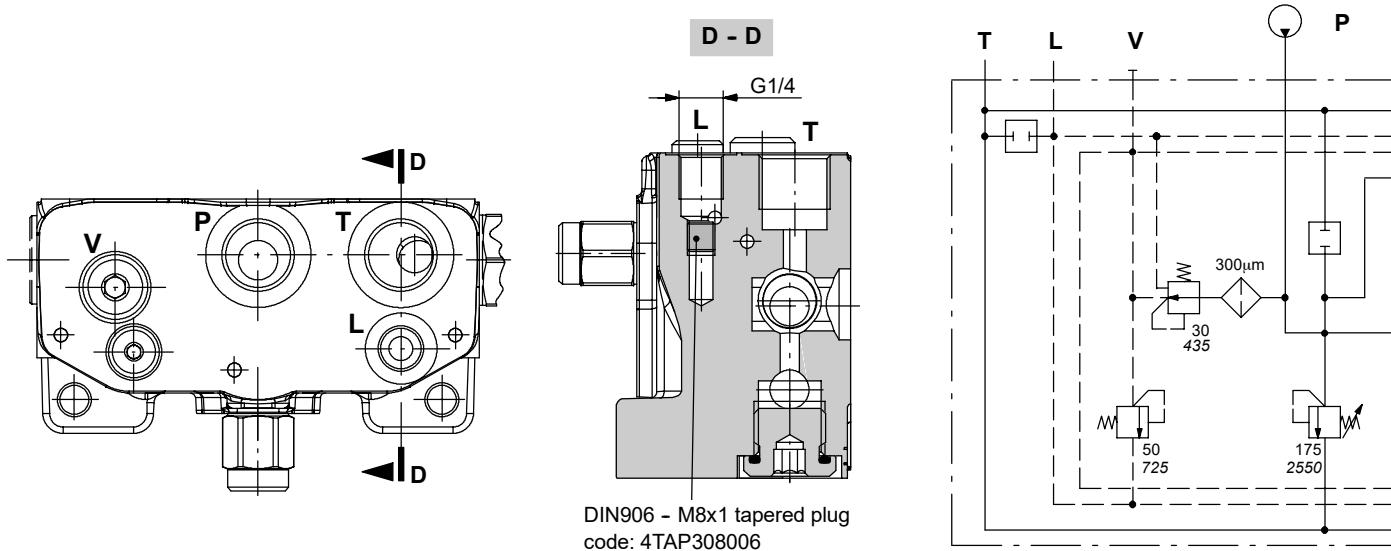

Description example:
CRV(TVG3-175)....- **NOTAP(L)**

External pilot and drain configuration

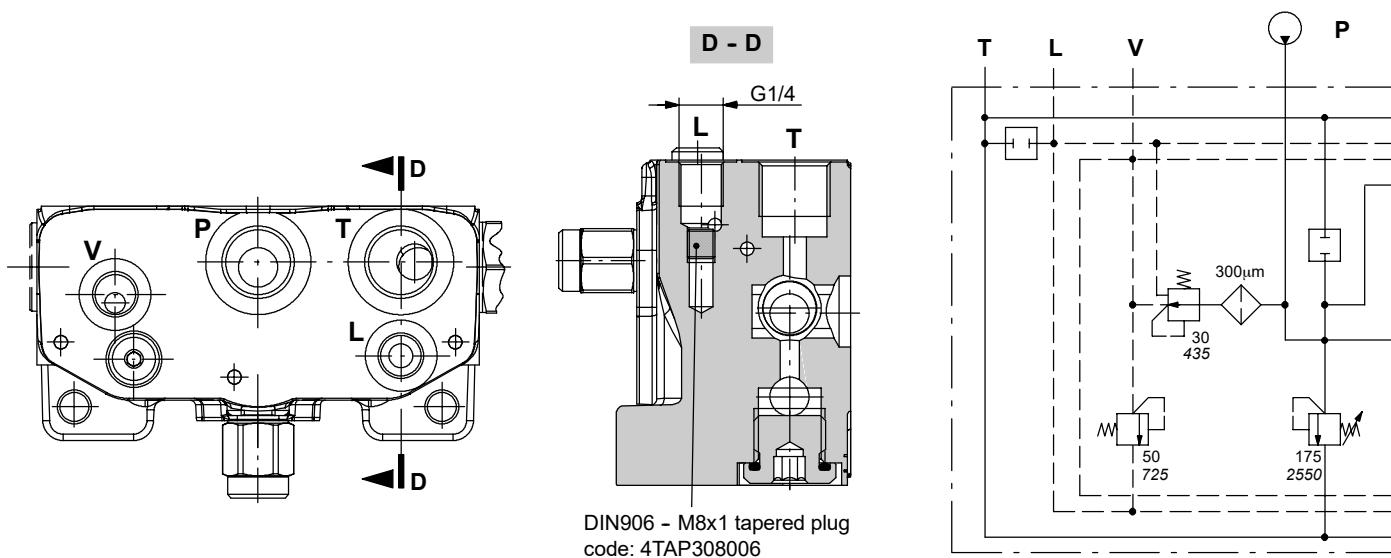

Description example:
CRV(TVG3-175)....- **NOTAP(VL)**

Section kit and hydraulic circuit

Configuration without pressure reducing valve

The electro-hydraulic control kit can be driven by connecting a pump (Q= 5 l/min and Pmax= 50 bar / 725 psi) to the V port and replacing the pressure reducing valve with the appropriate plug (see page 69).

Available with internal or external drain.

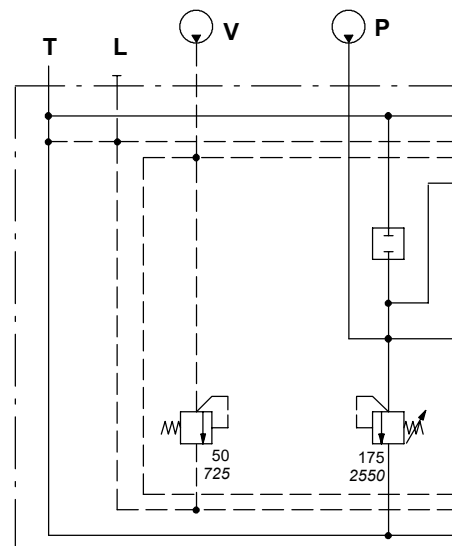
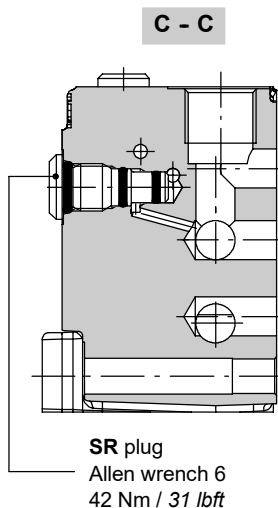
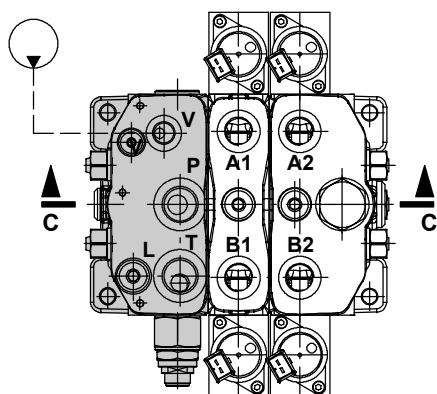

Description example:
CSR(V)TVG3-175)....- NOTAP(V)

Working section type E

Description example:

EL SDS100 / PE - E101 - 8EB3 . U100U100 - 12VDC *

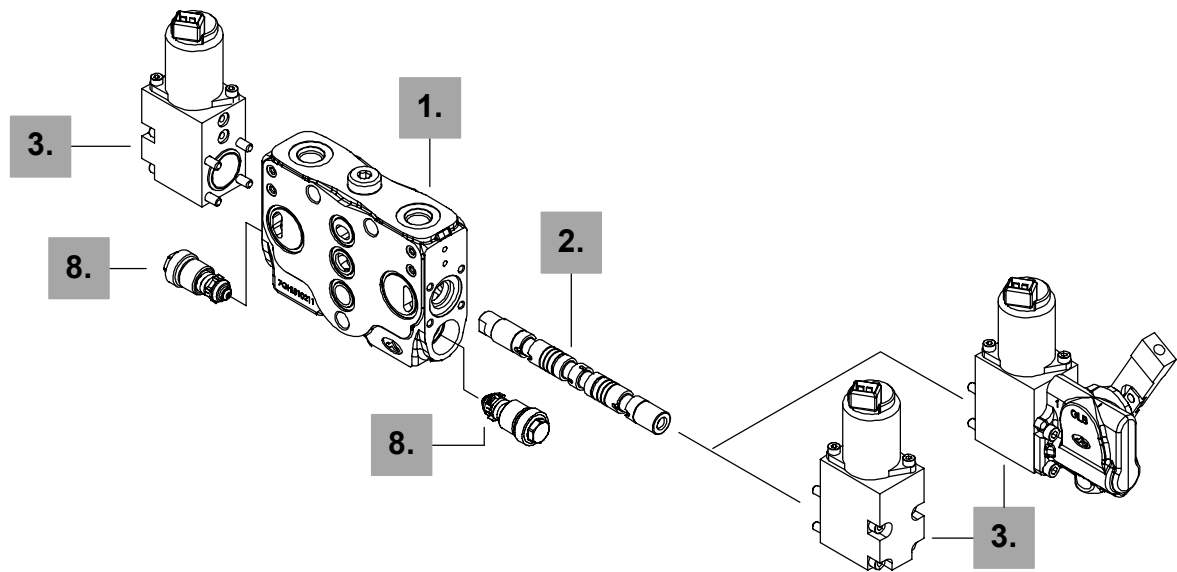
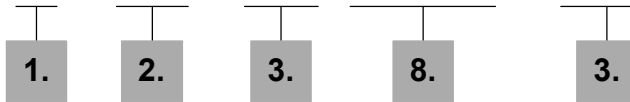

1. Working sections kit * page 73

Include body, seals and load check valve.

TYPE	CODE	DESCRIPTION
QE	5EL1073012	Parallel circuit without port valves prearrangement
PE	5EL1073002	Parallel circuit with port valves prearrangement
SQE	5EL3073012	Tandem circuit without port valves prearrangement
SPE	5EL3073002	Tandem circuit with port valves prearrangement

2. Spools page 74

If not specified otherwise, the spool are from 20 to 40 l/min flow

TYPE	CODE	DESCRIPTION
E102	3CU6710102	Double acting, 3 positions, with A and B closed in neutral position; for flow up to 20 l/min
E101	3CU6710000	As previous, from 20 to 40 l/min flow
E103	3CU6710103	As previous, from 40 to 60 l/min flow
E201	3CU6725000	Double acting, 3 positions, with A and B open to tank in neutral position
E301	3CU6731000	Single acting in A, 3 positions, B plugged: needs G3/8 plug

Specials spools for particular positioners kit pag. 77

E501	3CU6752501	Double acting, 4 positions, floating in 4 th positions with spool in
-------------	------------	---

3. Electro-hydraulic controls page 78

TYPE	CODE	DESCRIPTION
8EB3	5IDR907312	12VDC double side proportional type with spring return to neutral position
	5IDR907324	As previous 24VDC
8EB3LH	5IDR907612	12VDC double side proportional type with spring return to neutral position and wet-type lever control
	5IDR907624	As previous 24VDC
<u>Particular positioners kit for special spools page 78</u>		
TYPE	CODE	DESCRIPTION
13EB3	5IDR917312	AS type 8EB3, 12VDC: for spool type E501
	5IDR917324	As previous 24VDC
13EB3LH	5IDR917712	AS type 8EB3LH, 12VDC: for spool type E501
	5IDR917724	As previous 24VDC

8. Port valves page 54

Fixed setting antishock with prefill valves.

NOTE (*) - Codes are referred to **BSP** thread.

Section kit and hydraulic circuit

It can be supplied with parallel or tandem circuit; series circuit is obtained as related to page 10.
All sections are available with or without valves prearrangement

Parallel circuit

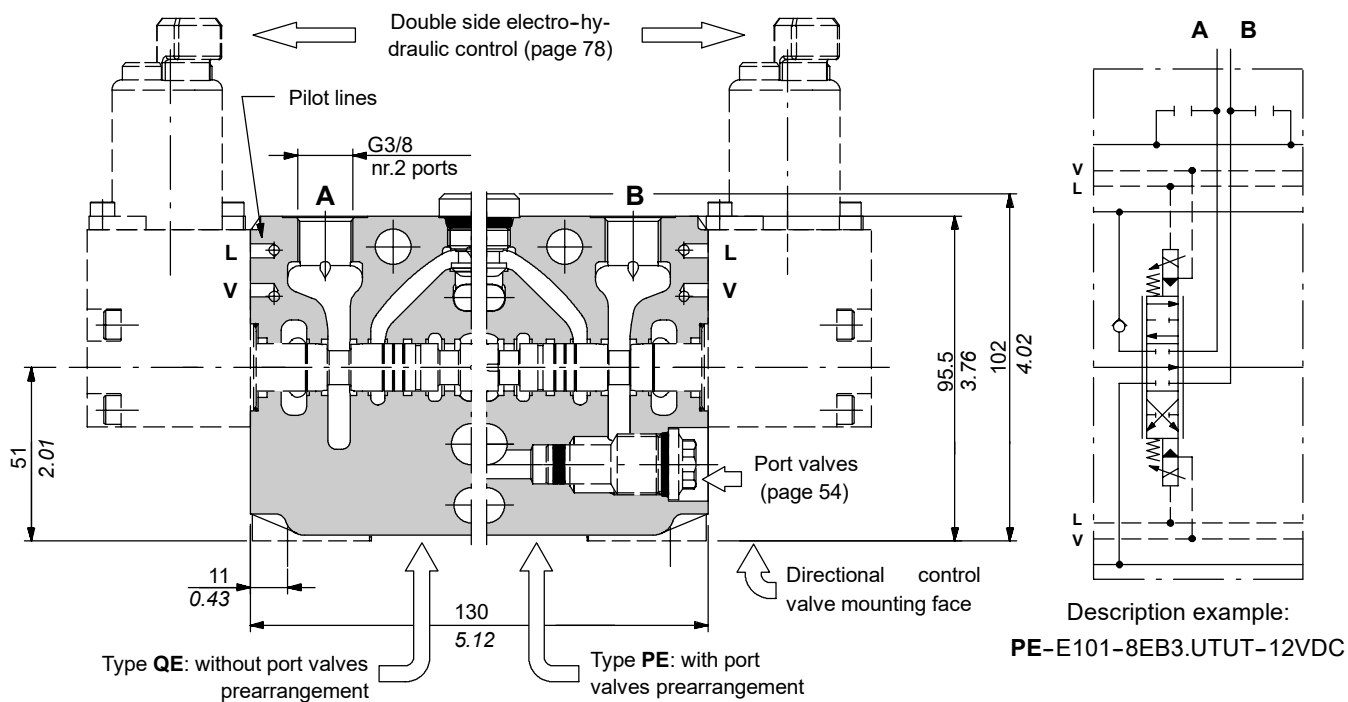

Tandem circuit

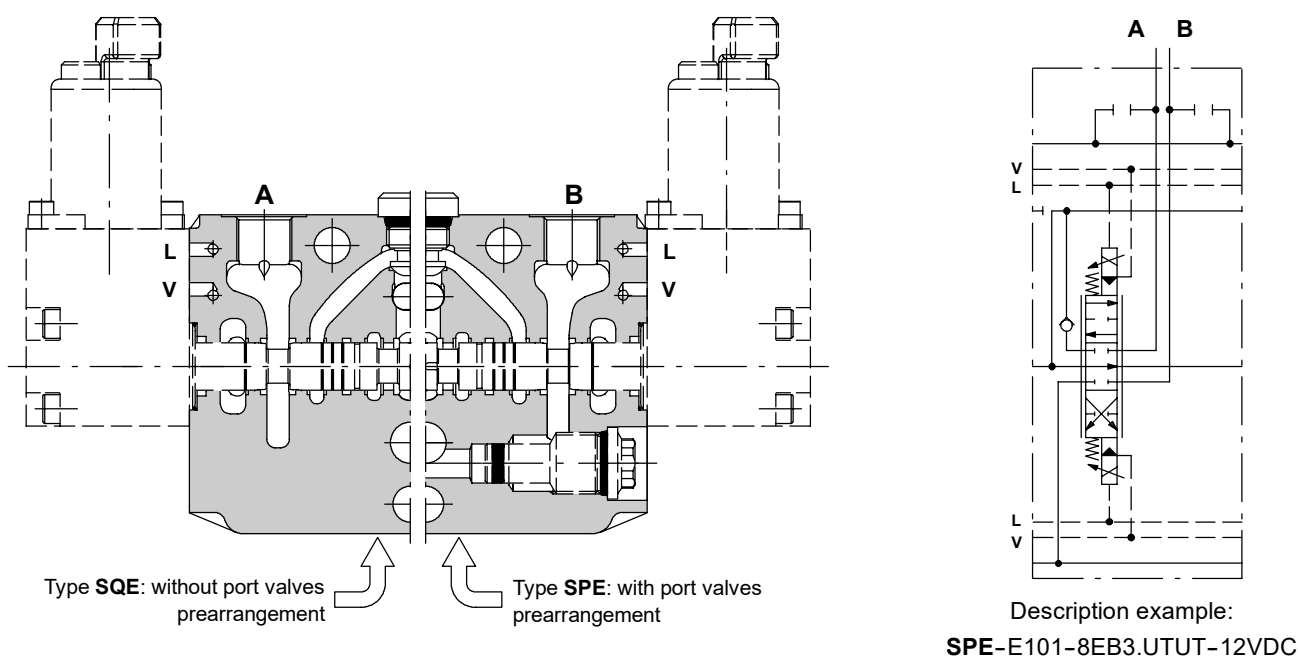

Working section type E

Spools

Type E101

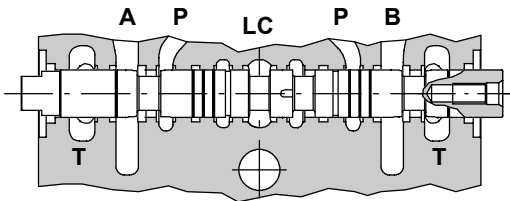

P → A B → T

▶ stroke + 6.5 mm
+ 0.26 in

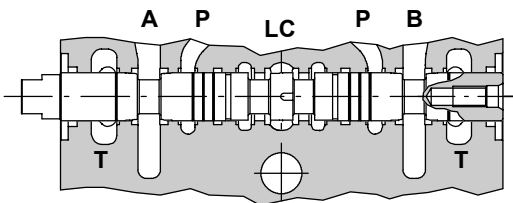
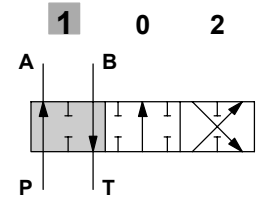

P-A-B-T closed, with flow through line (LC) open

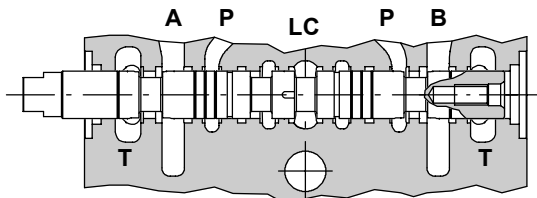
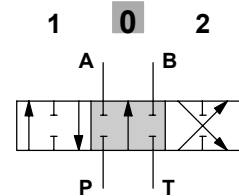

P → B A → T

◀ stroke - 6.5 mm
- 0.26 in

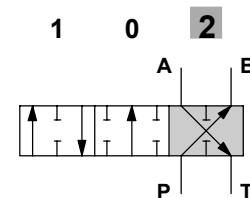

Spool metering P → A(B)

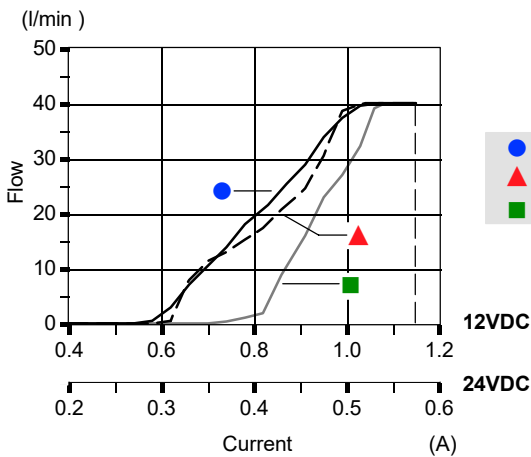

Q_{in} = 40 l/min

- P_(on ports) = 63 bar / 900 psi
- ▲ P_(on ports) = 100 bar / 1450 psi
- P_(on ports) = 250 bar / 2900 psi

Spool metering A(B) → T

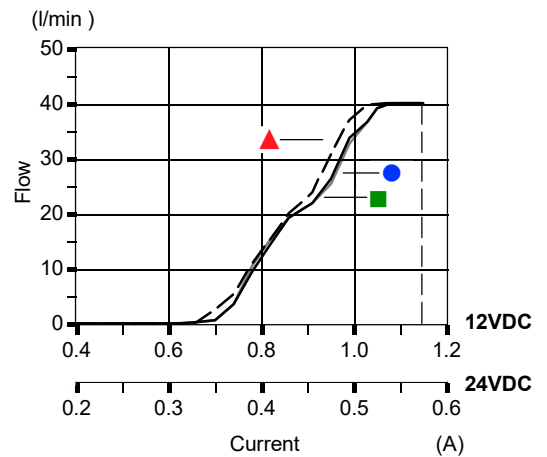

Spools

Type E102

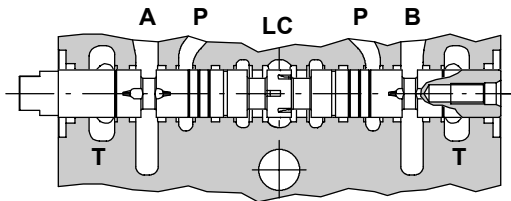

+ 6.5 mm / + 0.26 in
 (1) ▶
 ◀ ▶ (0)
 ◀ (2)
 - 6.5 mm / - 0.26 in

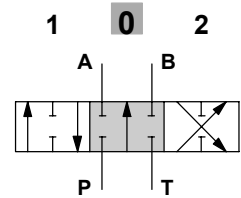

P-A-B-T closed, with flow through line (LC) open

Spool metering P→A(B)

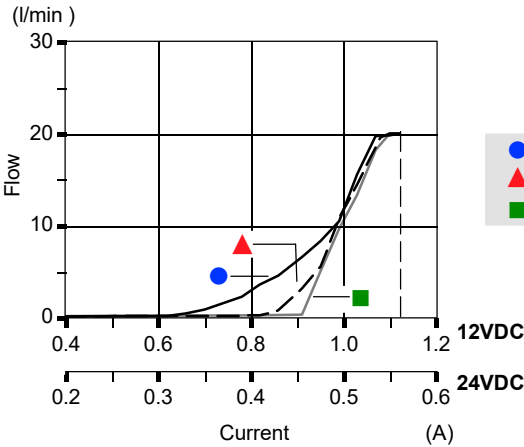

Spool metering A(B)→T

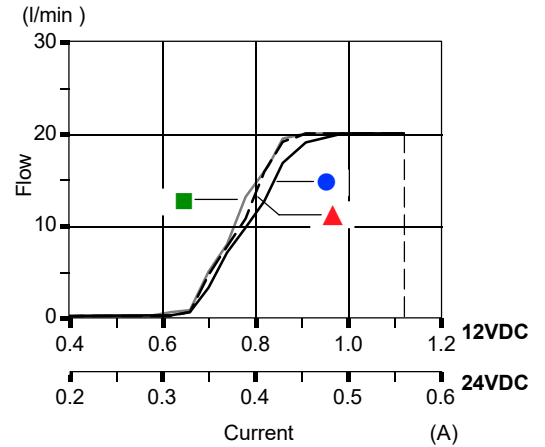

Type E103

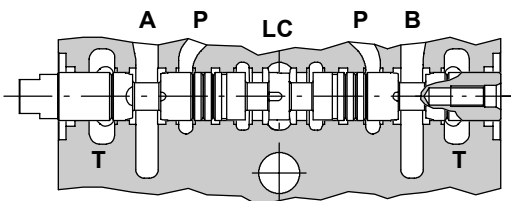

+ 6.5 mm / + 0.26 in
 (1) ▶
 ◀ ▶ (0)
 ◀ (2)
 - 6.5 mm / - 0.26 in

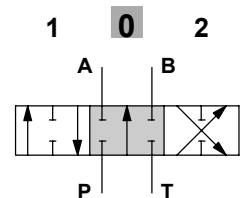

P-A-B-T closed, with flow through line (LC) open

Spool metering P→A(B)

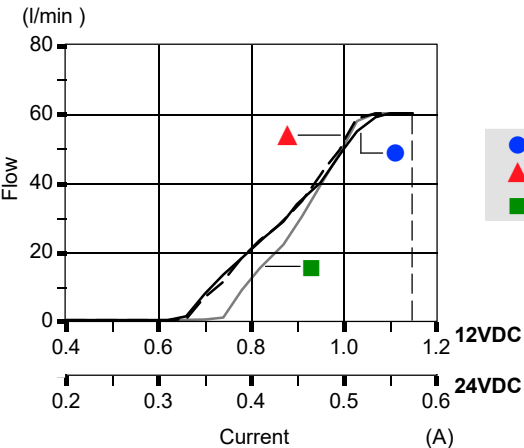

Spool metering A(B)→T

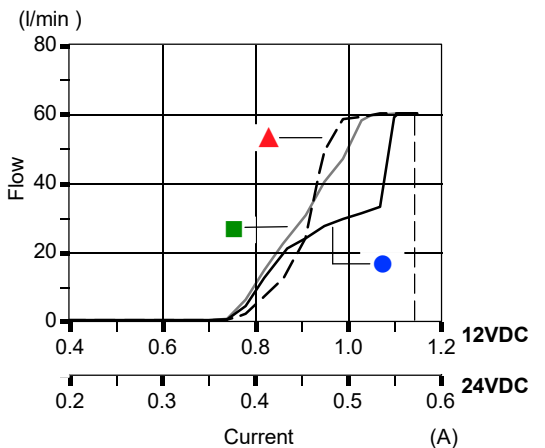

Working section type E

Spools

Type E201

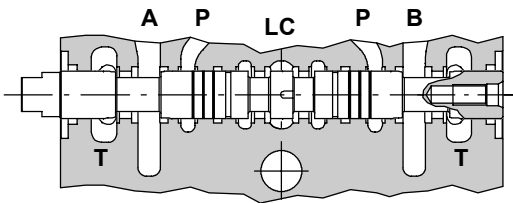

+ 6.5 mm / + 0.26 in
(1) ▶
 ◀ ▶ **(0)**
 ◀ **(2)**
 - 6.5 mm / - 0.26 in

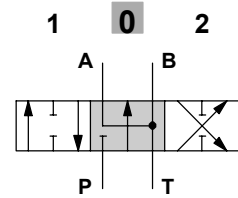

P closed, A-B to Tank, with flow through line (LC) open

Type E301

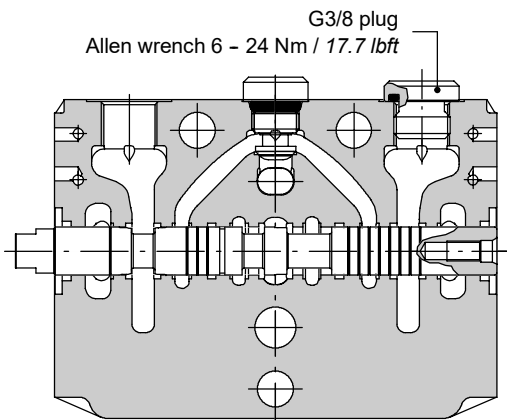

+ 6.5 mm / + 0.26 in
(1) ▶
 ◀ ▶ **(0)**
 ◀ **(2)**
 - 6.5 mm / - 0.26 in

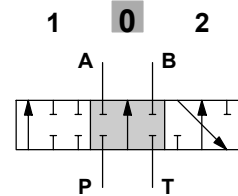

P-A-B-T closed, with flow through line (LC) open

Spools

Type E501

QE5 - PE5 section or RQE5 - RPE5 optional outlet section required, contact Sales Dpt. for further information.

To be combined with 13EB3 (see page 78) or 13EB3LH (see page 82) electrohydraulic controls.

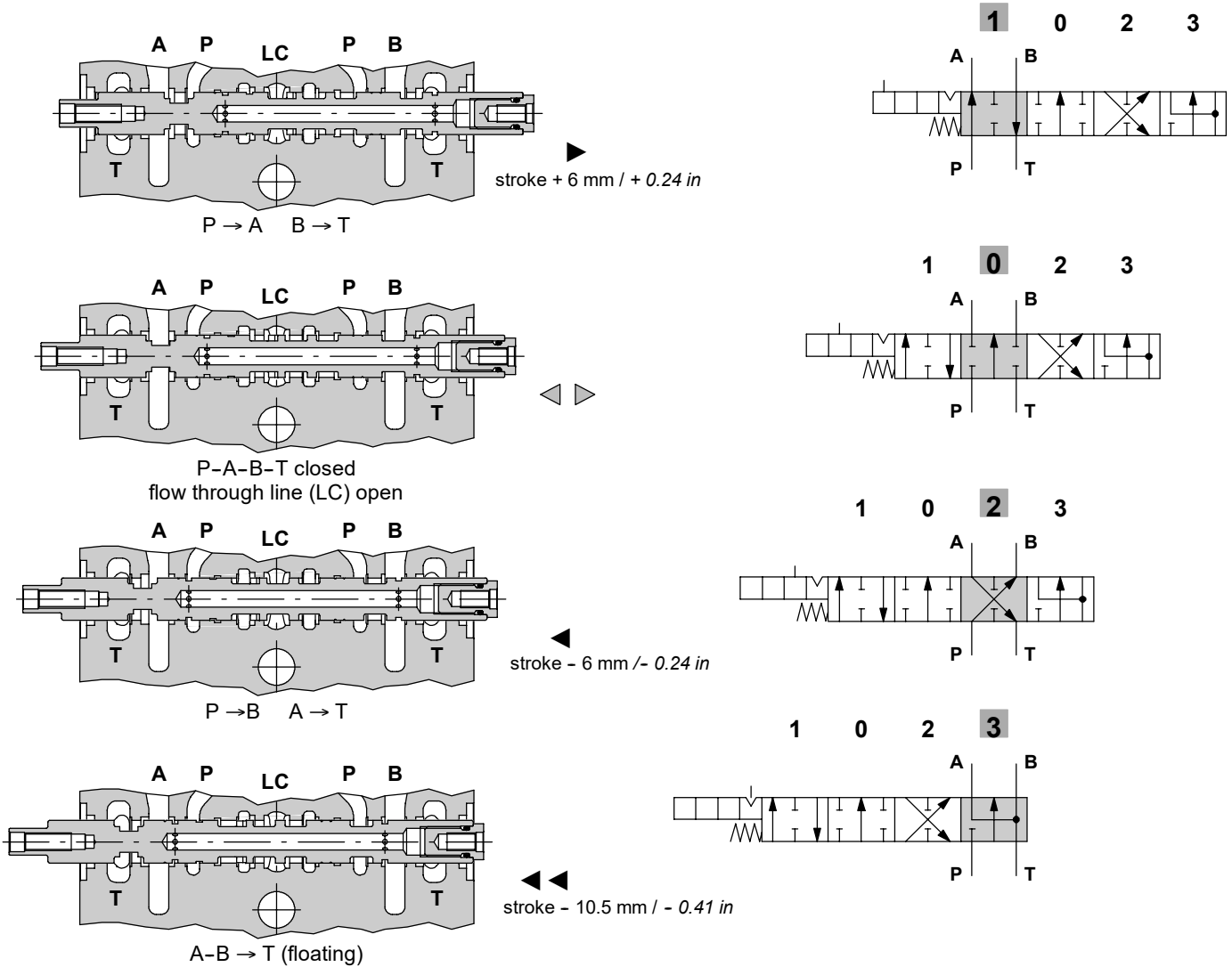

Spool metering

Q_{in} = 40 l/min / P_(on ports) = 100 bar / 1450 psi
0.1 0.2 (in)

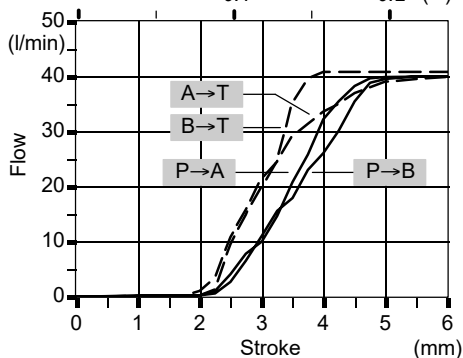

Pressure drop in position 3

(last section)

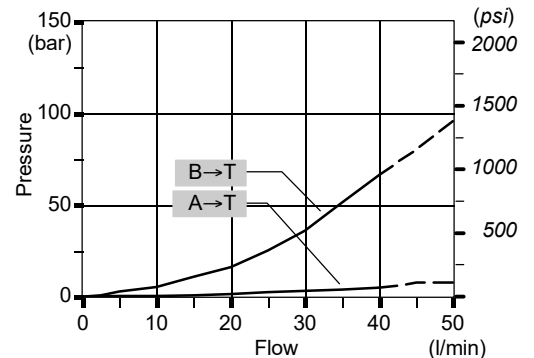

Working section type E19.

8EB3 proportional electro-hydraulic control

With spring return to neutral position.

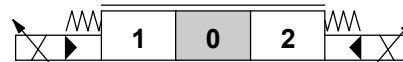
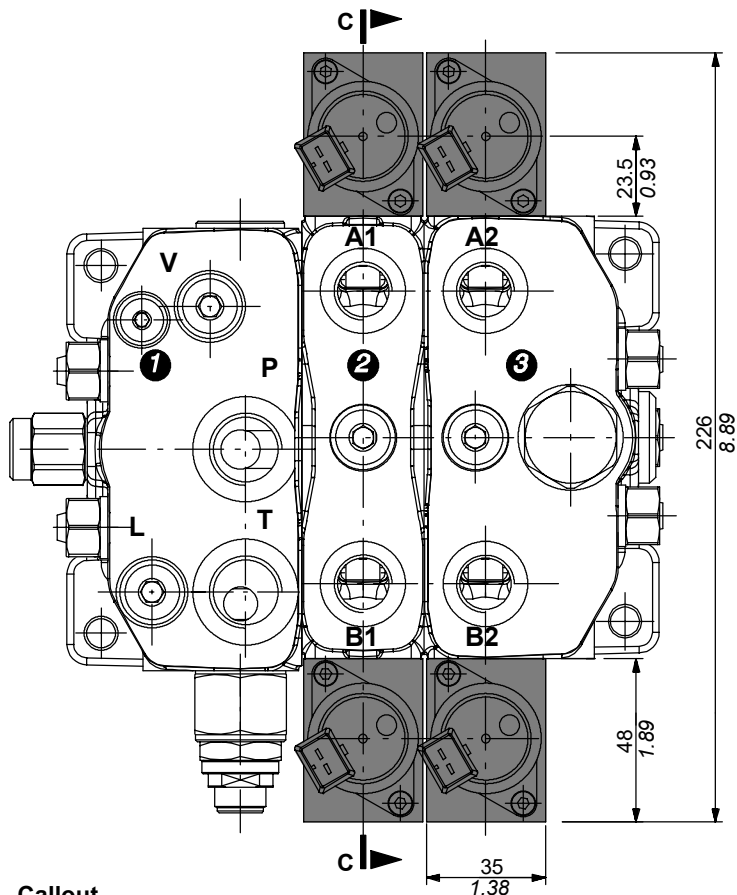

Operating features

SOLENOID VALVE

Pilot max. pressure	: 315 bar - 4600 psi
Min. feeding pressure	: 40 bar - 580 psi
Max. backpressure on drain	: 20 bar - 290 psi
Max. internal leakage	: 3 cm ³ /min - 0.18 in ³ /min
Max. hysteresis	: 13%
Nominal voltage	: 12 24 VDC ± 10%
Coil resistance (20 °C)	: 5.3 24 Ω
Nominal current	: 1.5 0.63 A
Duty cycle	: 100%
Operating frequency	: 125 Hz
Weather protection	: IP65

Current - stroke diagram

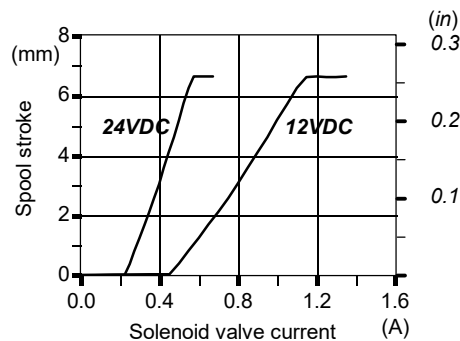

Callout

- 1) CRV type inlet cover with pressure-reducing valve (VRP), relief valve (VLP), internal pilot and drain
- 2) Working section (PE, QE...) with pilot lines
- 3) Optional outlet working section (RPE, RQE) with pilot lines and backpressure valve (VRC or VRE)

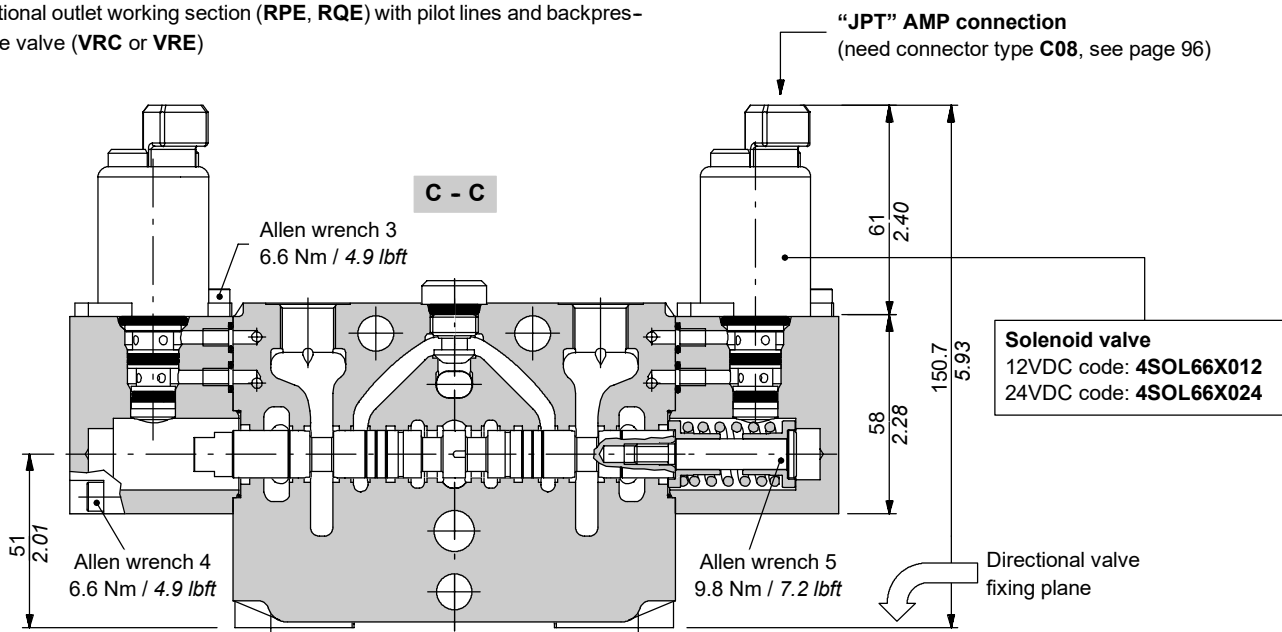

8EB3LH proportional electro-hydraulic control

With spring return to neutral position and wet-type lever box.

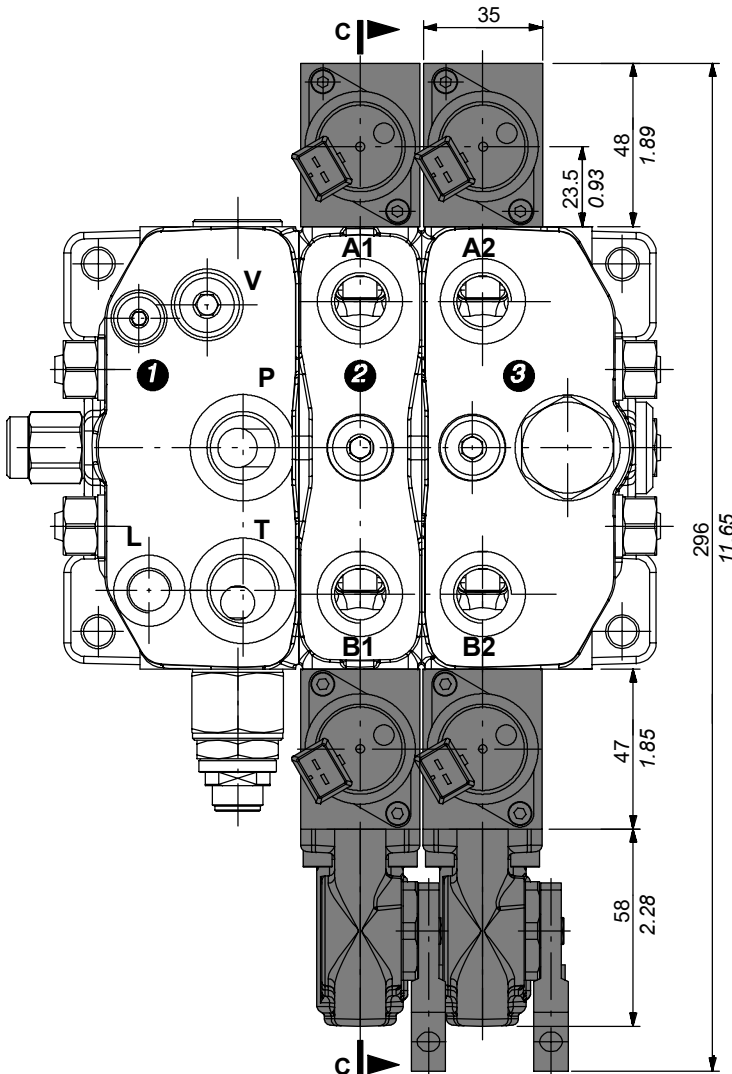
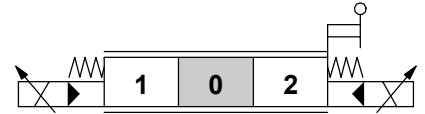

Operating features

SOLENOID VALVE

Pilot max. pressure	: 315 bar - 4600 psi
Min. feeding pressure	: 40 bar - 580 psi
Max. backpressure on drain	: 20 bar - 290 psi
Max. internal leakage	: 3 cm ³ /min - 0.18 in ³ /min
Max. hysteresis	: 13%
Nominal voltage	: 12 24 VDC ± 10%
Coil resistance (20 °C)	: 5.3 24 Ω
Nominal current	: 1.5 0.63 A
Duty cycle	: 100%
Operating frequency	: 125 Hz
Weather protection	: IP65

Current - stroke diagram

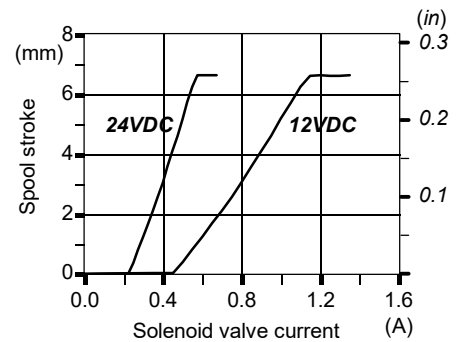

Callout

- 1) CRV type inlet cover with pressure-reducing valve (VRP), relief valve (VLP), internal pilot and external drain (suggested)
- 2) Working section (PE, QE....) with pilot lines
- 3) Optional outlet working section (RPE, RQE) with pilot lines and backpressure valve (VRC or VRE)

21.Working section type E

8EB3LH proportional electro-hydraulic control

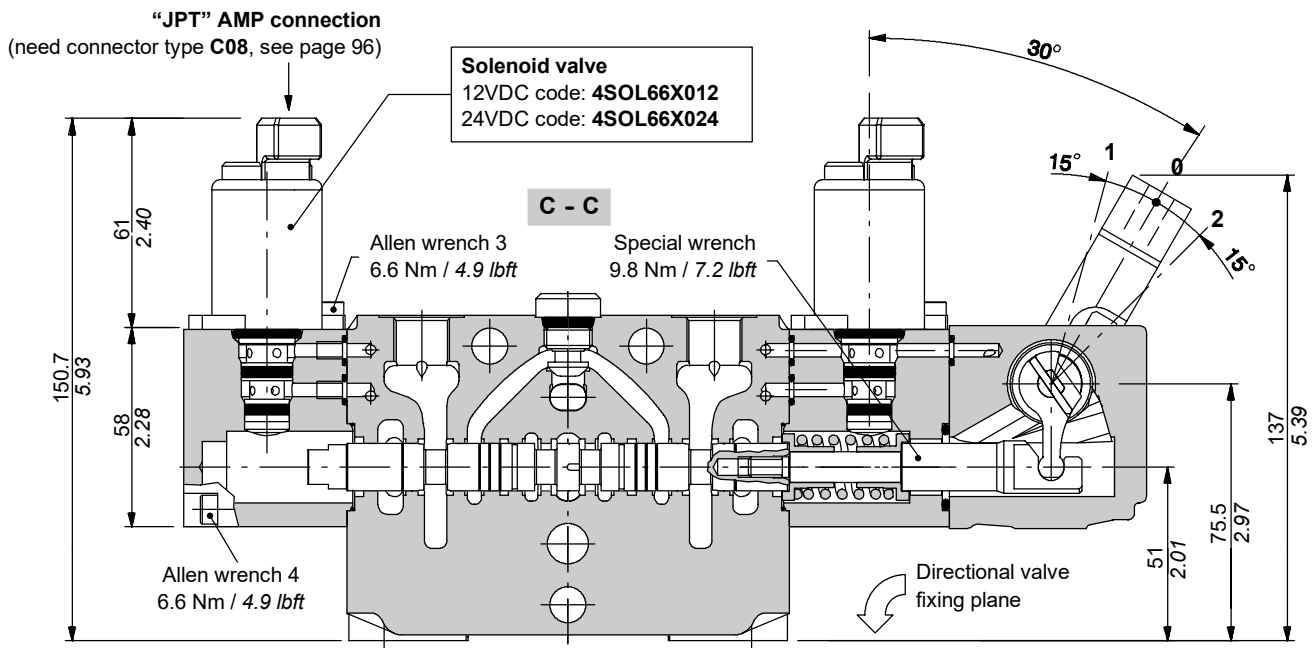

Lever-holder configuration

The control is supplied with lever-holder in standard configuration; different position must always specified (8EB3LH1 and 8EB3LH2).

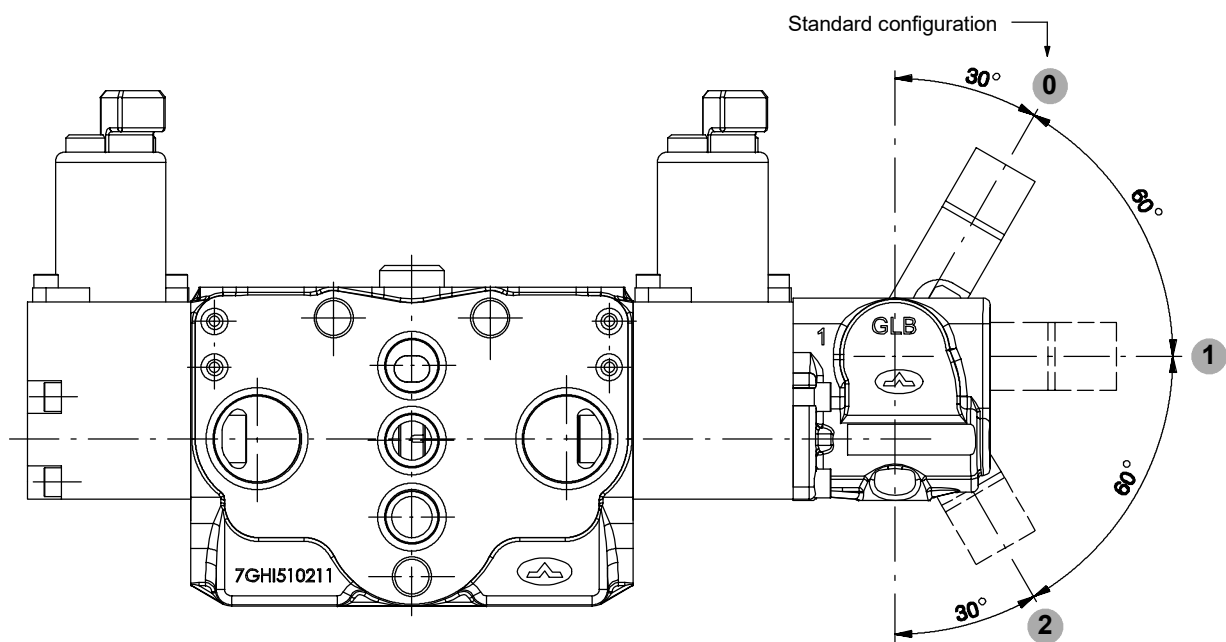

13EB3 proportional electro-hydraulic control

With spring return to neutral position: available for spool type E501 (see page 77).

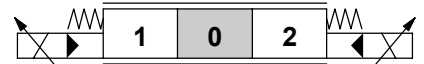
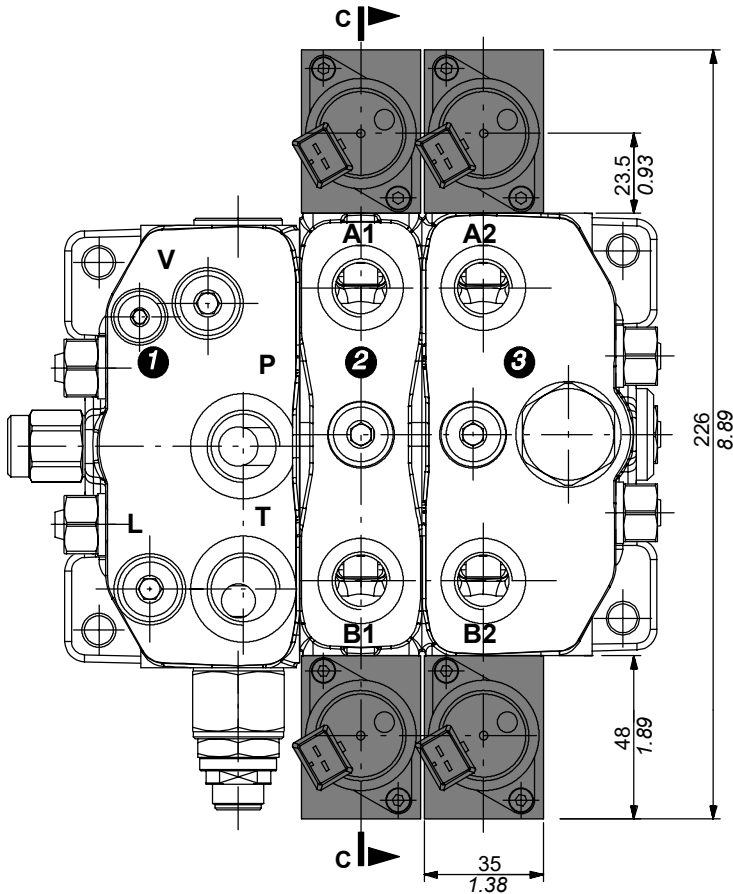

Operating features

SOLENOID VALVES

Pilot max. pressure	: 315 bar - 4600 psi
Min. feeding pressure	: 40 bar - 580 psi
Max. backpressure on drain	: 20 bar - 290 psi
Max. internal leakage	: 3 cm ³ /min - 0.18 in ³ /min
Max. hysteresis	: 13%
Nominal voltage	: 12 24 VDC ± 10%
Coil resistance (20 °C)	: 5.3 24 Ω
Nominal current	: 1.5 0.63 A
Duty cycle	: 100%
Operating frequency	: 125 Hz
Weather protection	: IP65

Current - stroke diagram

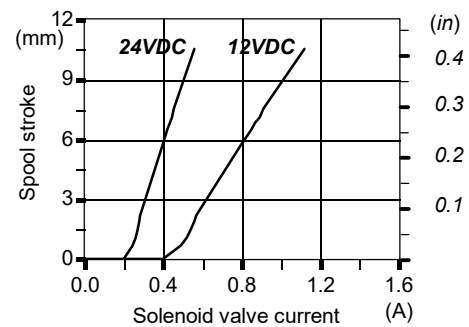

Callout

- 1) CRV type inlet cover with pressure-reducing valve (VRP), relief valve (VLP), internal pilot and drain
- 2) Working section (PE, QE....) with pilot lines
- 3) Optional outlet working section (RPE, RQE) with pilot lines and backpressure valve VRC(21)

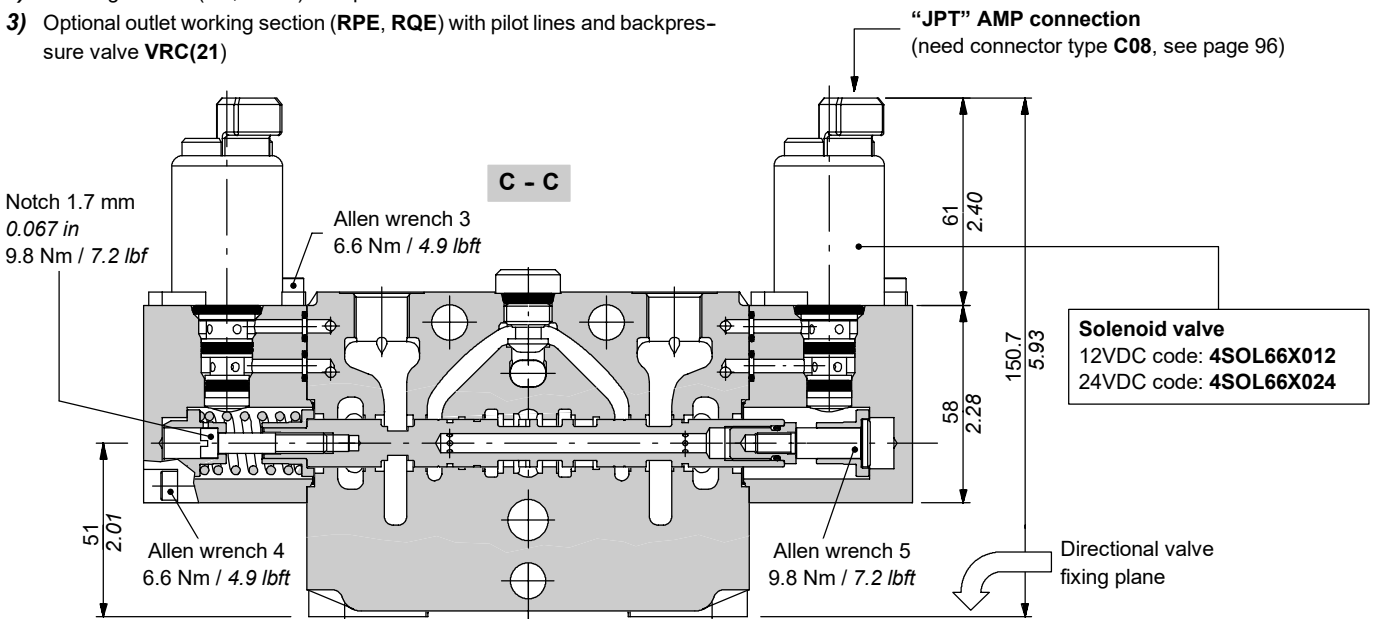

Working section type E20.

13EB3LH proportional electro-hydraulic control

With spring return to neutral position and wet-type lever box: available for spool type E501 (see page 77).

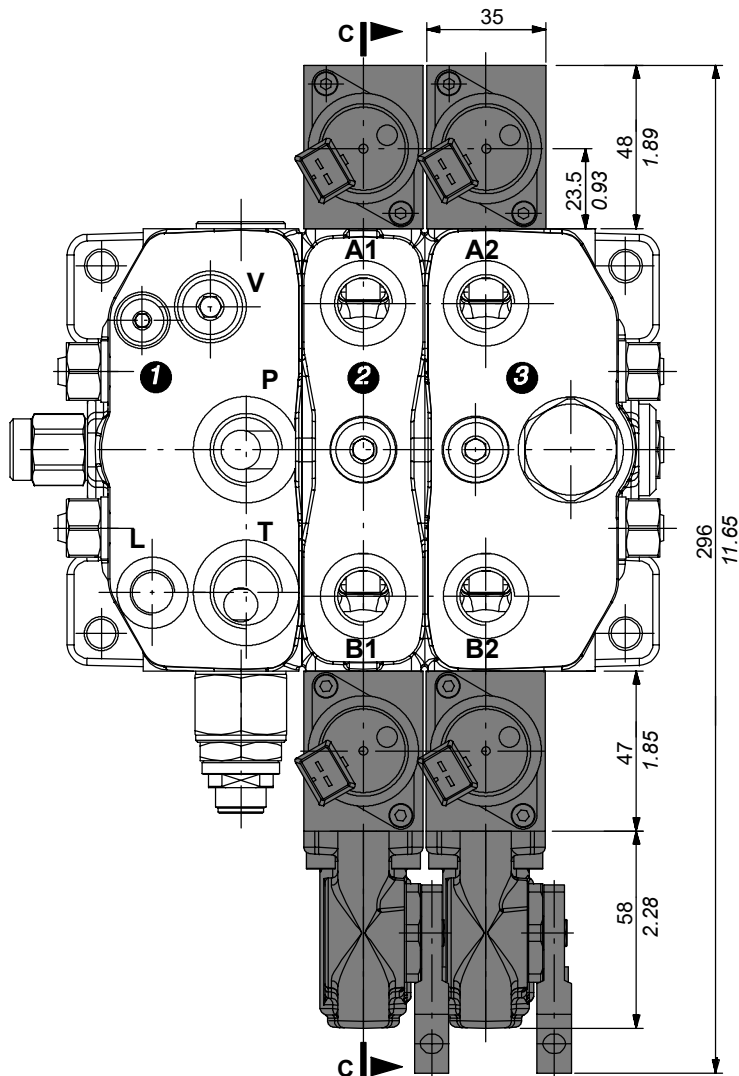
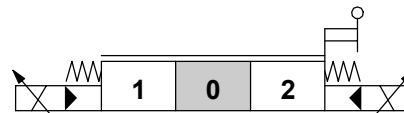

Operating features

SOLENOID VALVE

- Pilot max. pressure : 315 bar - 4600 psi
- Min. feeding pressure : 40 bar - 580 psi
- Max. backpressure on drain : 20 bar - 290 psi
- Max. internal leakage : 3 cm³/min - 0.18 in³/min
- Max. hysteresis : 13%
- Nominal voltage : 12 24 VDC ± 10%
- Coil resistance (20 °C) : 5.3 24 Ω
- Nominal current : 1.5 0.63 A
- Duty cycle : 100%
- Operating frequency : 125 Hz
- Weather protection : IP65

Current - stroke diagram

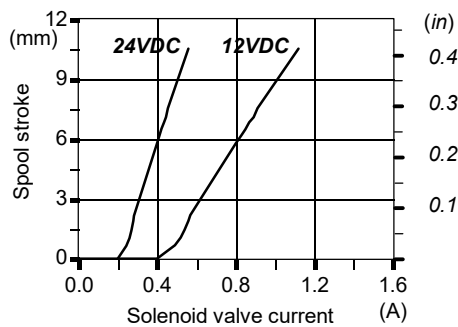

Callout

- 1) CRV type inlet cover with pressure-reducing valve (VRP), relief valve (VLP), internal pilot and external drain (suggested)
- 2) Working section (PE, QE....) with pilot lines
- 3) Optional outlet working section (RPE, RQE) with pilot lines and backpressure valve VRC(21)

8EB3LH proportional electro-hydraulic control

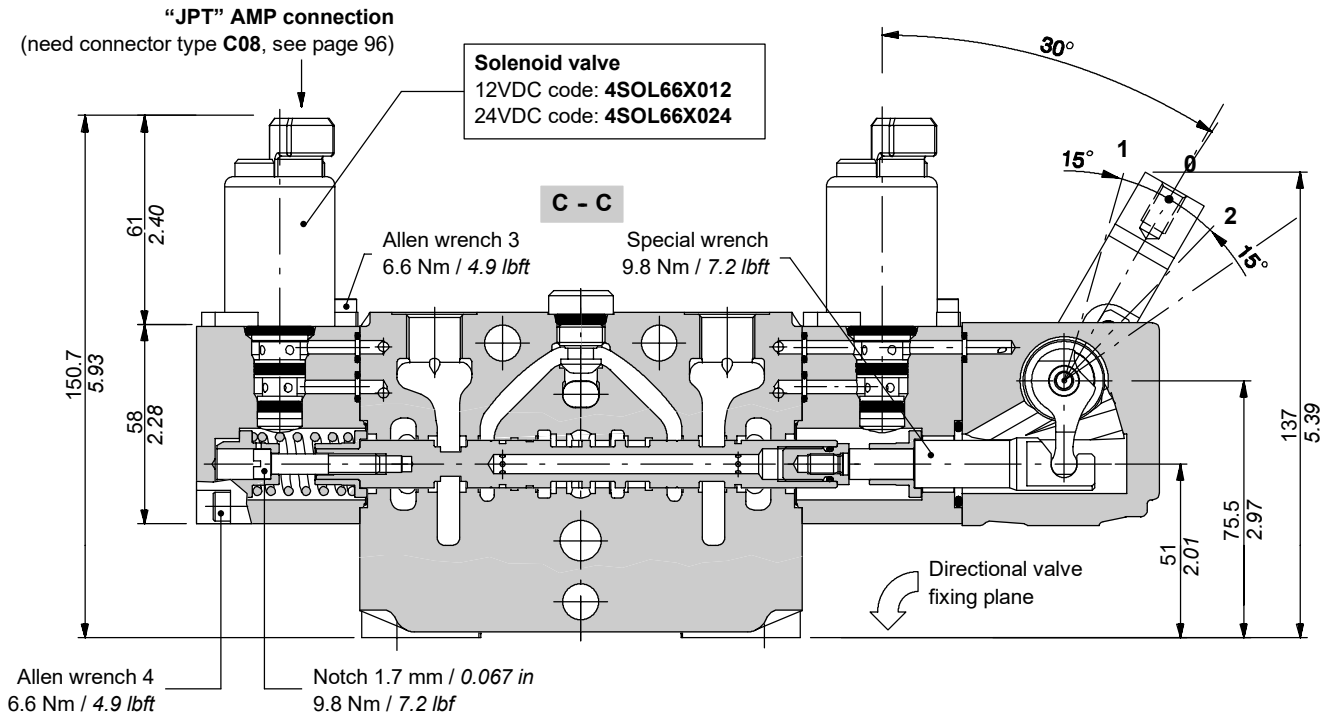

Lever-holder configuration

The control is supplied with lever-holder in standard configuration; different position must always specified (13EB3LH1 and 13EB3LH2).

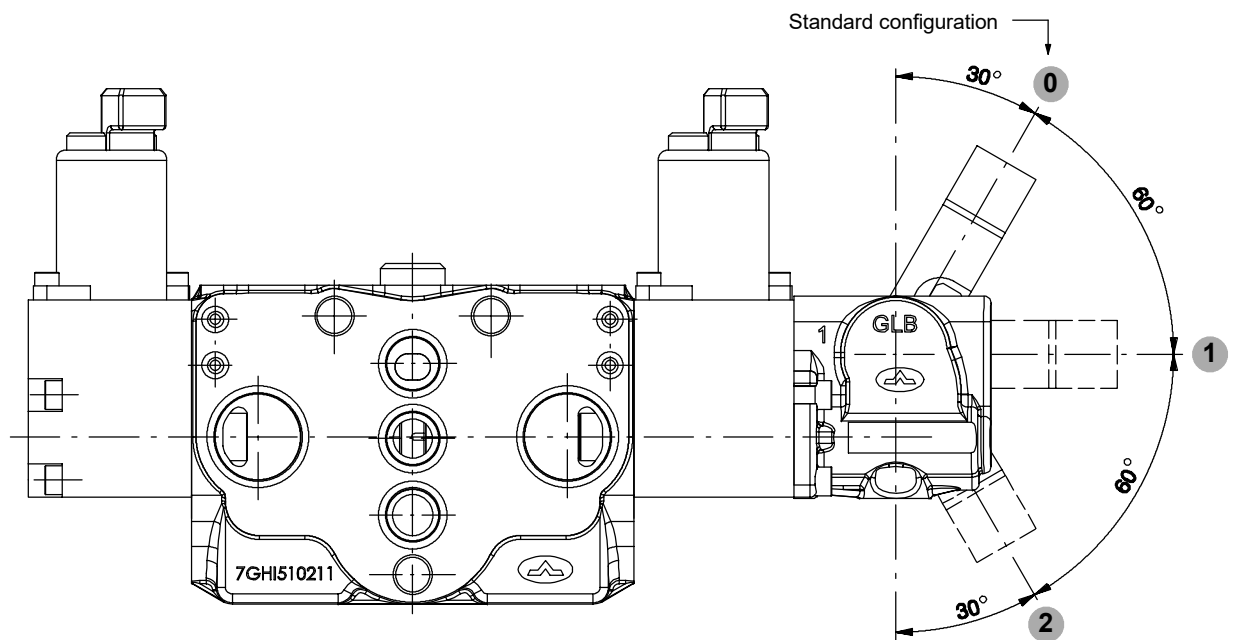

Section with optional outlet type RE

Valve description:

EL SDS100 / RPE - E101 - 8EB3 . U100U100 - VRC - F - 12VDC *

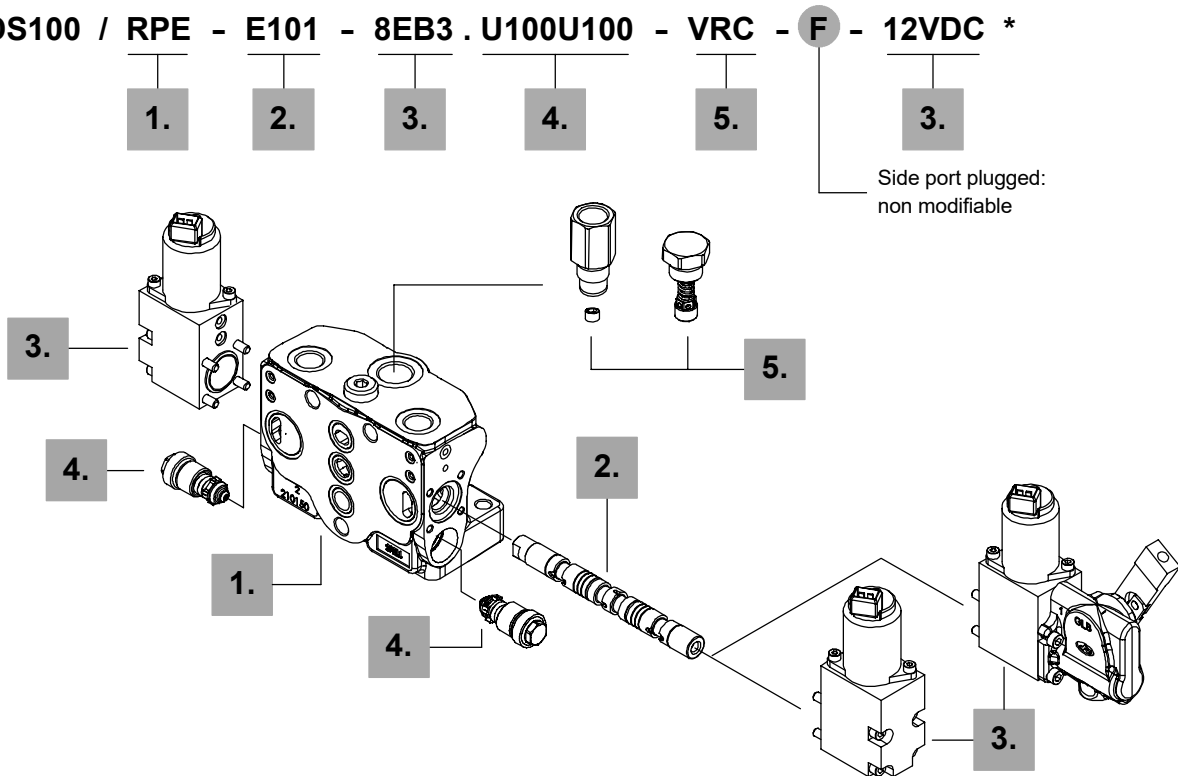

1. Working section kit * page 85

Include body, seals and load check valve.

TYPE	CODE	DESCRIPTION
RQE	5FIA207312	Parallel circuit without port valves prearrangement
RPE	5FIA207302	Parallel circuit with port valves prearrangement

2. Spools page 74

If not specified otherwise, the spool are from 20 to 40 l/min flow

TYPE	CODE	DESCRIPTION
E102	3CU6710102	Double acting, 3 positions, with A and B closed in neutral position; for flow up to 20 l/min
E101	3CU6710000	As previous, from 20 to 40 l/min flow
E103	3CU6710103	As previous, from 40 to 60 l/min flow
E201	3CU6725000	Double acting, 3 positions, with A and B open to tank in neutral position
E301	3CU6731000	Single acting in A, 3 positions, B plugged: needs G3/8 plug

Specials spools for particular positioners kit pag. 77

E501	3CU6752501	Double acting, 4 positions, floating in 4 th positions with spool in
-------------	------------	---

NOTE (*) - Codes are referred to **BSP** thread.

3. Electro-hydraulic controls page 78

TTYPE	CODE	DESCRIPTION
8EB3	5IDR907312	12VDC double side proportional type with spring return to neutral position
	5IDR907324	As previous 24VDC
8EB3LH	5IDR907612	12VDC double side proportional type with spring return to neutral position and wet-type lever control
	5IDR907624	As previous 24VDC

Particular positioners kit for special spools page 78

TYPE	CODE	DESCRIPTION
13EB3	5IDR917312	AS type 8EB3, 12VDC: for spool type E501
	5IDR917324	As previous 24VDC
13EB3LH	5IDR917712	AS type 8EB3LH, 12VDC: for spool type E501
	5IDR917724	As previous 24VDC

4. Port valves page 54

Fixed setting antishock with prefill valves.

5. Circuit options * page 87

TYPE	CODE	DESCRIPTION
VRC	5GIU511370	Backpressure valve for 8EB3 and 8EB3LH controls
VRC(21)	5GIU511371	Backpressure valve for 13EB3 and 13EB3LH controls
VRE	5GIU527590	Backpressure valve and carry-over: include M14x1.5 plug. Only for 8EB3 and 8EB3LH controls

Section with optional outlet type RE

Section kit and hydraulic circuit

Configuration combining a working section with the closing flange to reduce dimensions.

Below it's show a configuration with parallel circuit, backpressure valve, optional side outlet port plugged (F type).

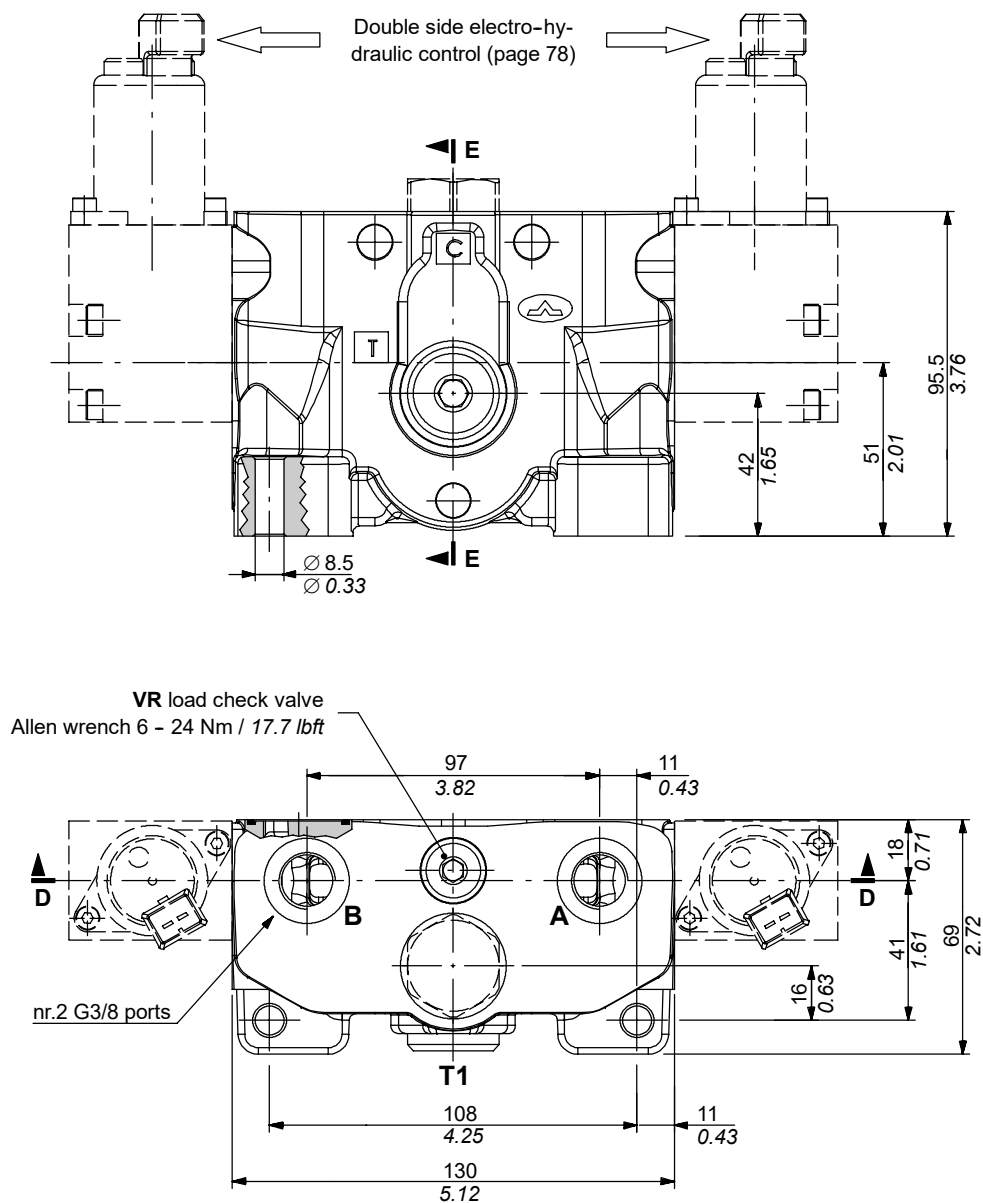

Section with optional outlet type RE

Section kit and hydraulic circuit

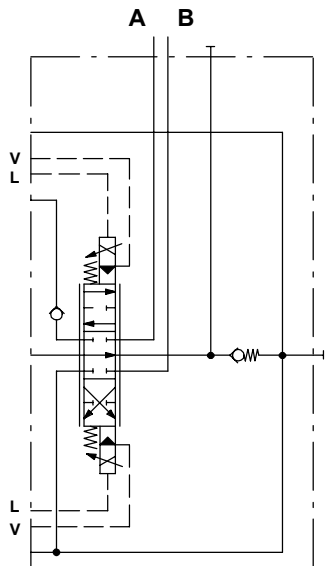
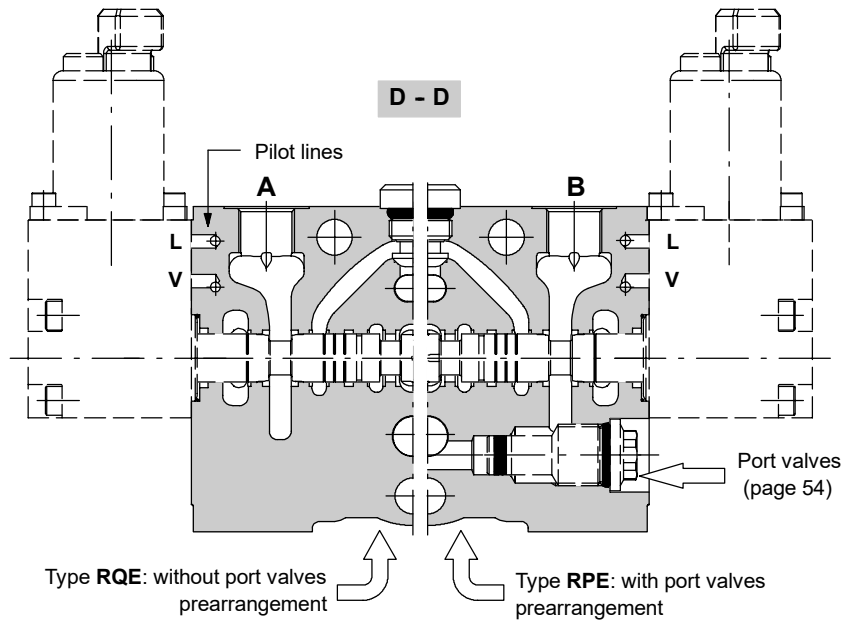

Description example:
RQE-E101-8EB3-VRC-F-12VDC

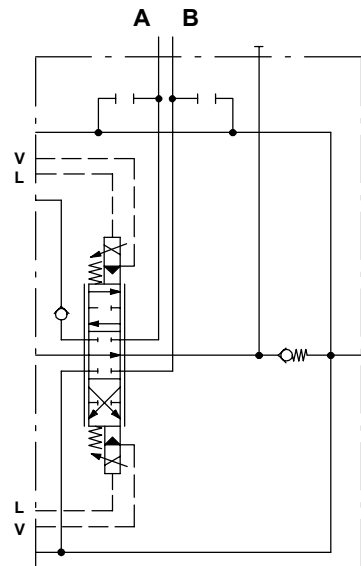

Description example:
RPE-E101-8EB3.UTUT-VRC-F-12VDC

Circuit options

With VRC backpressure valve

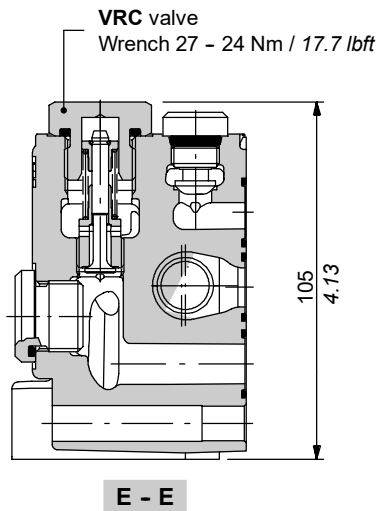

VRC performace diagram

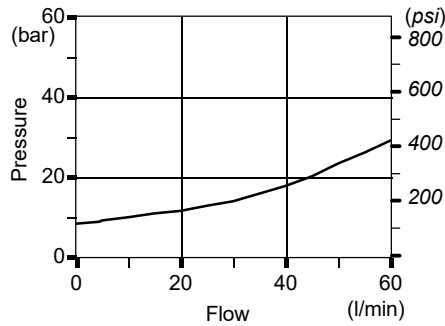

VRC(21) performace diagram

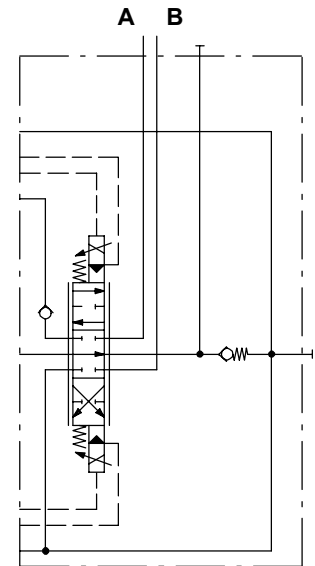
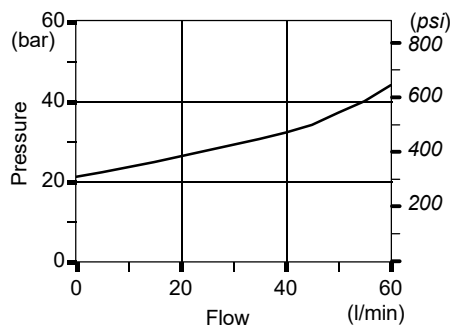

Description example:
RQE-E101-8EB3-VRC-F-12VDC

With VRE backpressure valve (carry-over)

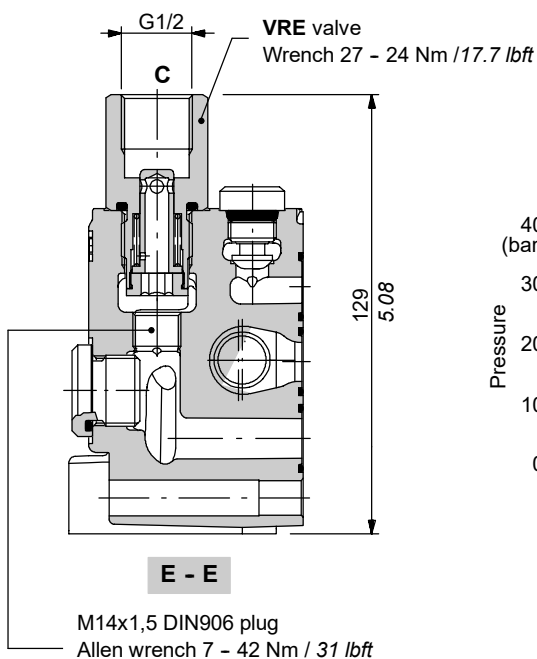

Performace diagram

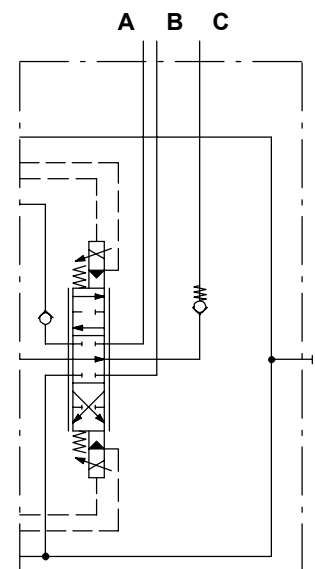
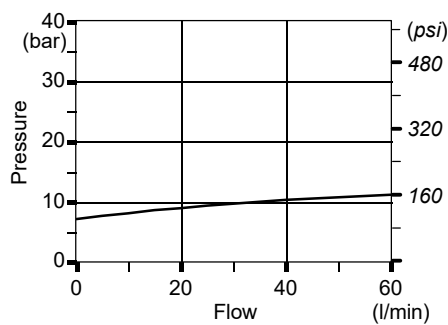

Description example:
RQE-E101-8EB3-VRE-F-12VDC

Working section type A

Description example:

EL SDS100 / PA - 101 - 8 L . U100 U100 *

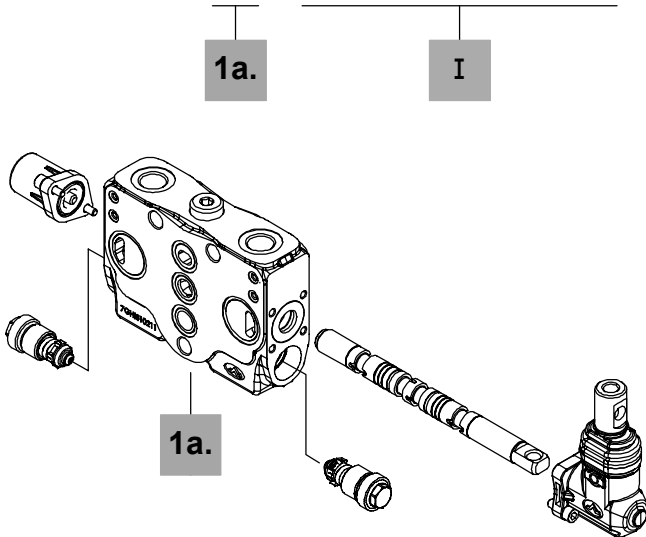

EL SDS100 / QA - I112 - 8IM

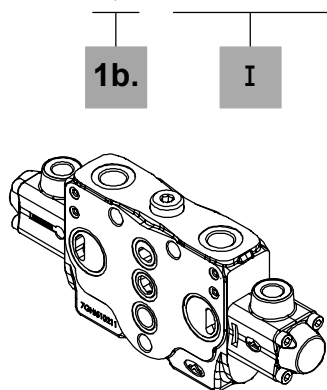

EL SDS100 / QA - S112 - 8ES3 - 12VDC

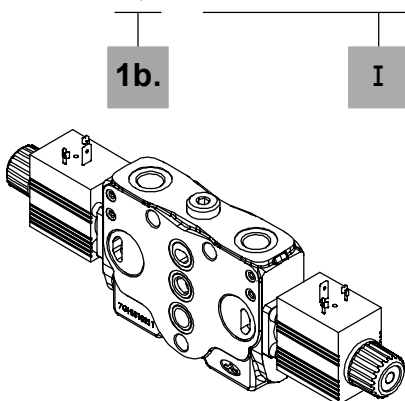

NOTE (*) - Codes are referred to **BSP** thread.

1a. Working section kit * page 89

For mechanical controls.

Include body, seals, rings and load check valve.

TYPE	CODE	DESCRIPTION
QA	5EL1073013	Parallel circuit without port valves prearrangement
PA	5EL1073003	Parallel circuit with port valves prearrangement
SQA	5EL3073013	Tandem circuit without port valves prearrangement
SPA	5EL3073003	Tandem circuit with port valves prearrangement

1b. Working section kit *

For proportional hydraulic and ON/OFF solenoid controls.

Include body, seals and load check valve.

TYPE	CODE	DESCRIPTION
QA/IM-ES	5EL1073013A	Parallel circuit without port valves prearrangement
PA/IM-ES	5EL1073003A	Parallel circuit with port valves prearrangement
SQA/IM-ES	5EL3073013A	Tandem circuit without port valves prearrangement
SPA/IM-ES	5EL3073003A	Tandem circuit with port valves prearrangement

I Other options page 21

For complete list of spools, controls and port valves see page 21: available options are the same of directional valve with standard working section.

Section kit and hydraulic circuit

Sections with pilot lines for manual/mechanical control in electro-hydraulic valves.
Dimensions are the same as other sections.

Parallel circuit

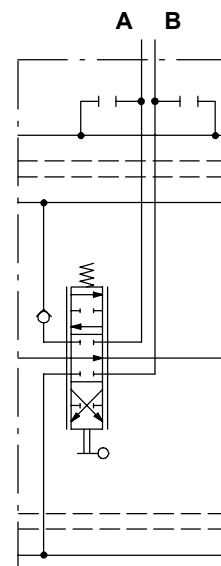
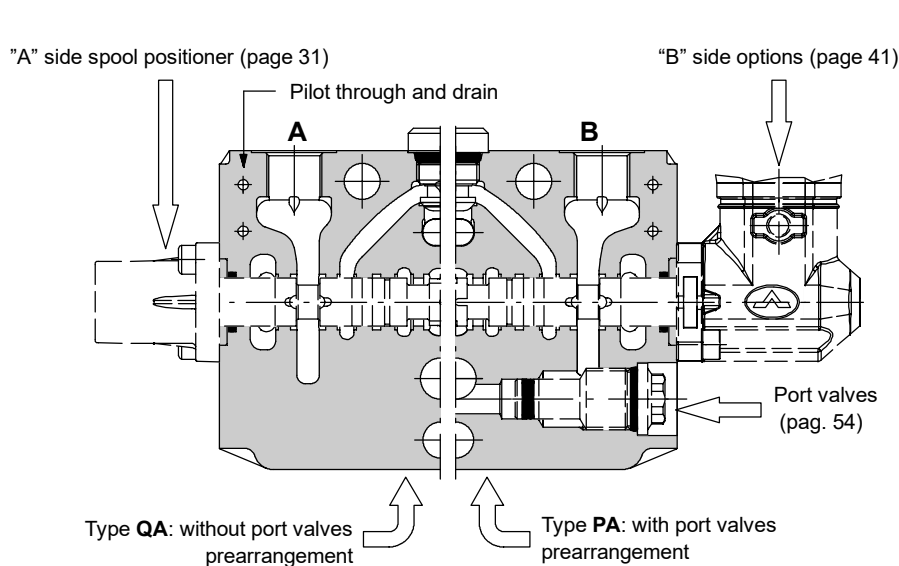

Description example:
PA-101-8L.UTUT

Tandem circuit

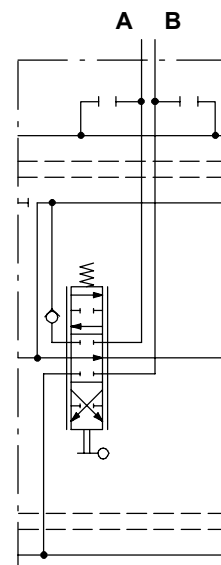
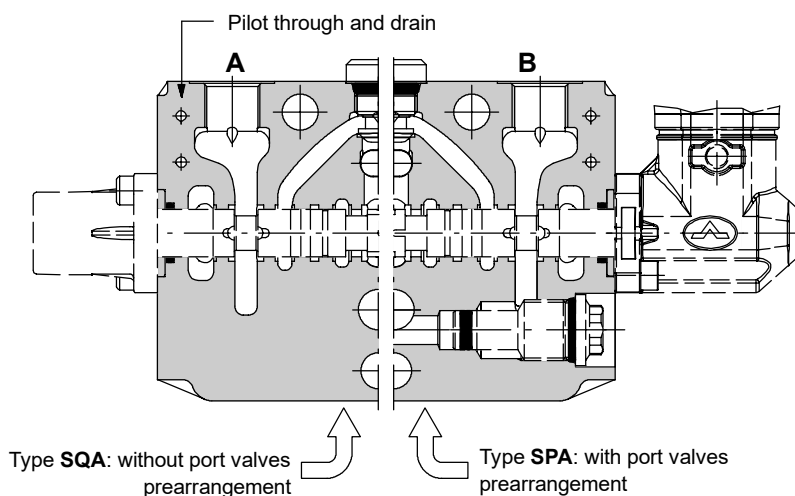

Description example:
SPA-101-8L.UTUT

Section with optional outlet type RA

Description example:

EL SDS100 / RPA - 101 - 8L . U100U100 - VRC - F *

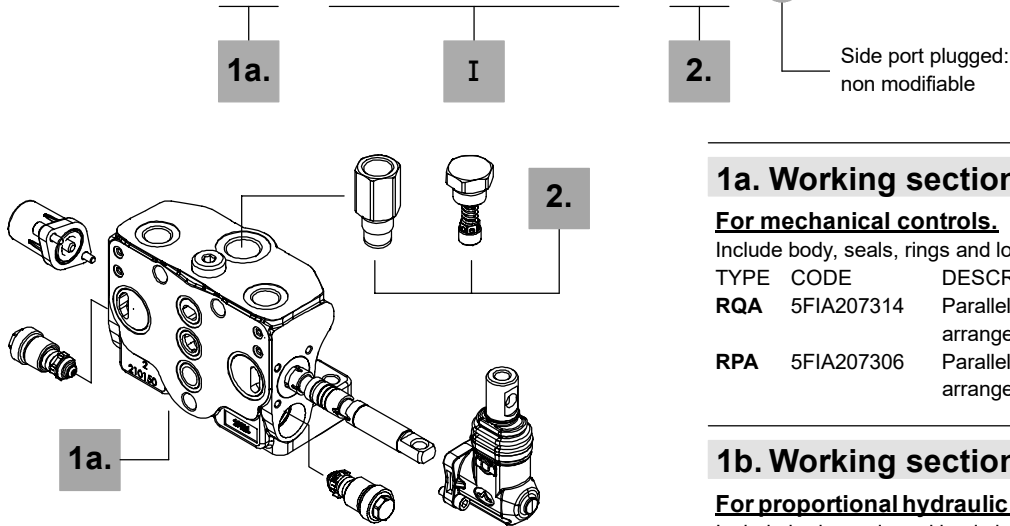

1a. Working section kit * page 91

For mechanical controls.

Include body, seals, rings and load check valve.

TYPE	CODE	DESCRIPTION
RQA	5FIA207314	Parallel circuit without port valves arrangement
RPA	5FIA207306	Parallel circuit with port valves arrangement

1b. Working section kit *

For proportional hydraulic and ON/OFF solenoid controls.

Include body, seals and load check valve.

TYPE	CODE	DESCRIPTION
RQA/IM-ES	5FIA207316A	Parallel circuit without port valves arrangement
RPA/IM-ES	5FIA207306A	Parallel circuit with port valves arrangement

EL SDS100 / RQA - I112 - 8IM - VRC - F *

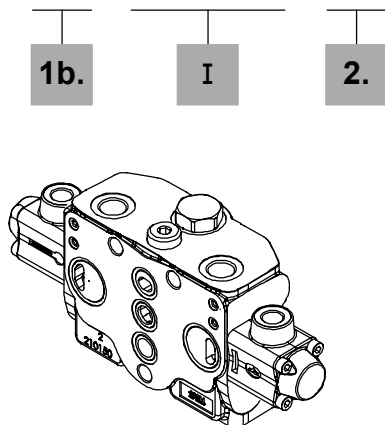

2. Circuit options * page 87

TYPE	CODE	DESCRIPTION
VRC	5GIU511370	Backpressure valve for 8EB3 and 8EB3LH prop. electrohydraulic controls
VRC(21)	5GIU511371	Backpressure valve for 13EB3 and 13EB3LH prop. electrohydraulic controls
VRE	5GIU527590	Backpressure valve and carry-over: include M14x1.5 plug. Only for 8EB3 and 8EB3LH prop. electrohydraulic controls

I Other options page 21

For complete list of spools, controls and port valves see page 21: available options are the same of directional valve with standard working section.

EL SDS100 / RQA - S112 - 8ES3 - VRC - F - 12VDC *

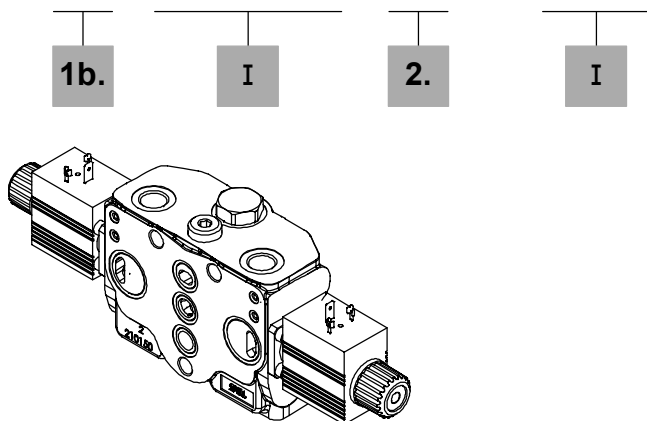

NOTE (*) - Codes are referred to **BSP** thread.

Section with optional outlet type RA

Section kit and hydraulic circuit

For dimensions and characteristics see section type RE at page 85.

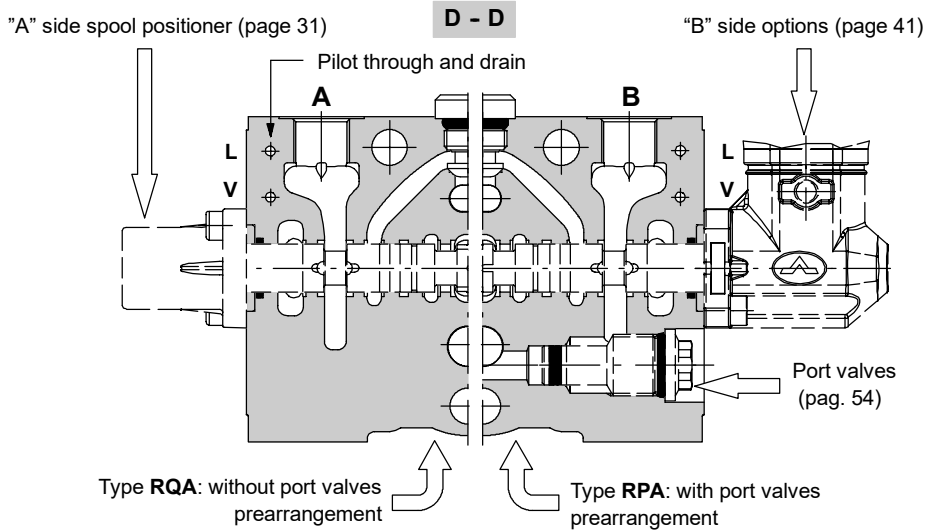

Type RQA: without port valves prearrangement

Type RPA: with port valves prearrangement

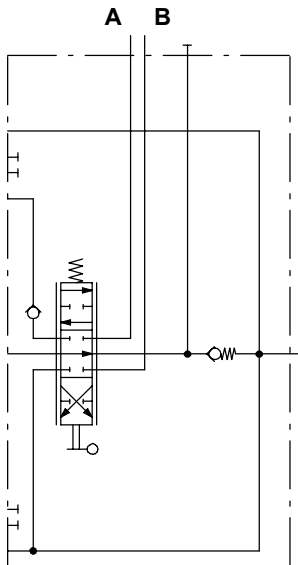

Description example:
RQA-101-8L-VRC-F

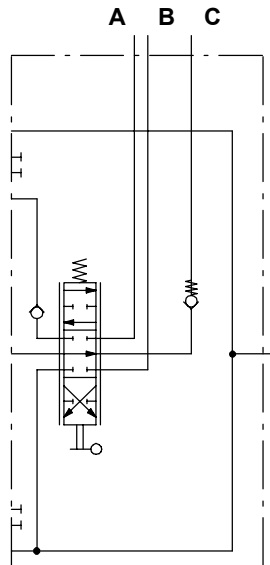

Description example:
RQA-101-8L-VRE-F

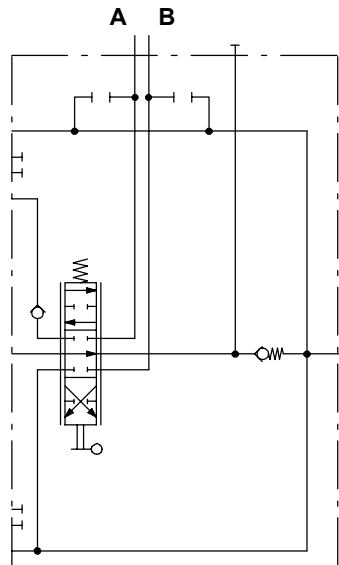

Description example:
RPA-101-8L.UTUT-VRC-F

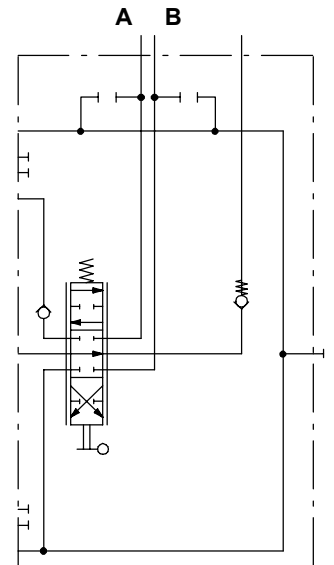

Description example:
RPA-101-8L.UTUT-VRE-F

The SDS100 valve is assembled and tested as per the technical specification of this catalogue.

Before the final installation on your equipment, follow the below recommendations:

- the valve can be assembled in any position, in order to prevent body deformation and spool sticking mount the product on a flat surface;
- in order to prevent the possibility of water entering the lever box and spool control kit, do not use high pressure wash down directly on the valve;
- prior to painting, ensure plastic port plugs are tightly in place.

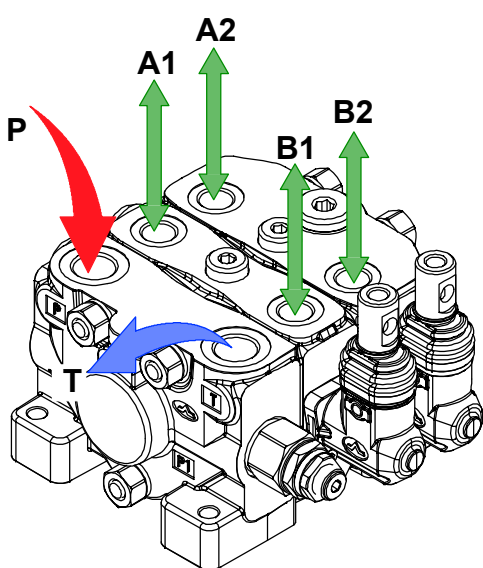

SDS100/2/CN(TVG3-175)/Q-101-8L/RQ-101-8L-F

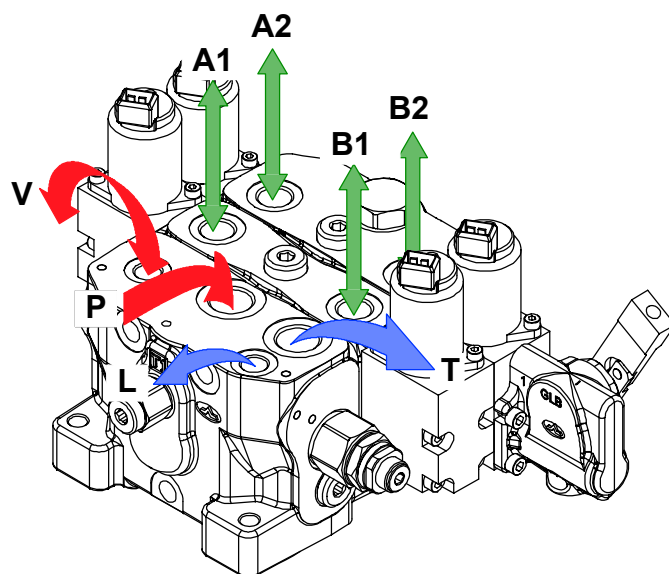

SDS100/2/CRV(TVG3-175)/
QE-E101-8EB3/RQE-E101-8EB3LH-VRC-F-12VDC

Fitting tightening torque - Nm / lbft

THREADS TYPE	P and C ports	A and B ports	T port	V and L ports
BSP	G 1/2	G 3/8	G 1/2	G 1/4
With O-Ring seal	50 / 36.9	35 / 25.8	50 / 36.9	20 / 14.7
With copper washer	60 / 44.3	40 / 29.5	60 / 44.3	25 / 18.4
With steel and rubber washer	60 / 44.3	30 / 22.1	60 / 44.3	16 / 11.8
UN-UNF	7/8-14 (SAE 10)	3/4-16 (SAE 8)	7/8-14 (SAE 10)	9/16-18 (SAE 6)
With O-Ring seal	90 / 66.4	35 / 25.8	90 / 66.4	30 / 22.1

NOTE - These torque are recommended. Assembly tightening torque depends on many factors, including lubrication, coating and surface finish. The manufacturer shall be consulted.

Installation and maintenance

Mechanical control configuration.

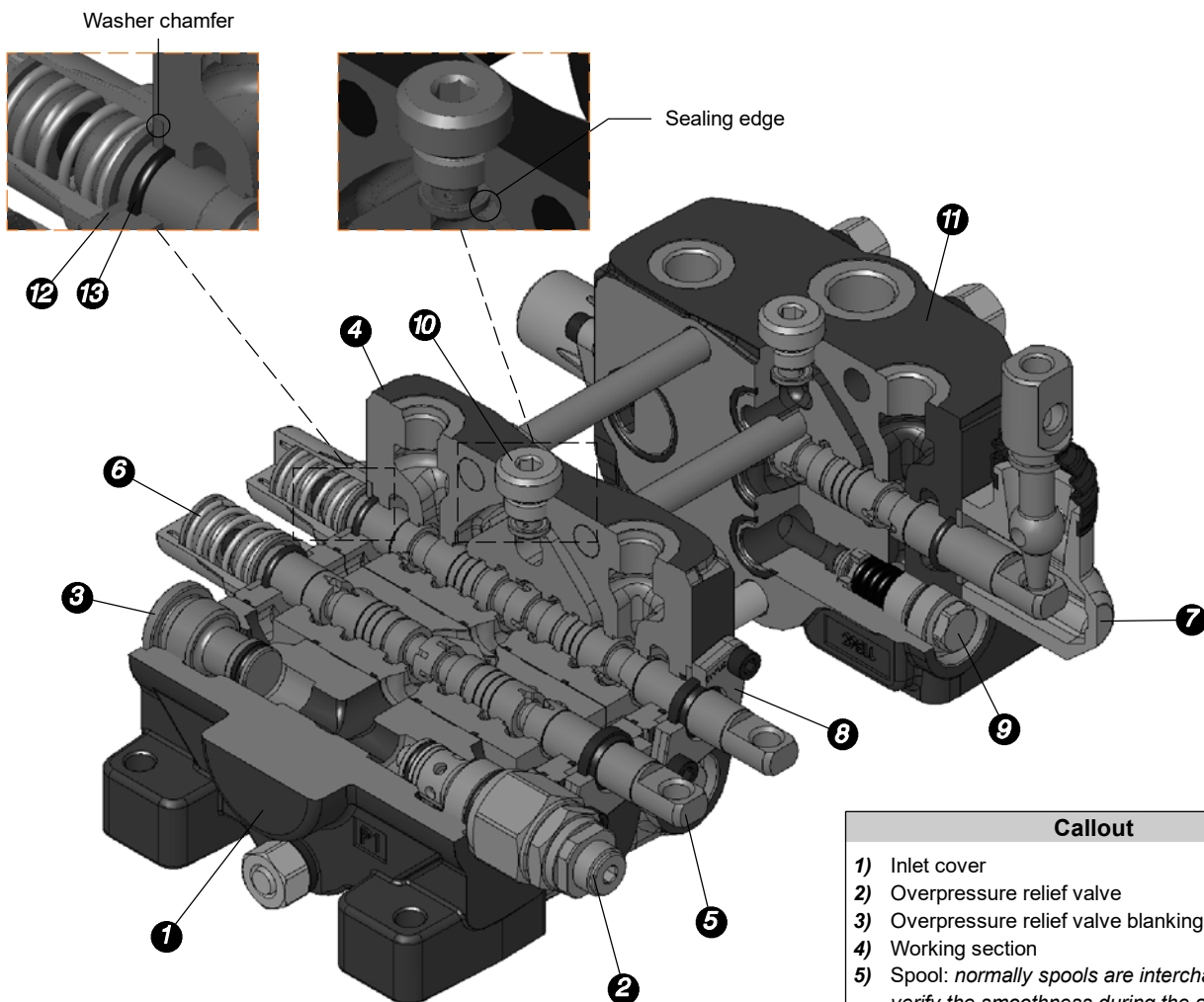

Callout	
1)	Inlet cover
2)	Overpressure relief valve
3)	Overpressure relief valve blanking plug
4)	Working section
5)	Spool: <i>normally spools are interchangeable, verify the smoothness during the assembly</i>
6)	"A" side spool positioner
7)	Lever pivot box
8)	Dust-proof flange
9)	Port valves
10)	Load check valve
11)	Working section with optional outlet
12)	Holding O-Ring washer code: 3ANE126020
13)	O-Ring seal 14.00x2 code: 4GUA114020

NOTE - All moving parts inside cap, lever box and mechanical joystick are lubricated with synthetic base grease grade NLGI2

Malfunction	Cause	Remedy
External leakage pivot box lever or control kit side.	Worn spool seal due to mechanical actuation.	Locate the leakage and replace the seal.
Excessive internal leakage on A and B ports.	Increase clearance between spools and body due to high wear.	Replace the working section and check the oil contamination level.
Dropping load during transition while raising.	High leakage on the load check valve.	Remove the load check valve and clean the seat, verifying it's not dented.
Inability to build pressure on A and B ports.	Pressure relief valve blocked open. Low pump pressure and flow.	Remove and clean or replace the valve. Check the pump and circuit.

Electrohydraulic proportional control configuration.

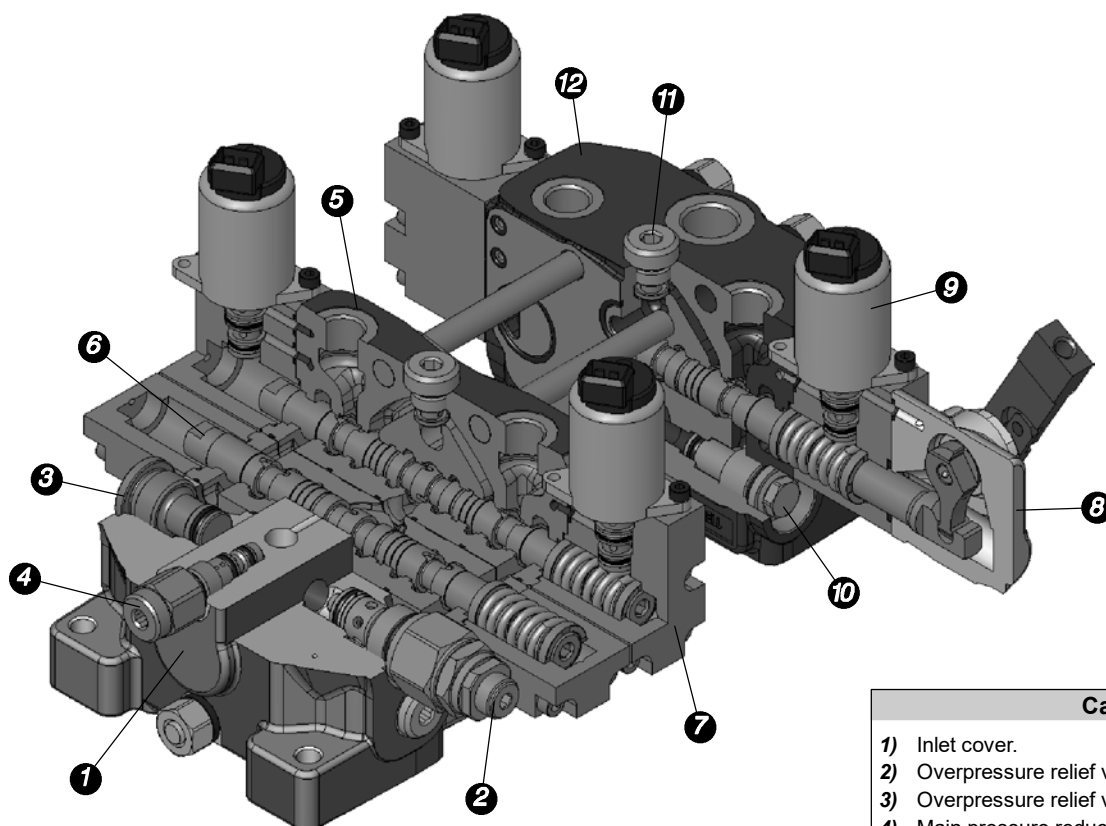

Callout	
1)	Inlet cover.
2)	Overpressure relief valve.
3)	Overpressure relief valve blanking plug.
4)	Main pressure reducing valve.
5)	Working section type E.
6)	Spool: <i>normally spools are interchangeable, verify the smoothness during the assembly.</i>
7)	8EB3 spool control.
8)	8EB3LH spool control.
9)	Pressure reducing valves.
10)	Port valve.
11)	Load check valve.
12)	Working section with optional outlet type RE, with backpressure valve.

Malfunction	Cause	Remedy
External leakage pivot box lever or control kit side.	Worn spool seal due to mechanical actuation or high back pressure.	Sostituire le guarnizioni usurate.
Excessive internal leakage on A and B ports.	Increase clearance between spools and body due to high wear.	Replace the working section and check the oil contamination level.
Dropping load during transition while raising.	High leakage on the load check valve.	Remove the load check valve and clean the seat, verifying it's not dented.
Inability to build pressure on A and B ports.	Pressure relief valve blocked open.	Remove and clean or replace the valve.
	Low pump pressure and flow.	Check the pump and circuit.
	Current absence to pressure reducing solenoid valves.	Check the electric circuit.
	Low pilot circuit pressure.	Check the pilot circuit.

Connectors

Type C01 code: 2X1001020

2P+T according to EN175301-803

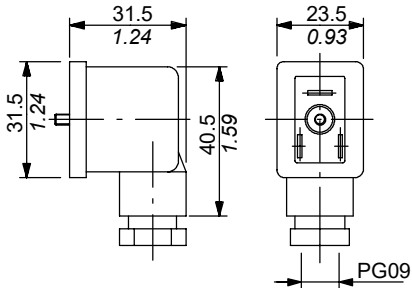

Type C02 code: 2X1001010

2P+T according to ISO4400 / EN175301-803

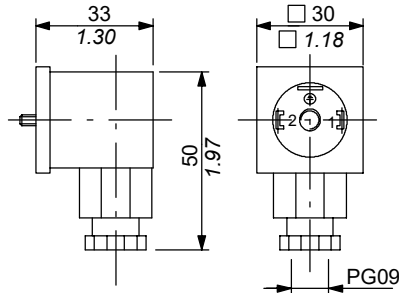

Type C03 code: 2X1001030

3P+T according to ISO4400 / EN175301-803

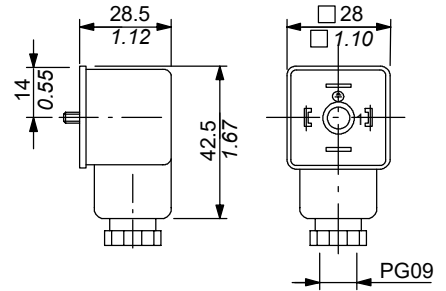

Type C07 code: 5CON001

2P male case with female end type PACKARD "Weather Pack"

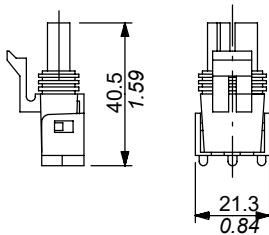

Type C08 code: 5CON003

2P female case with female end type AMP "Junior-Power-Timer"

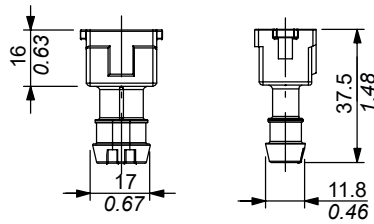

Type C17 code: 5CON005

2P female case with male end type PACKARD "Weather Pack"

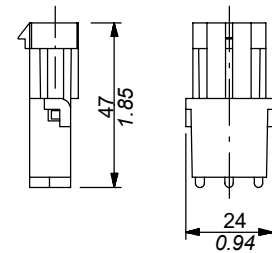

Type C19 code: 5CON007

2P male case with female end type Deutsch DT06-2S

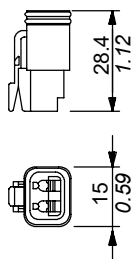

Type C20 code: 5CON017

2P male case with female end type PACKARD "Metri-Pack"

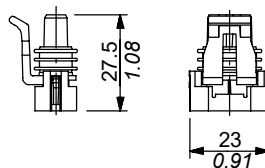

Type C21 code: 5CON018

2P female case with male end type AMP "Fastin-Faston"

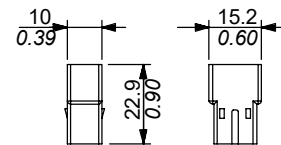

Type C24 code: 5CON0031

2P male case with female end type AMP "Superseal"

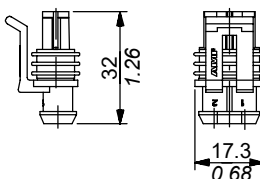

Connectors

Type	Poles	Nominal voltage	Nominal current	Permitted conductor section range	Permitted cable diameter range	Weather protection
C01	2P + T	250 VAC / 300 VDC	10 A	max.1.5 mm ² / max.0.0023 in ²	6-8 mm / 0.24-0.31 in	IP65
C02	2P + T	250 VAC / 300 VDC	10 A	max.1.5 mm ² / max.0.0023 in ²	6-8 mm / 0.24-0.31 in	IP65
C03	3P + T	250 VAC / 300 VDC	10 A	max.1.5 mm ² / max.0.0023 in ²	6 to 8 mm / 0.24 to 0.31 in	IP65
C07	2P	/	20 A	1-2 mm ² / 0.00155-0.0031 in ²	2.8-3.5 mm / 0.11-0.14 in	IP67
C08	2P	250 VAC	12 A	0.5-1 mm ² / 0.00077-0.00155 in ²	1.3-1.7 mm / 0.051-0.063in	IP65
C17	2P	/	20 A	1-2 mm ² / 0.00155-0.0031 in ²	1.4-1.6 mm / 0.055-0.067in	IP67
C19	2P	/	13 A	1-1.2 mm ² / 0.00155-0.00186 in ²	2.2-3.5 mm / 0.088-0.14 in	IP67
C20	2P	/	14 A	0.8-1 mm ² / 0.00124-0.00155 in ²	1.3-1.7 mm / 0.051-0.067in	IP65
C21	2P	/	7A	0.3-0.8 mm ² / 0.00046-0.00124 in ²	2.2-3 mm / 0.087-0.118 in	/
C24	2P	/	14A	0.3-0.5 mm ² / 0.00046-0.00077 in ²	1.4-1.7 mm / 0.055-0.067 in	IP67



WALVOIL S.P.A.

42100 REGGIO EMILIA • ITALY • VIA ADIGE, 13/D
TEL. +39.0522.932411 • FAX +39.0522.300984
E-MAIL: INFO@WALVOIL.COM • [HTTP: //WWW.WALVOIL.COM](http://WWW.WALVOIL.COM)

SALES DEPARTMENT

TEL. +39.0522.932555 • FAX +39.0522.932455

DBT001E